

### Features

- 8-Bit, 9-Bit and 10-Bit Linearity
- Low Gain and Linearity Temperature Coefficients
- Full Temperature Range Operation
- Static Discharge Input Protection
- TTL/CMOS Compatible
- Supply Range . . . . . +5V to +15V
- Fast Settling Time at 25°C . . . . . 150ns (Max)
- Four Quadrant Multiplication
- AD7533 Direct AD7520 Equivalent

### Description

The AD7523 and AD7533 are monolithic, low cost, high performance, 8-bit and 10-bit accurate, multiplying digital-to-analog converter (DAC), in a 16 pin DIP.

Intersil' thin film resistors on CMOS circuitry provide 10-bit resolution (8-bit, 9-bit and 10-bit accuracy), with TTL/CMOS compatible operation.

The AD7523 and AD7533s accurate four quadrant multiplication, full military temperature range operation, full input protection from damage due to static discharge by clamps to V+ and GND, and very low power dissipation make it a very versatile converter.

Low noise audio gain controls, motor speed controls, digitally controlled gain and digital attenuators are a few of the wide range of applications of the AD7523 and AD7533.

### Ordering Information

PART NUMBER	LINEARITY (INL, DNL)	TEMP. RANGE (°C)	PACKAGE	PKG. NO.
AD7523JN, AD7533JN	0.2% (8-Bit)	0 to 70	16 Ld PDIP	E16.3
AD7523KN, AD7533KN	0.1% (9-Bit)	0 to 70	16 Ld PDIP	E16.3
AD7523LN, AD7533LN	0.05% (10-Bit)	0 to 70	16 Ld PDIP	E16.3

### Pinout

AD7523, AD7533  
(PDIP)  
TOP VIEW

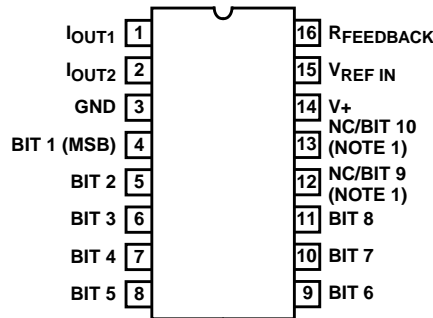

NOTE:  
1. NC for AD7523 only.

### Functional Block Diagram

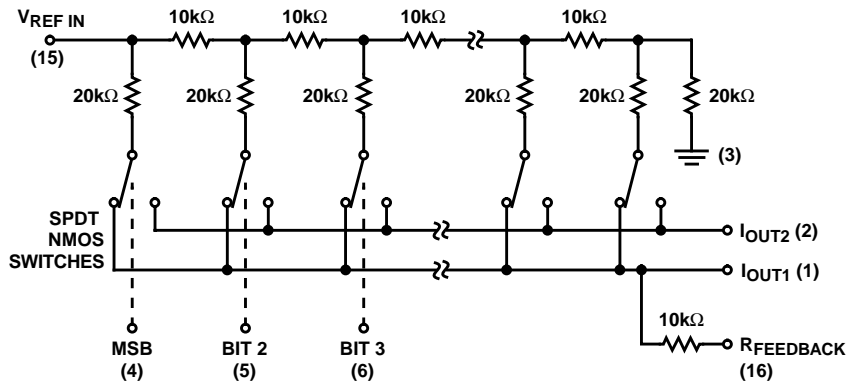

NOTE: Switches shown for digital inputs "High"

# AD7523, AD7533

## Absolute Maximum Ratings

Supply Voltage (V+ to GND) . . . . . +17V  
 V<sub>REF</sub> . . . . . ±25V  
 Digital Input Voltage Range . . . . . V+ to GND  
 Output Voltage Compliance . . . . . -100mV to V+

## Thermal Information

Thermal Resistance (Typical, Note 1) θ<sub>JA</sub> (°C/W)  
 PDIP Package . . . . . 100  
 Maximum Junction Temperature (Plastic Package) . . . . . 150°C  
 Maximum Storage Temperature . . . . . -65°C to 150°C  
 Maximum Lead Temperature (Soldering 10s) . . . . . 300°C

## Operating Conditions

Temperature Range  
 JN, KN, LN Versions . . . . . 0°C to 70°C

*CAUTION: Stresses above those listed in "Absolute Maximum Ratings" may cause permanent damage to the device. This is a stress only rating and operation of the device at these or any other conditions above those indicated in the operational sections of this specification is not implied.*

### NOTE:

- θ<sub>JA</sub> is measured with the component mounted on an evaluation PC board in free air.

## Electrical Specifications V+ = +15V, V<sub>REF</sub> = +10V, V<sub>OUT1</sub> = V<sub>OUT2</sub> = 0V, Unless Otherwise Specified

PARAMETER		TEST CONDITIONS	AD7523				AD7533				UNITS
			T <sub>A</sub> 25°C		T <sub>A</sub> MIN-MAX		T <sub>A</sub> 25°C		T <sub>A</sub> MIN-MAX		
			MIN	MAX	MIN	MAX	MIN	MAX	MIN	MAX	
<b>SYSTEM PERFORMANCE</b>											
Resolution			8	-	8	-	10	-	10	-	Bits
Nonlinearity	J	-10V ≤ V <sub>REF</sub> ≤ +10V V <sub>OUT1</sub> = V <sub>OUT2</sub> = 0V (Notes 2, 3, 6)	-	±0.2	-	±0.2	-	±0.2	-	±0.2	% of FSR
	K, T		-	±0.1	-	±0.1	-	±0.1	-	±0.1	% of FSR
	L		-	±0.05	-	±0.05	-	±0.05	-	±0.05	% of FSR
Monotonicity			Guaranteed				Guaranteed				
Gain Error		All Digital Inputs High (Note 3)	-	±1.5	-	±1.8	-	±1.4	-	±1.8	% of FSR
Nonlinearity Tempco		-10V ≤ V <sub>REF</sub> ≤ +10V (Notes 3, 4)	-	±2	-	±2	-	±2	-	±2	ppm of FSR/°C
Gain Error Tempco			-	±10	-	±10	-	±10	-	±10	ppm of FSR/°C
Output Leakage Current (Either Output)		V <sub>OUT1</sub> = V <sub>OUT2</sub> = 0	-	±50	-	±200	-	±50	-	±200	nA
<b>DYNAMIC CHARACTERISTICS</b>											
Power Supply Rejection		V+ = 14.0V to 15.0V (Note 3)	-	±0.02	-	±0.03	-	±0.005	-	±0.008	% of FSR/% of ΔV+
Output Current Settling Time		To 0.2% of FSR, R <sub>L</sub> = 100Ω (Note 4)	-	150	-	200	-	600	-	800	ns
Feedthrough Error		V <sub>REF</sub> = 20V <sub>p-p</sub> , 200kHz Sine Wave, All Digital Inputs Low (Note 4)	-	±1/2	-	±1	-	±0.05	-	±0.1	LSB
<b>REFERENCE INPUTS</b>											
Input Resistance (Pin 15)		All Digital Inputs High I <sub>OUT1</sub> at Ground (Note 4)	5	-	5	-	5	-	5	-	kΩ
			-	20	-	20	-	20	-	20	kΩ
Temperature Coefficient			-	-500	-	-500	-	-300	-	-300	ppm/°C

## AD7523, AD7533

### Electrical Specifications $V_+ = +15V$ , $V_{REF} = +10V$ , $V_{OUT1} = V_{OUT2} = 0V$ , Unless Otherwise Specified (Continued)

PARAMETER	TEST CONDITIONS	AD7523				AD7533				UNITS	
		$T_A$ 25°C		$T_A$ MIN-MAX		$T_A$ 25°C		$T_A$ MIN-MAX			
		MIN	MAX	MIN	MAX	MIN	MAX	MIN	MAX		
<b>ANALOG OUTPUT</b>											
Output Capacitance	$C_{OUT1}$	All Digital Inputs High (Note 4)	-	100	-	100	-	100	-	100	pF
	$C_{OUT2}$		-	30	-	30	-	35	-	35	pF
	$C_{OUT1}$	All Digital Inputs Low (Note 4)	-	30	-	30	-	35	-	35	pF
	$C_{OUT2}$		-	100	-	100	-	100	-	100	pF
<b>DIGITAL INPUTS</b>											
Low State Threshold, $V_{IL}$			-	0.8	-	0.8	-	0.8	-	0.8	V
High State Threshold, $V_{IH}$			2,4	-	2,4	-	2.4	-	2.4	-	V
Input Current (Low or High), $I_{IL}$ , $I_{IH}$		$V_{IN} = 0V$ or $+15V$	-	$\pm 1$	-	$\pm 1$	-	$\pm 1$	-	$\pm 1$	$\mu A$
Input Coding		See Tables 1 and 3	Binary/Offset Binary				Binary/Offset Binary				
Input Capacitance		(Note 4)	-	4	-	4	-	4	-	4	pF
<b>POWER SUPPLY CHARACTERISTICS</b>											
Power Supply Voltage Range		(Note 6)	+5 to +16				+5 to +16				V
$I_+$		All Digital Inputs High or Low (Excluding Ladder Network)	-	2	-	2.5	-	2	-	2.5	mA

**NOTES:**

2. Full Scale Range (FSR) is 10V for unipolar and  $\pm 10V$  for bipolar modes.
3. Using internal feedback resistor,  $R_{FEEDBACK}$ .
4. Guaranteed by design or characterization and not production tested.
5. Accuracy not guaranteed unless outputs at ground potential.
6. Accuracy is tested and guaranteed at  $V_+ = +15V$ , only.

### Definition of Terms

**Nonlinearity:** Error contributed by deviation of the DAC transfer function from a “best straight line” through the actual plot of transfer function. Normally expressed as a percentage of full scale range or in (sub)multiples of 1 LSB.

**Resolution:** It is addressing the smallest distinct analog output change that a D/A converter can produce. It is commonly expressed as the number of converter bits. A converter with resolution of  $n$  bits can resolve output changes of  $2^{-N}$  of the full-scale range, e.g.,  $2^{-N} V_{REF}$  for a unipolar conversion. Resolution by no means implies linearity.

**Settling Time:** Time required for the output of a DAC to settle to within specified error band around its final value (e.g.,  $1/2$  LSB) for a given digital input change, i.e., all digital inputs LOW to HIGH and HIGH to LOW.

**Gain Error:** The difference between actual and ideal analog output values at full-scale range, i.e., all digital inputs at HIGH state. It is expressed as a percentage of full scale range or in (sub)multiples of 1 LSB.

**Feedthrough Error:** Error caused by capacitive coupling from  $V_{REF}$  to  $I_{OUT1}$  with all digital inputs LOW.

**Output Capacitance:** Capacitance from  $I_{OUT1}$ , and  $I_{OUT2}$  terminals to ground.

**Output Leakage Current:** Current which appears on  $I_{OUT1}$ , terminal when all digital inputs are LOW or on  $I_{OUT2}$  terminal when all digital inputs are HIGH.

For further information on the use of this device, see the following Application Notes:

NOTE #	DESCRIPTION	AnswerFAX DOC. #
AN002	“Principles of Data Acquisition and Conversion”	9002
AN018	“Do’s and Don’ts of Applying A/D Converters”	9018
AN042	“Interpretation of Data Conversion Accuracy Specifications”	9042

## Detailed Description

The AD7523 and AD7533 are monolithic multiplying D/A converters. A highly stable thin film R-2R resistor ladder network and NMOS SPDT switches form the basis of the converter circuit, CMOS level shifters permit low power TTL/CMOS compatible operation. An external voltage or current reference and an operational amplifier are all that is required for most voltage output applications.

A simplified equivalent circuit of the DAC is shown in the Functional Diagram. The NMOS SPDT switches steer the ladder leg currents between  $I_{OUT1}$  and  $I_{OUT2}$  buses which must be held at ground potential. This configuration maintains a constant current in each ladder leg independent of the input code.

Converter errors are further reduced by using separate metal interconnections between the major bits and the outputs. Use of high threshold switches reduce offset (leakage) errors to a negligible level.

The level shifter circuits are comprised of three inverters with positive feedback from the output of the second to the first, see Figure 1. This configuration results in TTL/CMOS compatible operation over the full military temperature range. With the ladder SPDT switches driven by the level shifter, each switch is binarily weighted for an ON resistance proportional to the respective ladder leg current. This assures a constant voltage drop across each switch, creating equipotential terminations for the 2R ladder resistors and high accurate leg currents.

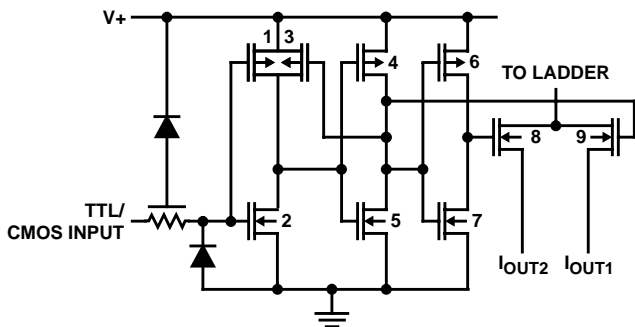
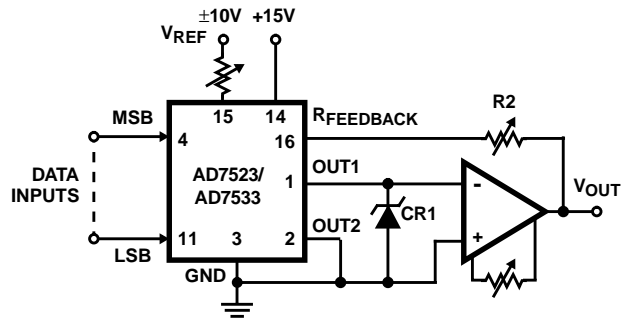

FIGURE 1. CMOS SWITCH

## Typical Applications

### Unipolar Binary Operation - AD7523 (8-Bit DAC)

The circuit configuration for operating the AD7523 in unipolar mode is shown in Figure 2. With positive and negative  $V_{REF}$  values the circuit is capable of 2-Quadrant multiplication. The "Digital Input Code/Analog Output Value" table for unipolar mode is given in Table 1.



NOTES:

1. R1 and R2 used only if gain adjustment is required.
2. CF1 protects AD7523 and AD7533 against negative transients.

FIGURE 2. UNIPOLAR BINARY OPERATION

TABLE 1. UNIPOLAR BINARY CODE - AD7523

DIGITAL INPUT MSB LSB	ANALOG OUTPUT
11111111	$-V_{REF} \left( \frac{255}{256} \right)$
10000001	$-V_{REF} \left( \frac{129}{256} \right)$
10000000	$-V_{REF} \left( \frac{128}{256} \right) = -\frac{V_{REF}}{2}$
01111111	$-V_{REF} \left( \frac{127}{256} \right)$
00000001	$-V_{REF} \left( \frac{1}{256} \right)$
00000000	$-V_{REF} \left( \frac{0}{256} \right) = 0$

NOTE:

1.  $1 \text{ LSB} = (2^{-8})(V_{REF}) = \left( \frac{1}{256} \right)(V_{REF})$ .

### Zero Offset Adjustment

1. Connect all digital inputs to GND.
2. Adjust the offset zero adjust trimpot of the output operational amplifier for  $0V \pm 1mV$  (Max) at  $V_{OUT}$ .

### Gain Adjustment

1. Connect all digital inputs to  $V+$ .
2. Monitor  $V_{OUT}$  for a  $-V_{REF} (1^{1/2^8})$  reading.
3. To increase  $V_{OUT}$ , connect a series resistor, R2, ( $0\Omega$  to  $250\Omega$ ) in the  $I_{OUT1}$  amplifier feedback loop.
4. To decrease  $V_{OUT}$ , connect a series resistor, R1, ( $0\Omega$  to  $250\Omega$ ) between the reference voltage and the  $V_{REF}$  terminal.

**Unipolar Binary Operation - AD7533 (10-Bit DAC)**

The circuit configuration for operating the AD7533 in unipolar mode is shown in Figure 2. With positive and negative  $V_{REF}$  values the circuit is capable of 2-Quadrant multiplication. The "Digital Input Code/Analog Output Value" table for unipolar mode is given in Table 2.

**TABLE 2. UNIPOLAR BINARY CODE - AD7533**

DIGITAL INPUT MSB LSB	(NOTE 1) NOMINAL ANALOG OUTPUT
1111111111	$-V_{REF} \left( \frac{1023}{1024} \right)$
1000000001	$-V_{REF} \left( \frac{513}{1024} \right)$
1000000000	$-V_{REF} \left( \frac{512}{1024} \right) = -\frac{V_{REF}}{2}$
0111111111	$-V_{REF} \left( \frac{511}{1024} \right)$
0000000001	$-V_{REF} \left( \frac{1}{1024} \right)$
0000000000	$-V_{REF} \left( \frac{0}{1024} \right) = 0$

**NOTES:**

- $V_{OUT}$  as shown in the Functional Diagram.
- Nominal Full Scale for the circuit of Figure 2 is given by:  

$$FS = -V_{REF} \left( \frac{1023}{1024} \right)$$
- Nominal LSB magnitude for the circuit of Figure 2 is given by:  

$$LSB = V_{REF} \left( \frac{1}{1024} \right)$$

**Zero Offset Adjustment**

- Connect all digital inputs to GND.
- Adjust the offset zero adjust trimpot of the output operational amplifier for  $0V \pm 1mV$  (Max) at  $V_{OUT}$ .

**Gain Adjustment**

- Connect all digital inputs to  $V+$ .
- Monitor  $V_{OUT}$  for a  $-V_{REF} (1 - 1/2^{10})$  reading.

- To increase  $V_{OUT}$ , connect a series resistor,  $R_2$ , ( $0\Omega$  to  $250\Omega$ ) in the  $I_{OUT1}$  amplifier feedback loop.
- To decrease  $V_{OUT}$ , connect a series resistor,  $R_1$ , ( $0\Omega$  to  $250\Omega$ ) between the reference voltage and the  $V_{REF}$  terminal.

**Bipolar (Offset Binary) Operation - AD7523**

The circuit configuration for operating the AD7523 in the bipolar mode is given in Figure 3. Using offset binary digital input codes and positive and negative reference voltage values, Four-Quadrant multiplication can be realized. The "Digital Input Code/Analog Output Value" table for bipolar mode is given in Table 3.)

A "Logic 1" input at any digital input forces the corresponding ladder switch to steer the bit current to  $I_{OUT1}$  bus. A "Logic 0" input forces the bit current to  $I_{OUT2}$  bus. For any code the  $I_{OUT1}$  and  $I_{OUT2}$  bus currents are complements of one another. The current amplifier at  $I_{OUT2}$  changes the polarity of  $I_{OUT2}$  current and the transconductance amplifier at  $I_{OUT}$  output sums the two currents. This configuration doubles the output range. The difference current resulting at zero offset binary code, (MSB = "Logic 1", all other bits = "Logic 0"), is corrected by using an external resistor, ( $10M\Omega$ ), from  $V_{REF}$  to  $I_{OUT2}$  (Figure 3).

**TABLE 3. BIPOlar (OFFSET BINARY) CODE - AD7523**

DIGITAL INPUT MSB LSB	ANALOG OUTPUT
1111111111	$-V_{REF} \left( \frac{127}{128} \right)$
100000001	$-V_{REF} \left( \frac{1}{128} \right)$
100000000	0
0111111111	$+V_{REF} \left( \frac{1}{128} \right)$
000000001	$+V_{REF} \left( \frac{127}{128} \right)$
000000000	$+V_{REF} \left( \frac{128}{128} \right)$

**NOTE:**

- $1 \text{ LSB} = (2^{-7})(V_{REF}) = \left( \frac{1}{128} \right)(V_{REF})$ .

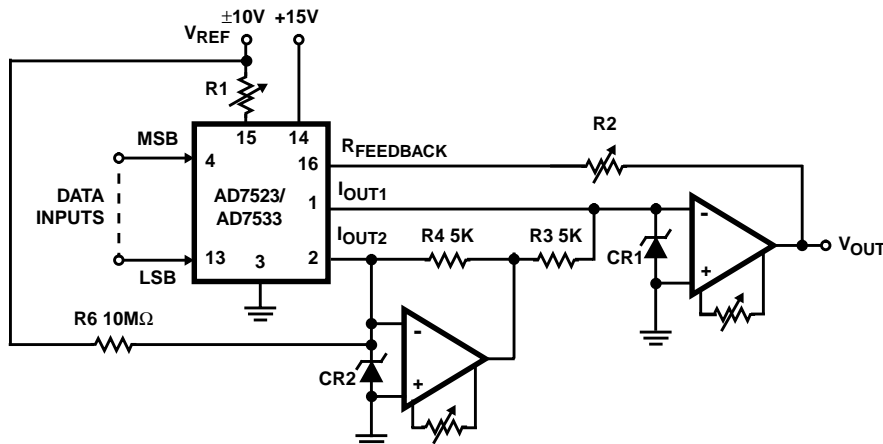

**FIGURE 3. BIPOlar OPERATION (4-QUADRANT MULTIPLICATION)**

**Offset Adjustment**

1. Adjust  $V_{REF}$  to approximately +10V.
2. Connect all digital inputs to "Logic 1".
3. Adjust  $I_{OUT2}$  amplifier offset adjust trimpot for  $0V \pm 1mV$  at  $I_{OUT2}$  amplifier output.
4. Connect MSB (Bit 1) to "Logic 1" and all other bits to "Logic 0".
5. Adjust  $I_{OUT1}$  amplifier offset adjust trimpot for  $0V \pm 1mV$  at  $V_{OUT}$ .

**Gain Adjustment**

1. Connect all digital inputs to  $V+$ .
2. Monitor  $V_{OUT}$  for a  $-V_{REF} (1^{1/2}^8)$  volts reading.
3. To increase  $V_{OUT}$ , connect a series resistor,  $R_2$ , of up to  $250\Omega$  between  $V_{OUT}$  and  $R_{FEEDBACK}$ .
4. To decrease  $V_{OUT}$ , connect a series resistor,  $R_1$ , of up to  $250\Omega$  between the reference voltage and the  $V_{REF}$  terminal.

**Bipolar (Offset Binary) Operation - AD7533**

The circuit configuration for operating the AD7533 in the bipolar mode is given in Figure 3. Using offset binary digital input codes and positive and negative reference voltage values, 4-Quadrant multiplication can be realized. The "Digital Input Code/Analog Output Value" table for bipolar mode is given in Table 4.

A "Logic 1" input at any digital input forces the corresponding ladder switch to steer the bit current to  $I_{OUT1}$  bus. A "Logic 0" input forces the bit current to  $I_{OUT2}$  bus. For any code the  $I_{OUT1}$  and  $I_{OUT2}$  bus currents are complements of one

another. The current amplifier at  $I_{OUT2}$  changes the polarity of  $I_{OUT2}$  current and the transconductance amplifier at  $I_{OUT1}$  output sums the two currents. This configuration doubles the output range. The difference current resulting at zero offset binary code, (MSB = "Logic 1", all other bits = "Logic 0"), is corrected by using an external resistor, ( $10M\Omega$ ), from  $V_{REF}$  to  $I_{OUT2}$ .

**TABLE 4. UNIPOLAR BINARY CODE - AD7533**

DIGITAL INPUT MSB LSB	(NOTE 1) NOMINAL ANALOG OUTPUT
1111111111	$-V_{REF} \left(\frac{511}{512}\right)$
1000000001	$-V_{REF} \left(\frac{1}{512}\right)$
1000000000	0
0111111111	$+V_{REF} \left(\frac{1}{512}\right)$
0000000001	$+V_{REF} \left(\frac{511}{512}\right)$
0000000000	$+V_{REF} \left(\frac{512}{512}\right)$

NOTES:

1.  $V_{OUT}$  as shown in the Functional Diagram.
2. Nominal Full Scale for the circuit of Figure 6 is given by:  

$$FSR = V_{REF} \left(\frac{1023}{512}\right).$$
3. Nominal LSB magnitude for the circuit of Figure 3 is given by:  

$$LSB = V_{REF} \left(\frac{1}{512}\right).$$

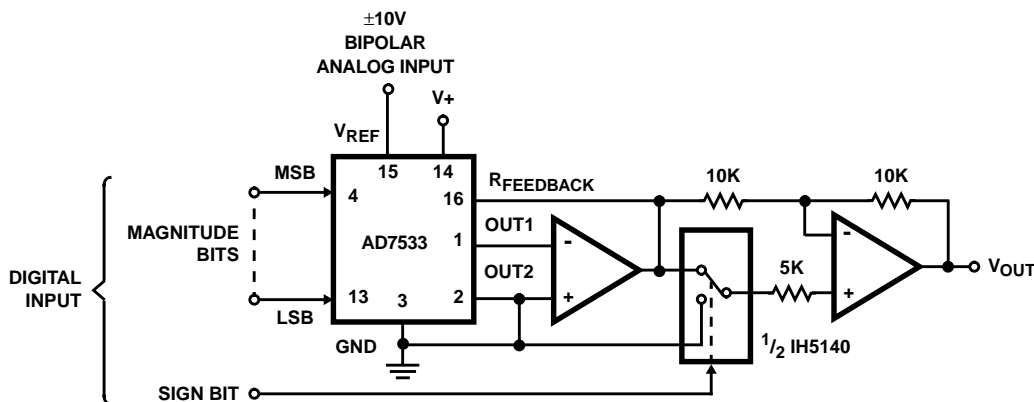

**FIGURE 4. 10-BIT AND SIGN MULTIPLYING DAC**

## AD7523, AD7533

### Offset Adjustment

1. Adjust  $V_{REF}$  to approximately +10V.
2. Connect all digital inputs to "Logic 1".
3. Adjust  $I_{OUT2}$  amplifier offset adjust trimpot for  $0V \pm 1mV$  at  $I_{OUT2}$  amplifier output.
4. Connect MSB (Bit 1) to "Logic 1" and all other bits to "Logic 0".
5. Adjust  $I_{OUT1}$  amplifier offset adjust trimpot for  $0V \pm 1mV$  at  $V_{OUT}$ .

### Gain Adjustment

1. Connect all digital inputs to  $V+$ .
2. Monitor  $V_{OUT}$  for a  $-V_{REF} (1 - 2^{-9})$  volts reading.
3. To increase  $V_{OUT}$ , connect a series resistor of up to  $250\Omega$  between  $V_{OUT}$  and  $R_{FEEDBACK}$ .
4. To decrease  $V_{OUT}$ , connect a series resistor of up to  $250\Omega$  between the reference voltage and the  $V_{REF}$  terminal.

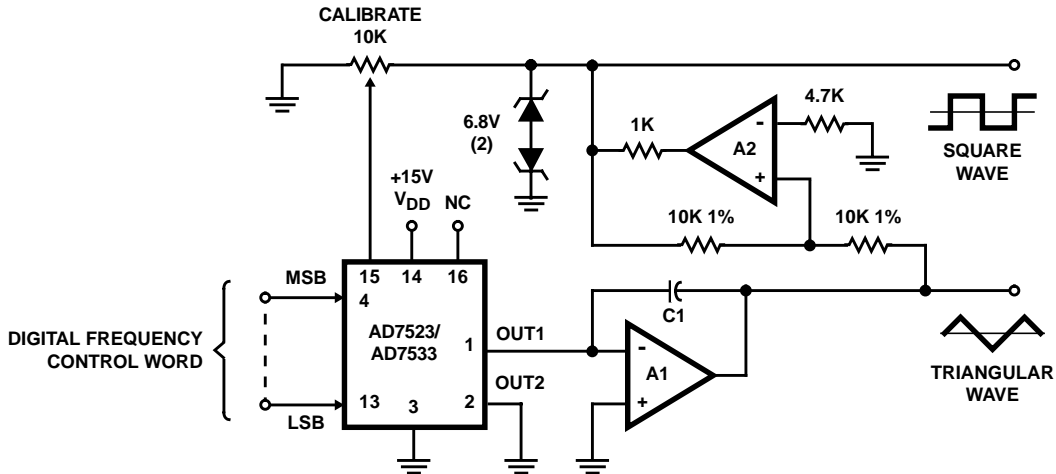
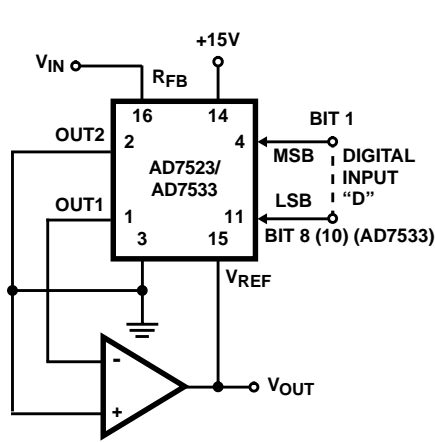

FIGURE 5. PROGRAMMABLE FUNCTION GENERATOR



$V_{OUT} = -V_{IN}/D$   
Where:

$$D = \frac{\text{Bit 1}}{2^1} + \frac{\text{Bit 2}}{2^2} + \dots + \frac{\text{Bit 8}}{2^8}$$

$$(0 \leq D \leq \frac{255}{256})$$

FIGURE 6. DIVIDER (DIGITALLY CONTROLLED GAIN)

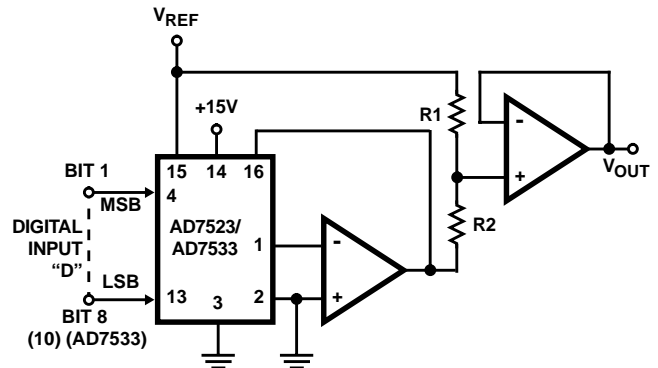

$$V_{OUT} = V_{REF} \left[ \left( \frac{R_2}{R_1 + R_2} \right) - \left( \frac{R_1 D}{R_1 + R_2} \right) \right]$$

$$\text{Where } D = \frac{\text{Bit 1}}{2^1} + \frac{\text{Bit 2}}{2^2} + \dots + \frac{\text{Bit 8}}{2^8}$$

$$(0 \leq D \leq \frac{255}{256})$$

FIGURE 7. MODIFIED SCALE FACTOR AND OFFSET

# AD7523, AD7533

## Die Characteristics

### DIE DIMENSIONS:

101 mils x 103 mils (2565micrms x 2616micrms)

### METALLIZATION:

Type: Pure Aluminum  
 Thickness:  $10 \pm 1 \text{ k\AA}$

### PASSIVATION:

Type: PSG/Nitride  
 PSG:  $7 \pm 1.4 \text{ k\AA}$   
 Nitride:  $8 \pm 1.2 \text{ k\AA}$

### PROCESS:

CMOS Metal Gate

## Metallization Mask Layout

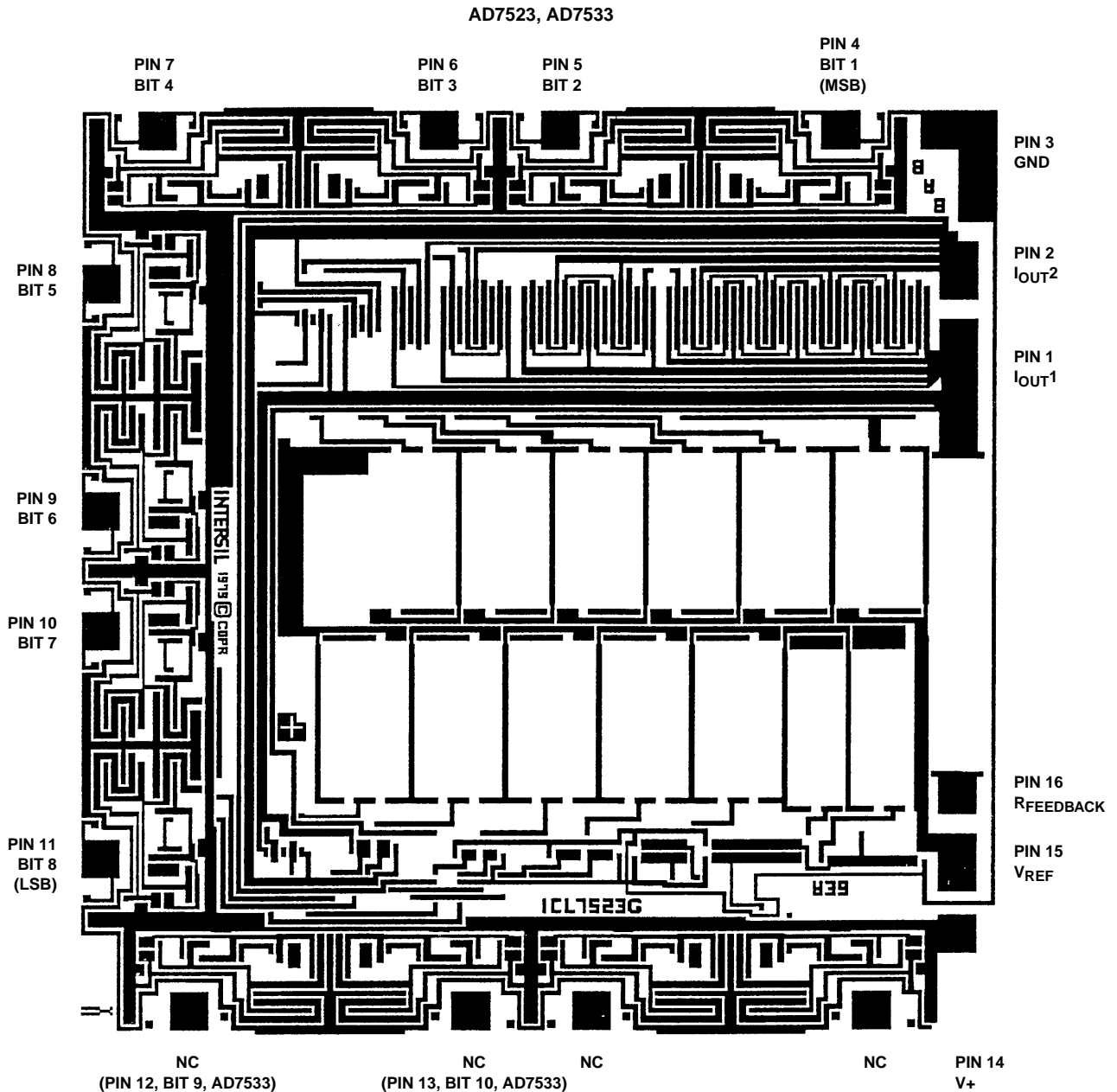

All Intersil semiconductor products are manufactured, assembled and tested under **ISO9000** quality systems certification.

*Intersil products are sold by description only. Intersil Corporation reserves the right to make changes in circuit design and/or specifications at any time without notice. Accordingly, the reader is cautioned to verify that data sheets are current before placing orders. Information furnished by Intersil is believed to be accurate and reliable. However, no responsibility is assumed by Intersil or its subsidiaries for its use; nor for any infringements of patents or other rights of third parties which may result from its use. No license is granted by implication or otherwise under any patent or patent rights of Intersil or its subsidiaries.*

For information regarding Intersil Corporation and its products, see web site <http://www.intersil.com>

### **Sales Office Headquarters**

#### **NORTH AMERICA**

Intersil Corporation  
P. O. Box 883, Mail Stop 53-204  
Melbourne, FL 32902  
TEL: (407) 724-7000  
FAX: (407) 724-7240

#### **EUROPE**

Intersil SA  
Mercure Center  
100, Rue de la Fusee  
1130 Brussels, Belgium  
TEL: (32) 2.724.2111  
FAX: (32) 2.724.22.05

#### **ASIA**

Intersil (Taiwan) Ltd.  
Taiwan Limited  
7F-6, No. 101 Fu Hsing North Road  
Taipei, Taiwan  
Republic of China  
TEL: (886) 2 2716 9310  
FAX: (886) 2 2715 3029

This datasheet has been downloaded from:

[www.DatasheetCatalog.com](http://www.DatasheetCatalog.com)

Datasheets for electronic components.



LittleDiode supplies new, hard to find or obsolete electronic components and semiconductors all over the world.

With over two million different components listed you are sure to find the part you need.

Feel free to visit us today at our online store:

[LittleDiode.com](http://LittleDiode.com)

Looking forward to providing you with the best possible service.