

256 K × 4-Bit Dynamic RAM Low Power 256 K × 4-Bit Dynamic RAM

HYB 514256B/BJ-50/-60/-70 HYB 514256BL/BJL-50/-60/-70

Advanced Information

- 262 144 words by 4-bit organization
- Fast access and cycle time
50 ns access time
95 ns cycle time (-50 version)
60 ns access time
110 ns cycle time (-60 version)
70 ns access time
130 ns cycle time (-70 version)
- Fast page mode cycle time
35 ns (-50 version)
40 ns (-60 version)
45 ns (-70 version)
- Low power dissipation
max. 495 mW active (-50 version)
max. 440 mW active (-60 version)
max. 385 mW active (-70 version)
max. 5.5 mW standby
max. 1.1 mW standby for L-version
- Single + 5 V ($\pm 10\%$) supply with a built-in V_{BB} generator
- Output unlatched at cycle end allows two-dimensional chip selection
- Read-modify-write, \overline{CAS} -before- \overline{RAS} refresh, \overline{RAS} -only refresh, hidden-refresh and fast page mode capability
- All inputs, outputs and clocks TTL-compatible
- 512 refresh cycles/8 ms
512 refresh cycles/64 ms for L-version only
- Plastic Packages: P-DIP-20-2,
P-SOJ-26/20-1

Ordering Information

Type	Ordering Code	Package	Description
HYB 514256B-50	Q67100-Q1044	P-DIP-20-2	DRAM (access time 50ns)
HYB 514256B-60	Q67100-Q530	P-DIP-20-2	DRAM (access time 60 ns)
HYB 514256B-70	Q67100-Q433	P-DIP-20-2	DRAM (access time 70 ns)
HYB 514256BJ-50	Q67100-Q1054	P-SOJ-26/20-1	DRAM (access time 50 ns)
HYB 514256BJ-60	Q67100-Q536	P-SOJ-26/20-1	DRAM (access time 60 ns)
HYB 514256BJ-70	Q67100-Q537	P-SOJ-26/20-1	DRAM (access time 70 ns)
HYB 514256BL-50	on request	P-DIP-20-2	DRAM (access time 50 ns)
HYB 514256BL-60	Q67100-Q542	P-DIP-20-2	DRAM (access time 60 ns)
HYB 514256BL-70	Q67100-Q543	P-DIP-20-2	DRAM (access time 70 ns)
HYB 514256BJL-50	on request	P-SOJ-26/20-1	DRAM (access time 50 ns)
HYB 514256BJL-60	Q67100-Q608	P-SOJ-26/20-1	DRAM (access time 60 ns)
HYB 514256BJL-70	Q67100-Q607	P-SOJ-26/20-1	DRAM (access time 70 ns)

The HYB 514256B/BJ/BL/BJL is the new generation dynamic RAM organized as 262 144 words by 4-bit. The HYB 514256B/BJ/BL/BJL utilizes CMOS silicon gate process technology as well as advanced circuit techniques to provide wide operating margins, both internally and for the system user. Multiplexed address inputs permit the HYB 514256B/BJ/BL/BJL to be packaged in a standard plastic P-DIP-20-2, or plastic P-SOJ-26/20-1. This package size provides high system bit densities and is compatible with commonly used automatic testing and insertion equipment. System oriented features include single + 5 V (± 10 %) power supply, direct interfacing with high-performance logic device families such as Schottky TTL. These HYB 514256BL/BJL are specially selected for battery backup applications.

Pin Definitions and Functions

Pin No.	Function
A0-A8	Address Inputs
$\overline{\text{RAS}}$	Row Address Strobe
$\overline{\text{OE}}$	Output Enable
I/O1-I/O4	Data Input/Output
$\overline{\text{CAS}}$	Column Address Strobe
$\overline{\text{WE}}$	Read/Write Input
V_{CC}	Power Supply (+ 5 V)
V_{SS}	Ground (0 V)
N.C.	No Connection

Pin Configuration (top view)

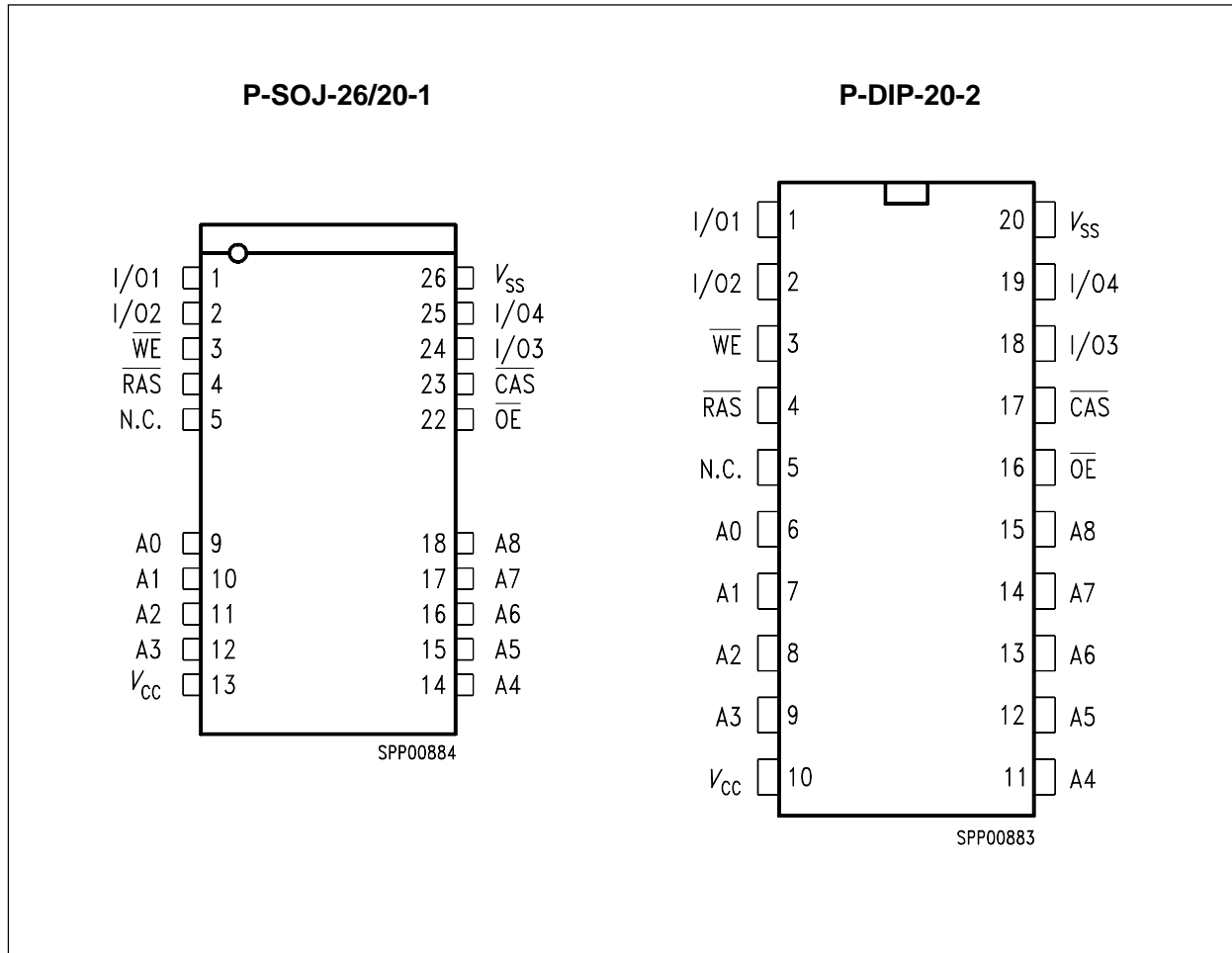

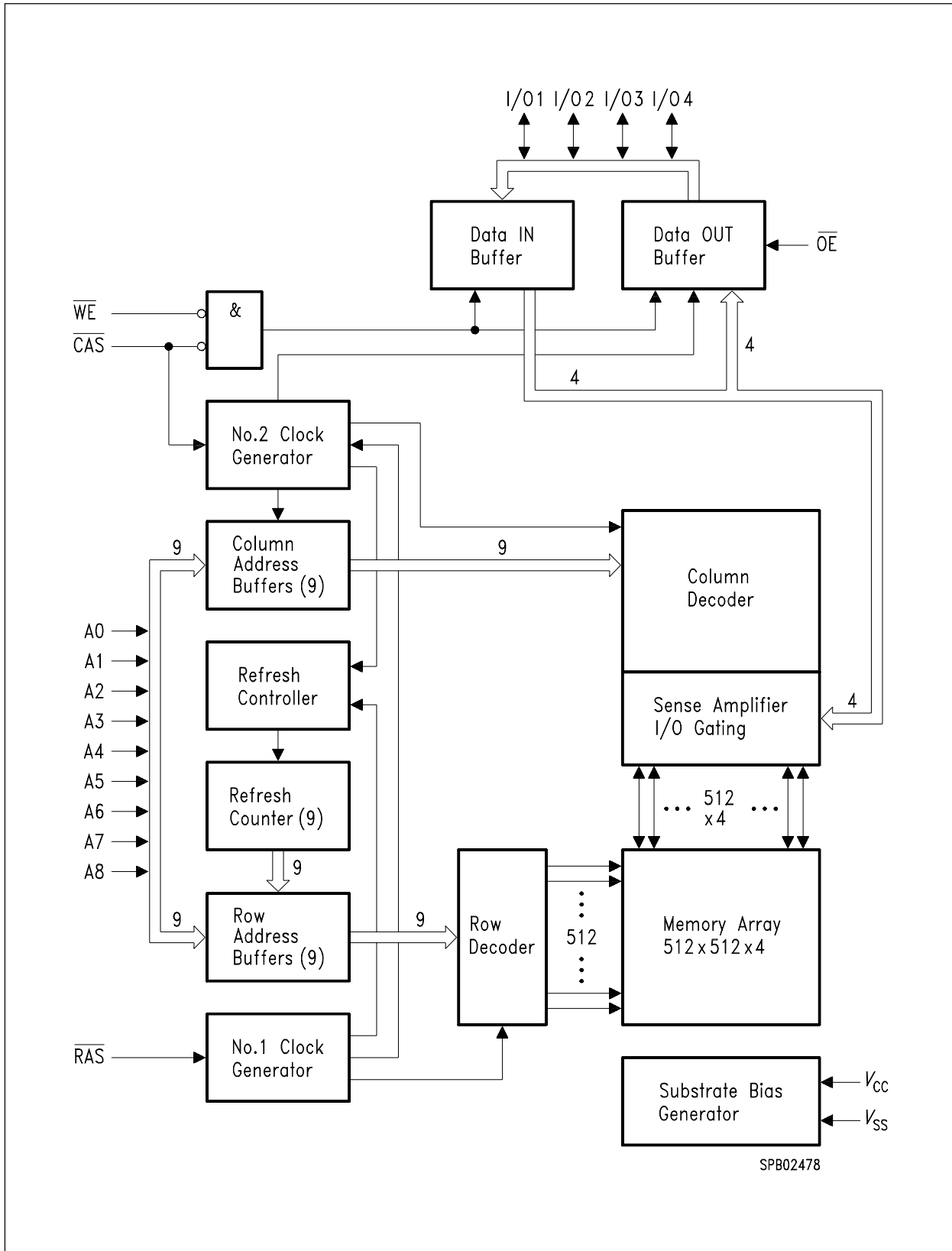

Block Diagram

Absolute Maximum Ratings

Operating temperature range	0 to + 70 °C
Storage temperature range.....	- 55 to + 150 °C
Soldering temperature	260 °C
Soldering time	10 s
Input/output voltage	- 1 to + 7 V
Power supply voltage.....	- 1 to + 7 V
Power dissipation.....	0.6 W
Data out current (short circuit)	50 mA

Note: Stresses above those listed under “Absolute Maximum Ratings” may cause permanent damage of the device. Exposure to absolute maximum rating conditions for extended periods may affect device reliability.

DC Characteristics

$T_A = 0$ to 70 °C; $V_{SS} = 0$ V; $V_{CC} = 5$ V \pm 10 %

Parameter	Symbol	Limit Values		Unit	Test Condition
		min.	max.		
Input high voltage	V_{IH}	2.4	6.5	V	¹⁾
Input low voltage	V_{IL}	- 1.0	0.8	V	¹⁾
Output high voltage ($I_{OUT} = - 5$ mA)	V_{OH}	2.4	-	V	¹⁾
Output low voltage ($I_{OUT} = 4.2$ mA)	V_{OL}	-	0.4	V	¹⁾
Input leakage current, any input (0 V $\leq V_{IN} \leq 6.5$ V, all other pins = 0 V)	$I_{I(L)}$	- 10	10	μ A	¹⁾
Output leakage current (DO is disabled, 0 V $\leq V_{OUT} \leq V_{CC}$)	$I_{O(L)}$	- 10	10	μ A	¹⁾
Average V_{CC} supply current: -50 version -60 version -70 version (\overline{RAS} , \overline{CAS} , address cycling: $t_{RC} = t_{RC}$ min.)	I_{CC1}	-	90 80 70	mA mA mA	^{2) 3)} ^{2) 3)} ^{2) 3)}
Standby V_{CC} supply current ($\overline{RAS} = \overline{CAS} = V_{IH}$)	I_{CC2}	-	2	mA	-
Average V_{CC} supply current, \overline{RAS} only mode: -50 version -60 version -70 version (\overline{RAS} cycling: $\overline{CAS} = V_{IH}$; $t_{RC} = t_{RC}$ min.)	I_{CC3}	-	90 80 70	mA mA mA	²⁾ ²⁾ ²⁾

DC Characteristics (cont'd)

$T_A = 0$ to 70 °C; $V_{SS} = 0$ V; $V_{CC} = 5$ V \pm 10 %

Parameter	Symbol	Limit Values		Unit	Test Condition
		min.	max.		
Average V_{CC} supply current, fast page mode: -60 version -70 version -50 version ($\overline{RAS} = V_{IL}$, \overline{CAS} , address cycling: $t_{PC} = t_{PC}$ min.)	I_{CC4}	— — —	70 60 50	mA mA mA	2) 3) 2) 3) 2) 3)
Standby V_{CC} supply current L-Version ($\overline{RAS} = \overline{CAS} = V_{CC} - 0.2$ V)	I_{CC5}	— —	1 200	mA μ A	1) 1)
Average V_{CC} supply current, \overline{CAS} -before- \overline{RAS} refresh mode: -50 version -60 version -70 version (\overline{RAS} , \overline{CAS} cycling: $t_{RC} = t_{RC}$ min.)	I_{CC6}	— — —	90 80 70	mA mA mA	2) 2) 2)
For L-version only: Battery backup current: average power supply current, battery backup mode: ($\overline{CAS} = \overline{CAS}$ before \overline{RAS} cycling or 0.2 V, $\overline{OE} = V_{CC} - 0.2$ V $\overline{WE} = V_{CC} - 0.2$ V or 0.2 V, A0 to A8 = $V_{CC} - 0.2$ V or 0.2 V, I/O1 to I/O4 = $V_{CC} - 0.2$ V or 0.2 V or open, $t_{RC} = 125$ μ s, $t_{RAS} = t_{RAS}$ min. \sim 1 μ s)	I_{CC7}	—	300	μ A	2)

AC Characteristics ^{4) 13)}

$T_A = 0$ to 70 °C; $V_{CC} = 5$ V \pm 10 %; $t_T = 5$ ns

Parameter	Symbol	Limit Values						Unit
		-50		-60		-70		
		min.	max.	min.	max.	min.	max.	
Random read or write cycle time	t_{RC}	95	–	110	–	130	–	ns
Read-modify-write cycle time	t_{RWC}	140	–	160	–	185	–	ns
Fast page mode cycle time	t_{PC}	35	–	40	–	45	–	ns
Fast page mode read-modify-write cycle time	t_{PRWC}	80	–	90	–	100	–	ns
Access time from \overline{RAS} ^{6) 11)}	t_{RAC}	–	50	–	60	–	70	ns
Access time from \overline{CAS} ^{6) 11)}	t_{CAC}	–	15	–	15	–	20	ns
Access time from column address ^{6) 12)}	t_{AA}	–	25	–	30	–	35	ns
Access time from \overline{CAS} precharge ^{6) 12)}	t_{CPA}	–	30	–	35	–	40	ns
\overline{CAS} to output in low-Z ⁴⁾	t_{CLZ}	0	–	0	–	0	–	ns
Output buffer turn-off delay ⁷⁾	t_{OFF}	0	15	0	20	0	20	ns
Transition time (rise and fall) ⁵⁾	t_T	3	50	3	50	3	50	ns
\overline{RAS} precharge time	t_{RP}	35	–	40	–	50	–	ns
\overline{RAS} pulse width	t_{RAS}	50	10.000	60	10.000	70	10.000	ns
\overline{RAS} pulse width (fast page mode)	t_{RASP}	50	100.000	60	100.000	70	100.000	ns
\overline{RAS} hold time	t_{RSH}	15	–	15	–	20	–	ns
\overline{CAS} hold time	t_{CSH}	50	–	60	–	70	–	ns
\overline{CAS} pulse width	t_{CAS}	15	10.000	15	10.000	20	10.000	ns
\overline{RAS} hold time from \overline{CAS} precharge (Fast Page Mode)	t_{RHCP}	30	–	35	–	45	–	ns
\overline{CAS} precharge to \overline{WE} delay time (FPM RMW)	t_{CPWD}	55	–	60	–	65	–	ns
\overline{RAS} to \overline{CAS} delay time ¹¹⁾	t_{RCD}	20	35	20	45	20	50	
\overline{RAS} to column address delay time ¹²⁾	t_{RAD}	15	25	15	30	15	35	ns
\overline{CAS} to \overline{RAS} precharge time	t_{CRP}	5	–	5	–	5	–	ns
\overline{CAS} precharge time	t_{CP}	10	–	10	–	10	–	ns

AC Characteristics (cont'd)^{4) 13)}

$T_A = 0$ to 70 °C; $V_{CC} = 5$ V \pm 10 %; $t_T = 5$ ns

Parameter	Symbol	Limit Values						Unit
		-50		-60		-70		
		min.	max.	min.	max.	min.	max.	
Row address setup time	t_{ASR}	0	–	0	–	0	–	ns
Row address hold time	t_{RAH}	10	–	10	–	10	–	ns
Column address setup time	t_{ASC}	0	–	0	–	0	–	ns
Column address hold time	t_{CAH}	10	–	15	–	15	–	ns
Column address to \overline{RAS} lead time	t_{RAL}	25	–	30	–	35	–	ns
Read command setup time	t_{RCS}	0	–	0	–	0	–	ns
Read command hold time ⁸⁾	t_{RCH}	0	–	0	–	0	–	ns
Read command hold time referenced to \overline{RAS} ⁸⁾	t_{RRH}	0	–	0	–	0	–	ns
Write command hold time	t_{WCH}	10	–	10	–	15	–	ns
Write command pulse width	t_{WCP}	10	–	10	–	15	–	ns
Write command to \overline{RAS} lead time	t_{RWL}	15	–	15	–	20	–	ns
Write command to \overline{CAS} lead time	t_{CWL}	15	–	15	–	20	–	ns
Data setup time ⁹⁾	t_{DS}	0	–	0	–	0	–	ns
Data hold time ⁹⁾	t_{DH}	10	–	15	–	15	–	ns
Refresh period	t_{REF}	–	8	–	8	–	8	ms
Refresh period L-version	t_{REF}	–	64	–	64	–	–	ms
Write command setup time ¹⁰⁾	t_{WCS}	0	–	0	–	0	–	ns
\overline{CAS} to \overline{WE} delay time ¹⁰⁾	t_{CWD}	40	–	45	–	50	–	ns
\overline{RAS} to \overline{WE} delay time ¹⁰⁾	t_{RWD}	75	–	90	–	100	–	ns
Column address to \overline{WE} delay time ¹⁰⁾	t_{AWD}	50	–	60	–	65	–	ns
\overline{CAS} setup time (\overline{CAS} -before- \overline{RAS} cycle)	t_{CSR}	5	–	5	–	5	–	ns
\overline{CAS} hold time (\overline{CAS} -before- \overline{RAS} cycle)	t_{CHR}	10	–	15	–	15	–	ns
\overline{RAS} to \overline{CAS} precharge time	t_{RPC}	0	–	0	–	0	–	ns

AC Characteristics (cont'd) ^{4) 13)}

$T_A = 0$ to 70 °C; $V_{CC} = 5$ V \pm 10 %; $t_T = 5$ ns

Parameter	Symbol	Limit Values						Unit
		-50		-60		-70		
		min.	max.	min.	max.	min.	max.	
CAS precharge time ($\overline{\text{CAS}}$ -before-RAS counter test cycle)	t_{CPT}	25	–	30	–	40	–	ns
$\overline{\text{OE}}$ access time	t_{OEA}	–	15	–	15	–	20	ns
RAS hold time referenced to $\overline{\text{OE}}$	t_{ROH}	10	–	10	–	10	–	ns
Output buffer turn-off delay time from $\overline{\text{OE}}$	t_{OEZ}	0	15	0	20	0	20	ns
Data to $\overline{\text{CAS}}$ low delay ¹⁴⁾	t_{DZC}	0	–	0	–	0	–	ns
$\overline{\text{CAS}}$ high to data delay ¹⁵⁾	t_{DZO}	0	–	0	–	0	–	
$\overline{\text{OE}}$ high to data delay ¹⁵⁾	t_{CDD}	15	–	20	–	20	–	ns
$\overline{\text{OE}}$ to data delay ¹⁵⁾	t_{ODD}	15	–	20	–	20	–	ns

Capacitance

$T_A = 0$ to 70 °C; $V_{CC} = 5$ V \pm 10 %; $f = 1$ MHz

Parameter	Symbol	Limit Values		Unit
		min.	max.	
Input capacitance (A0 to A8)	C_{11}	–	5	pF
Input capacitance ($\overline{\text{RAS}}$, $\overline{\text{CAS}}$, $\overline{\text{WE}}$, $\overline{\text{OE}}$)	C_{12}	–	7	pF
Output capacitance (I/O1 ... I/O4)	C_{50}	–	7	pF

Notes :

- 1) All voltages are referenced to V_{SS} .
- 2) I_{CC1} , I_{CC3} , I_{CC4} , I_{CC6} and I_{CC7} depend on cycle rate.
- 3) I_{CC1} and I_{CC4} depend on output loading. Specified values are measured with the output open.
- 4) An initial pause of 200 μ s is required after power-up followed by 8 $\overline{\text{RAS}}$ cycles before proper device operation is achieved. In case of using internal refresh counter, a minimum of 8 CAS-before-RAS initialization cycles instead of 8 $\overline{\text{RAS}}$ cycles are required.
- 5) V_{IH} (min.) and V_{IL} (max.) are reference levels for measuring timing of input signals. Transition times are also measured between V_{IH} and V_{IL} .
- 6) Measured with a load equivalent to 2 TTL loads and 100 pF.
- 7) t_{OFF} (max.) and t_{OEZ} (max.) define the time at which the output achieves the open-circuit conditions and is not referenced to output voltage levels.
- 8) Either t_{RCH} or t_{RRH} must be satisfied for a read cycle.
- 9) These parameters are referenced to the $\overline{\text{CAS}}$ leading edge in early write cycles and to the $\overline{\text{WE}}$ leading edge in read-modify-write cycles.
- 10) t_{WCS} , t_{RWD} , t_{CWD} and t_{AWD} are not restrictive operating parameters. They are included in the data sheet as electrical characteristics only. If $t_{WCS} \geq t_{WCS}(\text{min.})$, the cycle is an early write cycle and data out pin will remain open circuit (high impedance) through the entire cycle; if $t_{RWD} \geq t_{RWD}(\text{min.})$, $t_{CWD} \geq t_{CWD}(\text{min.})$ and $t_{AWD} \geq t_{AWD}(\text{min.})$, the cycle is a read-modify-write cycle and I/O will contain data read from the selected cell. If neither of the above sets of conditions is satisfied, the condition of I/O (at access time) is indeterminate.
- 11) Operation within the $t_{RCD}(\text{max.})$ limit insures that $t_{RAC}(\text{max.})$ can be met, $t_{RCD}(\text{max.})$ is specified as a reference point only. If t_{RCD} is greater than the specified $t_{RCD}(\text{max.})$ limit, then access time is controlled by t_{CAC} .
- 12) Operation within the $t_{RAD}(\text{max.})$ limit insures that $t_{RAC}(\text{max.})$ can be met. $t_{RAD}(\text{max.})$ is specified as a reference point only. If t_{RAD} is greater than the specified $t_{RAD}(\text{max.})$ limit, then access time is controlled by t_{AA} .
- 13) AC measurements assume $t_T = 5\text{ns}$.
- 14) Either t_{DZC} or t_{DZO} must be satisfied.
- 15) Either t_{CDD} or t_{ODD} must be satisfied.

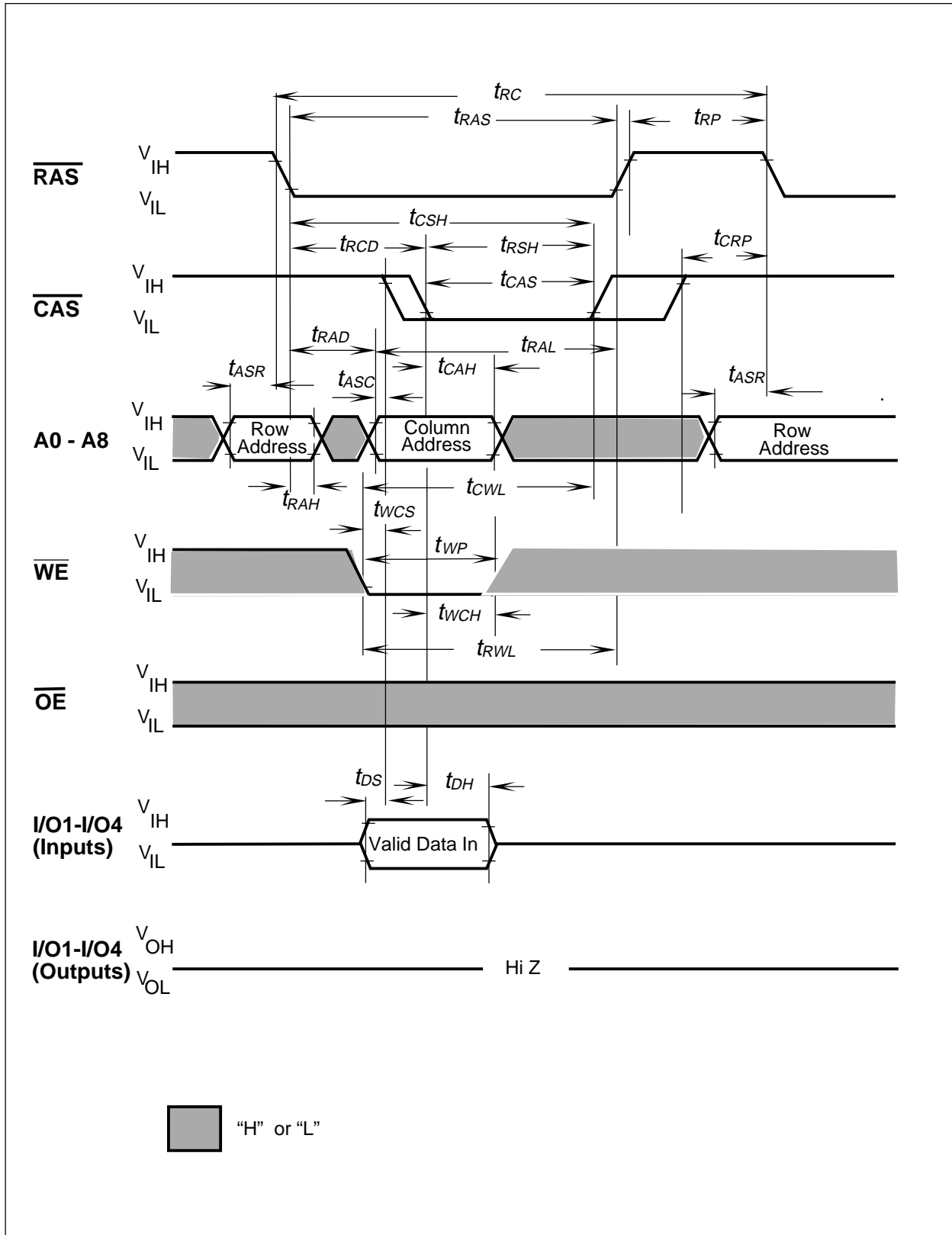

Write Cycle (Early Write)

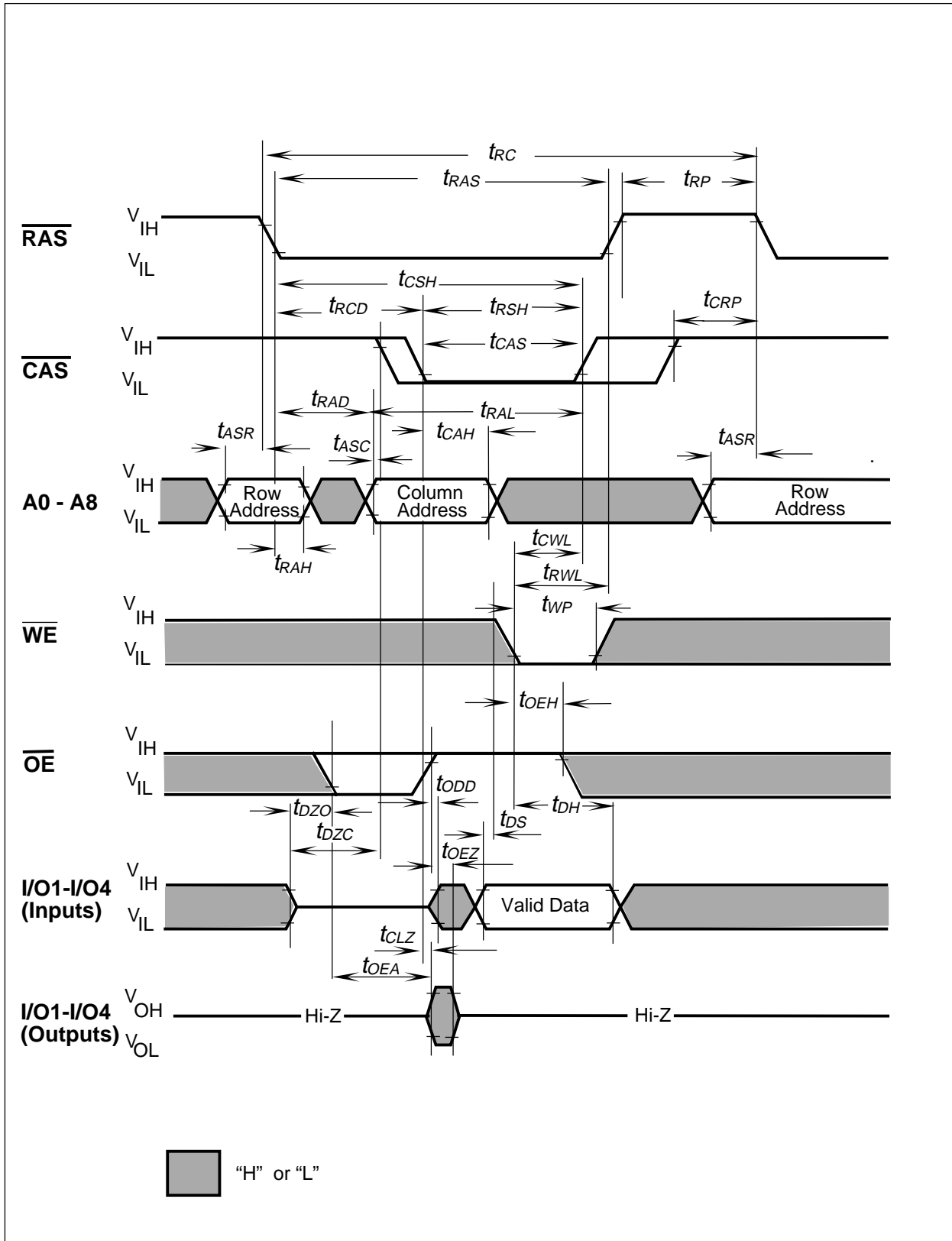

Write Cycle (\overline{OE} Controlled Write)

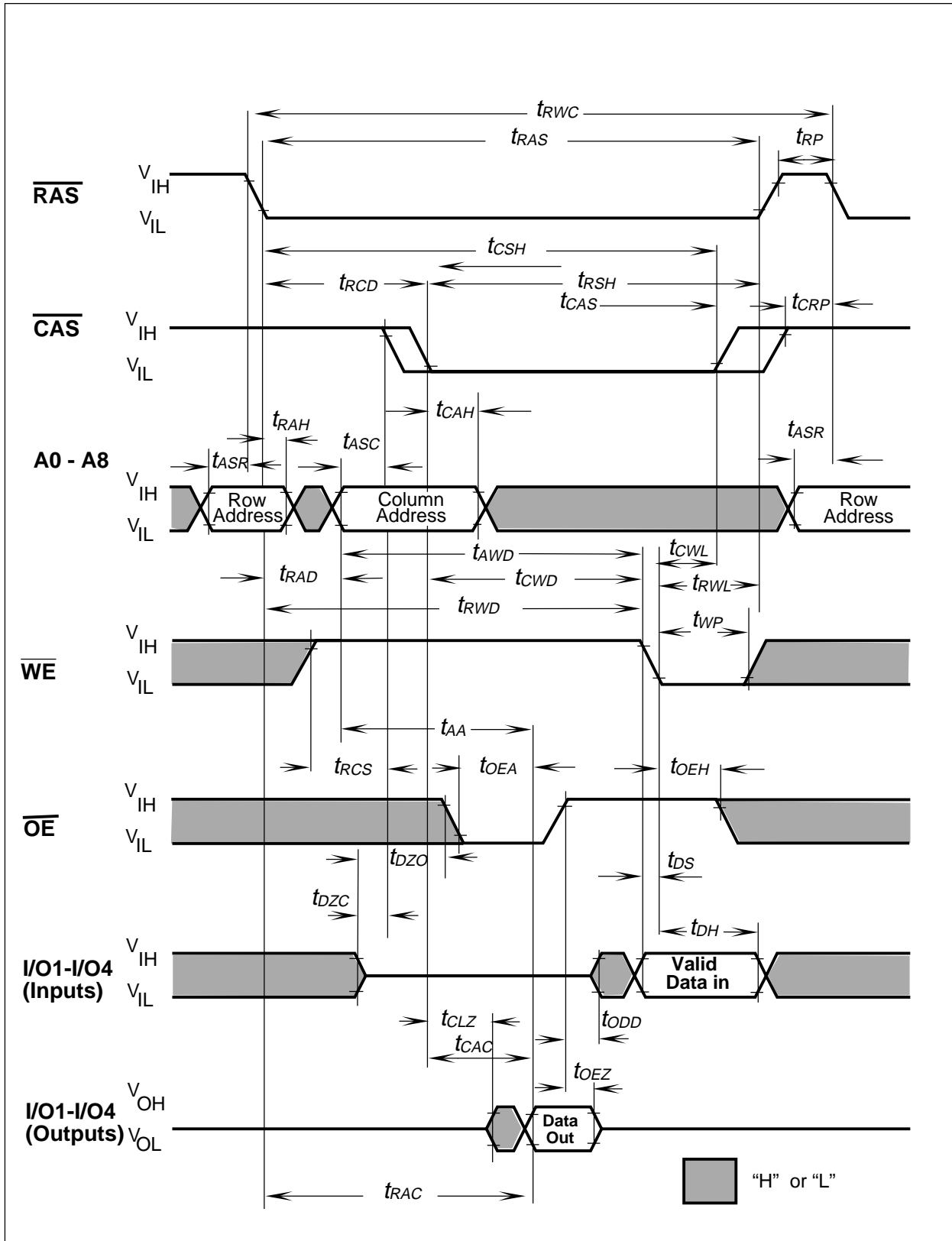

Read-Write (Read-Modify-Write) Cycle

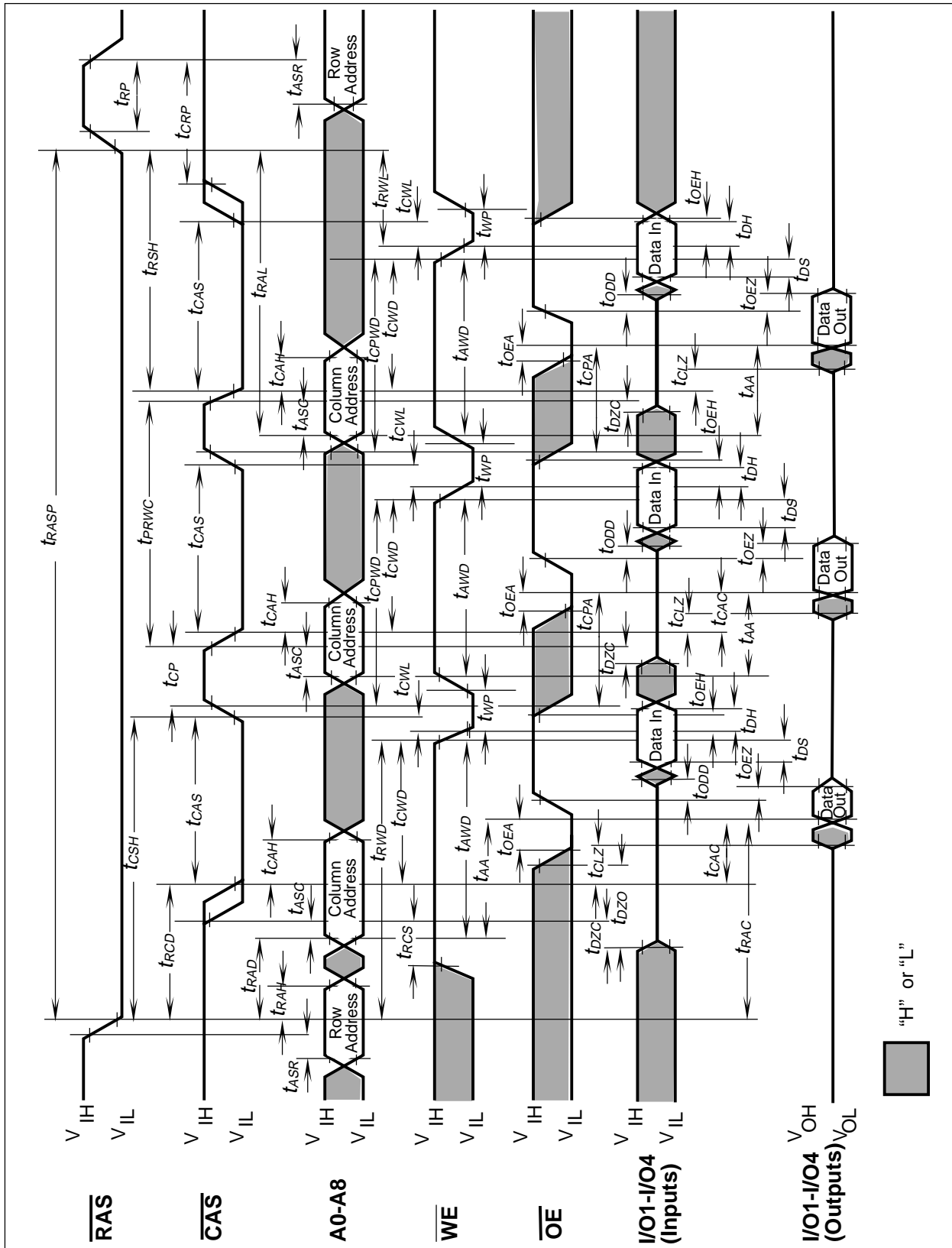

Fast Page Mode Read-Modify-Write Cycle

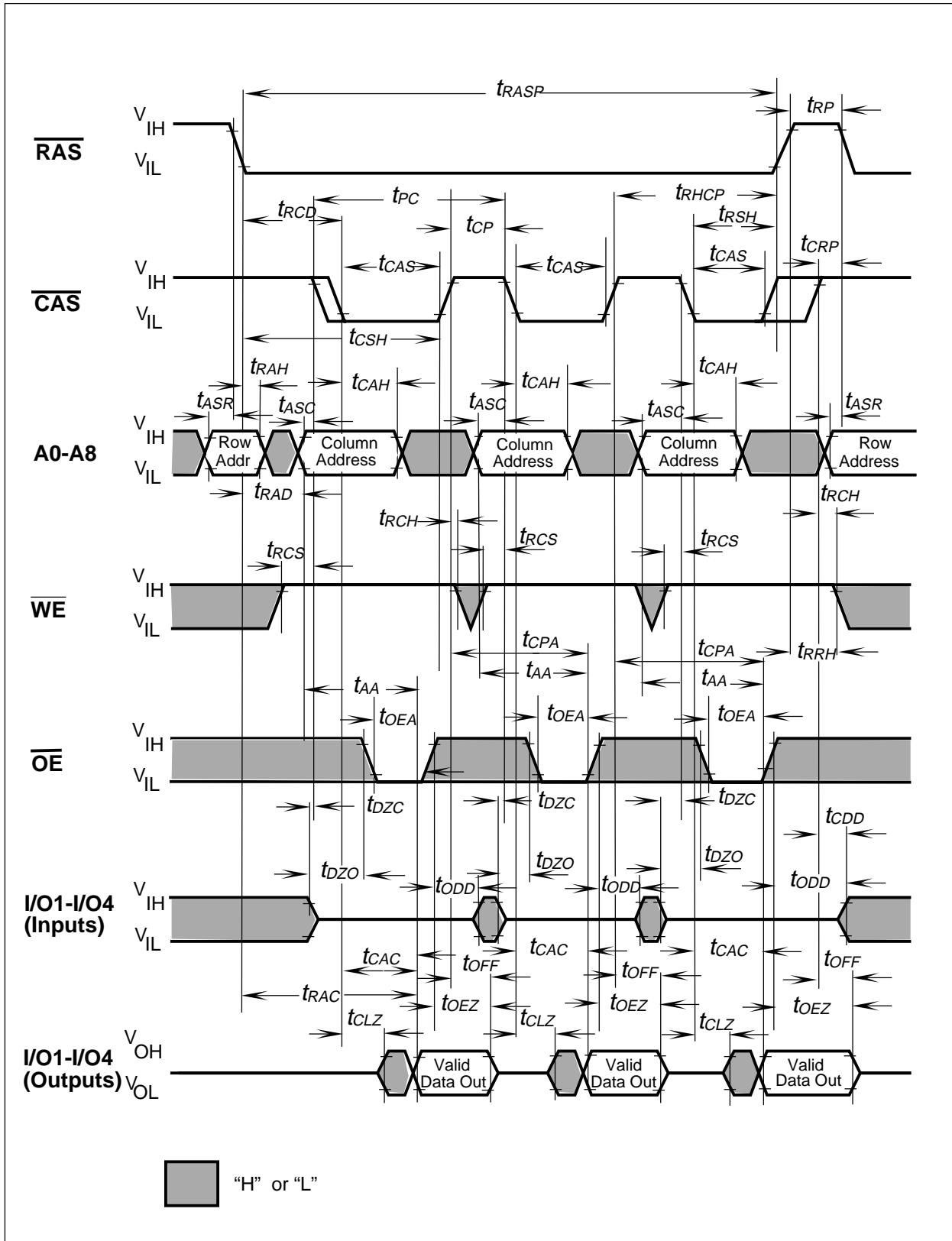

Fast Page Mode Read Cycle

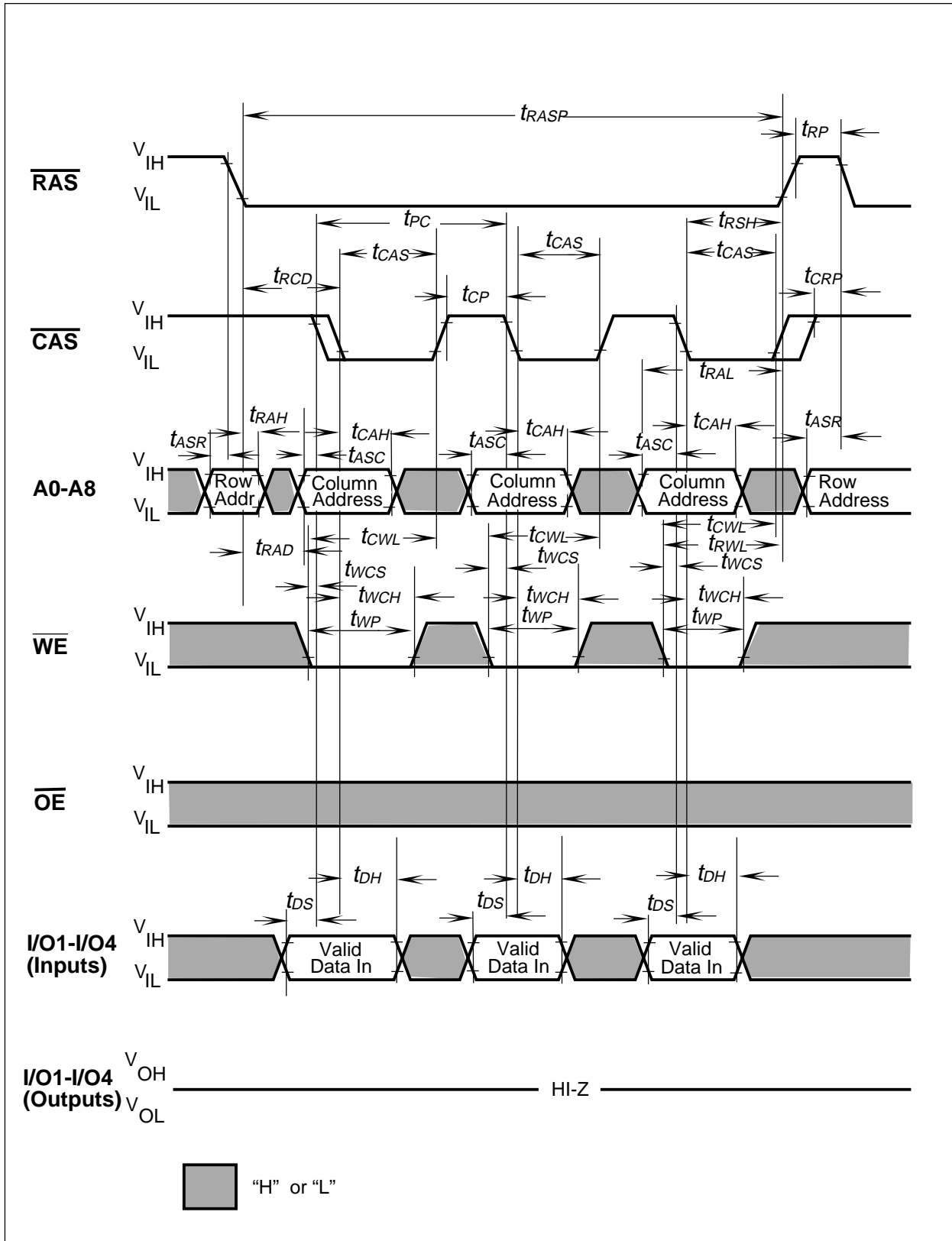

Fast Page Mode Early Write Cycle

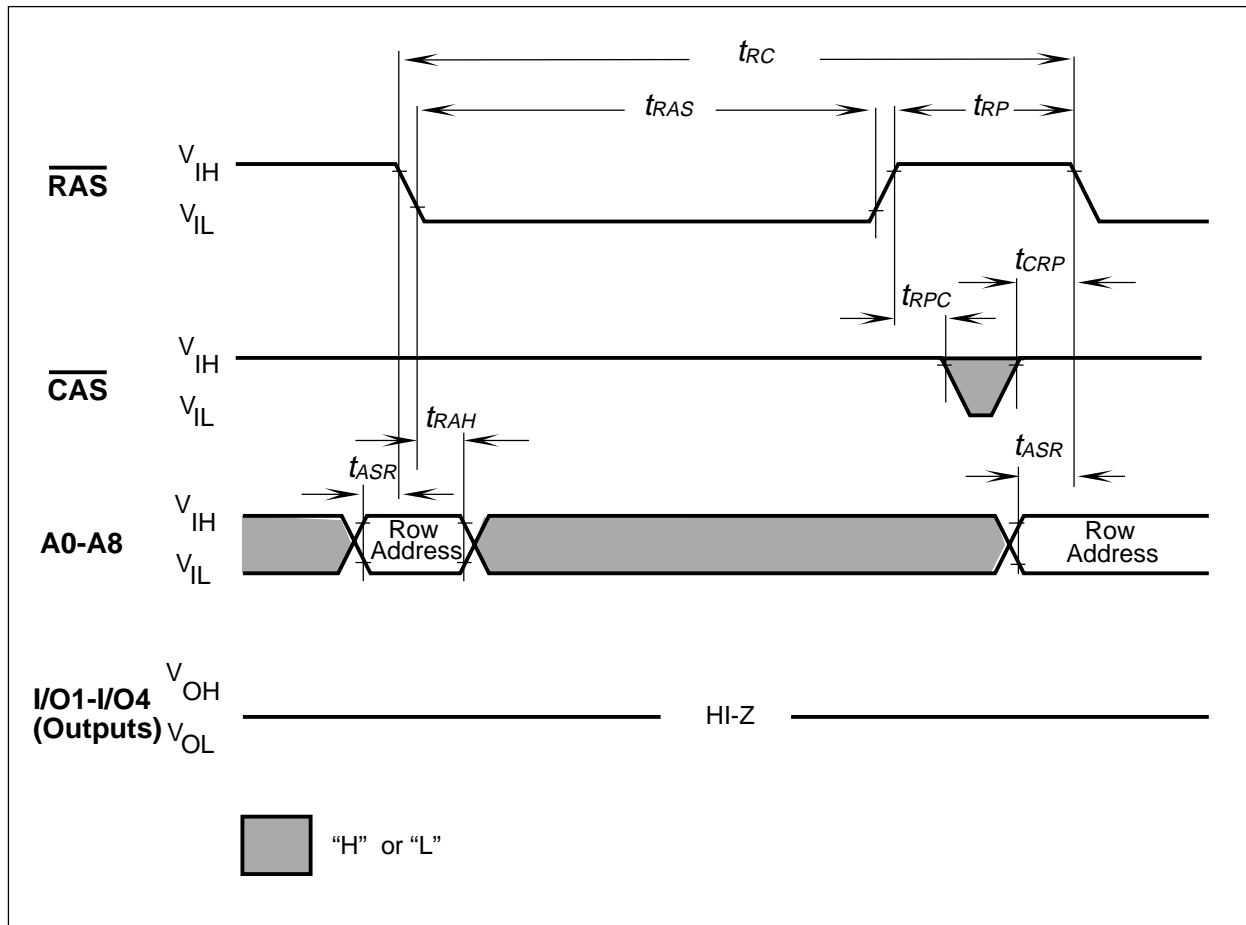

$\overline{\text{RAS}}$ -Only Refresh Cycle

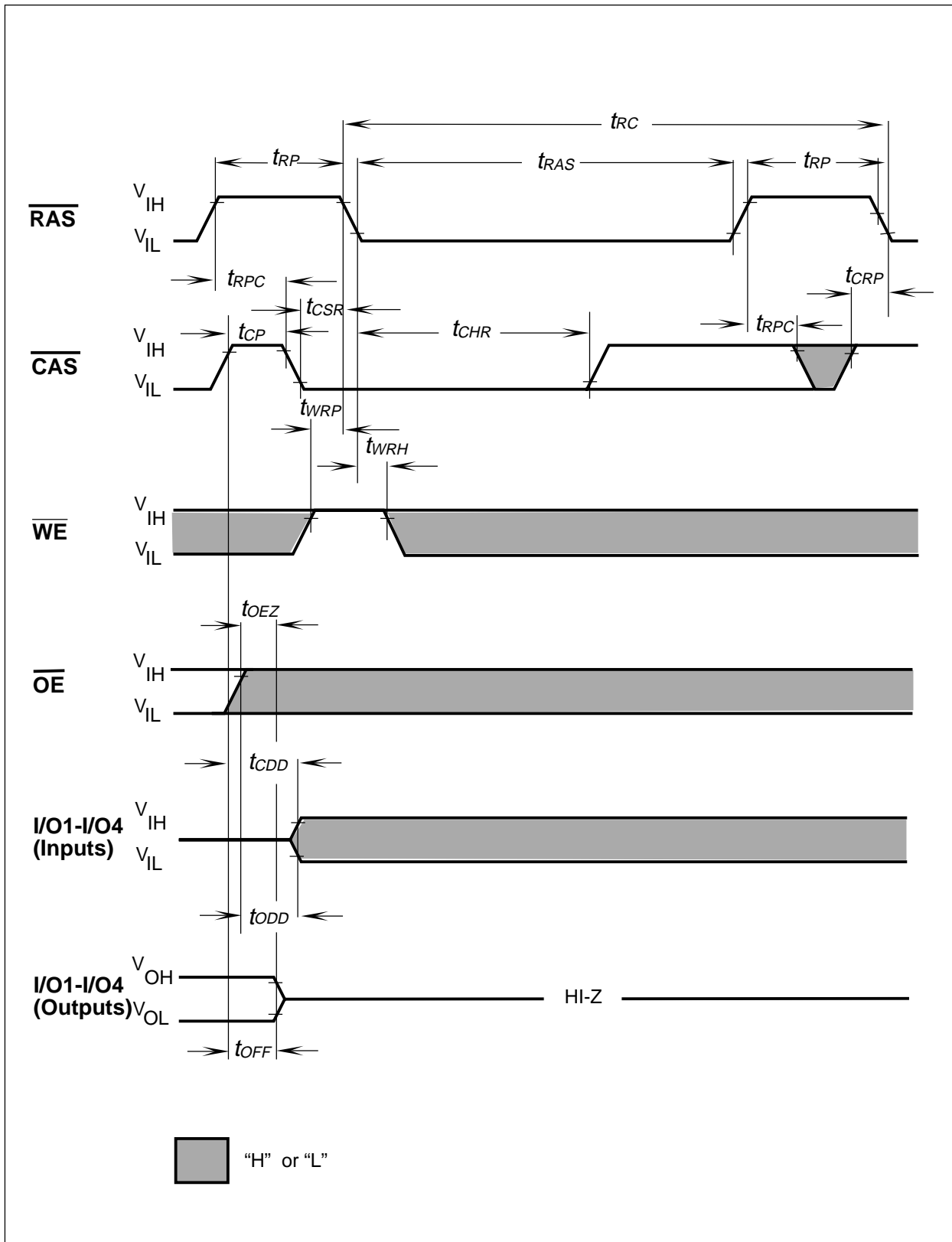

CAS-Before-RAS Refresh Cycle

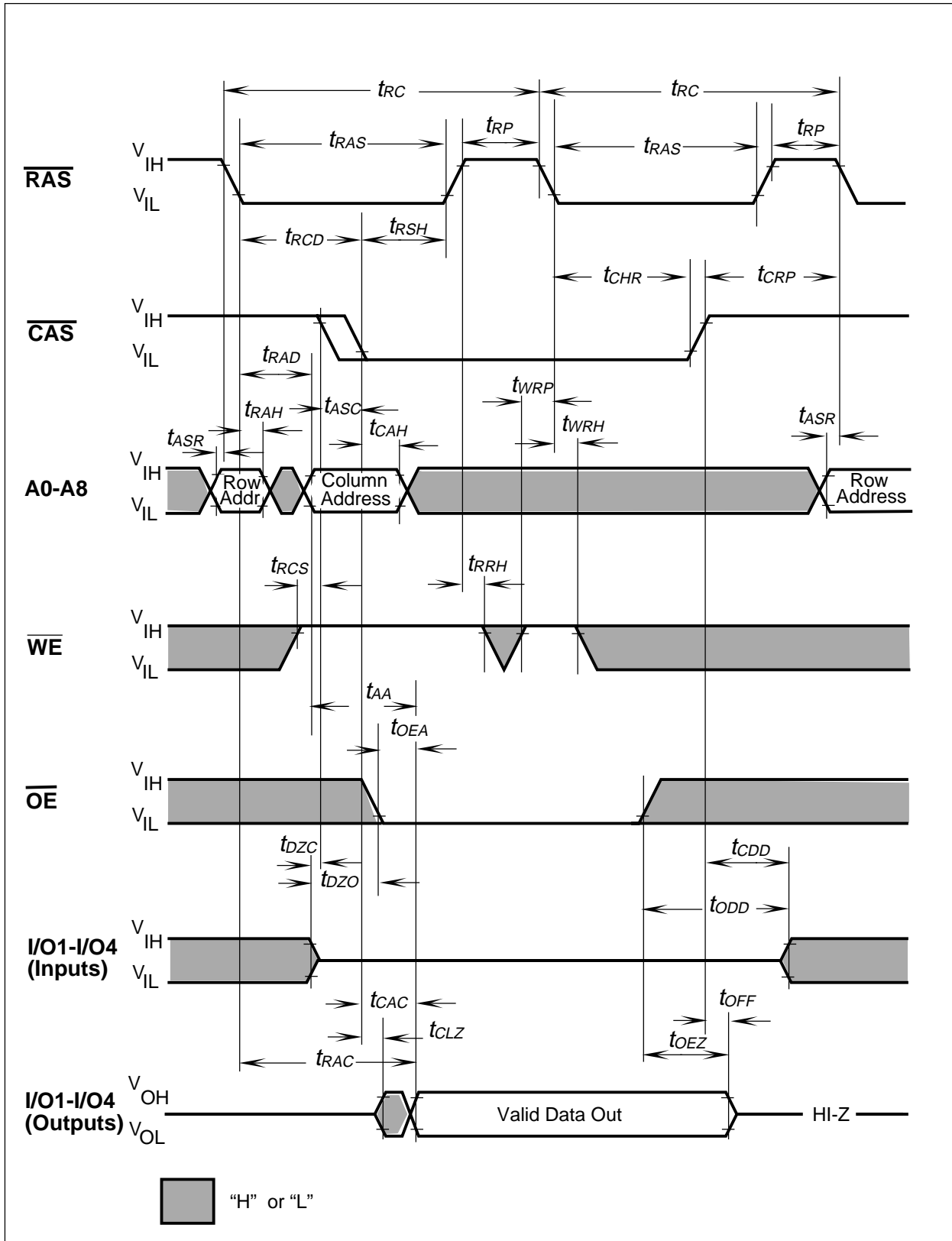

Hidden Refresh Cycle (Read)

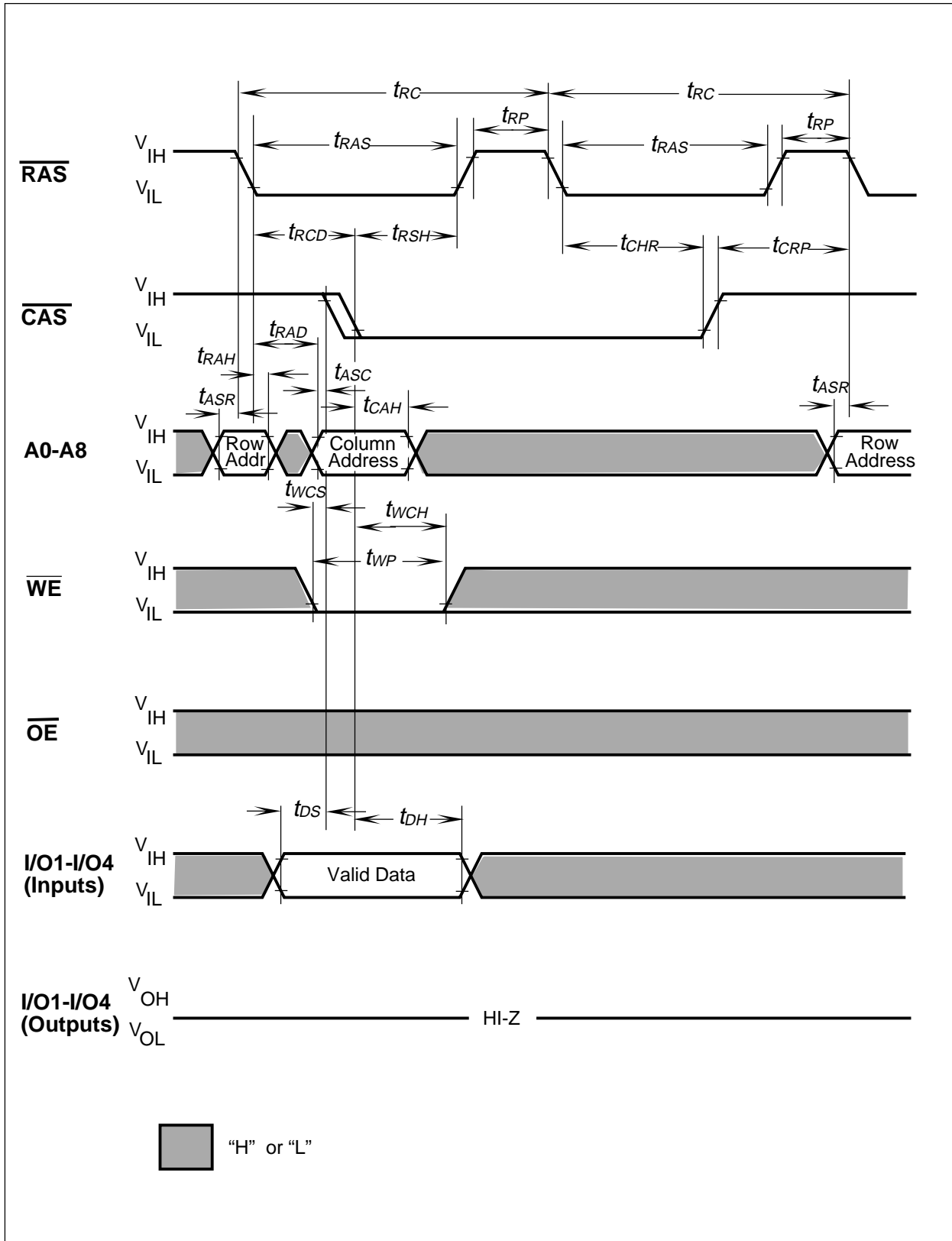

Hidden Refresh Cycle (Early Write)

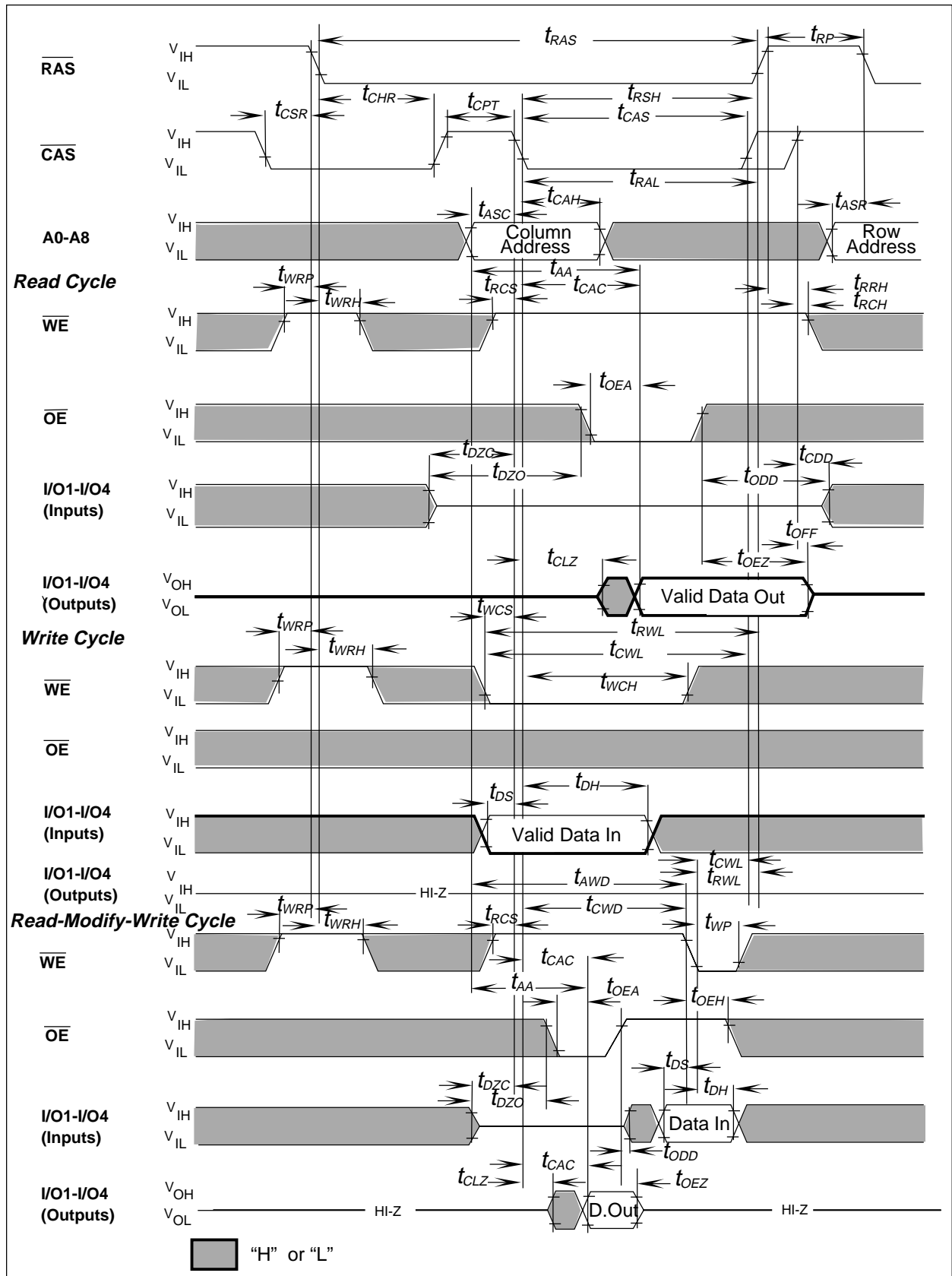



LittleDiode supplies new, hard to find or obsolete electronic components and semiconductors all over the world.

With over two million different components listed you are sure to find the part you need.

Feel free to visit us today at our online store:

LittleDiode.com

Looking forward to providing you with the best possible service.