

## AD7501/AD7502/AD7503

### FEATURES

DTL/TTL/CMOS Direct Interface

Power Dissipation: 30 $\mu$ W

R<sub>ON</sub>: 170 $\Omega$

Standard 16-Pin DIPs and 20-Terminal Surface Mount Packages

### FUNCTIONAL BLOCK DIAGRAMS

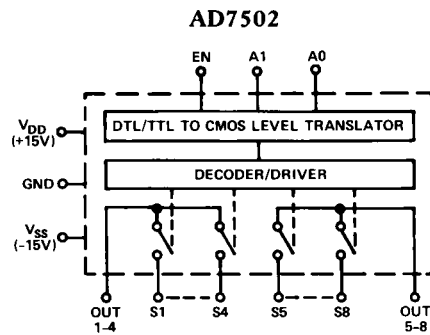
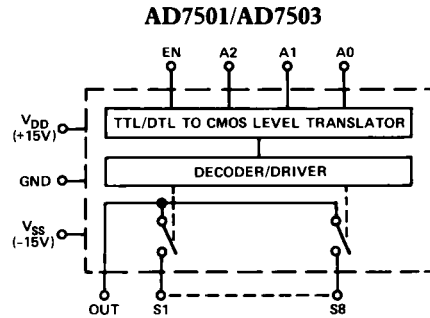

### GENERAL DESCRIPTION

The AD7501 and AD7503 are monolithic CMOS, 8-channel analog multiplexers which switches one of 8 inputs to a common output depending on the state of three binary address lines and an "enable" input. The AD7503 is identical to the AD7501 except its "enable" logic is inverted. All digital inputs are TTL/DTL and CMOS logic compatible.

The AD7502 is a monolithic CMOS dual 4-channel analog multiplexer. Depending on the state of 2 binary address inputs and an "enable", it switches two output buses to two of 8 inputs.

### TRUTH TABLES

AD7501				
A <sub>2</sub>	A <sub>1</sub>	A <sub>0</sub>	E <sub>N</sub>	"ON"
0	0	0	1	1
0	0	1	1	2
0	1	0	1	3
0	1	1	1	4
1	0	0	1	5
1	0	1	1	6
1	1	0	1	7
1	1	1	1	8
X	X	X	0	None

AD7503				
A <sub>2</sub>	A <sub>1</sub>	A <sub>0</sub>	E <sub>N</sub>	"ON"
0	0	0	0	1
0	0	1	0	2
0	1	0	0	3
0	1	1	0	4
1	0	0	0	5
1	0	1	0	6
1	1	0	0	7
1	1	1	0	8
X	X	X	1	None

AD7502			
A <sub>1</sub>	A <sub>0</sub>	E <sub>N</sub>	"ON"
0	0	1	1 & 5
0	1	1	2 & 6
1	0	1	3 & 7
1	1	1	4 & 8
X	X	0	None

### REV. A

Information furnished by Analog Devices is believed to be accurate and reliable. However, no responsibility is assumed by Analog Devices for its use, nor for any infringements of patents or other rights of third parties which may result from its use. No license is granted by implication or otherwise under any patent or patent rights of Analog Devices.

One Technology Way, P.O. Box 9106, Norwood, MA 02062-9106, U.S.A.  
 Tel: 617/329-4700 Fax: 617/326-8703 Twx: 710/394-6577  
 Telex: 924491 Cable: ANALOG NORWOODMASS

# AD7501/AD7502/AD7503—SPECIFICATIONS ( $V_{DD} = +15V$ , $V_{SS} = -15V$ unless otherwise noted.)

PARAMETER	VERSION <sup>1</sup>	SWITCH CONDITION	@25°C		OVER SPECIFIED TEMP. RANGE		TEST CONDITIONS
			AD7501, AD7503	AD7502	AD7501, AD7503	AD7502	
<b>ANALOG SWITCH</b>							
$R_{ON}$	All	ON	170Ω typ, 300Ω max	*			$-10V \leq V_S \leq +10V$ $I_S = 1.0mA$ $V_S = 0V$ , $I_S = 1.0mA$
$R_{ON}$ vs. $V_S$	All	ON	20% typ	*			
$R_{ON}$ vs. Temperature	All	ON	0.5%/°C typ	*			
$\Delta R_{ON}$ Between Switches	All	ON	4% typ	*			
$R_{ON}$ vs. Temperature Between Switches	All	ON	±0.01%/°C	*			
$I_S$	K	OFF	0.2nA typ, 2nA max	*	50nA max	*	$V_S = -10V$ , $V_{OUT} = +10V$ and $V_S = +10V$ , $V_{OUT} = -10V$
	S	OFF	0.5nA max	*	50nA max	*	
$I_{OUT}$	K	OFF	1nA typ, 10nA max	0.6nA typ, 5nA max	250nA max	125nA max	$V_S = -10V$ , $V_{OUT} = +10V$ and $V_S = +10V$ , $V_{OUT} = -10V$ AD7501/02: Enable LOW AD7503: Enable HIGH
	S	OFF	5nA max	3nA max	250nA max	125nA max	
$ I_{OUT} - I_S $	K	ON	12nA max	7nA max	300nA max	175nA max	$V_S = 0$
	S	ON	5.5nA max	3.5nA max	300nA max	175nA max	
<b>DIGITAL CONTROL</b>							
$V_{INL}$	All				0.8V max	*	
$V_{INH}$	All				2.4V min	*	
$I_{INL}$ or $I_{INH}$	All		10nA typ	*			
$C_{IN}$	All		3pF typ	*			
<b>DYNAMIC CHARACTERISTICS</b>							
$t_{ON}$	All		0.8μs typ	*			$V_{IN} = 0$ to +5.0V (See Test Circuit 2)
$t_{OFF}$	All		0.8μs typ	*			
$C_S$	All	OFF	5pF typ	*			
$C_{OUT}$	All	OFF	30pF typ	15pF typ			
$C_{S-OUT}$	All	OFF	0.5pF typ	*			
$C_{SS}$ Between Any Two Switches	All	OFF	0.5pF typ	*			
<b>POWER SUPPLY</b>							
$I_{DD}$	All		500μA max	*	500μA max	*	All Digital Inputs Low
$I_{SS}$	All		500μA max	*	500μA max	*	
$I_{DD}$	All		800μA max	*	800μA max	*	All Digital Inputs High
$I_{SS}$	All		800μA max	*	800μA max	*	

NOTES  
<sup>1</sup>Same specifications as AD7501 and AD7503.  
<sup>1</sup>KN version specified for 0 to +70°C, KQ version for -25°C to +85°C; and SQ, SE versions for -55°C to +125°C.  
 Specifications subject to change without notice.

## ABSOLUTE MAXIMUM RATINGS\*

( $T_A = +25^\circ C$  unless otherwise noted)

$V_{DD}$ to GND	+17V
$V_{SS}$ to GND	-17V
V Between Any Switch Terminals (see Note 1)	25V
Digital Input Voltage Range	$V_{DD}$ to GND
Overvoltage at $V_{OUT}$ ( $V_S$ )	$V_{SS}$ , $V_{DD}$
Switch Current ( $I_S$ , Continuous One Channel)	35mA
Switch Current ( $I_S$ , Surge One Channel)	
1ms Duration, 10% Duty Cycle	50mA
Power Dissipation (Any Package)	
Up to +75°C	450mW
Derates above +75°C by	6mW/°C

## Operating Temperature

Commercial (KN Version)	0 to +70°C
Industrial (KQ Version)	-25°C to +85°C
Extended (SQ, SE Versions)	-55°C to +125°C

Storage Temperature . . . . . -65°C to +150°C

Lead Temperature (Soldering, 10sec) . . . . . +300°C

### CAUTION

- Do not apply voltages higher than  $V_{DD}$  and  $V_{SS}$  to any other terminal, especially when  $V_{SS} = V_{DD} = 0V$  all other pins should be at 0V.
- The digital control inputs are diode protected; however, permanent damage may occur on unconnected units under high energy electrostatic fields. Keep unused units in conductive foam at all times.

## CAUTION:

ESD (electrostatic discharge) sensitive device. The digital control inputs are diode protected; however, permanent damage may occur on unconnected devices subject to high energy electrostatic fields. Unused devices must be stored in conductive foam or shunts. The protective foam should be discharged to the destination socket before devices are inserted.



# AD7501/AD7502/AD7503

## ORDERING GUIDE

Model <sup>1</sup>	Temperature Range	Package Option <sup>2</sup>
AD7501KN	0°C to +70°C	N-16
AD7501KQ	-25°C to +85°C	Q-16
AD7501SQ	-55°C to +125°C	Q-16
AD7501SE	-55°C to +125°C	E-20A
AD7502KN	0°C to +70°C	N-16
AD7502KQ	-25°C to +85°C	Q-16
AD7502SQ	-55°C to +125°C	Q-16
AD7502SE	-55°C to +125°C	E-20A
AD7503KN	0°C to +70°C	N-16
AD7503KQ	-25°C to +85°C	Q-16
AD7503SQ	-55°C to +125°C	Q-16
AD7503SE	-55°C to +125°C	E-20A

### NOTES

<sup>1</sup>To order MIL-STD-883, Class B processed parts, add/883B to part number.

See the Analog Devices' 1990 Military Databook for military data sheet.

<sup>2</sup>E = Leadless Ceramic Chip Carrier; N = Narrow Plastic DIP; Q = Cerdip.

## PIN CONFIGURATIONS

### DIP

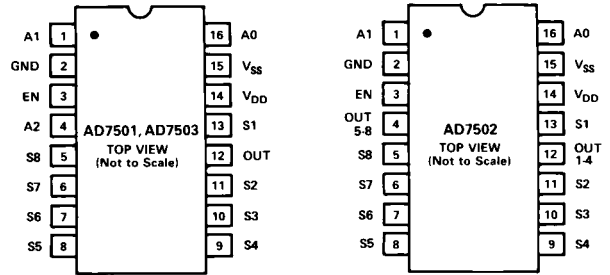

### LCCC

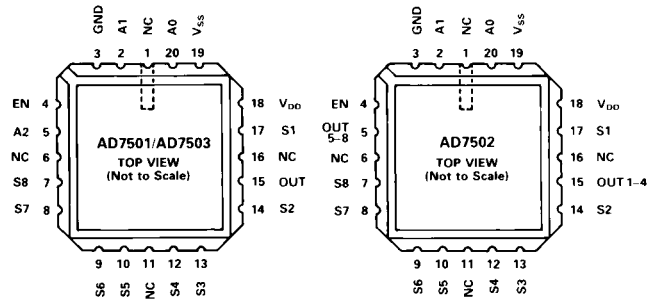

NC = NO CONNECT

## Typical Performance Characteristics

### 1. RON Versus VS

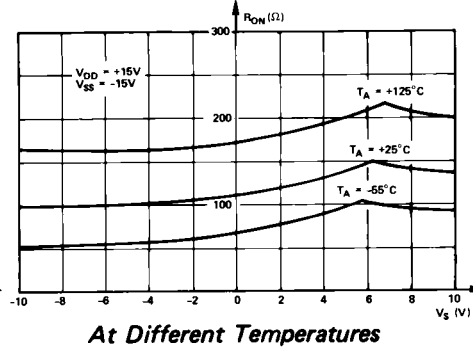
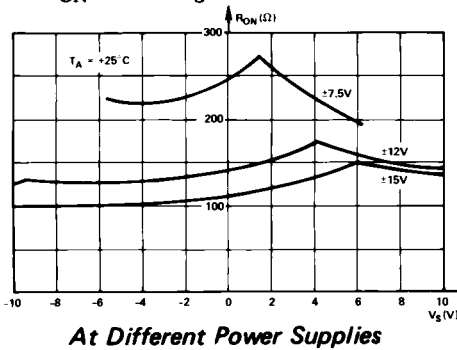

### 2. Digital Threshold Voltage (VINH, VINL)

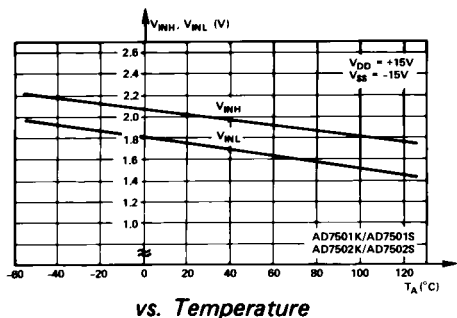
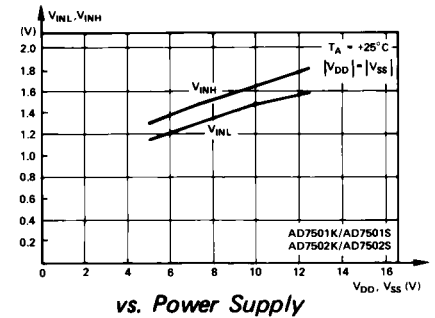

### 3. tON, tOFF

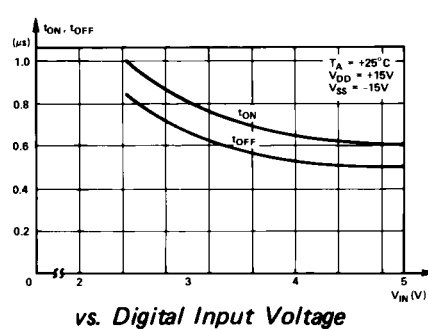

### 4. Power Dissipation

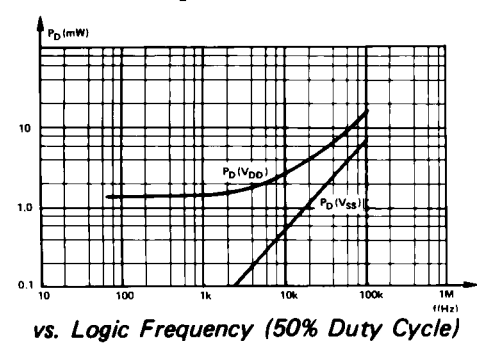

# AD7501/AD7502/AD7503

## TYPICAL SWITCHING CHARACTERISTICS

### TEST CIRCUIT 1

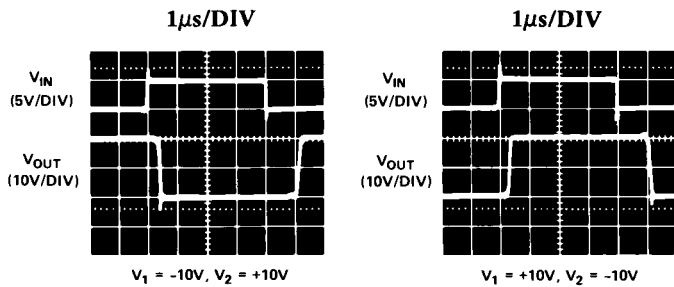
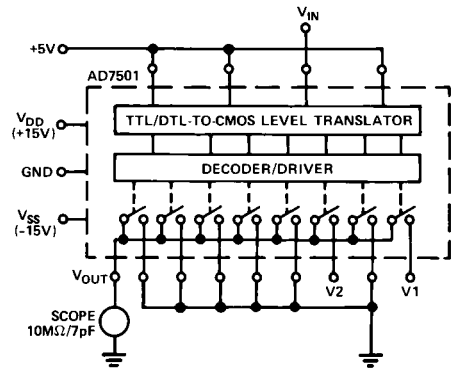

### TEST CIRCUIT 2

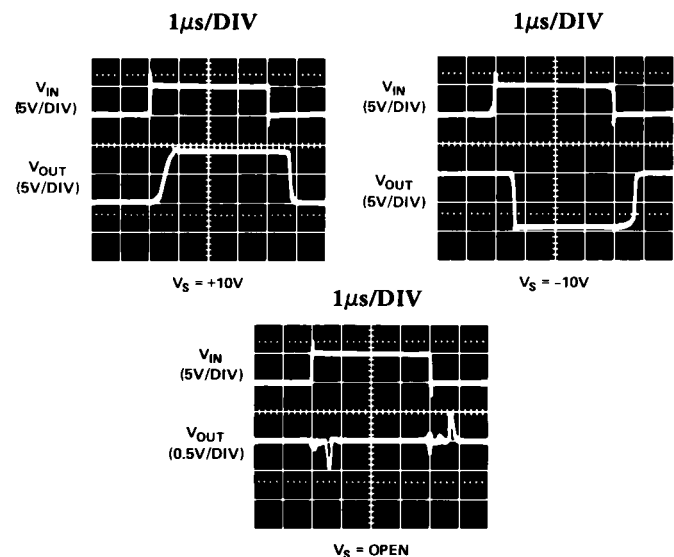
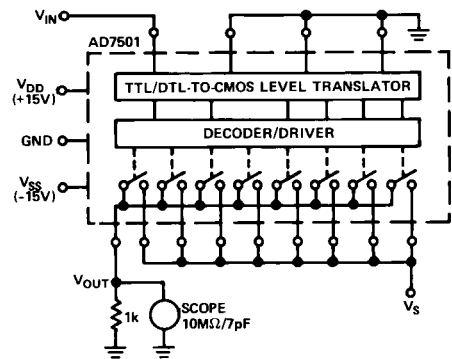

### OUTLINE DIMENSIONS

Dimensions shown in inches and (mm).

#### 16-Pin Plastic DIP (N-16)

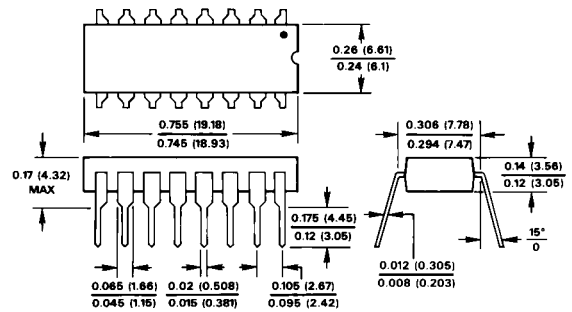

LEAD NO. 1 IDENTIFIED BY DOT OR NOTCH  
LEADS ARE SOLDER OR TIN-PLATED KOVAR OR ALLOY 42

#### 16-Pin Cerdip (Q-16)

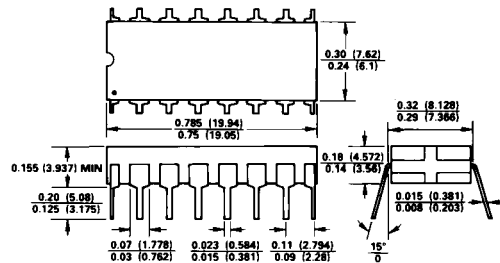

#### 20-Terminal Leadless Ceramic Chip Carrier (E-20A)

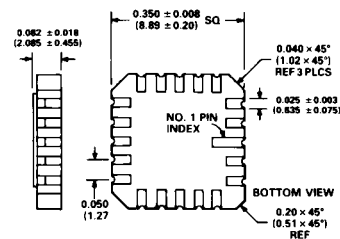



LittleDiode supplies new, hard to find or obsolete electronic components and semiconductors all over the world.

With over two million different components listed you are sure to find the part you need.

Feel free to visit us today at our online store:

[LittleDiode.com](http://LittleDiode.com)

Looking forward to providing you with the best possible service.