

Features

- **Automatic power-down when deselected**
- **CMOS for optimum speed/power**
- **High speed**
— $t_{AA} = 15 \text{ ns}$
- **Low active power**
— 633 mW
- **Low standby power**
— 110 mW
- **TTL-compatible inputs and outputs**
- V_{IH} of 2.2V
- **Capable of withstanding greater than 2001V electrostatic discharge**

Functional Description

The CY7C168A is a high-performance CMOS static RAM organized as 4096 by 4 bits. Easy memory expansion is provided by an active LOW Chip Enable (\overline{CE}) and three-state drivers. The CY7C168A has an automatic power-down feature, reducing the power consumption by 77% when deselected.

Writing to the device is accomplished when the Chip Select (\overline{CE}) and Write Enable (\overline{WE}) inputs are both LOW. Data on the four data input/output pins (I/O_0 through I/O_3) is written into the memory location specified on the address pins (A_0 through A_{11}).

Reading the device is accomplished by taking the Chip Enable (\overline{CE}) LOW, while Write Enable (\overline{WE}) remains HIGH. Under these conditions, the contents of the location specified on the address pins will appear on the four data input/output pins (I/O_0 through I/O_3).

The input/output pins remain in a high-impedance state when Chip Enable (\overline{CE}) is HIGH or Write Enable (\overline{WE}) is LOW.

A die coat is used to insure alpha immunity.

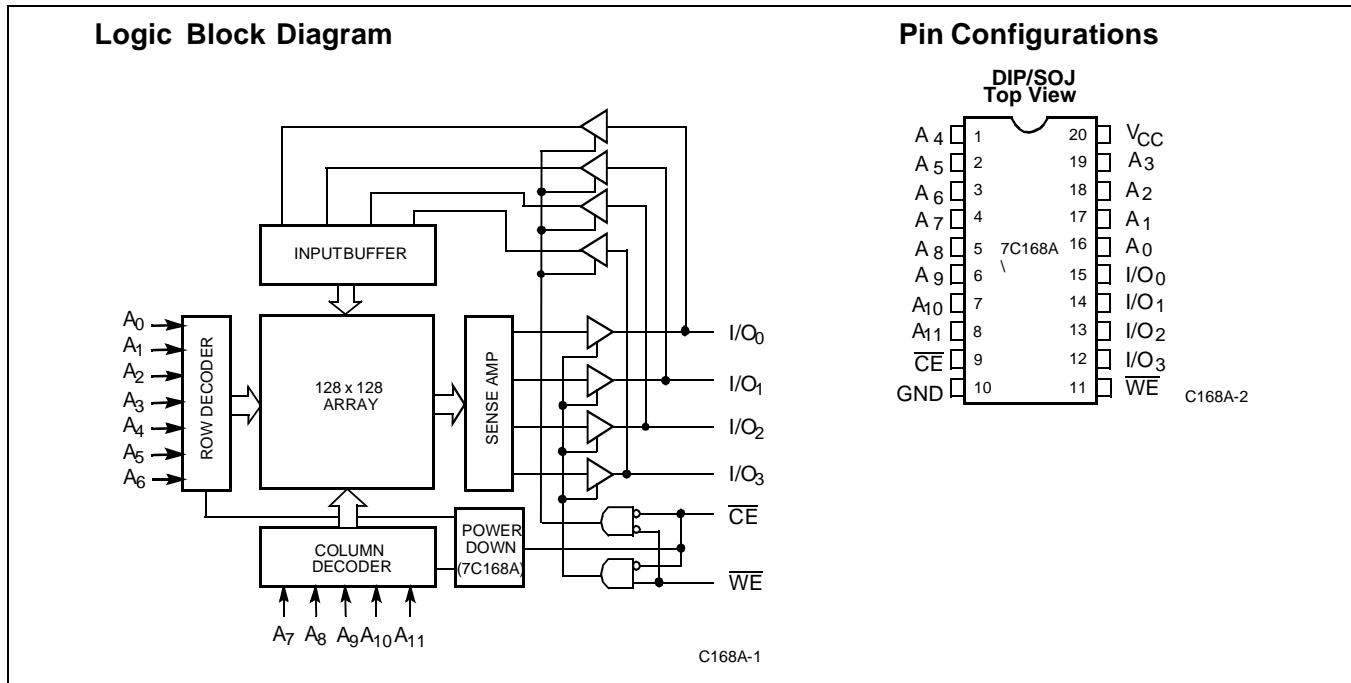
Selection Guide

		7C168A-15	7C168A-20	7C168A-25	7C168A-35	7C168A-45
Maximum Access Time (ns)		15	20	25	35	45
Maximum Operating Current (mA)	Commercial	115	90	90	90	90
	Military	-	100	100	100	100

Maximum Ratings

(Above which the useful life may be impaired. For user guidelines, not tested.)

Storage Temperature -65°C to +150°C
 Ambient Temperature with Power Applied -55°C to +125°C
 Supply Voltage to Ground Potential (Pin 20 to Pin 10) -0.5V to +7.0V
 DC Voltage Applied to Outputs in High Z State -0.5V to +7.0V
 DC Input Voltage -3.0V to +7.0V

Output Current into Outputs (Low) 20 mA
 Static Discharge Voltage >2001V (per MIL-STD-883, Method 3015)
 Latch-Up Current >200 mA

Operating Range

Range	Ambient Temperature	V _{CC}
Commercial	0°C to +70°C	5V ± 10%
Military ^[1]	-55°C to +125°C	5V ± 10%

Electrical Characteristics Over the Operating Range^[2]

Parameter	Description	Test Conditions	7C168A-15		7C168A-20		Unit
			Min.	Max.	Min.	Max.	
V _{OH}	Output HIGH Voltage	V _{CC} = Min., I _{OH} = -4.0 mA	2.4		2.4		V
V _{OL}	Output LOW Voltage	V _{CC} = Min., I _{OL} = 8.0 mA		0.4		0.4	V
V _{IH}	Input HIGH Voltage		2.2	V _{CC}	2.2	V _{CC}	V
V _{IL}	Input LOW Voltage ^[3]		-0.5	0.8	-0.5	0.8	V
I _{IX}	Input Load Current	GND ≤ V _I ≤ V _{CC}	-10	+10	-10	+10	μA
I _{OZ}	Output Leakage Current	GND ≤ V _O ≤ V _{CC} , Output Disabled	-10	+10	-10	+10	μA
I _{OS}	Output Short Circuit Current ^[4]	V _{CC} = Max., V _{OUT} = GND		-350		-350	mA
I _{CC}	V _{CC} Operating Supply Current	V _{CC} = Max., I _{OUT} = 0 mA	Com'l	115		90	mA
			Mil	-		100	
I _{SB1}	Automatic \overline{CE} Power-Down Current	Max. V _{CC} , $\overline{CE} \geq V_{IH}$	Com'l	40		40	mA
			Mil	-		40	
I _{SB2}	Automatic \overline{CE} Power-Down Current	Max. V _{CC} , $\overline{CE} \geq V_{CC} - 0.3V$	Com'l	20		20	mA
			Mil	-		20	

Notes:

1. T_A is the "instant on" case temperature.
2. See the last page of this specification for Group A subgroup testing information.
3. V_{IL} min. = -3.0V for pulse durations less than 30 ns.
4. Not more than 1 output should be shorted at one time. Duration of the short circuit should not exceed 30 seconds.

Electrical Characteristics Over the Operating Range^[2] (continued)

Parameter	Description	Test Conditions	7C168A-25		7C168A-35		7C168A-45		Unit
			Min.	Max.	Min.	Max.	Min.	Max.	
V _{OH}	Output HIGH Voltage	V _{CC} = Min., I _{OH} = -4.0 mA	2.4		2.4		2.4		V
V _{OL}	Output LOW Voltage	V _{CC} = Min., I _{OL} = 8.0 mA		0.4		0.4		0.4	V
V _{IH}	Input HIGH Voltage		2.2	V _{CC}	2.2	V _{CC}	2.2	V _{CC}	V
V _{IL}	Input LOW Voltage ^[3]		-0.5	0.8	-0.5	0.8	-0.5	0.8	V
I _{IX}	Input Load Current	GND ≤ V _I ≤ V _{CC}	-10	+10	-10	10	-10	10	μA
I _{OZ}	Output Leakage Current	GND ≤ V _O ≤ V _{CC} Output Disabled	-10	+10	-50	50	-50	50	μA
I _{OS}	Output Short Circuit Current ^[4]	V _{CC} = Max., V _{OUT} = GND		-350		-350		-350	mA
I _{CC}	V _{CC} Operating Supply Current	V _{CC} = Max., I _{OUT} = 0 mA	Com'l	90		90		90	mA
			Mil		100		100		
I _{SB1}	Automatic \overline{CE} Power-Down Current	Max. V _{CC} , $\overline{CE} \geq V_{IH}$	Com'l	20		20		20	mA
			Mil		20		20		
I _{SB2}	Automatic \overline{CE} Power-Down Current	Max. V _{CC} , $\overline{CE} \geq V_{CC} - 0.3 V$	Com'l	20		20		20	mA
			Mil		20		20		

Capacitance^[5]

Parameter	Description	Test Conditions	Max.	Unit
C _{IN}	Input Capacitance	T _A = 25°C, f = 1 MHz, V _{CC} = 5.0V	10	pF
C _{OUT}	Output Capacitance		10	pF

Note:

5. Tested initially and after any design or process changes that may affect these parameters.

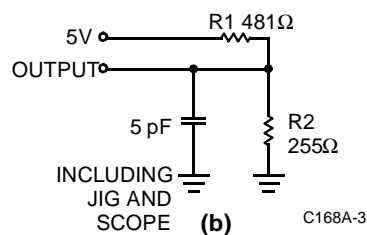
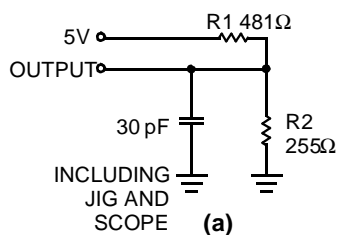
AC Test Loads and Waveforms

C168A-3

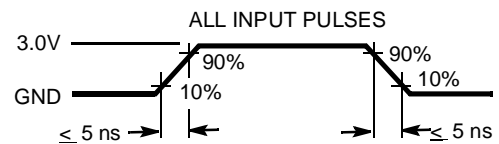

C168A-4

Equivalent to: THÉVENIN EQUIVALENT

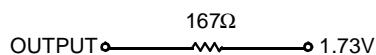

Switching Characteristics Over the Operating Range^[2,6]

Parameter	Description	7C168A-15		7C168A-20		7C168A-25		7C168A-35		7C168A-45		Unit
		Min.	Max.	Min.	Max.	Min.	Max.	Min.	Max.	Min.	Max.	
READ CYCLE												
t _{RC}	Read Cycle Time	15		20		25		35		45		ns
t _{AA}	Address to Data Valid		15		20		25		35		45	ns
t _{OHA}	Output Hold from Address Change	5		5		5		5		5		ns
t _{ACE}	Power Supply Current		15		20		25		35		45	ns
t _{LZCE}	\overline{CE} LOW to Low Z ^[7]	5		5		5		5		5		ns
t _{HZCE}	\overline{CE} HIGH to High Z ^[7, 8]		8		8		10		15		15	ns
t _{PU}	\overline{CE} LOW to Power Up	0		0		0		0		0		ns
t _{PD}	\overline{CE} HIGH to Power-Down		15		20		20		20		25	ns
t _{RCS}	Read Command Set-Up	0		0		0		0		0		ns
t _{RCH}	Read Command Hold	0		0		0		0		0		ns
WRITE CYCLE^[9]												
t _{WC}	Write Cycle Time	15		20		20		25		40		ns
t _{SCE}	\overline{CE} LOW to Write End	12		15		20		25		30		ns
t _{AW}	Address Set-Up to Write End	12		15		20		25		30		ns
t _{HA}	Address Hold from Write End	0		0		0		0		0		ns
t _{SA}	Address Set-Up to Write Start	0		0		0		0		0		ns
t _{PWE}	\overline{WE} Pulse Width	12		15		15		20		20		ns
t _{SD}	Data Set-Up to Write End	10		10		10		15		15		ns
t _{HD}	Data Hold from Write End	0		0		0		0		0		ns
t _{LZWE}	\overline{WE} HIGH to Low Z ^[7]	7		7		7		5		5		ns
t _{HZWE}	\overline{WE} LOW to High Z ^[7, 8]	5		5		5		5		10		ns

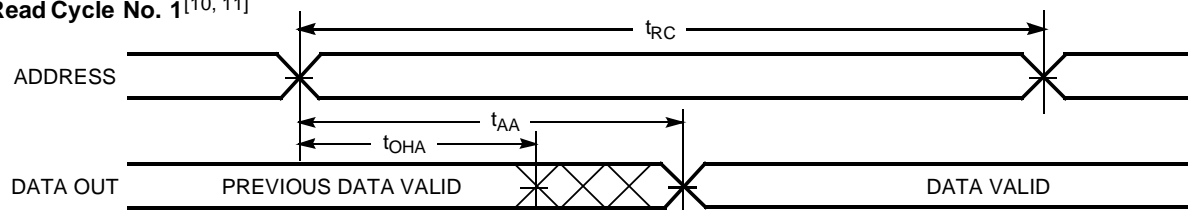
Switching Waveforms
Read Cycle No. 1^[10, 11]

C168A-5

Notes:

6. Test conditions assume signal transition times of 5 ns or less, timing reference levels of 1.5V, input pulse levels of 0 to 3.0V, and output loading of the specified I_{OL}/I_{OH} and 30-pF load capacitance.
7. At any given temperature and voltage condition, t_{HZ} is less than t_{LZ} for all devices. Transition is measured ±500 mV from steady state voltage with specified loading in part (b) of AC Test Loads and Waveforms.
8. t_{HZCE} and t_{HZWE} are tested with C_L = 5 pF as in part (a) of Test Loads and Waveforms. Transition is measured ±500 mV from steady state voltage.
9. The internal write time of the memory is defined by the overlap of \overline{CE} LOW and \overline{WE} LOW. Both signal must be LOW to initiate a write and either signal can terminate a write by going high. The data input set-up and hold timing should be referenced to the rising edge of the signal that terminates the write.
10. \overline{WE} is HIGH for read cycle.
11. Device is continuously selected, $\overline{CE} = V_{IL}$.

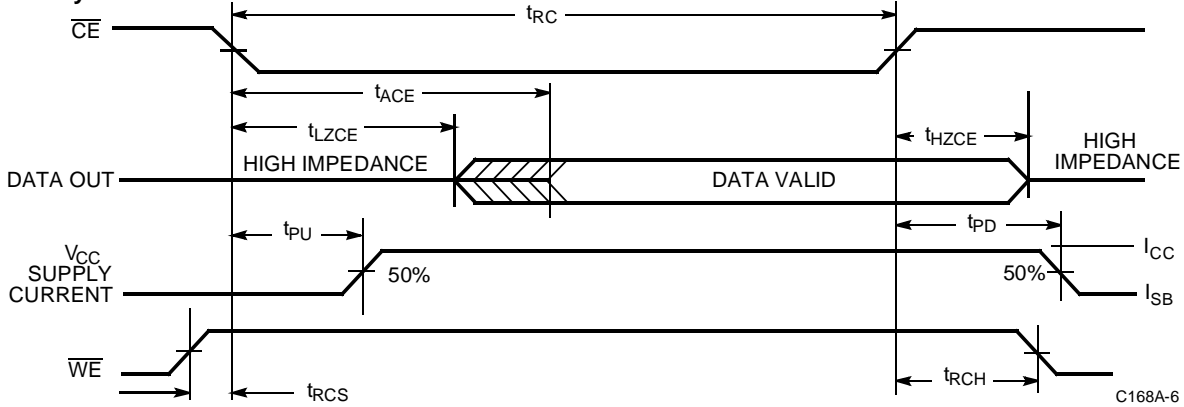
Switching Waveforms (continued)
Read Cycle ^[10, 12]

C168A-6

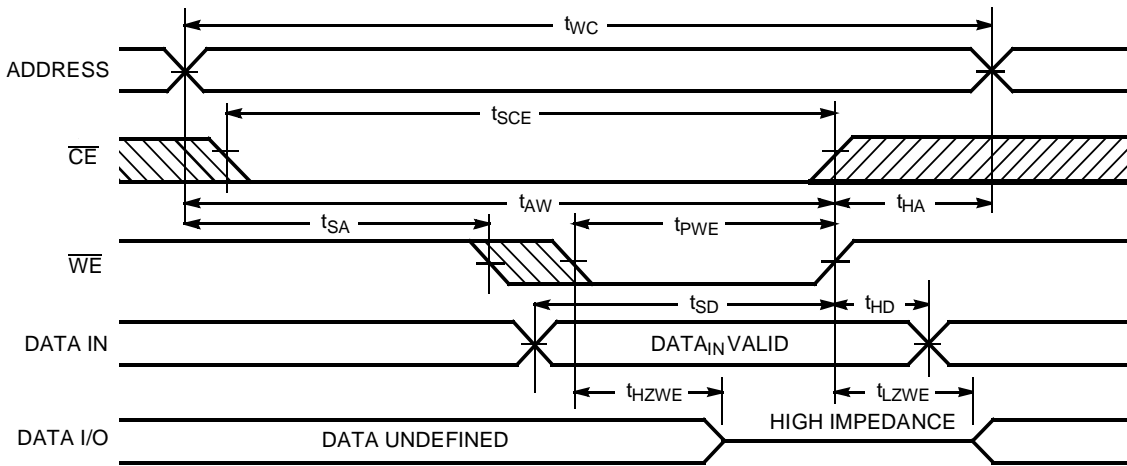
Write Cycle No. 1 (\overline{WE} Controlled) ^[9]

C168A-7

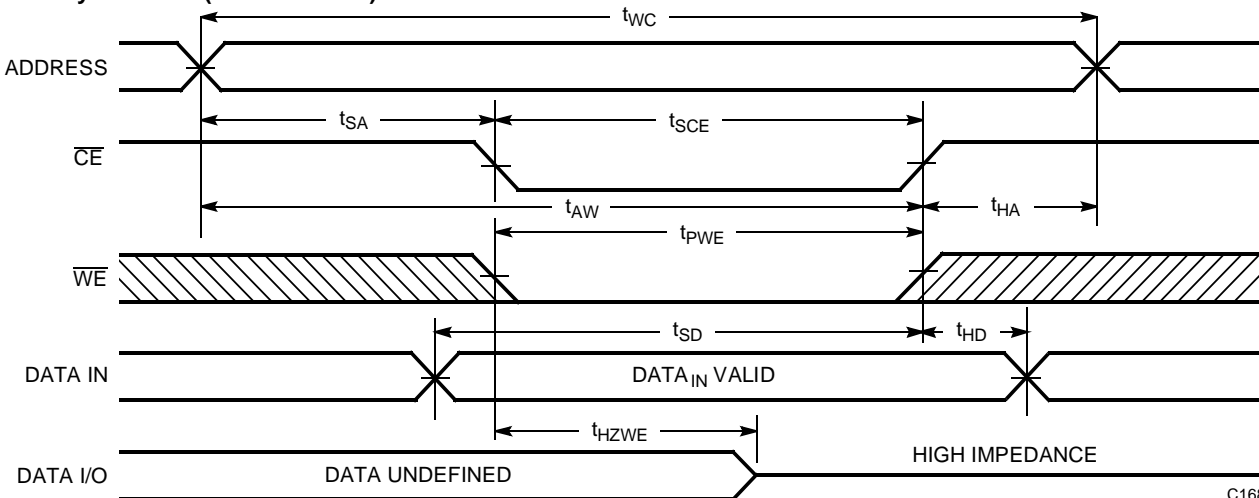
Write Cycle No. 2 (\overline{CS} Controlled) ^[9, 13]

C168A-8

Notes:

12. Address valid prior to or coincident with \overline{CE} transition LOW.
13. If \overline{CE} goes HIGH simultaneously with \overline{WE} HIGH, the output remains in a high-impedance state.

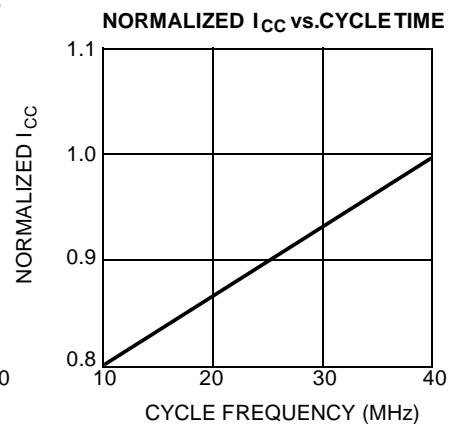
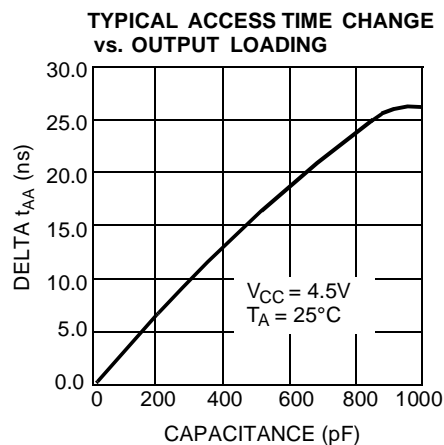
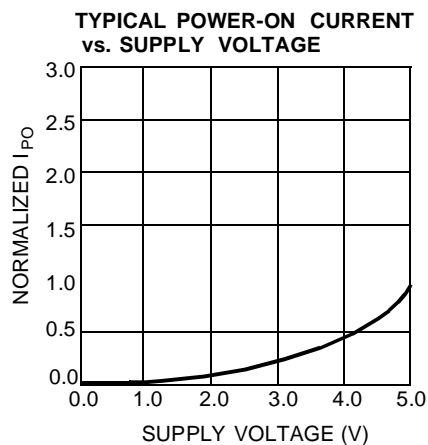
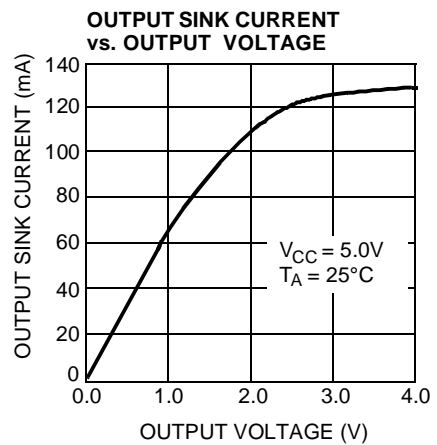
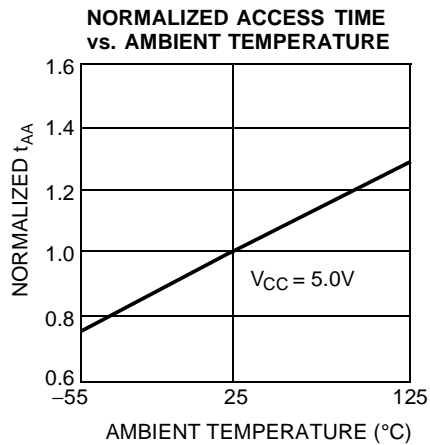
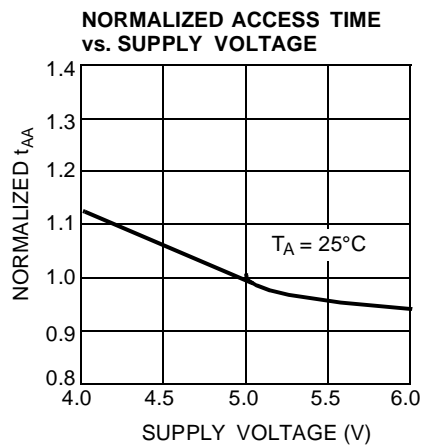
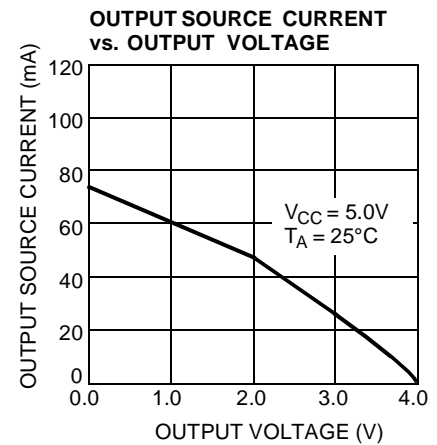
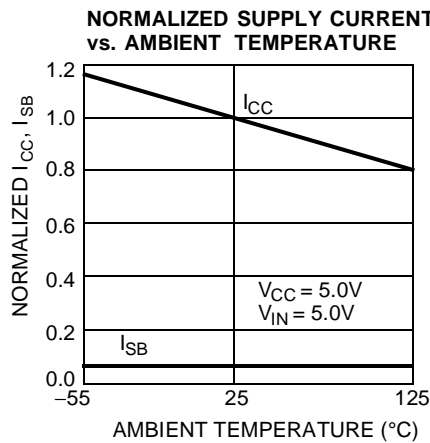
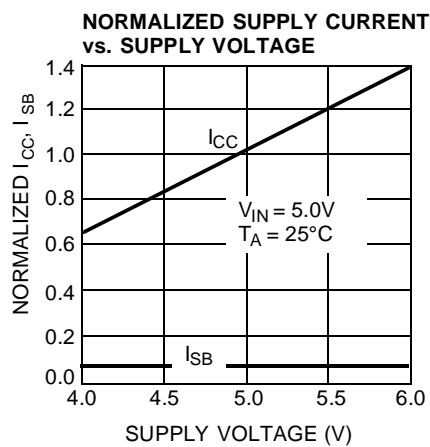
Typical DC and AC Characteristics

Ordering Information

Speed (ns)	I _{CC} (mA)	Ordering Code	Package Name	Package Type	Operating Range
15	115	CY7C168A-15PC	P5	20-Lead (300-Mil) Molded DIP	Commercial
		CY7C168A-15VC	V5	20-Lead Molded SOJ	
20	90	CY7C168A-20PC	P5	20-Lead (300-Mil) Molded DIP	Commercial
		CY7C168A-20VC	V5	20-Lead Molded SOJ	
		CY7C168A-20DMB	D6	20-Lead (300-Mil) CerDIP	Military
25	70	CY7C168A-25PC	P5	20-Lead (300-Mil) Molded DIP	Commercial
		CY7C168A-25VC	V5	20-Lead Molded SOJ	
	80	CY7C168A-25DMB	D6	20-Lead (300-Mil) CerDIP	Military
35	70	CY7C168A-35PC	P5	20-Lead (300-Mil) Molded DIP	Commercial
		CY7C168A-35VC	V5	20-Lead Molded SOJ	
		CY7C168A-35DMB	D6	20-Lead (300-Mil) CerDIP	Military
45	70	CY7C168A-45PC	P5	20-Lead (300-Mil) Molded DIP	Commercial
		CY7C168A-45VC	V5	20-Lead Molded SOJ	
		CY7C168A-45DMB	D6	20-Lead (300-Mil) CerDIP	Military

MILITARY SPECIFICATIONS
Group A Subgroup Testing
DC Characteristics

Parameter	Subgroups
V _{OH}	1, 2, 3
V _{OL}	1, 2, 3
V _{IH}	1, 2, 3
V _{IL Max.}	1, 2, 3
I _{IX}	1, 2, 3
I _{OZ}	1, 2, 3
I _{CC}	1, 2, 3
I _{SB1}	1, 2, 3
I _{SB2}	1, 2, 3

Document #: 38-00095-E

Switching Characteristics

Parameter	Subgroups
READ CYCLE	
t _{RC}	7, 8, 9, 10, 11
t _{AA}	7, 8, 9, 10, 11
t _{OHA}	7, 8, 9, 10, 11
t _{ACE}	7, 8, 9, 10, 11
t _{RCS}	7, 8, 9, 10, 11
t _{RCH}	7, 8, 9, 10, 11
WRITE CYCLE	
t _{WC}	7, 8, 9, 10, 11
t _{SCE}	7, 8, 9, 10, 11
t _{AW}	7, 8, 9, 10, 11
t _{HA}	7, 8, 9, 10, 11
t _{SA}	7, 8, 9, 10, 11
t _{PWE}	7, 8, 9, 10, 11
t _{SD}	7, 8, 9, 10, 11
t _{HD}	7, 8, 9, 10, 11

Package Diagrams

20-Lead (300-Mil) CerDIP D6
MIL-STD-1835 D-8 Config. A

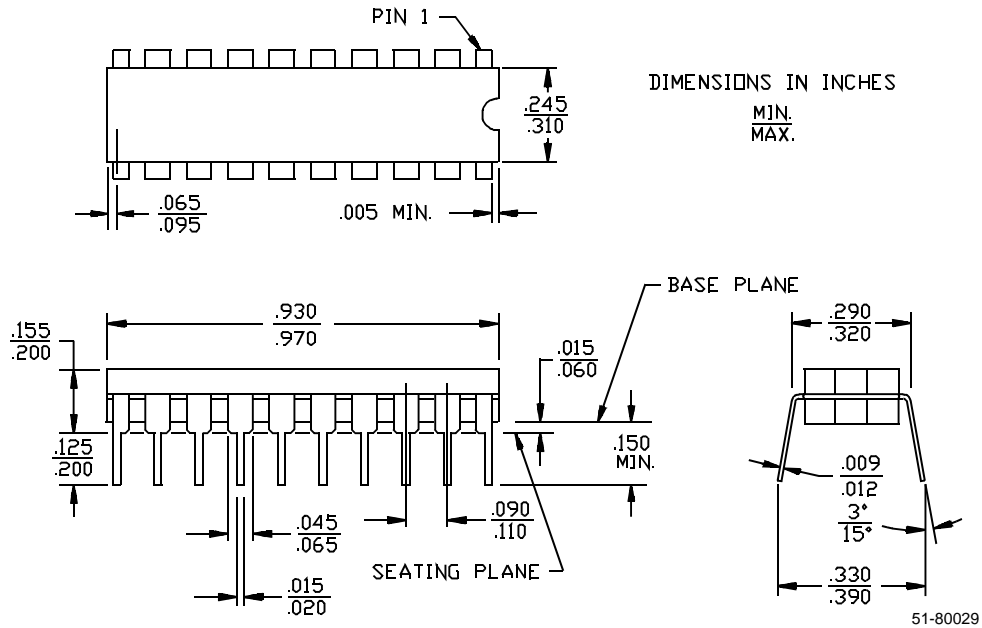

20-Lead (300-Mil) Molded DIP P5

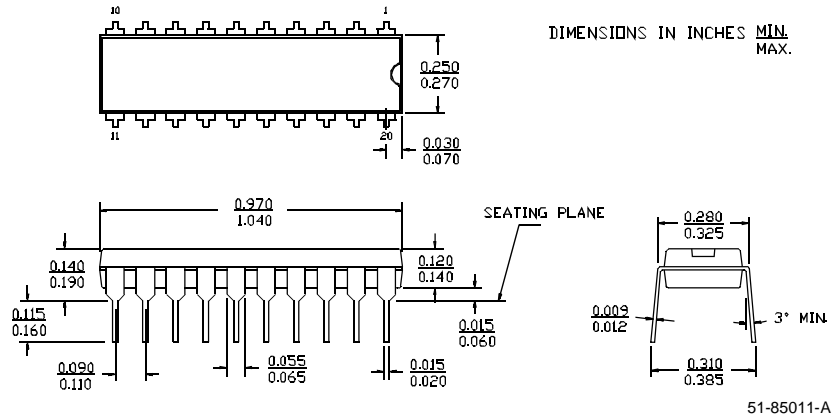

Package Diagrams (continued)

20-Lead (300-Mil) Molded SOJ V5

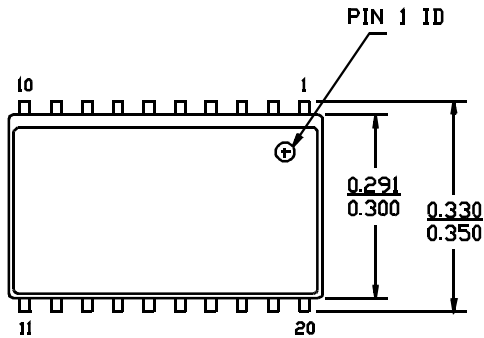

DIMENSIONS IN INCHES MIN.
MAX.

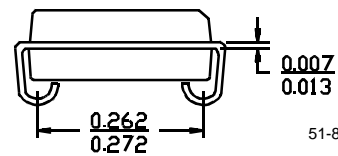
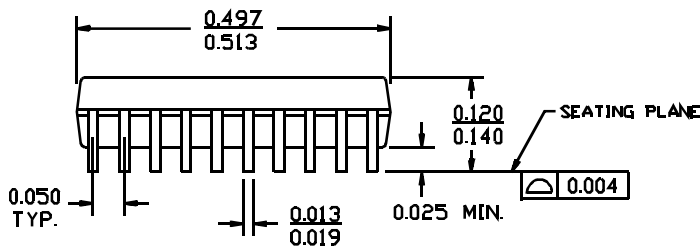

51-85029-A



LittleDiode supplies new, hard to find or obsolete electronic components and semiconductors all over the world.

With over two million different components listed you are sure to find the part you need.

Feel free to visit us today at our online store:

LittleDiode.com

Looking forward to providing you with the best possible service.