

FEATURES

EASY TO USE

Gain Set with One External Resistor
(Gain Range 1 to 1000)

Wide Power Supply Range (± 2.3 V to ± 18 V)
Higher Performance than Three Op Amp IA Designs
Available in 8-Lead DIP and SOIC Packaging
Low Power, 1.3 mA max Supply Current

EXCELLENT DC PERFORMANCE ("B GRADE")

50 μ V max, Input Offset Voltage
0.6 μ V/ $^{\circ}$ C max, Input Offset Drift
1.0 nA max, Input Bias Current
100 dB min Common-Mode Rejection Ratio (G = 10)

LOW NOISE

9 nV/ $\sqrt{\text{Hz}}$, @ 1 kHz, Input Voltage Noise
0.28 μ V p-p Noise (0.1 Hz to 10 Hz)

EXCELLENT AC SPECIFICATIONS

120 kHz Bandwidth (G = 100)
15 μ s Settling Time to 0.01%

APPLICATIONS

Weigh Scales
ECG and Medical Instrumentation
Transducer Interface
Data Acquisition Systems
Industrial Process Controls
Battery Powered and Portable Equipment

PRODUCT DESCRIPTION

The AD620 is a low cost, high accuracy instrumentation amplifier that requires only one external resistor to set gains of 1 to

CONNECTION DIAGRAM

8-Lead Plastic Mini-DIP (N), Cerdip (Q)
and SOIC (R) Packages

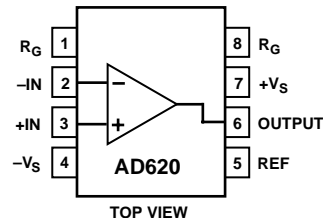

1000. Furthermore, the AD620 features 8-lead SOIC and DIP packaging that is smaller than discrete designs, and offers lower power (only 1.3 mA max supply current), making it a good fit for battery powered, portable (or remote) applications.

The AD620, with its high accuracy of 40 ppm maximum nonlinearity, low offset voltage of 50 μ V max and offset drift of 0.6 μ V/ $^{\circ}$ C max, is ideal for use in precision data acquisition systems, such as weigh scales and transducer interfaces. Furthermore, the low noise, low input bias current, and low power of the AD620 make it well suited for medical applications such as ECG and noninvasive blood pressure monitors.

The low input bias current of 1.0 nA max is made possible with the use of Super β processing in the input stage. The AD620 works well as a preamplifier due to its low input voltage noise of 9 nV/ $\sqrt{\text{Hz}}$ at 1 kHz, 0.28 μ V p-p in the 0.1 Hz to 10 Hz band, 0.1 pA/ $\sqrt{\text{Hz}}$ input current noise. Also, the AD620 is well suited for multiplexed applications with its settling time of 15 μ s to 0.01% and its cost is low enough to enable designs with one in-amp per channel.

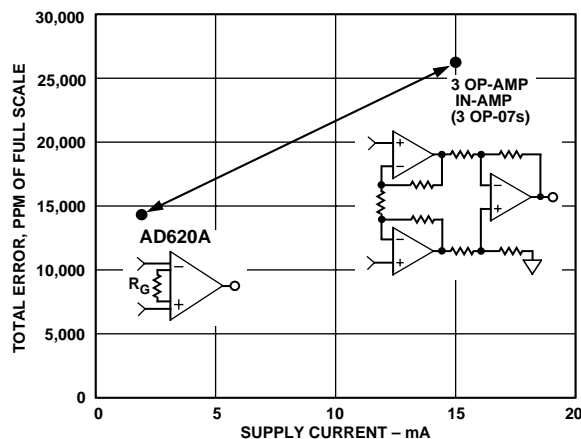

Figure 1. Three Op Amp IA Designs vs. AD620

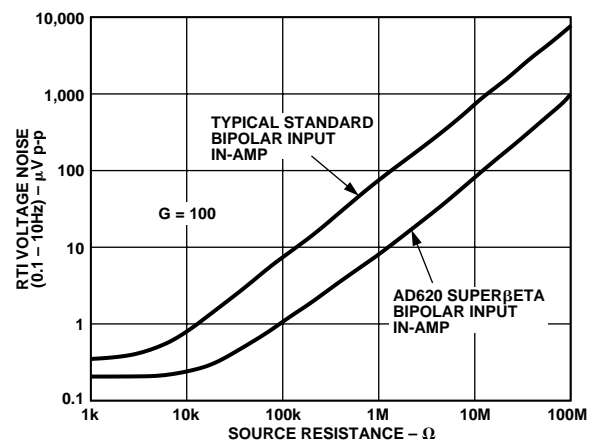

Figure 2. Total Voltage Noise vs. Source Resistance

REV. E

Information furnished by Analog Devices is believed to be accurate and reliable. However, no responsibility is assumed by Analog Devices for its use, nor for any infringements of patents or other rights of third parties which may result from its use. No license is granted by implication or otherwise under any patent or patent rights of Analog Devices.

AD620—SPECIFICATIONS

(Typical @ +25°C, $V_S = \pm 15\text{ V}$, and $R_L = 2\text{ k}\Omega$, unless otherwise noted)

Model	Conditions	AD620A			AD620B			AD620S ¹			Units
		Min	Typ	Max	Min	Typ	Max	Min	Typ	Max	
GAIN	$G = 1 + (49.4\text{ k}/R_G)$										
Gain Range		1		10,000	1		10,000	1		10,000	
Gain Error ²	$V_{OUT} = \pm 10\text{ V}$										
G = 1			0.03	0.10		0.01	0.02		0.03	0.10	%
G = 10			0.15	0.30		0.10	0.15		0.15	0.30	%
G = 100			0.15	0.30		0.10	0.15		0.15	0.30	%
G = 1000			0.40	0.70		0.35	0.50		0.40	0.70	%
Nonlinearity,	$V_{OUT} = -10\text{ V to } +10\text{ V}$,										
G = 1–1000	$R_L = 10\text{ k}\Omega$		10	40		10	40		10	40	ppm
G = 1–100	$R_L = 2\text{ k}\Omega$		10	95		10	95		10	95	ppm
Gain vs. Temperature	G = 1			10			10			10	ppm/°C
	Gain > 1 ²			–50			–50			–50	ppm/°C
VOLTAGE OFFSET	(Total RTI Error = $V_{OSI} + V_{OSO}/G$)										
Input Offset, V_{OSI}	$V_S = \pm 5\text{ V to } \pm 15\text{ V}$		30	125		15	50		30	125	μV
Over Temperature	$V_S = \pm 5\text{ V to } \pm 15\text{ V}$			185			85			225	μV
Average TC	$V_S = \pm 5\text{ V to } \pm 15\text{ V}$		0.3	1.0		0.1	0.6		0.3	1.0	$\mu\text{V}/^\circ\text{C}$
Output Offset, V_{OSO}	$V_S = \pm 15\text{ V}$		400	1000		200	500		400	1000	μV
Over Temperature	$V_S = \pm 5\text{ V}$			1500			750			1500	μV
Average TC	$V_S = \pm 5\text{ V to } \pm 15\text{ V}$		5.0	15		2.5	7.0		5.0	15	$\mu\text{V}/^\circ\text{C}$
Offset Referred to the Input vs. Supply (PSR)	$V_S = \pm 2.3\text{ V to } \pm 18\text{ V}$										
G = 1		80		100	80		100	80		100	dB
G = 10		95		120	100		120	95		120	dB
G = 100		110		140	120		140	110		140	dB
G = 1000		110		140	120		140	110		140	dB
INPUT CURRENT											
Input Bias Current			0.5	2.0		0.5	1.0		0.5	2	nA
Over Temperature				2.5			1.5			4	nA
Average TC			3.0			3.0			8.0		$\text{pA}/^\circ\text{C}$
Input Offset Current			0.3	1.0		0.3	0.5		0.3	1.0	nA
Over Temperature				1.5			0.75			2.0	nA
Average TC			1.5			1.5			8.0		$\text{pA}/^\circ\text{C}$
INPUT											
Input Impedance											
Differential			10	2		10	2		10	2	$\text{G}\Omega \parallel \text{pF}$
Common-Mode			10	2		10	2		10	2	$\text{G}\Omega \parallel \text{pF}$
Input Voltage Range ³	$V_S = \pm 2.3\text{ V to } \pm 5\text{ V}$	$-V_S + 1.9$		$+V_S - 1.2$	$-V_S + 1.9$		$+V_S - 1.2$	$-V_S + 1.9$		$+V_S - 1.2$	V
Over Temperature		$-V_S + 2.1$		$+V_S - 1.3$	$-V_S + 2.1$		$+V_S - 1.3$	$-V_S + 2.1$		$+V_S - 1.3$	V
Over Temperature	$V_S = \pm 5\text{ V to } \pm 18\text{ V}$	$-V_S + 1.9$		$+V_S - 1.4$	$-V_S + 1.9$		$+V_S - 1.4$	$-V_S + 1.9$		$+V_S - 1.4$	V
Over Temperature		$-V_S + 2.1$		$+V_S - 1.4$	$-V_S + 2.1$		$+V_S - 1.4$	$-V_S + 2.3$		$+V_S - 1.4$	V
Common-Mode Rejection Ratio DC to 60 Hz with 1 k Ω Source Imbalance	$V_{CM} = 0\text{ V to } \pm 10\text{ V}$										
G = 1		73		90	80		90	73		90	dB
G = 10		93		110	100		110	93		110	dB
G = 100		110		130	120		130	110		130	dB
G = 1000		110		130	120		130	110		130	dB
OUTPUT											
Output Swing	$R_L = 10\text{ k}\Omega$,										
Over Temperature	$V_S = \pm 2.3\text{ V to } \pm 5\text{ V}$	$-V_S + 1.1$		$+V_S - 1.2$	$-V_S + 1.1$		$+V_S - 1.2$	$-V_S + 1.1$		$+V_S - 1.2$	V
Over Temperature		$-V_S + 1.4$		$+V_S - 1.3$	$-V_S + 1.4$		$+V_S - 1.3$	$-V_S + 1.6$		$+V_S - 1.3$	V
Over Temperature	$V_S = \pm 5\text{ V to } \pm 18\text{ V}$	$-V_S + 1.2$		$+V_S - 1.4$	$-V_S + 1.2$		$+V_S - 1.4$	$-V_S + 1.2$		$+V_S - 1.4$	V
Over Temperature		$-V_S + 1.6$		$+V_S - 1.5$	$-V_S + 1.6$		$+V_S - 1.5$	$-V_S + 2.3$		$+V_S - 1.5$	V
Short Current Circuit			± 18			± 18			± 18		mA

Model	Conditions	AD620A			AD620B			AD620S ¹			Units	
		Min	Typ	Max	Min	Typ	Max	Min	Typ	Max		
DYNAMIC RESPONSE												
Small Signal -3 dB Bandwidth	10 V Step											
G = 1			1000			1000			1000		kHz	
G = 10			800			800			800		kHz	
G = 100			120			120			120		kHz	
G = 1000			12			12			12		kHz	
Slew Rate			0.75	1.2		0.75	1.2		0.75	1.2	V/μs	
Settling Time to 0.01%												
G = 1-100			15			15			15	μs		
G = 1000			150			150			150	μs		
NOISE												
Voltage Noise, 1 kHz	f = 1 kHz	$Total\ RTI\ Noise = \sqrt{(e_{ni}^2) + (e_{no}/G)^2}$										
Input, Voltage Noise, e_{ni}			9	13		9	13		9	13	nV/√Hz	
Output, Voltage Noise, e_{no}			72	100		72	100		72	100	nV/√Hz	
RTI, 0.1 Hz to 10 Hz												
G = 1				3.0			3.0	6.0		3.0	6.0	μV p-p
G = 10				0.55			0.55	0.8		0.55	0.8	μV p-p
G = 100-1000			0.28			0.28	0.4		0.28	0.4	μV p-p	
Current Noise			100			100			100	fA/√Hz		
0.1 Hz to 10 Hz			10			10			10	pA p-p		
REFERENCE INPUT												
R_{IN}	$V_{IN+}, V_{REF} = 0$		20			20			20		kΩ	
I_{IN}			+50	+60		+50	+60		+50	+60	μA	
Voltage Range			- $V_S + 1.6$		+ $V_S - 1.6$	- $V_S + 1.6$		+ $V_S - 1.6$	- $V_S + 1.6$		+ $V_S - 1.6$	V
Gain to Output				1 ± 0.0001			1 ± 0.0001			1 ± 0.0001		
POWER SUPPLY												
Operating Range ⁴	$V_S = \pm 2.3\text{ V to } \pm 18\text{ V}$		±2.3			±2.3			±2.3		V	
Quiescent Current				0.9	1.3		0.9	1.3		0.9	1.3	mA
Over Temperature				1.1	1.6		1.1	1.6		1.1	1.6	mA
TEMPERATURE RANGE												
For Specified Performance			-40 to +85			-40 to +85			-55 to +125		°C	

NOTES

¹See Analog Devices military data sheet for 883B tested specifications.²Does not include effects of external resistor R_G .³One input grounded. G = 1.⁴This is defined as the same supply range which is used to specify PSR.

Specifications subject to change without notice.

AD620

ABSOLUTE MAXIMUM RATINGS¹

Supply Voltage	±18 V
Internal Power Dissipation ²	650 mW
Input Voltage (Common Mode)	±V _S
Differential Input Voltage	±25 V
Output Short Circuit Duration	Indefinite
Storage Temperature Range (Q)	-65°C to +150°C
Storage Temperature Range (N, R)	-65°C to +125°C
Operating Temperature Range	
AD620 (A, B)	-40°C to +85°C
AD620 (S)	-55°C to +125°C
Lead Temperature Range	
(Soldering 10 seconds)	+300°C

NOTES

¹Stresses above those listed under Absolute Maximum Ratings may cause permanent damage to the device. This is a stress rating only; functional operation of the device at these or any other conditions above those indicated in the operational section of this specification is not implied. Exposure to absolute maximum rating conditions for extended periods may affect device reliability.

²Specification is for device in free air:

8-Lead Plastic Package: $\theta_{JA} = 95^{\circ}\text{C}/\text{W}$

8-Lead Cerdip Package: $\theta_{JA} = 110^{\circ}\text{C}/\text{W}$

8-Lead SOIC Package: $\theta_{JA} = 155^{\circ}\text{C}/\text{W}$

ORDERING GUIDE

Model	Temperature Ranges	Package Options*
AD620AN	-40°C to +85°C	N-8
AD620BN	-40°C to +85°C	N-8
AD620AR	-40°C to +85°C	SO-8
AD620AR-REEL	-40°C to +85°C	13" REEL
AD620AR-REEL7	-40°C to +85°C	7" REEL
AD620BR	-40°C to +85°C	SO-8
AD620BR-REEL	-40°C to +85°C	13" REEL
AD620BR-REEL7	-40°C to +85°C	7" REEL
AD620ACHIPS	-40°C to +85°C	Die Form
AD620SQ/883B	-55°C to +125°C	Q-8

*N = Plastic DIP; Q = Cerdip; SO = Small Outline.

METALIZATION PHOTOGRAPH

Dimensions shown in inches and (mm).

Contact factory for latest dimensions.

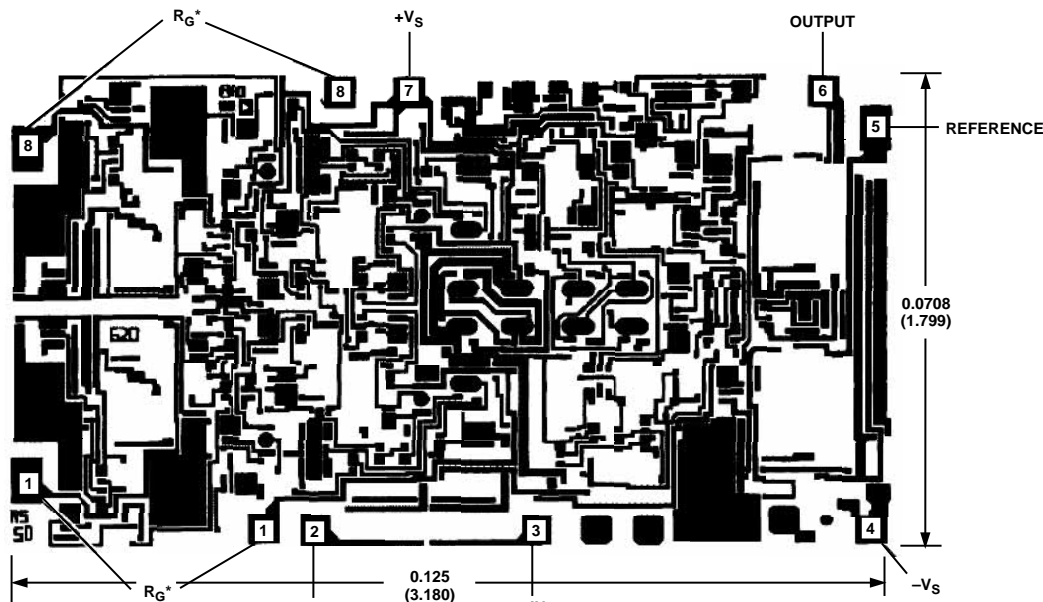

*FOR CHIP APPLICATIONS: THE PADS 1R_G AND 8R_G MUST BE CONNECTED IN PARALLEL TO THE EXTERNAL GAIN REGISTER R_G. DO NOT CONNECT THEM IN SERIES TO R_G. FOR UNITY GAIN APPLICATIONS WHERE R_G IS NOT REQUIRED, THE PADS 1R_G MAY SIMPLY BE BONDED TOGETHER, AS WELL AS THE PADS 8R_G.

CAUTION

ESD (electrostatic discharge) sensitive device. Electrostatic charges as high as 4000 V readily accumulate on the human body and test equipment and can discharge without detection. Although the AD620 features proprietary ESD protection circuitry, permanent damage may occur on devices subjected to high energy electrostatic discharges. Therefore, proper ESD precautions are recommended to avoid performance degradation or loss of functionality.



Typical Characteristics (@ +25°C, $V_S = \pm 15\text{ V}$, $R_L = 2\text{ k}\Omega$, unless otherwise noted)

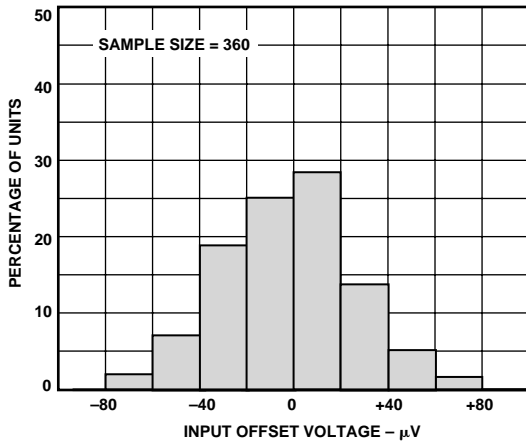

Figure 3. Typical Distribution of Input Offset Voltage

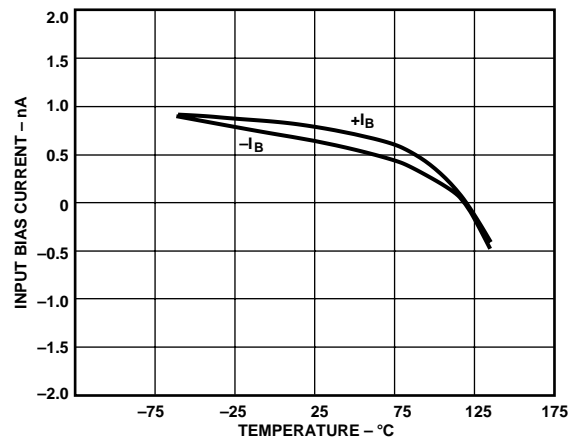

Figure 6. Input Bias Current vs. Temperature

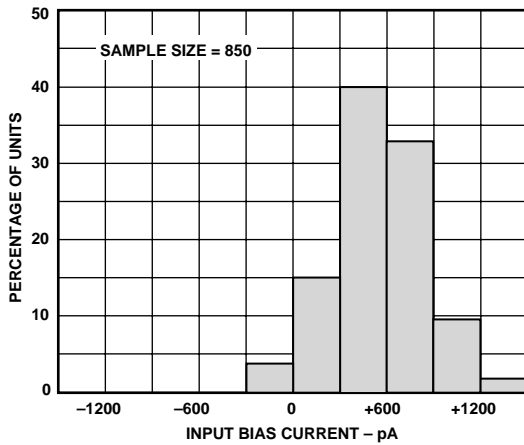

Figure 4. Typical Distribution of Input Bias Current

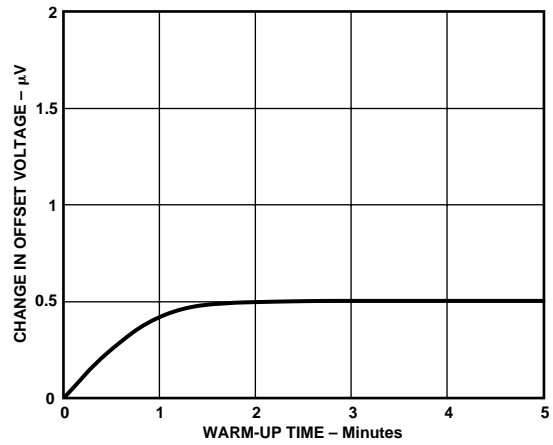

Figure 7. Change in Input Offset Voltage vs. Warm-Up Time

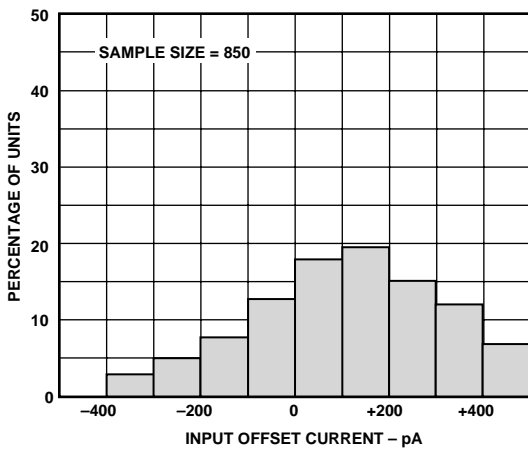

Figure 5. Typical Distribution of Input Offset Current

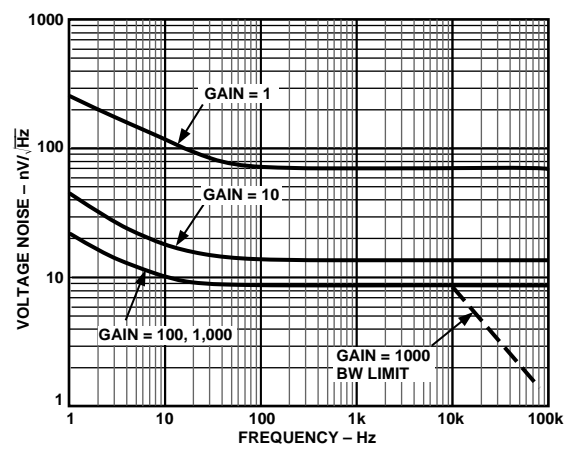

Figure 8. Voltage Noise Spectral Density vs. Frequency, ($G = 1-1000$)

AD620—Typical Characteristics

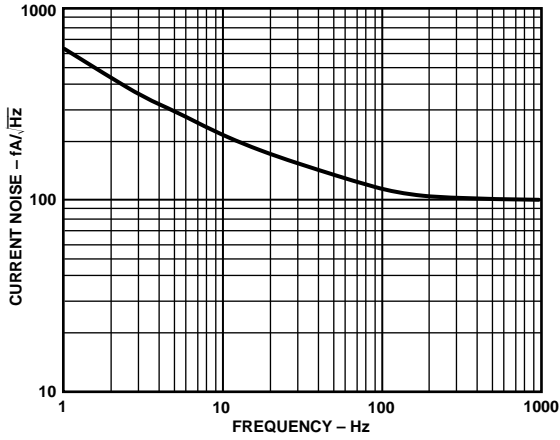

Figure 9. Current Noise Spectral Density vs. Frequency

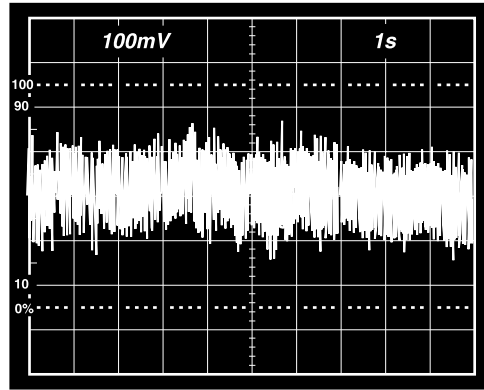

Figure 11. 0.1 Hz to 10 Hz Current Noise, 5 pA/Div

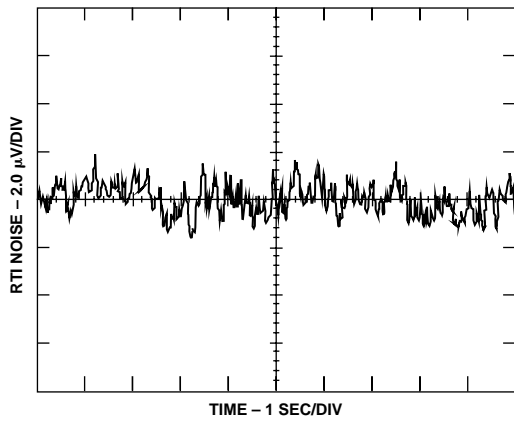

Figure 10a. 0.1 Hz to 10 Hz RTI Voltage Noise ($G = 1$)

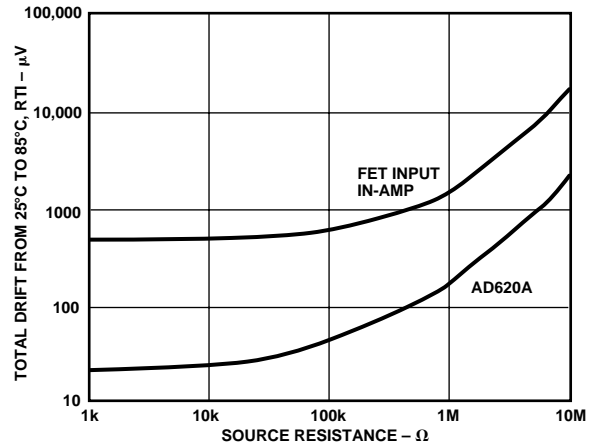

Figure 12. Total Drift vs. Source Resistance

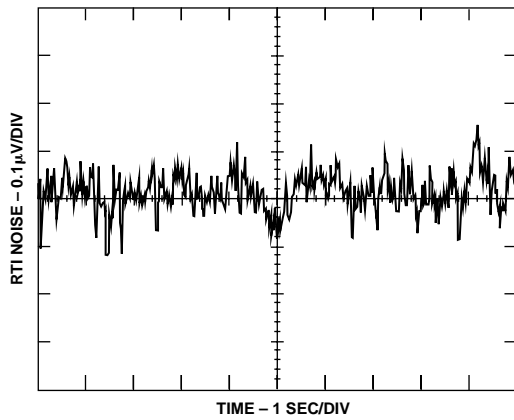

Figure 10b. 0.1 Hz to 10 Hz RTI Voltage Noise ($G = 1000$)

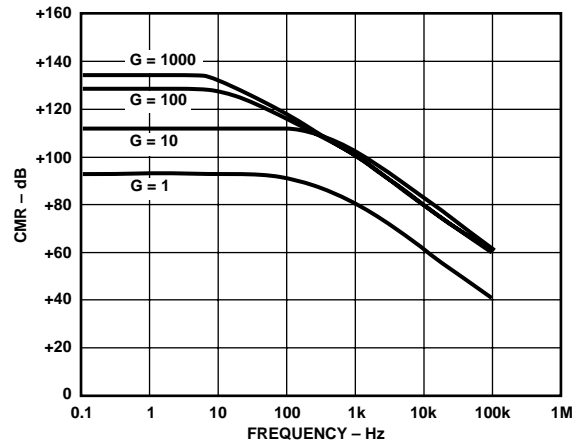

Figure 13. CMR vs. Frequency, RTI, Zero to 1 k Ω Source Imbalance

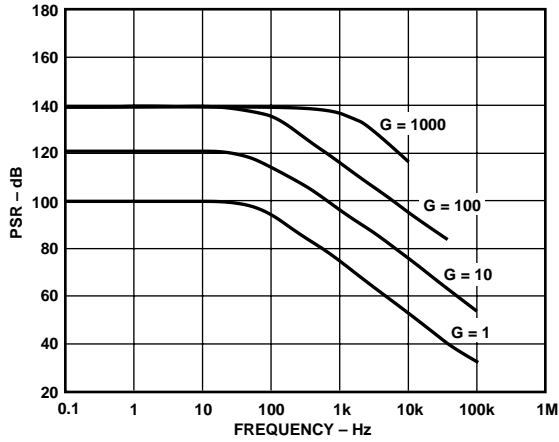

Figure 14. Positive PSR vs. Frequency, RTI ($G = 1-1000$)

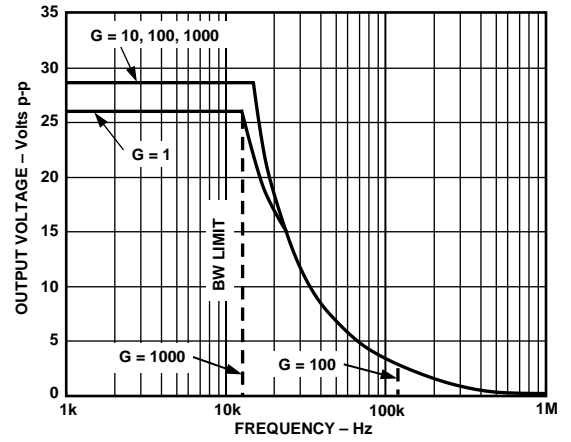

Figure 17. Large Signal Frequency Response

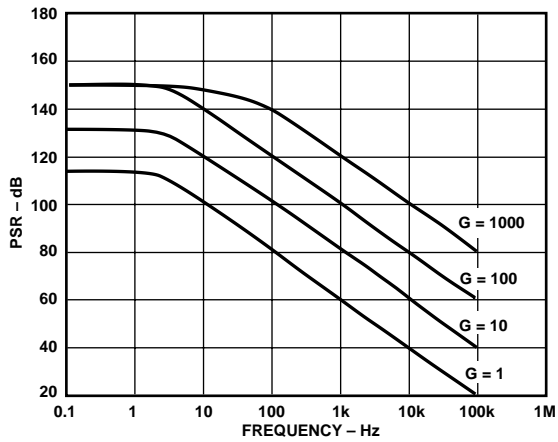

Figure 15. Negative PSR vs. Frequency, RTI ($G = 1-1000$)

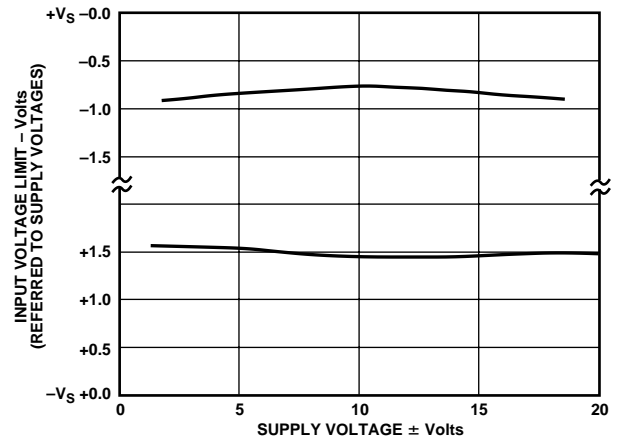

Figure 18. Input Voltage Range vs. Supply Voltage, $G = 1$

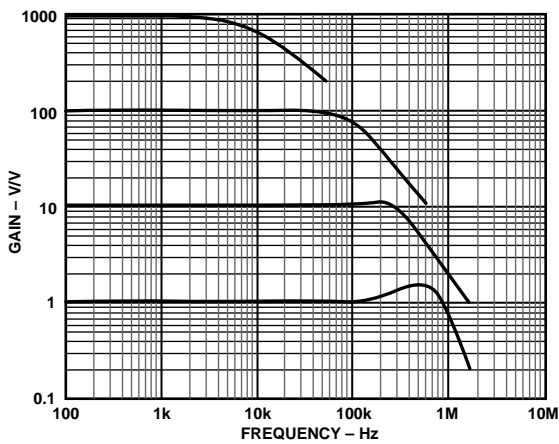

Figure 16. Gain vs. Frequency

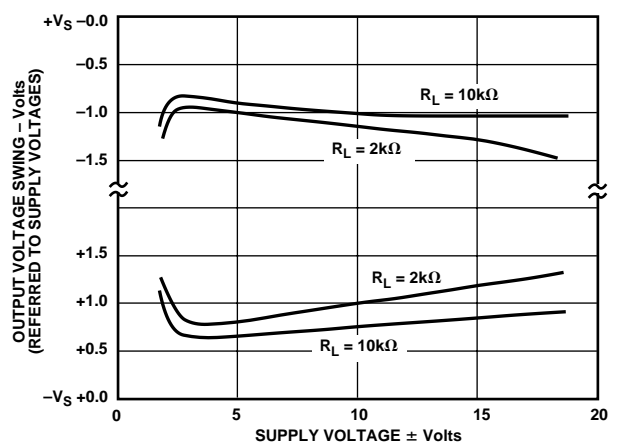

Figure 19. Output Voltage Swing vs. Supply Voltage, $G = 10$

AD620

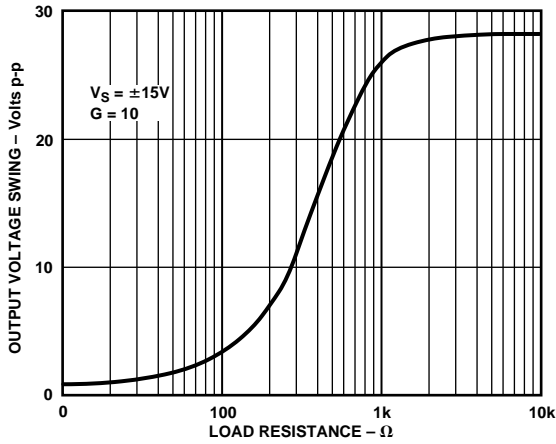

Figure 20. Output Voltage Swing vs. Load Resistance

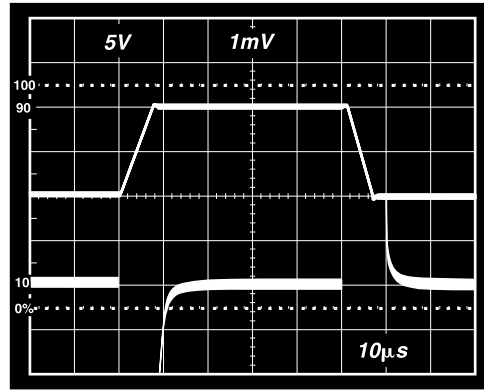

Figure 23. Large Signal Response and Settling Time, $G = 10$ ($0.5 \text{ mV} = 001\%$)

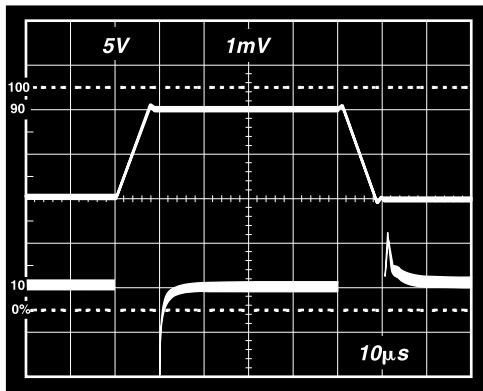

Figure 21. Large Signal Pulse Response and Settling Time $G = 1$ ($0.5 \text{ mV} = 0.01\%$)

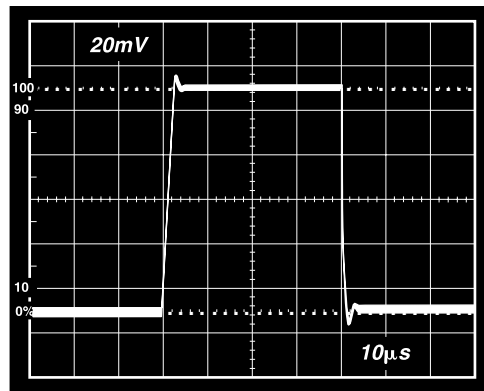

Figure 24. Small Signal Response, $G = 10$, $R_L = 2 \text{ k}\Omega$, $C_L = 100 \text{ pF}$

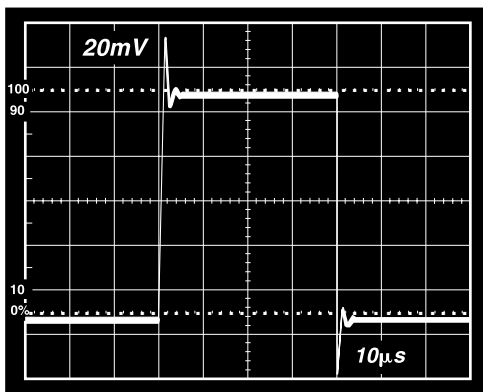

Figure 22. Small Signal Response, $G = 1$, $R_L = 2 \text{ k}\Omega$, $C_L = 100 \text{ pF}$

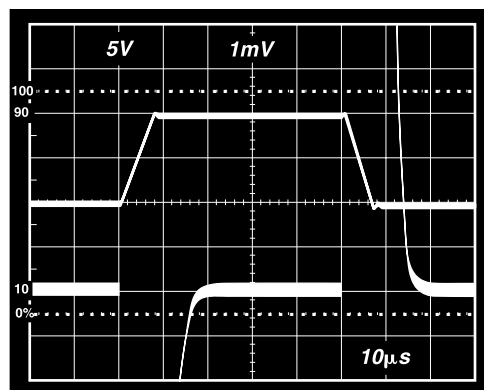

Figure 25. Large Signal Response and Settling Time, $G = 100$ ($0.5 \text{ mV} = 0.01\%$)

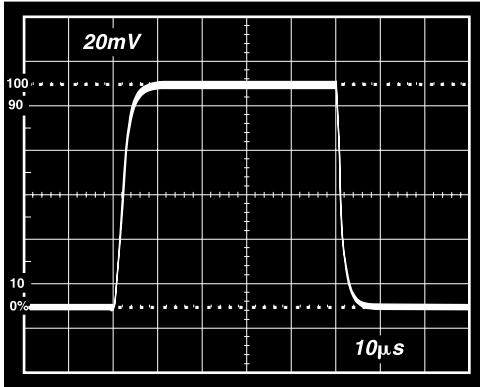

Figure 26. Small Signal Pulse Response, $G = 100$, $R_L = 2\text{ k}\Omega$, $C_L = 100\text{ pF}$

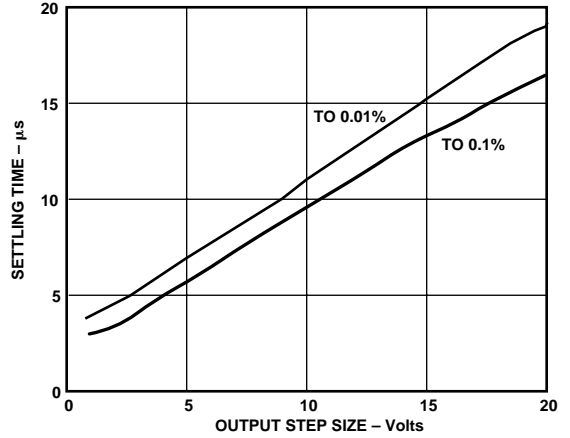

Figure 29. Settling Time vs. Step Size ($G = 1$)

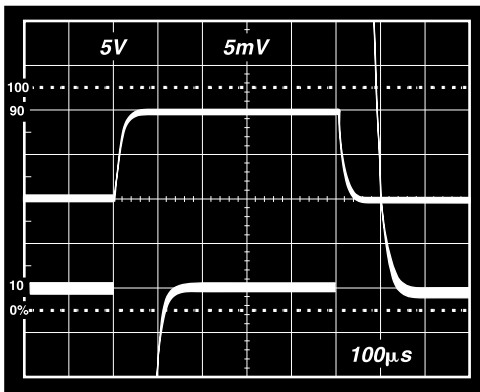

Figure 27. Large Signal Response and Settling Time, $G = 1000$ ($0.5\text{ mV} = 0.01\%$)

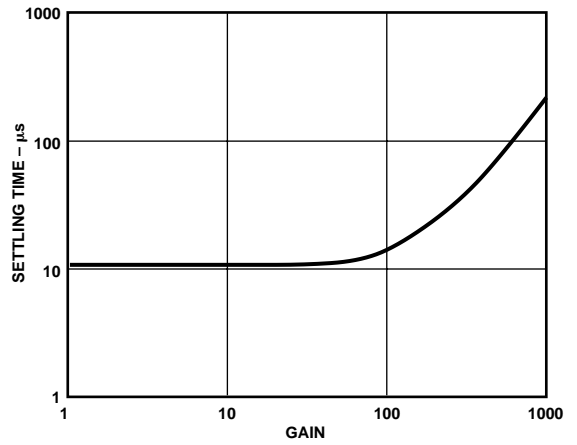

Figure 30. Settling Time to 0.01% vs. Gain, for a 10 V Step

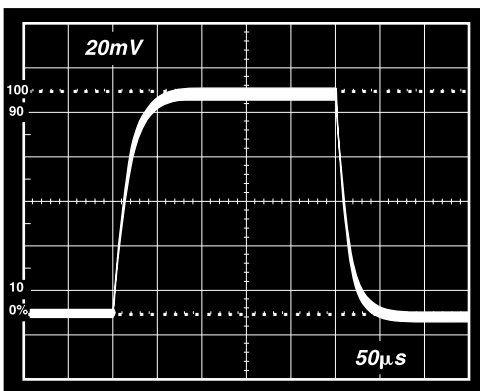

Figure 28. Small Signal Pulse Response, $G = 1000$, $R_L = 2\text{ k}\Omega$, $C_L = 100\text{ pF}$

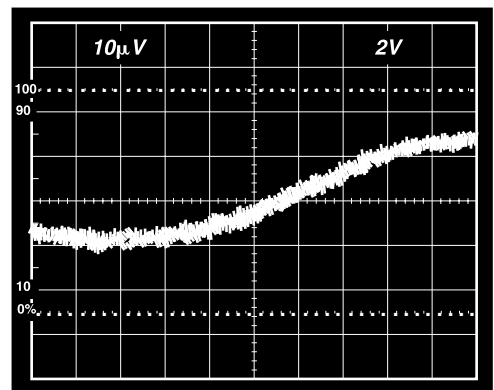

Figure 31a. Gain Nonlinearity, $G = 1$, $R_L = 10\text{ k}\Omega$ ($10\text{ }\mu\text{V} = 1\text{ ppm}$)

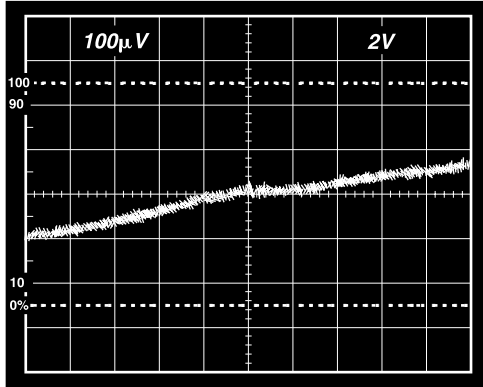

Figure 31b. Gain Nonlinearity, $G = 100$, $R_L = 10\text{ k}\Omega$
($100\text{ }\mu\text{V} = 10\text{ ppm}$)

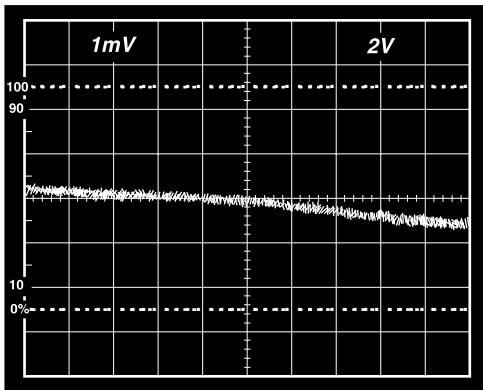

Figure 31c. Gain Nonlinearity, $G = 1000$, $R_L = 10\text{ k}\Omega$
($1\text{ mV} = 100\text{ ppm}$)

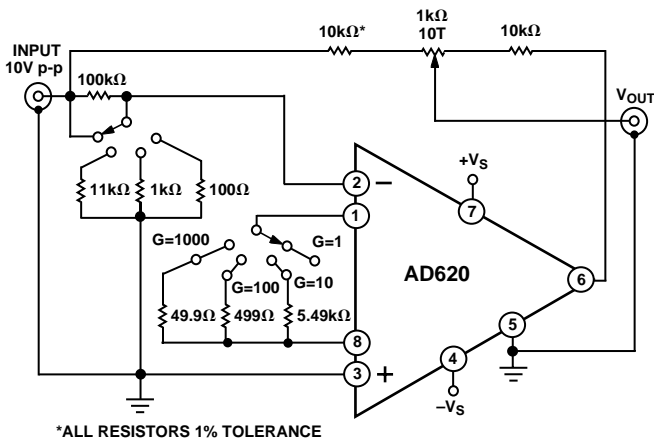

Figure 32. Settling Time Test Circuit

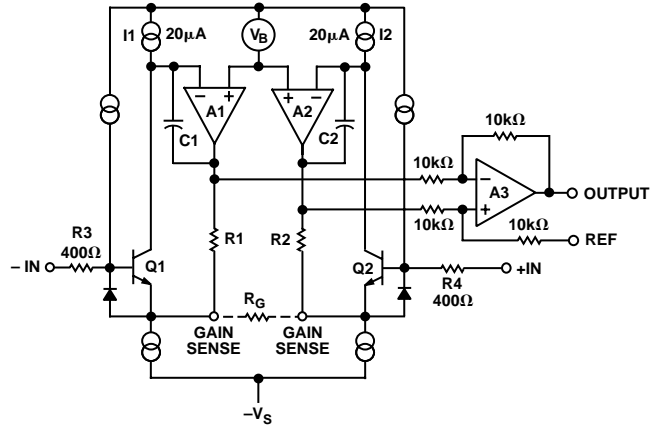

Figure 33. Simplified Schematic of AD620

THEORY OF OPERATION

The AD620 is a monolithic instrumentation amplifier based on a modification of the classic three op amp approach. Absolute value trimming allows the user to program gain accurately (to 0.15% at $G = 100$) with only one resistor. Monolithic construction and laser wafer trimming allow the tight matching and tracking of circuit components, thus ensuring the high level of performance inherent in this circuit.

The input transistors Q1 and Q2 provide a single differential-pair bipolar input for high precision (Figure 33), yet offer $10\times$ lower Input Bias Current thanks to Superbeta processing. Feedback through the Q1-A1-R1 loop and the Q2-A2-R2 loop maintains constant collector current of the input devices Q1, Q2 thereby impressing the input voltage across the external gain setting resistor R_G . This creates a differential gain from the inputs to the A1/A2 outputs given by $G = (R1 + R2)/R_G + 1$. The unity-gain subtracter A3 removes any common-mode signal, yielding a single-ended output referred to the REF pin potential.

The value of R_G also determines the transconductance of the preamp stage. As R_G is reduced for larger gains, the transconductance increases asymptotically to that of the input transistors. This has three important advantages: (a) Open-loop gain is boosted for increasing programmed gain, thus reducing gain-related errors. (b) The gain-bandwidth product (determined by C1, C2 and the preamp transconductance) increases with programmed gain, thus optimizing frequency response. (c) The input voltage noise is reduced to a value of $9\text{ nV}/\sqrt{\text{Hz}}$, determined mainly by the collector current and base resistance of the input devices.

The internal gain resistors, R1 and R2, are trimmed to an absolute value of $24.7\text{ k}\Omega$, allowing the gain to be programmed accurately with a single external resistor.

The gain equation is then

$$G = \frac{49.4\text{ k}\Omega}{R_G} + 1$$

so that

$$R_G = \frac{49.4\text{ k}\Omega}{G - 1}$$

Make vs. Buy: A Typical Bridge Application Error Budget

The AD620 offers improved performance over “homebrew” three op amp IA designs, along with smaller size, fewer components and 10x lower supply current. In the typical application, shown in Figure 34, a gain of 100 is required to amplify a bridge output of 20 mV full scale over the industrial temperature range of -40°C to +85°C. The error budget table below shows how to calculate the effect various error sources have on circuit accuracy.

Regardless of the system in which it is being used, the AD620 provides greater accuracy, and at low power and price. In simple

systems, absolute accuracy and drift errors are by far the most significant contributors to error. In more complex systems with an intelligent processor, an autogain/autozero cycle will remove all absolute accuracy and drift errors leaving only the resolution errors of gain nonlinearity and noise, thus allowing full 14-bit accuracy.

Note that for the homebrew circuit, the OP07 specifications for input voltage offset and noise have been multiplied by $\sqrt{2}$. This is because a three op amp type in-amp has two op amps at its inputs, both contributing to the overall input error.

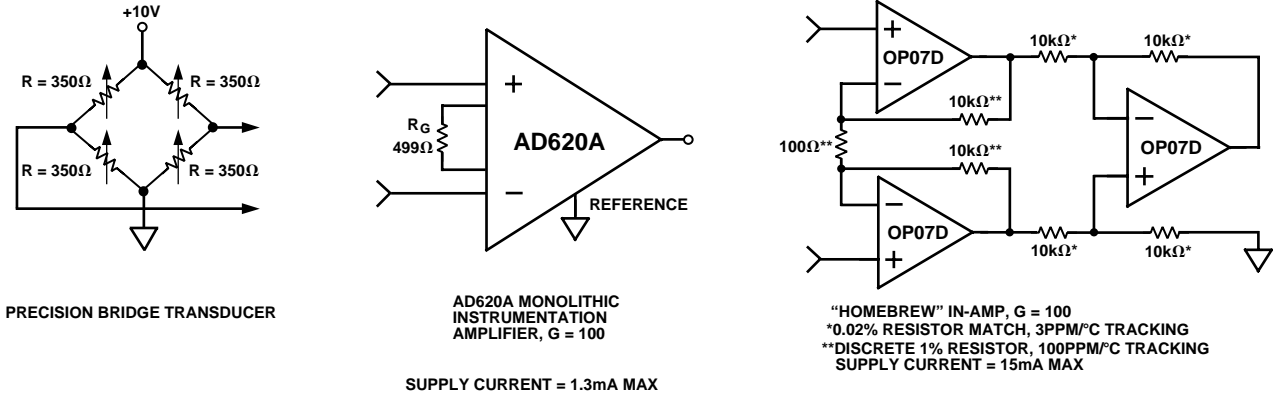

SUPPLY CURRENT = 1.3mA MAX

Figure 34. Make vs. Buy

Table I. Make vs. Buy Error Budget

Error Source	AD620 Circuit Calculation	“Homebrew” Circuit Calculation	Error, ppm of Full Scale	
			AD620	Homebrew
ABSOLUTE ACCURACY at $T_A = +25^\circ\text{C}$				
Input Offset Voltage, μV	125 $\mu\text{V}/20 \text{ mV}$	$(150 \mu\text{V} \times \sqrt{2})/20 \text{ mV}$	6,250	10,607
Output Offset Voltage, μV	1000 $\mu\text{V}/100/20 \text{ mV}$	$((150 \mu\text{V} \times 2)/100)/20 \text{ mV}$	500	150
Input Offset Current, nA	2 nA $\times 350 \Omega/20 \text{ mV}$	$(6 \text{ nA} \times 350 \Omega)/20 \text{ mV}$	18	53
CMR, dB	110 dB $\rightarrow 3.16 \text{ ppm}, \times 5 \text{ V}/20 \text{ mV}$	$(0.02\% \text{ Match} \times 5 \text{ V})/20 \text{ mV}/100$	791	500
DRIFT TO +85°C		Total Absolute Error	7,558	11,310
Gain Drift, ppm/°C	$(50 \text{ ppm} + 10 \text{ ppm}) \times 60^\circ\text{C}$	100 ppm/°C Track $\times 60^\circ\text{C}$	3,600	6,000
Input Offset Voltage Drift, $\mu\text{V}/^\circ\text{C}$	1 $\mu\text{V}/^\circ\text{C} \times 60^\circ\text{C}/20 \text{ mV}$	$(2.5 \mu\text{V}/^\circ\text{C} \times \sqrt{2} \times 60^\circ\text{C})/20 \text{ mV}$	3,000	10,607
Output Offset Voltage Drift, $\mu\text{V}/^\circ\text{C}$	15 $\mu\text{V}/^\circ\text{C} \times 60^\circ\text{C}/100/20 \text{ mV}$	$(2.5 \mu\text{V}/^\circ\text{C} \times 2 \times 60^\circ\text{C})/100/20 \text{ mV}$	450	150
RESOLUTION		Total Drift Error	7,050	16,757
Gain Nonlinearity, ppm of Full Scale	40 ppm	40 ppm	40	40
Typ 0.1 Hz–10 Hz Voltage Noise, $\mu\text{V p-p}$	0.28 $\mu\text{V p-p}/20 \text{ mV}$	$(0.38 \mu\text{V p-p} \times \sqrt{2})/20 \text{ mV}$	14	27
		Total Resolution Error	54	67
		Grand Total Error	14,662	28,134

G = 100, $V_S = \pm 15 \text{ V}$.

(All errors are min/max and referred to input.)

AD620

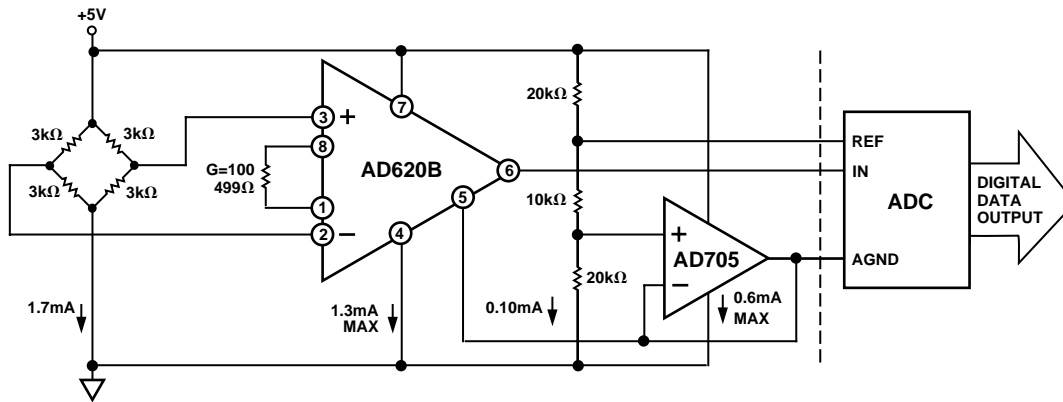

Figure 35. A Pressure Monitor Circuit which Operates on a +5 V Single Supply

Pressure Measurement

Although useful in many bridge applications such as weigh scales, the AD620 is especially suitable for higher resistance pressure sensors powered at lower voltages where small size and low power become more significant.

Figure 35 shows a 3 kΩ pressure transducer bridge powered from +5 V. In such a circuit, the bridge consumes only 1.7 mA. Adding the AD620 and a buffered voltage divider allows the signal to be conditioned for only 3.8 mA of total supply current.

Small size and low cost make the AD620 especially attractive for voltage output pressure transducers. Since it delivers low noise and drift, it will also serve applications such as diagnostic non-invasive blood pressure measurement.

Medical ECG

The low current noise of the AD620 allows its use in ECG monitors (Figure 36) where high source resistances of 1 MΩ or higher are not uncommon. The AD620's low power, low supply voltage requirements, and space-saving 8-lead mini-DIP and SOIC package offerings make it an excellent choice for battery powered data recorders.

Furthermore, the low bias currents and low current noise coupled with the low voltage noise of the AD620 improve the dynamic range for better performance.

The value of capacitor C1 is chosen to maintain stability of the right leg drive loop. Proper safeguards, such as isolation, must be added to this circuit to protect the patient from possible harm.

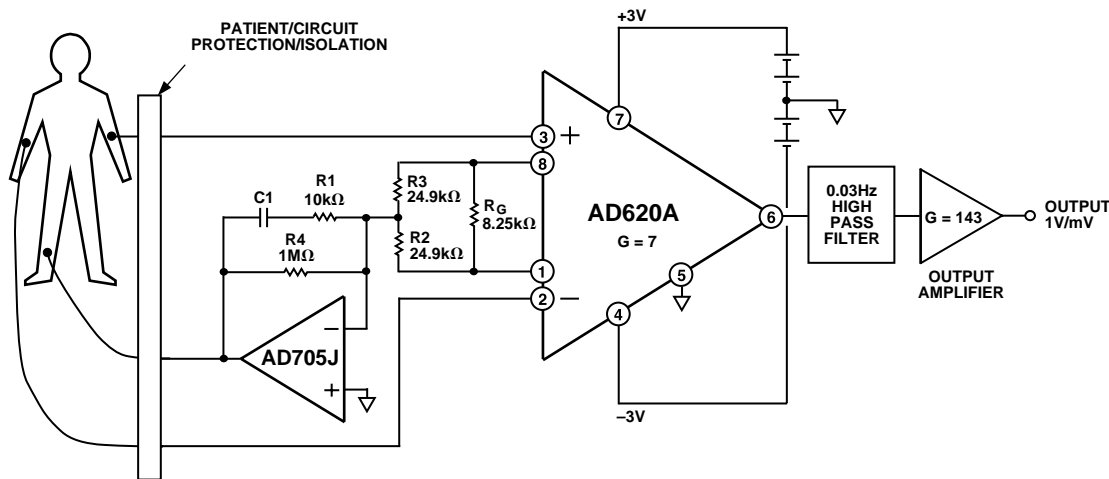

Figure 36. A Medical ECG Monitor Circuit

Precision V-I Converter

The AD620, along with another op amp and two resistors, makes a precision current source (Figure 37). The op amp buffers the reference terminal to maintain good CMR. The output voltage V_X of the AD620 appears across R_1 , which converts it to a current. This current less only, the input bias current of the op amp, then flows out to the load.

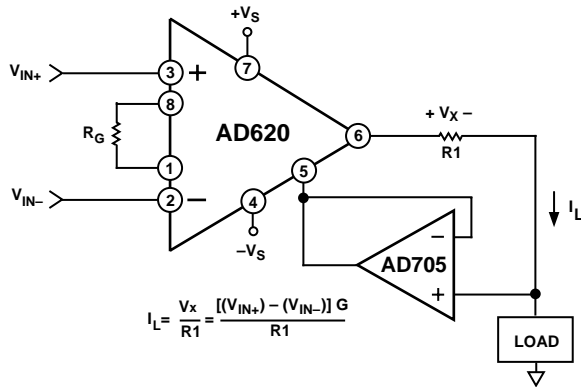

Figure 37. Precision Voltage-to-Current Converter (Operates on 1.8 mA, ±3 V)

$$I_L = \frac{V_X}{R_1} = \frac{[(V_{IN+}) - (V_{IN-})] G}{R_1}$$

GAIN SELECTION

The AD620's gain is resistor programmed by R_G , or more precisely, by whatever impedance appears between Pins 1 and 8. The AD620 is designed to offer accurate gains using 0.1%–1% resistors. Table II shows required values of R_G for various gains. Note that for $G = 1$, the R_G pins are unconnected ($R_G = \infty$). For any arbitrary gain R_G can be calculated by using the formula:

$$R_G = \frac{49.4 \text{ k}\Omega}{G - 1}$$

To minimize gain error, avoid high parasitic resistance in series with R_G ; to minimize gain drift, R_G should have a low TC—less than 10 ppm/°C—for the best performance.

Table II. Required Values of Gain Resistors

1% Std Table Value of R_G , Ω	Calculated Gain	0.1% Std Table Value of R_G , Ω	Calculated Gain
49.9 k	1.990	49.3 k	2.002
12.4 k	4.984	12.4 k	4.984
5.49 k	9.998	5.49 k	9.998
2.61 k	19.93	2.61 k	19.93
1.00 k	50.40	1.01 k	49.91
499	100.0	499	100.0
249	199.4	249	199.4
100	495.0	98.8	501.0
49.9	991.0	49.3	1,003

INPUT AND OUTPUT OFFSET VOLTAGE

The low errors of the AD620 are attributed to two sources, input and output errors. The output error is divided by G when referred to the input. In practice, the input errors dominate at high gains and the output errors dominate at low gains. The total V_{OS} for a given gain is calculated as:

$$\text{Total Error RTI} = \text{input error} + (\text{output error}/G)$$

$$\text{Total Error RTO} = (\text{input error} \times G) + \text{output error}$$

REFERENCE TERMINAL

The reference terminal potential defines the zero output voltage, and is especially useful when the load does not share a precise ground with the rest of the system. It provides a direct means of injecting a precise offset to the output, with an allowable range of 2 V within the supply voltages. Parasitic resistance should be kept to a minimum for optimum CMR.

INPUT PROTECTION

The AD620 features 400 Ω of series thin film resistance at its inputs, and will safely withstand input overloads of up to ± 15 V or ± 60 mA for several hours. This is true for all gains, and power on and off, which is particularly important since the signal source and amplifier may be powered separately. For longer time periods, the current should not exceed 6 mA ($I_{IN} \leq V_{IN}/400 \Omega$). For input overloads beyond the supplies, clamping the inputs to the supplies (using a low leakage diode such as an FD333) will reduce the required resistance, yielding lower noise.

RF INTERFERENCE

All instrumentation amplifiers can rectify out of band signals, and when amplifying small signals, these rectified voltages act as small dc offset errors. The AD620 allows direct access to the input transistor bases and emitters enabling the user to apply some first order filtering to unwanted RF signals (Figure 38), where $RC \approx 1/(2 \pi f)$ and where $f \geq$ the bandwidth of the AD620; $C \leq 150$ pF. Matching the extraneous capacitance at Pins 1 and 8 and Pins 2 and 3 helps to maintain high CMR.

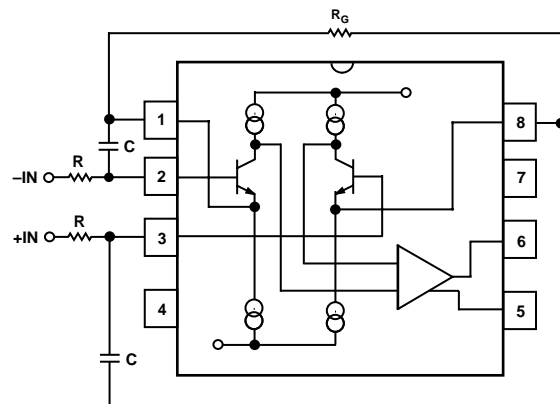

Figure 38. Circuit to Attenuate RF Interference

AD620

COMMON-MODE REJECTION

Instrumentation amplifiers like the AD620 offer high CMR, which is a measure of the change in output voltage when both inputs are changed by equal amounts. These specifications are usually given for a full-range input voltage change and a specified source imbalance.

For optimal CMR the reference terminal should be tied to a low impedance point, and differences in capacitance and resistance should be kept to a minimum between the two inputs. In many applications shielded cables are used to minimize noise, and for best CMR over frequency the shield should be properly driven. Figures 39 and 40 show active data guards that are configured to improve ac common-mode rejections by “bootstrapping” the capacitances of input cable shields, thus minimizing the capacitance mismatch between the inputs.

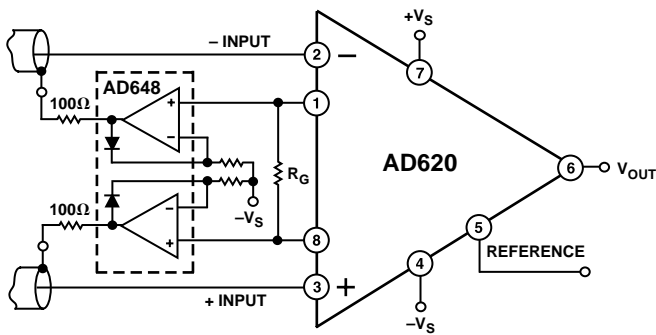

Figure 39. Differential Shield Driver

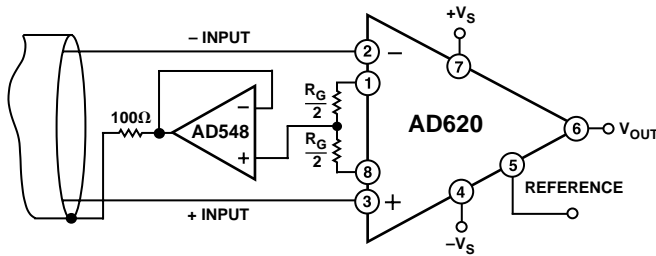

Figure 40. Common-Mode Shield Driver

GROUNDING

Since the AD620 output voltage is developed with respect to the potential on the reference terminal, it can solve many grounding problems by simply tying the REF pin to the appropriate “local ground.”

In order to isolate low level analog signals from a noisy digital environment, many data-acquisition components have separate analog and digital ground pins (Figure 41). It would be convenient to use a single ground line; however, current through ground wires and PC runs of the circuit card can cause hundreds of millivolts of error. Therefore, separate ground returns should be provided to minimize the current flow from the sensitive points to the system ground. These ground returns must be tied together at some point, usually best at the ADC package as shown.

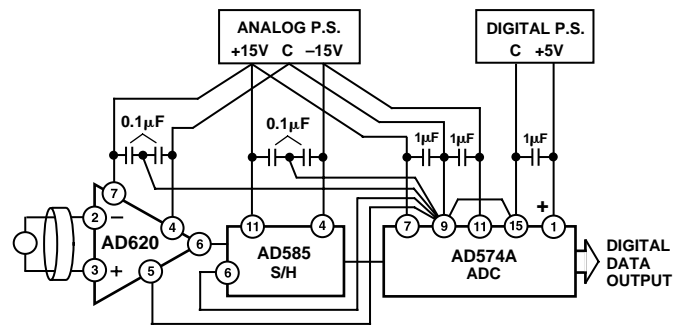

Figure 41. Basic Grounding Practice

GROUND RETURNS FOR INPUT BIAS CURRENTS

Input bias currents are those currents necessary to bias the input transistors of an amplifier. There must be a direct return path for these currents; therefore, when amplifying “floating” input

sources such as transformers, or ac-coupled sources, there must be a dc path from each input to ground as shown in Figure 42. Refer to the *Instrumentation Amplifier Application Guide* (free from Analog Devices) for more information regarding in amp applications.

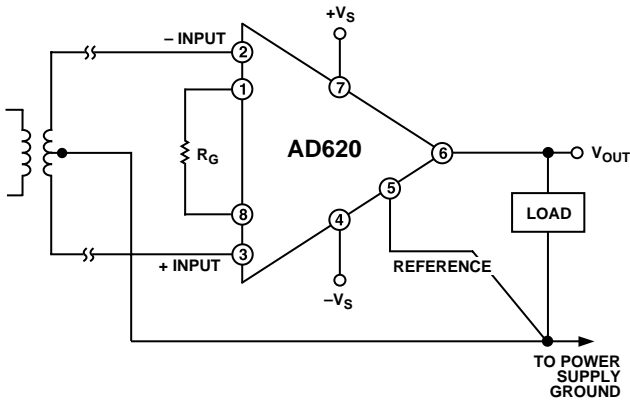

Figure 42a. Ground Returns for Bias Currents with Transformer Coupled Inputs

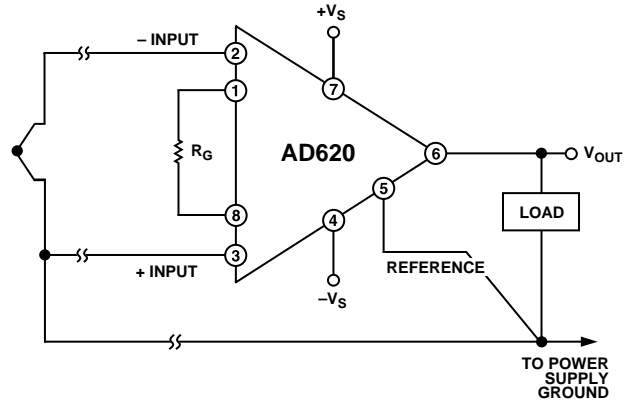

Figure 42b. Ground Returns for Bias Currents with Thermocouple Inputs

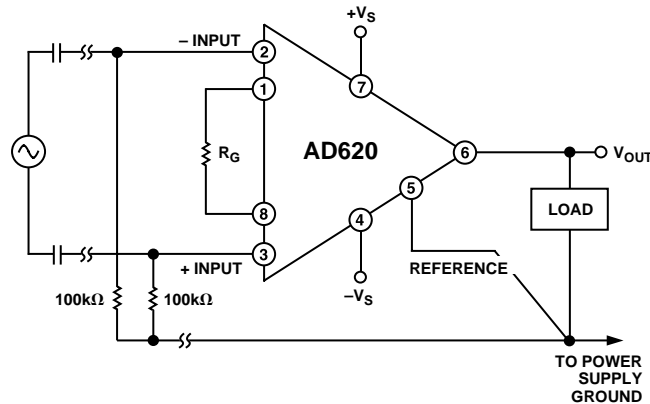
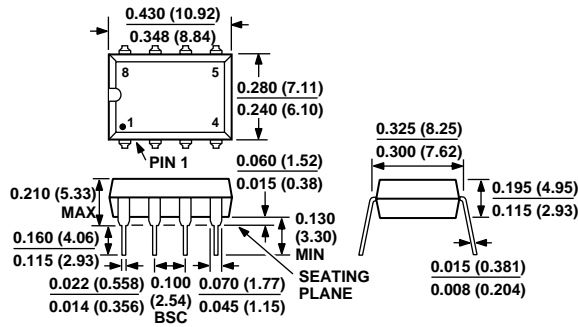

Figure 42c. Ground Returns for Bias Currents with AC Coupled Inputs

OUTLINE DIMENSIONS

Dimensions shown in inches and (mm).

Plastic DIP (N-8) Package



Cerdip (Q-8) Package

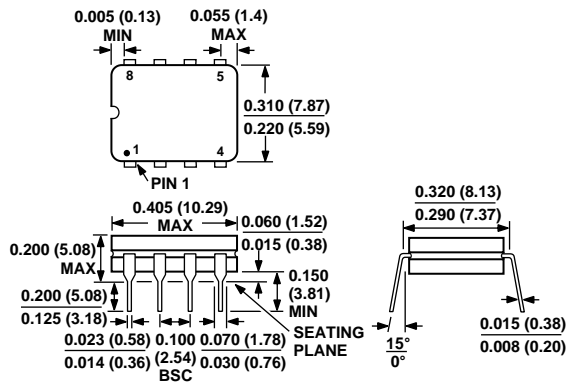

SOIC (SO-8) Package

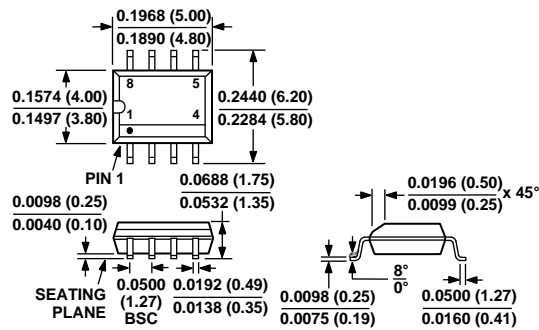



LittleDiode supplies new, hard to find or obsolete electronic components and semiconductors all over the world.

With over two million different components listed you are sure to find the part you need.

Feel free to visit us today at our online store:

LittleDiode.com

Looking forward to providing you with the best possible service.