

**I<sup>2</sup>C BUS CONTROLLED EAST-WEST  
AND VERTICAL INTERFACE**

- INTEGRATED VERTICAL SAWTOOTH GENERATOR WITH AMPLITUDE CONTROL LOOP (50Hz - 60Hz)
- INTERLACE MODE INTRINSICALLY CONTROLLED BY STV2118A
- VERTICAL SIZE CORRECTION (BREATHING) TO ADAPT DEFLECTION SENSITIVITY TO THE CURRENT BEAM (HIGH VOLTAGE VARIATION)
- BUS ADJUSTED VERTICAL PARAMETERS : VERTICAL AMPLITUDE, VERTICAL POSITION AND S-CORRECTION
- EAST-WEST FUNCTION GENERATOR WITH INTEGRATED ERROR AMPLIFIER (THUS, ONLY 1 EXTERNAL POWER DARLINGTON IS NECESSARY FOR EW-FUNCTION)
- BUS CONTROLLED EAST-WEST FUNCTIONS : EW-AMPLITUDE, HORIZONTAL WIDTH, EW-TILT AND EW-SHAPE (CORNER CORRECTION)
- OVERSIZE BLANKING (VERTICAL AND HORIZONTAL) WHICH PERMIT ZOOM AND SUBTITLE FACILITIES FOR 4/3 AND 16/9 CRTs

**DESCRIPTION**

The STV2145 is an I<sup>2</sup>C bus processor containing the vertical deflection East-West functions and oversize blanking. This circuit is foreseen as ADD-ON for the Video Chroma Processor STV2118A to permit 110° CRT applications covering standard 4/3 screen format and new 16/9 format with zoom and subtitle facilities. STV2145 has been designed to drive a standard TDA8172/8177 vertical booster and an external transistor for East-West.

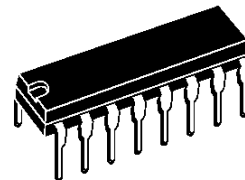

**DIP16**  
(Plastic Package)

**ORDER CODE : STV2145**

**PIN CONNECTIONS**

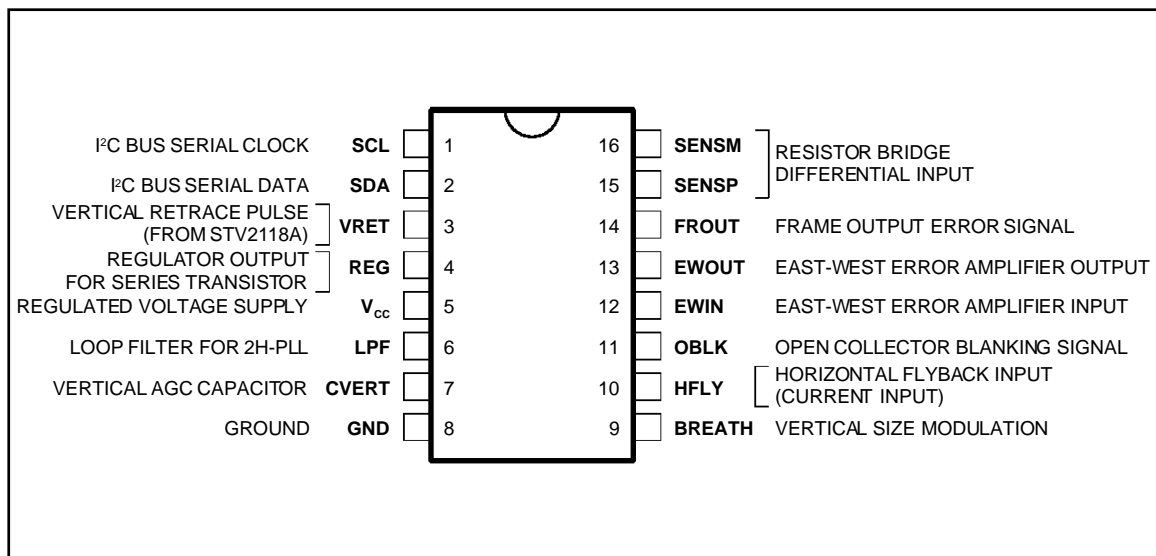

2145-01.EPS

**PIN DESCRIPTION**

Pin N°	Name	Function	Description
1	SCL	Serial Clock for I <sup>2</sup> C Bus	Data input (no pull down - capability)
2	SDA	Serial Data for I <sup>2</sup> C Bus	Data input and output (pull down - capability for acknowledge and data reply)
3	VRET	Vertical Reset Input	Vertical Synchronization Signal from STV2118A
4	REG	Control Pin for Regulator	Output for controlling the ext. series regulator transistor
5	V <sub>CC</sub>	Supply Voltage Scanning	Supply voltage of scanning part, connected with external series regulator transistor
6	LPF	Loop Filter for PLL	Loop filter for horizontal 2 x F <sub>LINE</sub> VCO
7	CVERT	Vertical AGC Capacitor	Regulation of vertical saw tooth amplitude
8	GND	Ground	Ground
9	BREATH	Breathing Input	Input voltage = 1 to 7.8V = vertical size compensation
10	HFLY	Horizontal Flyback Input	Voltage input for horizontal flyback, polarity positive
11	OBLK	Oversize Blanking Signal	Oversize blanking output : - open collector output : high ohmic = blanking - low (transistor saturated) = no blanking
12	EWIN	East-West Input	Input of the error amplifier for the East-West modulator
13	EWOUT	East-West Output	Output of the error amplifier for the East-West modulator (current output, biasing directly the darlington output transistor)
14	FROUT	Output for Frame Amplifier	Output of transconductance amplifier, pin has to be connected to the inverting input of the vertical power amplifier
15	SENSP	Sense Input, Positive	Input of internal resistor bridge for sensing the vertical deflection YOKE current
16	SENSM	Sense Input, Negative	Input of internal resistor bridge for sensing the vertical deflection YOKE current

2145-01.TBL

BLOCK DIAGRAM

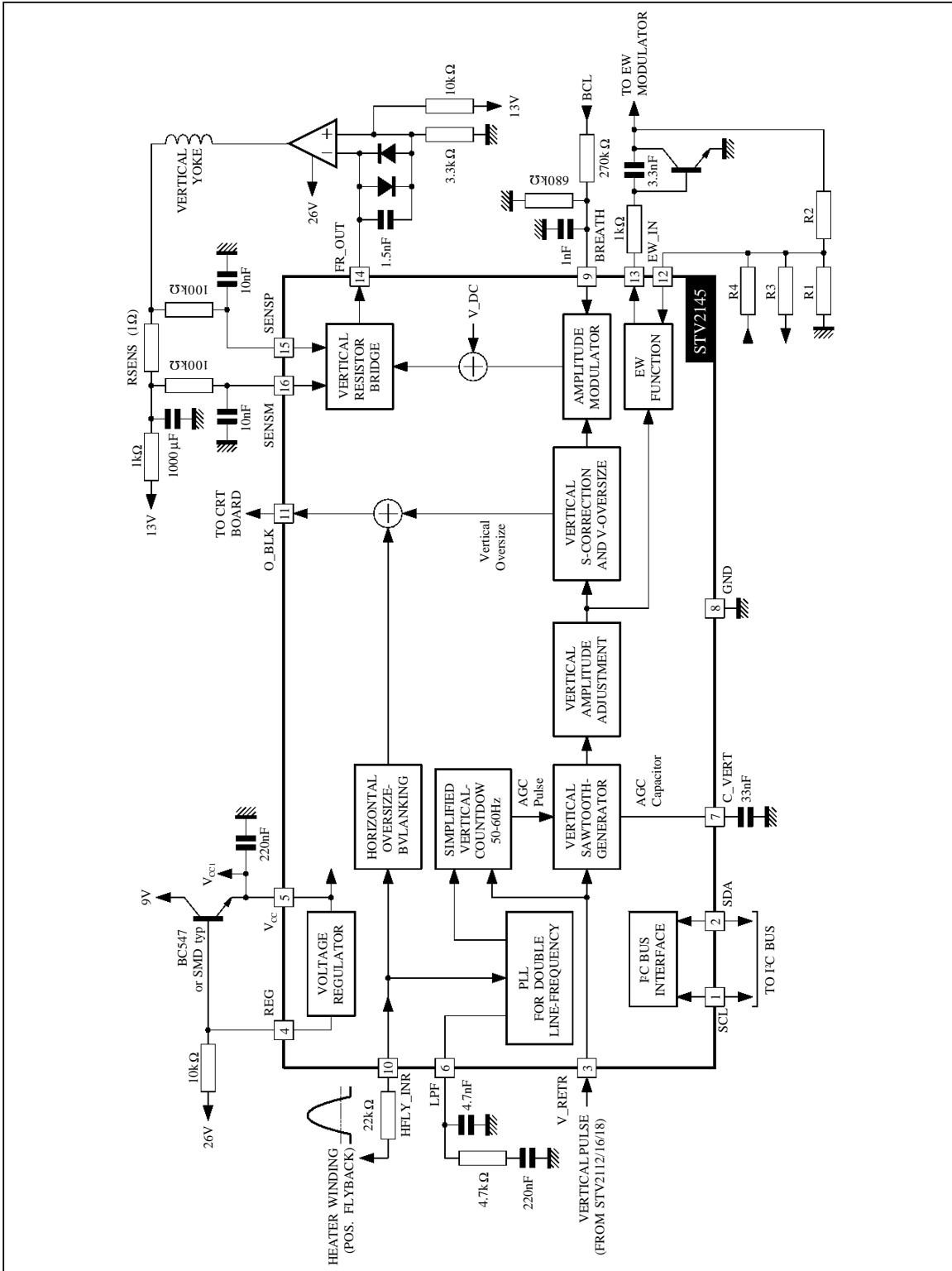

2145-02.EPS

## STV2145

### I<sup>2</sup>C BUS INFORMATION

#### Slave Address

hex 8C/8D

MSB							LSB
1	0	0	0	1	1	0	R/W

#### Address Mapping (write mode)

x = don't care bits, not used for the decoding of the subaddress.

Subaddress		Data Bits					
Binary	Hex	MSB					LSB
xxxx000	x0 or x8		TEST_MODE	VERTICAL OVERSIZE BLANKING 2	VERTICAL OVERSIZE BLANKING 1	S_CORRECTION	
xxxx001	x1 or x9		V_AMPLITUDE				
xxxx010	x2 or xA		TEST_MODE	SUB_TITLE	V_DC		
xxxx011	x3 or xB		HORIZONTAL OVERSIZE BLANKING 2	HORIZONTAL OVERSIZE BLANKING 1	EW_AMPLITUDE		
xxxx100	x4 or xC					EW_SHAPE	
xxxx101	x5 or xD		EW_LOW		EW_TILT		
xxxx110	x6 or xE		TEST_MODE	H_WIDTH			

#### Subaddress 0 (hex 00) : Vertical Oversize Blanking & S\_CORRECTION

MSB						LSB
TEST_MODE	OV_BLK_VERT2	OV_BLK_VERT1	S3	S2	S1	S0

TEST\_MODE : 0 : Normal operations  
 1 : Reserved for SGS-THOMSON test

OV\_BLK\_VERT1, : Vertical oversize blanking (register SUB\_TITLE in subadress X2 or XA)  
 OV\_BLK\_VERT2 (see Table 1)

**Table 1**

TV Mode	Sent Frequency (via VRET)	OV_BLK_VERT 2	OV_BLK_VERT 1	SUB_TITLE	Start of Blanking (middle of line)	End of Blanking (middle of line)
STANDARD 4 :3	50Hz 60Hz	0	0	0	No Blanking	
SUBTITLE	50Hz 60Hz	Don't Care	Don't Care	1	302 259	67 59
ZOOM1	50Hz 60Hz	0	1	0	285 239	49 43
ZOOM2	50Hz 60Hz	1	1	0	278 234	59 49
BLANK	50Hz 60Hz	1	0	0	Full Blanking	

S1, S2, S3, S4 : S-CORRECTION

0000 (hex 00) : Maximal S-CORRECTION

1111 (hex 0F) : Minimal S-CORRECTION (vertical sawtooth flat)

**I<sup>2</sup>C BUS INFORMATION** (continued)**Subaddress 1 (hex 01) : Vertical Sawtooth Amplitude**

MSB						LSB
V6	V5	V4	V3	V2	V1	V0

V6, V5, V4, V3, : V\_AMPLITUDE  
 V2, V1, V0 : 000000 (hex 00) : Minimal V\_AMPLITUDE (0.46V<sub>PP</sub> on SENSP/SENSM)  
 111111 (hex 7F) : Maximal V\_AMPLITUDE (1.16V<sub>PP</sub> on SENSP/SENSM)

**Subaddress 2 (hex 02) : Vertical Shift & Vertical Position**

MSB				LSB		
TEST_MODE	SUB_TITLE	V4	V3	V2	V1	V0

TEST\_MODE : 0 : Normal operations  
 1 : Reserved for SGS-THOMSON test

SUB\_TITLE : DC shift of vertical sawtooth  
 0 : Normal operations  
 1 : Vertical Sawtooth shifted by 90mV upwards and unsymmetrical vertical  
 oversize blanking (if nominal amplitude = V\_AMPLITUDE = hex40)

V4, V3, V2, V1, V0 : Vertical position (V\_DC)  
 00000 (hex 00) : Minimal position (picture shifted down by -65mV on SENSP/SENSM)  
 11111 (hex 1F) : Maximal position (picture shifted up by +65mV on SENSP/SENSM)

**Subaddress 3 (hex 03) : Horizontal Oversize Blanking & EW-Amplitude**

MSB					LSB	
OV_BLK_HOR2	OV_BLK_HOR1	E4	E3	E2	E1	E0

OV\_BLK\_HOR1, : Horizontal oversize blanking (see Table 2)  
 OV\_BLK\_HOR2

**Table 2**

TV Mode	OV_BLK_HOR2	OV_BLK_HOR1	Reference is Rising Edge of Positive HFLY-Back (µs)	
			Start of Blanking	End of Blanking
STANDARD 4:3	0	Don't Care	0	11.5
ZOOM1 (14:9)	1	0	-1.7	13.7
ZOOM2 (16:9)	1	1	-3.2	15.2

E4, E3, E2, E1, E0 : EW-AMPLITUDE  
 00000 (hex 00) : Maximal parabola amplitude = 0.74V for EW\_LOW = 0 ; 0.48V for  
 EW\_LOW = 1  
 11111 (hex 1F) : Minimal parabola amplitude = 0.26V for EW\_LOW = 0 ; 0.0V for  
 EW\_LOW = 1

**Subaddress 4 (hex 04) : EW\_SHAPE**

EW\_SHAPE : 0000 (hex 00) : Maximal parabola flattening (flattened corners of parabola)  
 1111 (hex 0F) : Minimal parabola flattening (ideal parabola)

**I<sup>2</sup>C BUS INFORMATION** (continued)

**Subaddress 5 (hex 05) : EW\_Parabola Range Switch & East-West - Tilt Adjustment**

MSB					LSB	
	EW_LOW	T4	T3	T2	T1	T0

EW\_LOW : Switch for parabola amplitude range  
 0 : Parabola amplitude from 0.26 to 0.74V  
 1 : Parabola amplitude from 0 to 0.48V

T4, T3, T2, T1, T0 : East-west tilt (unsymmetry)  
 00000 (hex 00) : Minimal position : parabola unsymmetrical, (higher on the top of the picture)  
 10000 (hex 10) : Parabola symmetrical  
 11111 (hex 1F) : Maximal position : parabola unsymmetrical, (lower on the top of the picture)

**Subaddress 6 (hex 06) : Picture Width (H\_WIDTHH)**

MSB					LSB	
TEST_MODE	W5	W4	W3	W2	W1	W0

TEST\_MODE : 0 : Normal operations  
 1 : Reserved for SGS-THOMSON test

W5, W4, W3, W2, W1, W0 : H\_WIDTHH (picture width)  
 000000 (hex 00) : Minimal position : DC\_Value of parabola minimal  
 111111 (hex 3F) : Maximal position : DC\_Value of parabola maximal

**Output Signals (Read Mode)**

MSB				LSB	
PON_RESET	S60/50	VCO_LOCK	VERS_NBR	VERS_EXT	

PON\_RESET : 1 : If Voltage drop has been detected (risk of data loss in latch memory)

S60/50 : 0 : If VRET frequency = 50Hz  
 1 : If VRET frequency = 60Hz

VCO\_LOCK : 0 : If PLL FH2 is out of frequency or phase  
 1 : If PLL FH2 has locked

VERS\_NBR : Number of actual cut (for SGS-THOMSON use)

VERS\_EXT : Number of metal version (for SGS-THOMSON use)

## ABSOLUTE MAXIMUM RATINGS

Symbol	Parameter	Value	Unit
V <sub>CC</sub>	Supply Voltage (pin 5)	9	V
V <sub>SCL</sub> , V <sub>SDA</sub>	Separated Protection Structures to these Pins 1 and 2	6	V
V <sub>SENSP</sub> , V <sub>SENSM</sub>	No Protection Diodes to V <sub>CC</sub> in Order to Allow Half Bridge Operation (Pins 15 and 16)	20	V
T <sub>oper</sub>	Operating Ambient Temperature	0, +70	°C
T <sub>stg</sub>	Storage Temperature	-55, +150	°C

2145-02.TBL

## THERMAL DATA

Symbol	Parameter	Value	Unit
R <sub>th(j-a)</sub>	Junction-ambient Thermal Resistance	Max. 70	°C/W

2145-03.TBL

ELECTRICAL CHARACTERISTICS (V<sub>CC</sub> = 7.8V, T<sub>amb</sub> = 25°C, unless otherwise specified)

Symbol	Parameter	Test Conditions	Min.	Typ.	Max.	Unit
--------	-----------	-----------------	------	------	------	------

## SUPPLY (Pin 5) (see Note 1)

P <sub>max</sub>	Total Power Consumption	Typical power consumption		0.15		W
I <sub>max</sub>	Current Capability (Pin 4)	Maximum current pulled down by Pin 4			15	mA
	Line Ripple Rejection (see Note 2)	External transistor, Pin 4 connected with 3.3kΩ against Power Supply (e.g. 12V ; recommended current into REG = 1mA), ΔV <sub>CC</sub> / ΔV <sub>power</sub>	-35			dB
	Load Regulation (see Note 2)	External transistor, Pin 4 connected with 3.3kΩ against Power Supply (12V), ΔV <sub>CC</sub> / ΔI <sub>E(regulation transistor)</sub>			1	mV/mA
V <sub>NOM</sub>	Regulation Voltage	External regulation transistor, Pin 4 connected via 3.3kΩ resistor against 12V	7.5	7.8	8.2	V

I<sup>2</sup>C BUS (Pins 1 and 2)

V <sub>TH</sub>	Input Threshold Voltage		1.5	2.1	2.7	V
I <sub>BUS</sub>	Input Current	V <sub>1</sub> and V <sub>2</sub> = 5V			40	μA
Data	Saturation Voltage	Open collector of pull-down transistor at 5mA			0.5	V
	Pull-down Current	No pull-down capability. Pin 1 can't be pulled down to slow down clock SCL of microprocessor				
f <sub>Max.</sub>	Maximum Toggle Frequency		200			kHz

## TIME BASE GENERATION INTERFACES

HFLY INTERFACE (Pin 10)						
	Polarity of Horizontal Flyback	Preferable heater-winding of EHT-transformer (flyback voltage positive during horizontal flyback)	Positive			
V <sub>TH</sub>	Threshold Voltage	V <sub>BE</sub> voltage comparator	0.5	0.7	1.0	V
V <sub>CLP</sub>	Positive Clamp Voltage	Clamping voltage = V <sub>TH</sub> + V <sub>BE</sub>		1.6		V
I <sub>CLPP</sub>	Maximum Positive Clamping Current	Input voltage exceeds positive clamping voltage			4	mA
V <sub>CLP</sub>	Negative Clamping Voltage	Clamping voltage = V <sub>TH</sub> - V <sub>BE</sub>		0		V
I <sub>CLPP</sub>	Minimum Negative Clamping Current	Input voltage smaller than negative clamping voltage	-2			mA

2145-04.TBL

- Notes :**
- Supply voltage is regulated via external series regulator transistor.
  - Parameter is not tested during production, but it is guaranteed by the design and qualified by means of corner lots.

**ELECTRICAL CHARACTERISTICS** (continued) ( $V_{CC} = 7.8V$ ,  $T_{amb} = 25^{\circ}C$ , unless otherwise specified)

Symbol	Parameter	Test Conditions	Min.	Typ.	Max.	Unit
TIME-BASE GENERATION INTERFACES (continued)						
OVERSIZE BLANKING OUTPUT (Pin 11) (see Note 3)						
$I_O$	Output Current	$V_{OBLK}$ (Saturation Voltage) < 0.5V			10	mA
$V_O$	Output Voltage	$I_{OBLK} = 5mA$	0		0.4	V
$t_R, t_F$	Rise Time / Fall Time	Output Load = 2.2k $\Omega$ against $V_{CC}$		100		ns
HORIZONTAL OVERSIZE BLANKING (Pin 11) (see Figure 1)						
$OB_R$ $OB_L$	Horizontal Oversize	Bus register $OV\_BLK\_HOR1,2 = (00)$		-0.3 0.3		$\mu s$ $\mu s$
$OB_R$ $OB_L$	Horizontal Oversize	Bus register $OV\_BLK\_HOR1,2 = (01)$	1.45 1.5	1.9 1.7	2.35 1.9	$\mu s$ $\mu s$
$OB_R$ $OB_L$	Horizontal Oversize	Bus register $OV\_BLK\_HOR1,2 = (11)$	2.95 2.9	3.4 3.2	3.85 3.6	$\mu s$ $\mu s$
$OB_R$ $OB_L$	Horizontal Oversize Blanking Unsymmetry	Bus register $OV\_BLK\_HOR1,2 = (11)$	-0.4	0.2	0.8	$\mu s$
FH2 PHASE COMPARATOR (Pin 6)						
$I_{OUT}$	Output Current			100		$\mu A$
$\Delta I$	Current Ratio	Ratio of charging / discharging current (unsymmetry)		1		
VRET INTERFACE (Pin 3)						
	Polarity of VRET	Negative pulse, starts the vertical retrace	Negative			
$V_{TH}$	Threshold Voltage	$V_{CC} = 7.8V$ (threshold value derived from $V_{CC}$ )	2.7	3.0	3.3	V
$I_{IN}$	Input Current	Input Voltage : $0V < V_{VRET} < 7.8V$	-5		+5	$\mu A$

## VERTICAL DEFLECTION

VERTICAL LOGIC (countdown circuit for vertical deflection, 50/60Hz recognition and vertical oversize blanking)						
	Free Running Period	No $V\_Sync$ pulses (VRET) present		377		lines
	Search Window 60Hz		240		277	lines
VERTICAL OVERSIZE BLANKING (countdown circuit used also for vertical oversize blanking) (Pin 11)						
	Oversize Blanking Disable	$OV\_BLK\_VERT1,2 = (0,0)$ $SUB\_TITLE = 0$ ; there is no influence of 50 or 60Hz Mode (OBLK always low-level)	No Blanking			
	Vertical Oversize Blanking Subtitle Mode	$SUB\_TITLE = 1$ ; values are the blanked lines Input Frequency $f_{VRET} = 50Hz$ Input Frequency $f_{VRET} = 60Hz$	302 259		67 59	middle of line
	Vertical Oversize Blanking Zoom 1 Mode	$OV\_BLK\_VERT1,2 = (1,0)$ $SUB\_TITLE = 0$ ; values are the blanked lines Input Frequency $f_{VRET} = 50Hz$ Input Frequency $f_{VRET} = 60Hz$	285 239		49 43	middle of line
	Vertical Oversize Blanking Zoom 2 Mode	$OV\_BLK\_VERT1,2 = (1,1)$ $SUB\_TITLE = 0$ ; values are the blanked lines Input Frequency $f_{VRET} = 50Hz$ Input Frequency $f_{VRET} = 60Hz$	278 234		59 49	middle of line
	Vertical Oversize Blanking Blank Mode	$OV\_BLK\_VERT1,2 = (0,1)$ $SUB\_TITLE = 0$ ; there is no influence of 50 or 60Hz Mode (OBLK always high-level)	Full Blanking			

Notes : 3. Open collector output, polarity positive : High (high impedance) : oversize blanking  
Low (transistor pulled to Ground) : no blanking

2145-05.TBL

**ELECTRICAL CHARACTERISTICS** (continued) ( $V_{CC} = 7.8V$ ,  $T_{amb} = 25^{\circ}C$ , unless otherwise specified)

Symbol	Parameter	Test Conditions	Min.	Typ.	Max.	Unit
VERTICAL DEFLECTION (continued)						
VERTICAL RAMP GENERATOR (see Figure 2) (see Note 6)						
$V_{SAW}$	Sawtooth Amplitude	S_CORRECTION = 1111 Register V_AMPLITUDE				
	Min. Value	= minimum (0000000) value $V_{PP}$ for 190 lines difference	0.38	0.46	0.55	V
	Max. Value	= maximum (1111111) value $V_{PP}$ for 190 lines difference	1.11	1.16	1.21	V
$V_{MID}$	Sawtooth DC-Level	SUB_TITLE = 0				
	Nom. Value	Register V_DC = (10000) ; (no V-shift)		0		
	Min. Value	Register V_DC = (00000) ; (UP-shift)	55	65	75	mV
	Max. Value	Register V_DC = (11111) ; (DOWN-shift)	-75	-65	-55	mV
V_SUBTITLE (see Note 7)						
SUB_TITLE	Vertical DC-Shift for Subtitle Mode	Register SUB_TITLE = 1 (this value affects a vertical UP-shift of about 20 lines)	70	90	110	mV
VERTICAL S-CORRECTION (see Figure 3) (See Notes 4 and 5)						
$TF_{MID}$	Middle Fix Point	50Hz Mode ; measurement method : difference $SCO_{MAX} - SCO_{MIN}$ is measured at line 160 and 174 ; the middle line $TF_{MID}$ is calculated by linear interpolation (for 60Hz , the middle line shifts to line 140 ; not measured)	157	167	177	line
$\Delta VF_{UP}$ $\Delta VF_{LOW}$	Fix-Point Upper at line 72	50Hz Mode Difference $\Delta VF_{UP} = SCO_{MAX} - SCO_{MIN}$ measured at line 72 if V_AMPLITUDE = (1111111)		0		
	Lower at line 262	Difference $\Delta VF_{LOW} = SCO_{MAX} - SCO_{MIN}$ measured at line 262 if V_AMPLITUDE = (1111111)				
$\Delta V_{SAWMAX}$	Maximum Correction Voltage at line 127	50Hz Mode Difference $\Delta VF_{UP} = SCO_{MAX} - SCO_{MIN}$ measured at line 127 if V_AMPLITUDE = (1111111)	20	40	60	mV
	at line 207	Difference $\Delta VF_{LOW} = SCO_{MAX} - SCO_{MIN}$ measured at line 207 if V_AMPLITUDE = (1111111)	-60	-40	-20	mV
VERTICAL BREATHING (Pin 9) (Breathing effect $BR = 100\% * (V_{SAW} - V_{SAWB}) / V_{SAW}$ ) (see Notes 4 and 5) (see Figure 4)						
$BR_{Min}$ $BR_{Max}$	Breathing Effect					
	Min. Value Max. Value	$V_9 = 7.8V$ $V_9 = 1.5V$ measurement at line 72 and 262		0 5.3		% %
VERTICAL BRIDGE AND OUTPUT STAGE (see Figure 5)						
	Sense Input Voltage	Input Pins 16 and 15 - Differential input (see Note 2)				
	Min. Value Max. Value	$V_{14} \leq 3V$ $V_{14} \leq 5V$	10		20	V V
	Input Impedance (Pins 15-16)	Resistor value of the internal resistor-bridge		15		k $\Omega$
$I_{OUT}$	Output Current (Pin 14)	$V_{14} = 3V$ , $V_{16}$ and $V_{15} > 10V$		$\pm 100$		$\mu A$
$V_{OUT}$	Output Voltage (Pin 14)	$V_{16} > 10V$				
	Min. Value Max. Value			1 5		V V
$\Delta I_{OUT} / \Delta V_{IN}$	Transconductance (Pin 14)	Input voltage $\Delta V_{IN}$ = difference voltage between Pin 16 and Pin 15		0.5		mA/V

- Notes :**
- Parameter is not tested during production, but it is guaranteed by the design and qualified by means of corner lots.
  - Parameter is measured in EWS, with limits enlarged due to tester accuracy
  - Vertical output signals like vertical sawtooth, breathing and S-correction can only be measured via external test circuit (see Figure 10).
  - Voltage  $V_{SAW}$  only indirectly measurable via application circuit in closed loop condition (voltage-drop across  $R_{SENS}$ ) for all vertical functions : see Note 5.
  - DC-shift of internal sawtooth-voltage; thus maintenance of fix-points for EW-Parabola and S-CORRECTION

**ELECTRICAL CHARACTERISTICS** (continued) ( $V_{CC} = 7.8V$ ,  $T_{amb} = 25^{\circ}C$ , unless otherwise specified)

Symbol	Parameter	Test Conditions	Min.	Typ.	Max.	Unit
VERTICAL DEFLECTION (continued)						
EAST-WEST CORRECTION (Pins 13-12) (See Figure 6)						
	Output-Current			-2.5 to +3		mA
	Output Voltage Range	Application : Output Darlington-Transistor		-0.5 to +2		V
$V_{PAR}$	Parabola Amplitude	See Figure 7 $H\_WIDTH = (000000)$ , $EW\_TILT = (10000)$ , $EW\_SHAPE = (1111)$				
	$EW\_LOW = 0$ Max. Value Min. Value	$EW\_AMPLITUDE = (00000)$ $EW\_AMPLITUDE = (11111)$ , (Parabola = 1/3)	0.63 0.21	0.75 0.27	0.87 0.33	$V_{PP}$ $V_{PP}$
	$EW\_LOW = 1$ Max. Value Min. Value	$EW\_AMPLITUDE = (00000)$ $EW\_AMPLITUDE = (11111)$	0.41	0.48 0	0.56	$V_{PP}$ $V_{PP}$
$\Delta V_{PAR}$	Parabola Amplitude Ratio ( $EW\_LOW = 0$ )	$\Delta V_{PAR} = V_{PAR} (EW\_AMPLITUDE) = (00000) / V_{PAR} (EW\_AMPLITUDE) = (11111)$	2.4	3	3.5	
$V_{DC-MIN}$ $V_{DC-MAX}$	Parabola DC Min. Value Max. Value	$EW\_TILT = (10000)$ , $EW\_SHAPE = (1111)$ , $EW\_LOW = 0$ , $EW\_AMPLITUDE = (10000)$ Register $H\_WIDTH = (000000)$ (min. picture width) Register $H\_WIDTH = (111111)$ (max. picture width)	2.4 3.65	2.65 3.8	2.9 3.95	V V
TILT	Parabola Unsymmetry (see Figure 8) Max. Value Min. Value	Value is ratio between upper and lower parabola value. $TILT = V_{PARUP} / V_{PARLOW}$ $H\_WIDTH = (000000)$ , $EW\_SHAPE = (1111)$ , $EW\_LOW = 0$ , $EW\_AMPLITUDE = (10000)$ Register $EW\_TILT = (11111)$ Register $EW\_TILT = (00000)$		1.83 0.55		
$R_{MAX}$ $R_{MIN}$	Parabola Shape Deformation (see Figure 9) Max. Value Min. Value	$R = V_{DEF} / V_{PAR}$ $H\_WIDTH = (000000)$ , $EW\_TILT = (10000)$ , $EW\_LOW = 0$ , $EW\_AMPLITUDE = (00000)$ Register $EW\_SHAPE = (0000)$ Register $EW\_SHAPE = (1111)$ (no parabola deformation), $V\_AMPLITUDE = (1111111)$		0.07 0		

2145-07.TBL

Figure 1

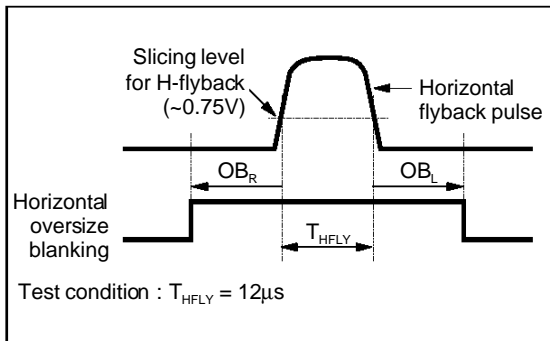

2145-03.EPS

Figure 2

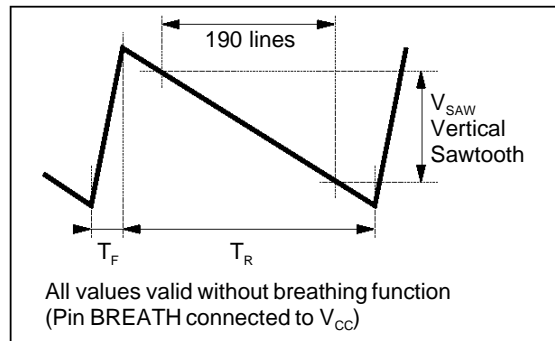

2145-04.EPS

Figure 3

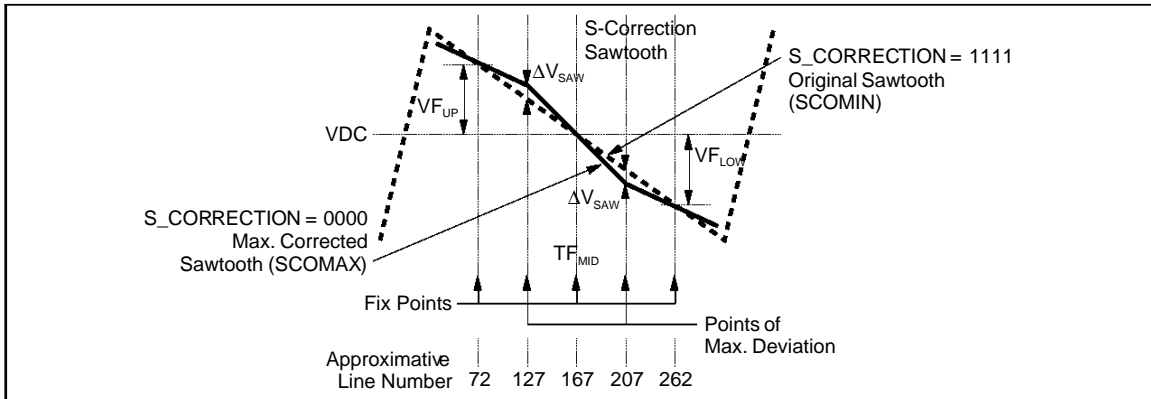

2145-05.EPS

Figure 4

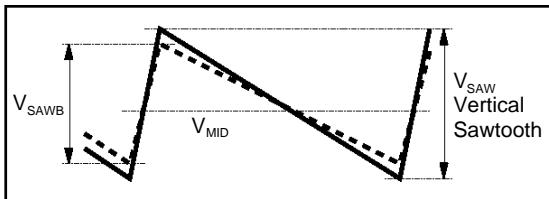

2145-06.EPS

Figure 6

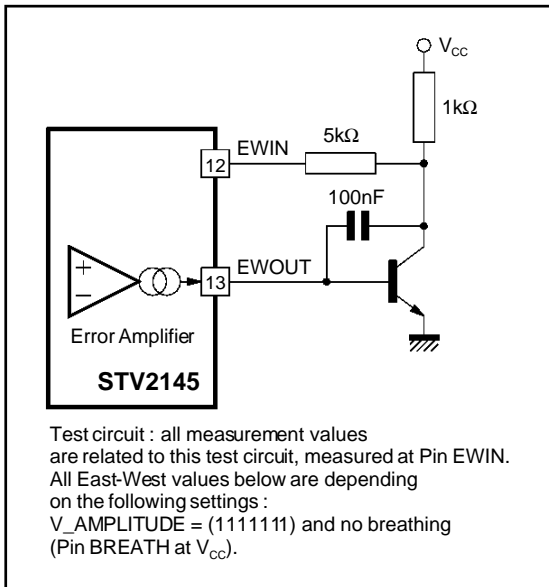

2145-08.EPS

Figure 5

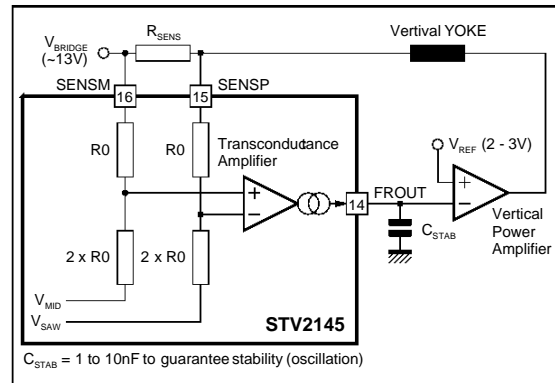

2145-07.EPS

Figure 7

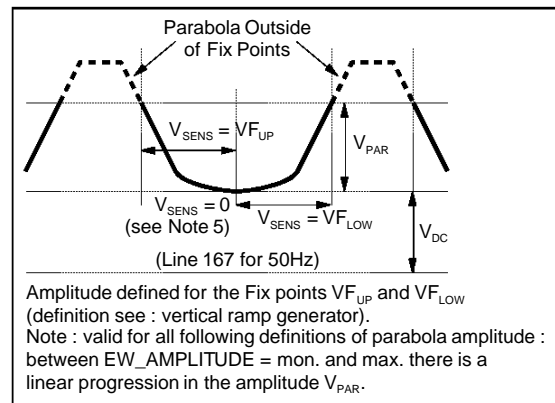

2145-08.EPS

Figure 8

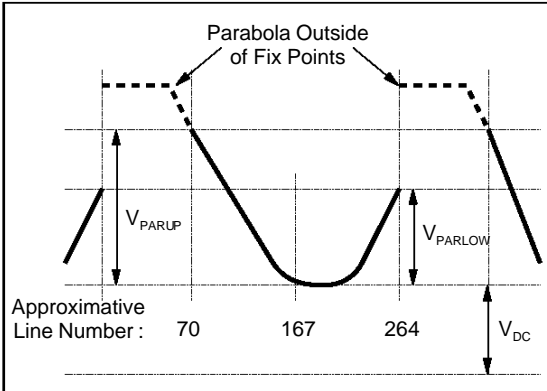

Figure 9

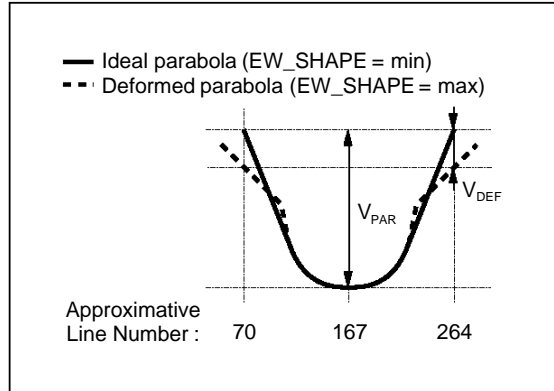
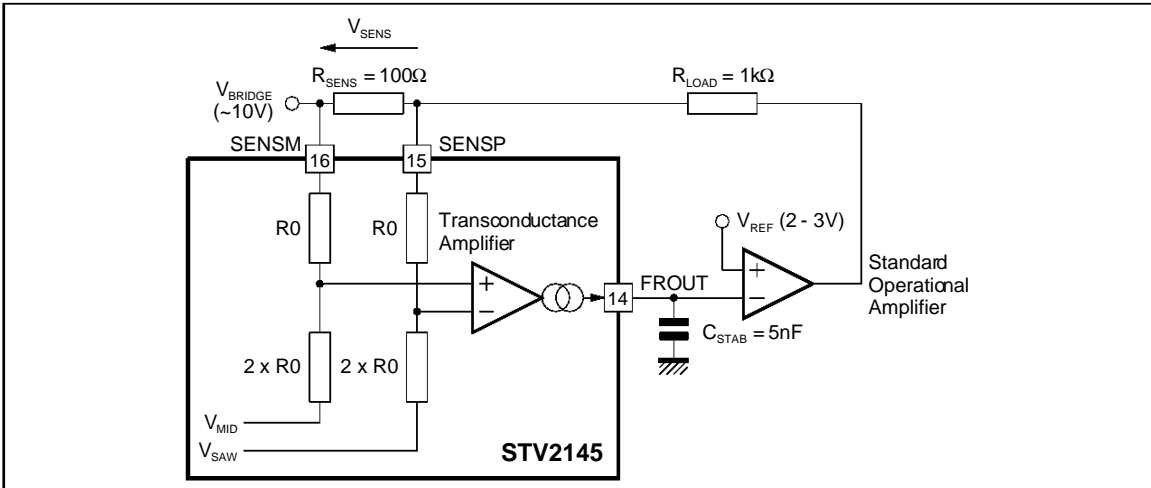
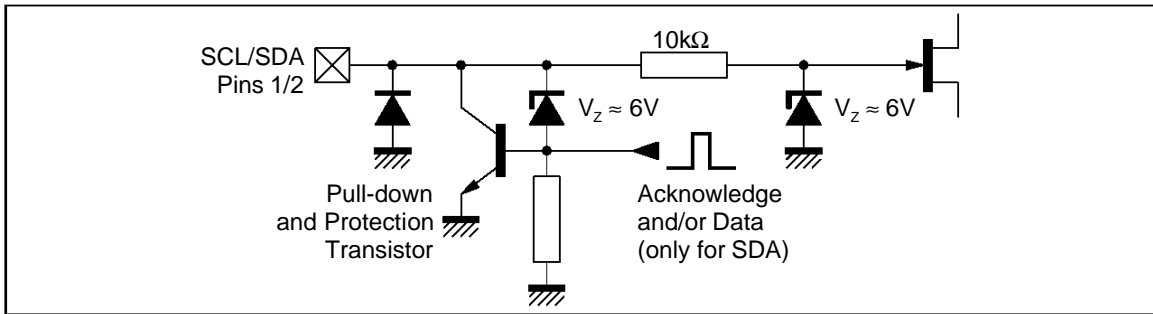

Figure 10



INPUTS/OUTPUTS PIN CONFIGURATION

Figure 11



2145-13.EPS

Figure 12

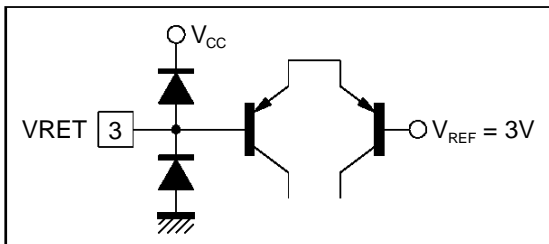

2145-14.EPS

Figure 13

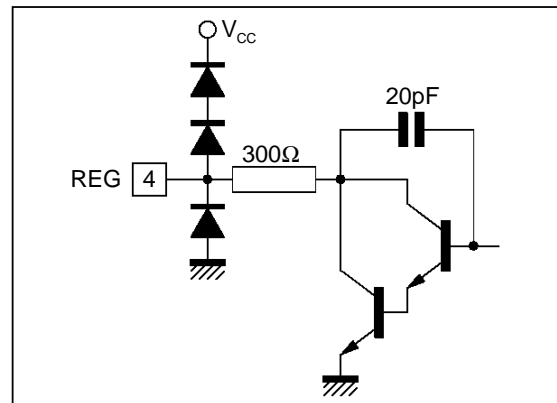

2145-15.EPS

Figure 14

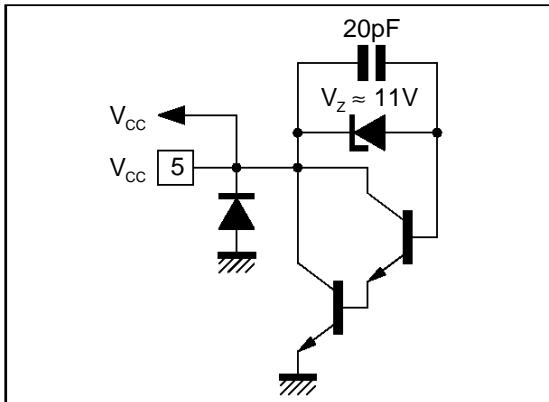

2145-16.EPS

Figure 15

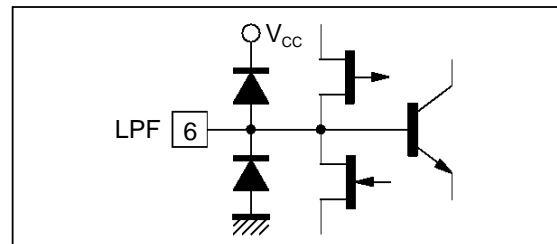

2145-17.EPS

Figure 16

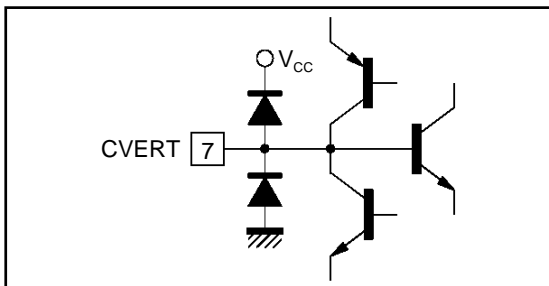

2145-18.EPS

Figure 17

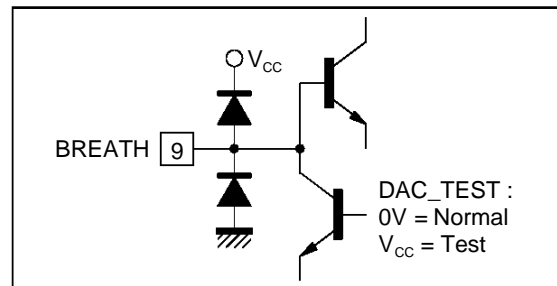

2145-19.EPS

INPUTS/OUTPUTS PIN CONFIGURATION (continued)

Figure 18

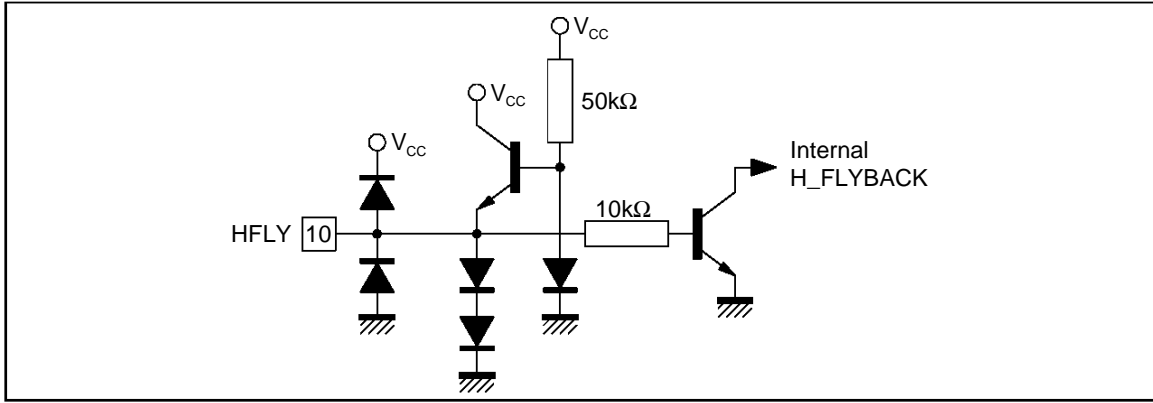

2145-20.EPS

Figure 19

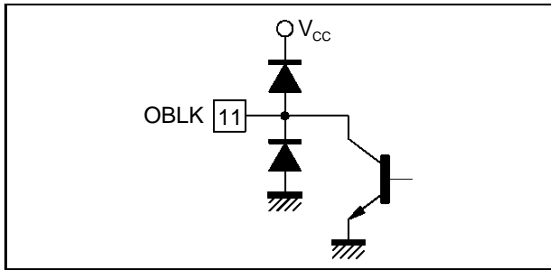

2145-21.EPS

Figure 20

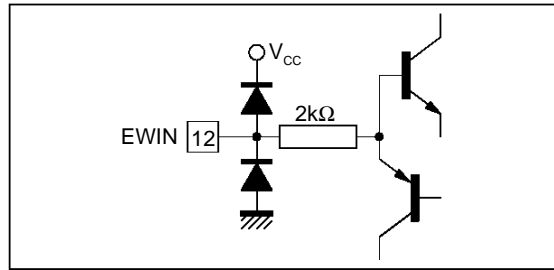

2145-22.EPS

Figure 21

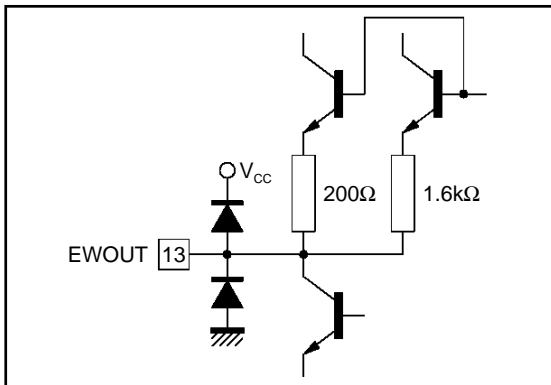

2145-23.EPS

Figure 22

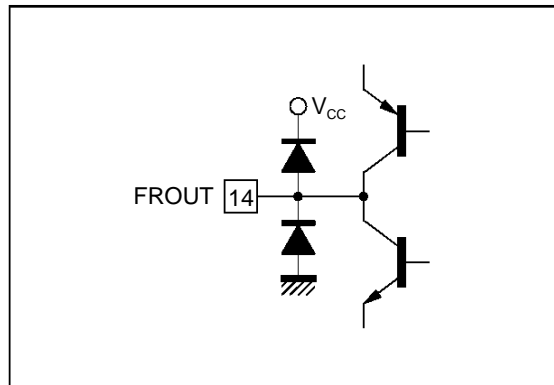

2145-24.EPS

INPUTS/OUTPUTS PIN CONFIGURATION (continued)

Figure 23

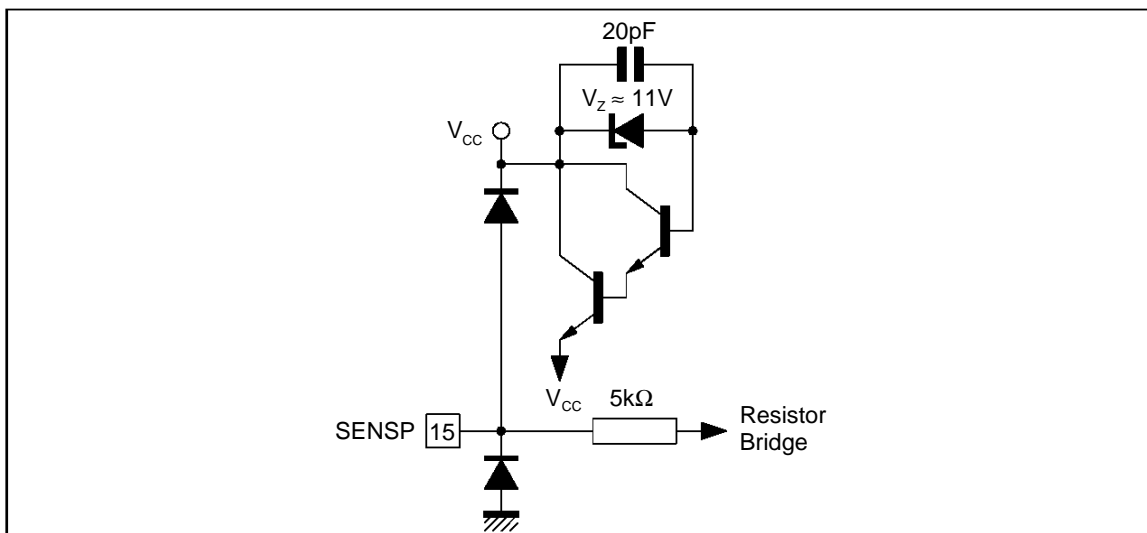

2145-215.EPS

Figure 24

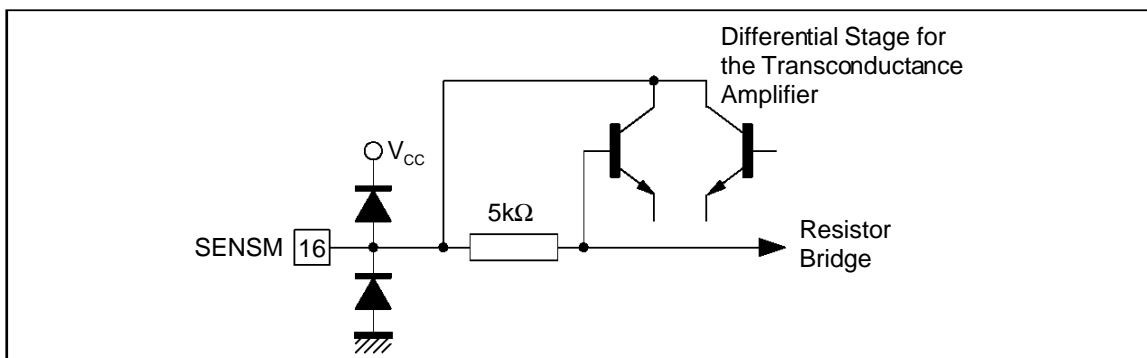

2145-216.EPS

TYPICAL APPLICATION

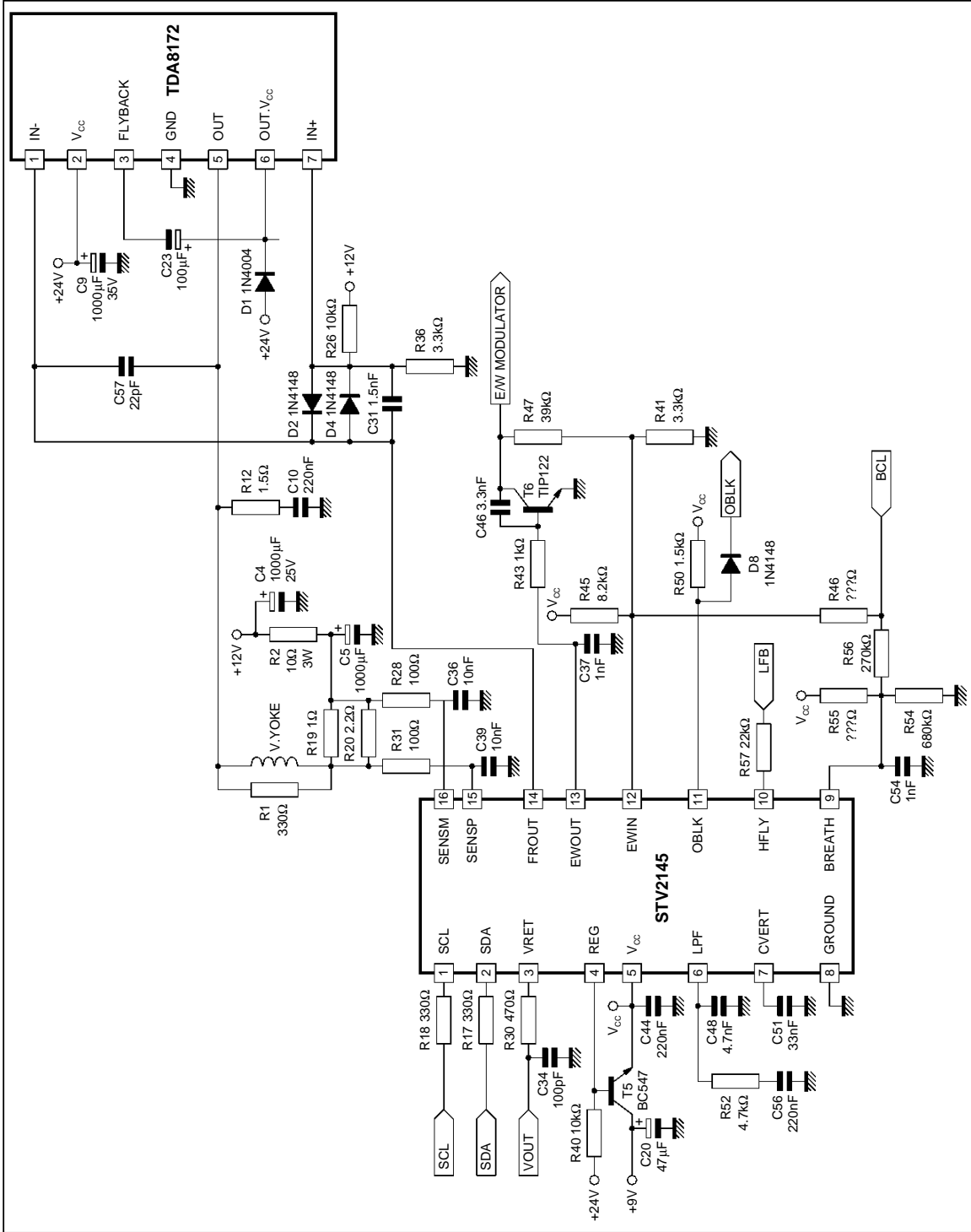

2145-27.EPS

**PACKAGE MECHANICAL DATA**  
16 PINS - PLASTIC PACKAGE

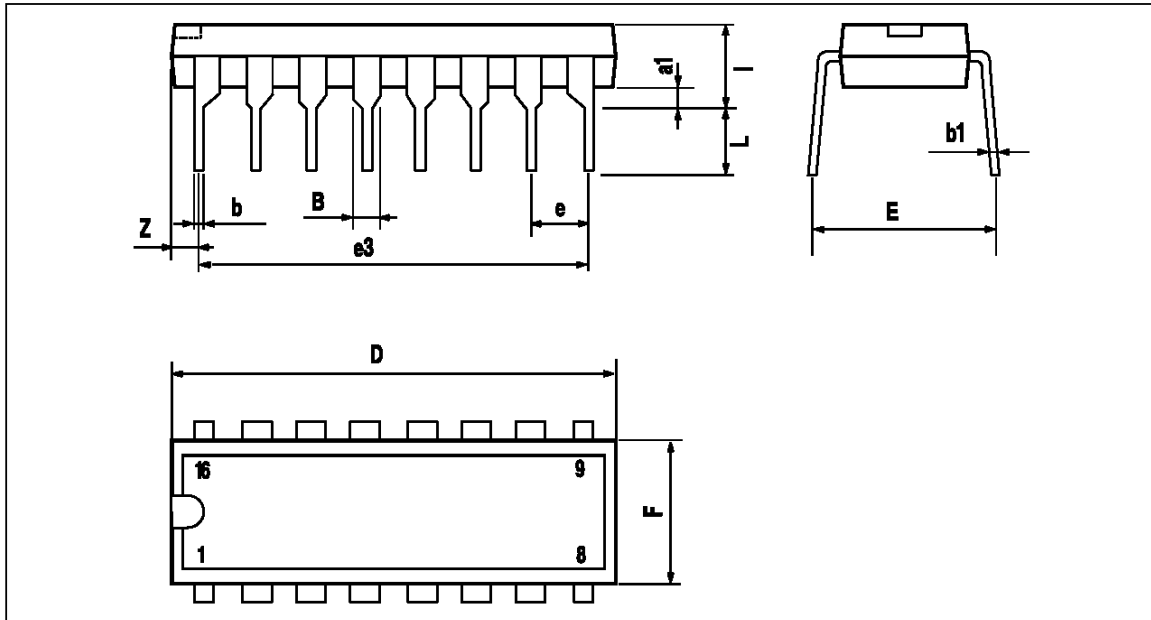

PM-DIP16.EPS

Dimensions	Millimeters			Inches		
	Min.	Typ.	Max.	Min.	Typ.	Max.
a1	0.51			0.020		
B	0.77		1.65	0.030		0.065
b		0.5			0.020	
b1		0.25			0.010	
D			20			0.787
E		8.5			0.335	
e		2.54			0.100	
e3		17.78			0.700	
F			7.1			0.280
I			5.1			0.201
L		3.3			0.130	
Z			1.27			0.050

DIP16.TBL

Information furnished is believed to be accurate and reliable. However, SGS-THOMSON Microelectronics assumes no responsibility for the consequences of use of such information nor for any infringement of patents or other rights of third parties which may result from its use. No licence is granted by implication or otherwise under any patent or patent rights of SGS-THOMSON Microelectronics. Specifications mentioned in this publication are subject to change without notice. This publication supersedes and replaces all information previously supplied. SGS-THOMSON Microelectronics products are not authorized for use as critical components in life support devices or systems without express written approval of SGS-THOMSON Microelectronics.

© 1996 SGS-THOMSON Microelectronics - All Rights Reserved

Purchase of  $\mu$ C Components of SGS-THOMSON Microelectronics, conveys a license under the Philips  $\mu$ C Patent. Rights to use these components in a  $\mu$ C system, is granted provided that the system conforms to the  $\mu$ C Standard Specifications as defined by Philips.

SGS-THOMSON Microelectronics GROUP OF COMPANIES

Australia - Brazil - China - France - Germany - Hong Kong - Italy - Japan - Korea - Malaysia - Malta - Morocco  
The Netherlands - Singapore - Spain - Sweden - Switzerland - Taiwan - Thailand - United Kingdom - U.S.A.