

HIGH SIDE DRIVER

ADVANCE DATA

- 25A PEAK OUTPUT CURRENT
- $R_{ON} = 100m\Omega$
- DIAGNOSTIC AND PROTECTION FUNCTIONS
- μP COMPATIBLE
- GROUNDED CASE
- INRUSH CURRENT LIMITING CIRCUIT

DESCRIPTION

The L9821 High Side Driver realized with Multipower - BCD mixed technology, drives resistive or inductive loads with one side connected to ground.

The input control is TTL compatible and a diagnostic output provides an indication of load (open and short) and device status (thermal and overvoltage shutdown). On chip thermal protection and short circuit protection are provided.

MULTIPOWER BCD TECHNOLOGY

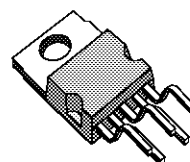

Pentawatt

ORDERING NUMBER : L9821

The device is assembled in the Pentawatt package with the tab connected to the ground terminal.

BLOCK DIAGRAM

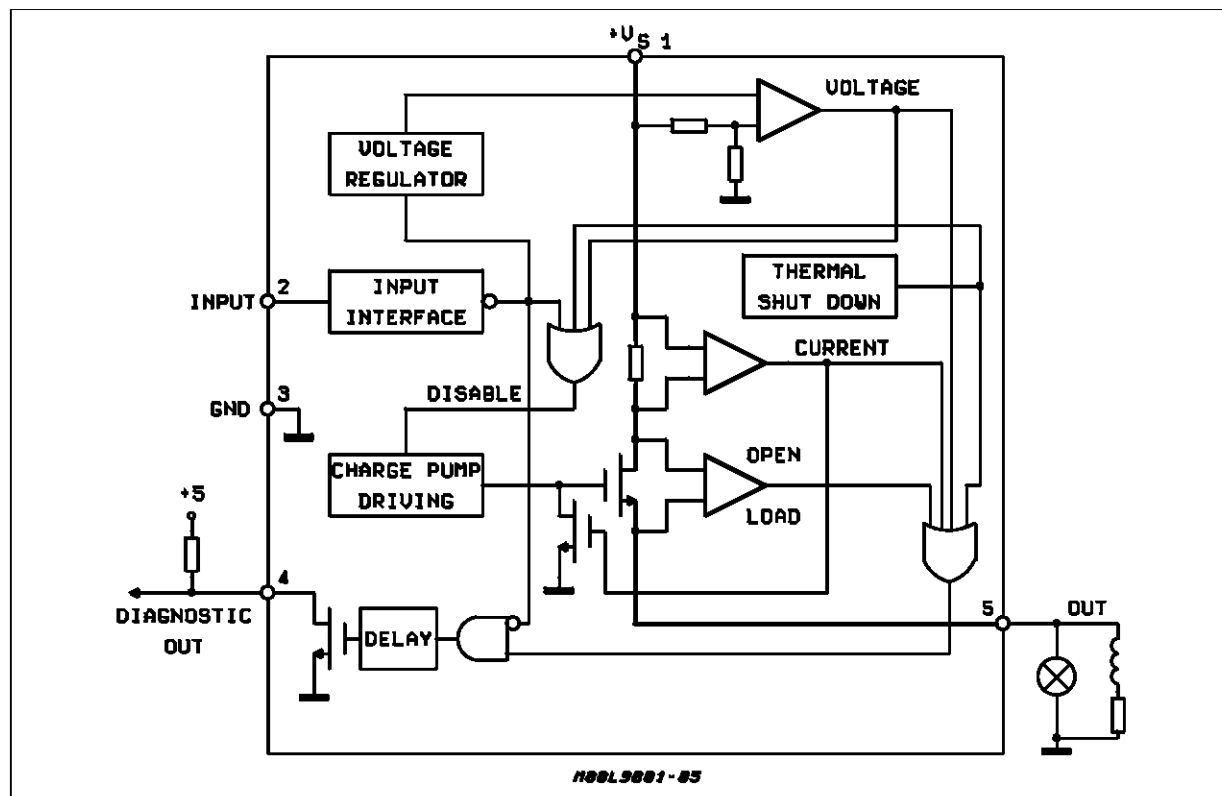

ABSOLUTE MAXIMUM RATINGS

Symbol	Parameter	Value
V _S	Max Forward Voltage	50Vdc
	Positive Transient Peak Voltage (dump : τ _f fall time constant = 100ms, 5ms ≤ t _{rise} ≤ 10ms, R _{source} ≥ 0.5Ω) – Resistive Load – Inductive Load	60V 50V (*)
	Reverse Input Voltage	– 0.3Vdc
V ₁ V ₄ V ₅	Input Voltage Pin 2 (to GND) Pin 4 Voltage Pin 5 Voltage (to GND) (to GND)	– 0.3V / + V _S (V _S < 20V) – 0.3V / + V _S (V _S < 20V) – 3V / + V _S (V _S < 20V)
I ₁ I ₂ I ₄ I ₅	Pin 1 Current Pin 2 Current (forced) Pin 4 Current (sink) Pin 5 Current	Internally Limited 0.5mA 10mA Internally Limited
P _{TOT}	Power Dissipation	Internally Limited
T _J , T _{STG}	Junction and Storage Temperature Range	– 55°C to + 150°C

* due to the negative voltage at the output during the switching off.

THERMAL DATA

Symbol	Parameter	Value	Unit
R _{th j-case}	Thermal Resistance Junction-case	Max 1.5	°C/W

PIN CONNECTION (top view)

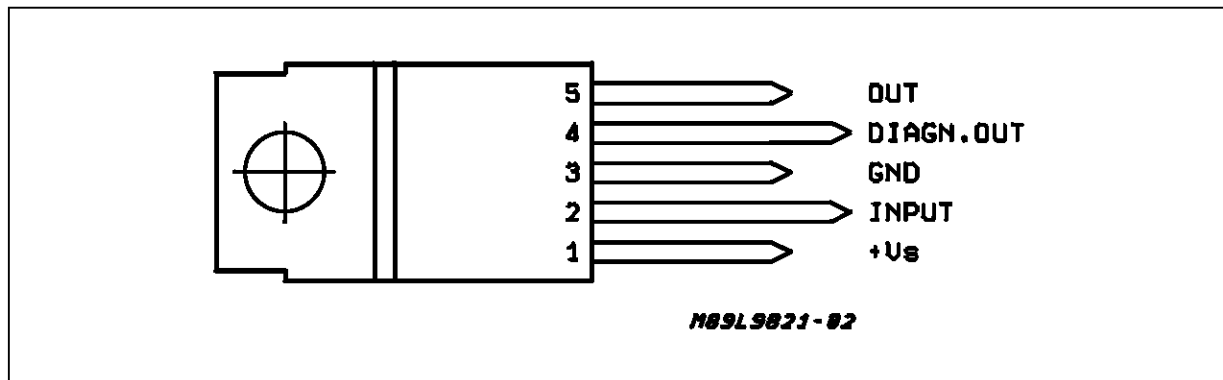

PIN FUNCTIONS

1. POWER SUPPLY

Supply voltage input. When the supply reaches the maximum operating voltage (32V) the device is turned off, protecting itself and the load. Turning off guaranteed for $V_S > 41V$.

2. INPUT

TTL compatible input. High level on this pin means output current ON. The low level voltage switches off the charge pump, the power stage and the diagnostic output reducing to the minimum value the quiescent current.

3. GROUND

This pin must be connected to ground.

4. DIAGNOSTIC FEEDBACK

The diagnostic circuit is active in input high level

condition. This output detects with Typically 45ms delay at $T_{amb} = 25^{\circ}C$ the following faults :

- Overvoltage condition.
- Thermal shutdown.
- Short circuit. The power stage current is internally limited at 25A.
- Open load. The open load condition is detected with load current $< 0.6A$.

The diagnostic output is active low. The diagnostic delay time allows to avoid spurious diagnosis (i.e : turn ON overcurrent, overvoltage spikes etc.).

5. POWER OUTPUT

The device is provided with short circuit protection.

ELECTRICAL CHARACTERISTICS ($V_S = 14.4V$; $-40^{\circ}C \leq T_j \leq 125^{\circ}C$, unless otherwise specified)

Symbol	Parameter	Test Condition	Min.	Typ.	Max.	Unit
V_{OP}	Operat. Voltage		6		32	V
R_{ON}	On Resistance	Input $>2V$: $T_j = 25^{\circ}C$ Input $>2V$: Full T range		0.1	0.2	Ω
I_{SC}	Short circuit current			25		A
I_{DL}	Over Current Detection Level			20		A
I_{OPD}	Open Load Detection Level	Device ON			1.2	A
V_{clamp}	Output Under Voltage Clamping	$I_{load} < 6A$ Inductive	-12		-4	V
I_{off}	Off State Supply Current	$T_j = -40$ to $35^{\circ}C$ $T_j = 35$ to $85^{\circ}C$			100 300	μA μA
I_{ON}	ON State Supply Current	$T_j = 25^{\circ}C$		10		mA
V_{IL}	Input Low Level				0.8	V
V_{IH}	Input High Level		2.0			V
I_i	Input Current	$V_i = V_{threshold}$			15	μA
I_{LEAKD}	Diagnostic Output Leakage Voltage	$V_{CC} = 5V$ Diagnostic Output			10	μA
V_{SATD}	Diagnostic Output Saturation Voltage	$I_{sink} < 1.6mA$			0.4	V
T_{Dd}	Diagnostic Delay Time	$T_j = 25^{\circ}C$;		45		ms
t_{dON}	Output ON Delay Time	$T_j = 25^{\circ}C$		15		μs
t_r	Output ON Rise Time	$T_j = 25^{\circ}C$		65		μs
t_{dOFF}	Output OFF Delay Time	$T_j = 25^{\circ}C$		50		μs
t_f	Output OFF Fall Time	$T_j = 25^{\circ}C$		100		μs

FUNCTIONAL DESCRIPTION

The L9821 is a high side drive monolithic switch, driven by TTL, CMOS input logic, able to supply resistive or inductive loads up to 6A DC allowing a current peak of 25A with a $R_{DS(ON)} = 0.1$. The electronic switch, in addition to its main function, protects itself, the power network and the load against load dump (up to 60V) and overload and it detects short circuit, open load and overtemperature conditions. All these functions (logic control and power actuation) are possible on a single chip thanks to the new mixed ST Multipower BCD technology that allows to integrate isolated DMOS power transistors in combination with Bipolar and CMOS signal structures on the same chip.

The high side drive connection (series switch between the load and the positive power source) is particularly suited in automotive environment where the electrochemical corrosion withstanding has primary importance. For this connection the best solution is a Power MOS N-channel which requires for driving only a capacitive charge pump completely integrated on the switch chip.

The L9821 is based on a power DMOS series element, a driving circuit with a charge pump, an input logic interface and on some protection and fault detection circuits.

The power DMOS transistor has a $R_{DS(ON)} = 0.1\Omega$ (typ. value @ $T_J = 25^\circ\text{C}$, $V_{GS} = 10\text{V}$). The low value of $R_{DS(ON)}$ is important both to increase the power transferred to the load and to minimize the power dissipated in the device.

The charge pump is a capacitive voltage tripler starting from power supply (car battery), driven by a 500kHz oscillator.

The input interface is based on a circuitry solution able to guarantee the stability over temperature of the TTL logic levels and very low quiescent current in OFF condition.

When the supply reaches the maximum operating voltage (32V) the device is turned OFF, protecting itself and the load ; moreover local zener clamps are provided in some critical points to avoid that V_{GS} of

any MOS transistor could reach dangerous values even during 60V load dump transient.

The inrush current limiting is a significant feature of the L9821. This function allows to protect the power supply network and may extend the life of the loads. For example, in the case of the lamps, the tungsten wire resistance value in cold condition is about one tenth of the nominal steady state and then the inrush current during the turn on is statistically one of the main causes of lamps failures. If the high current condition persists (e.g. load short circuit) and the junction temperature rises above 150°C , the thermal protection circuit turns off the device preventing any damage. The current limiting and the thermal shutdown are sufficient to protect the device against any overload because the power DMOS has not the second breakdown.

When the L9821 is driven and one of the protections (overtemperature, overvoltage, overload) is present, a fault detection open drain output turns on. This output is active also when I_{load} is lower than 0.6A detecting the open load (disconnected or burned out). The diagnostic output detects fault conditions with 25ms delay in order to avoid spurious diagnosis (i.e. : turn on overcurrent, overvoltage spikes etc.). In OFF conditions the fault detection circuits are not active to allow a minimum quiescent current.

The device can drive unipolar DC motors and solenoids as well because it can recirculate an inductive current when the output voltage goes lower than V_{clamp} value (typically - 6.5V in respect to ground). The possibility to have a start up current is useful also for DC motors allowing the maximum starting torque.

TYPICAL APPLICATION OF THE L9821

The L9821 integrated high side driver can be used to replace an electromechanical relay.

Inductive load (i.e. solenoids, motors) can be driven by the L9821. No external components are required for the coil current recirculation, because the device provides this function internally.

Figure 1.

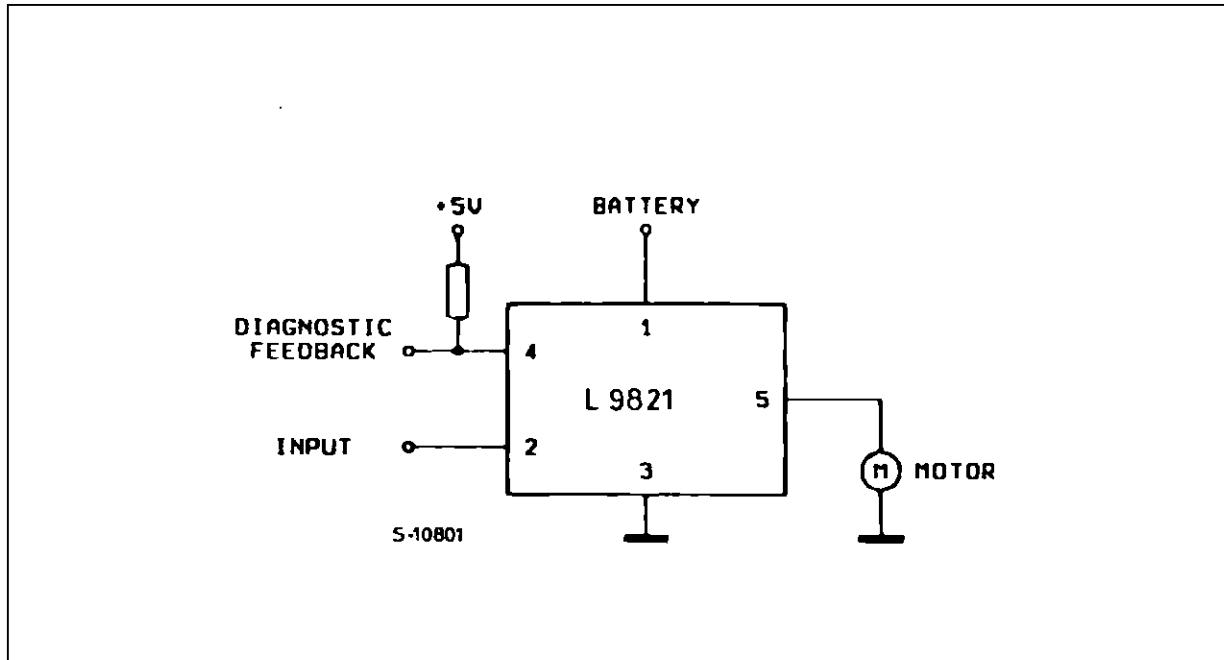

PENTAWATT PACKAGE MECHANICAL DATA

DIM.	mm			inch		
	MIN.	TYP.	MAX.	MIN.	TYP.	MAX.
A			4.8			0.189
C			1.37			0.054
D	2.4		2.8	0.094		0.110
D1	1.2		1.35	0.047		0.053
E	0.35		0.55	0.014		0.022
F	0.8		1.05	0.031		0.041
F1	1		1.4	0.039		0.055
G		3.4		0.126	0.134	0.142
G1		6.8		0.260	0.268	0.276
H2			10.4			0.409
H3	10.05		10.4	0.396		0.409
L		17.85			0.703	
L1		15.75			0.620	
L2		21.4			0.843	
L3		22.5			0.886	
L5	2.6		3	0.102		0.118
L6	15.1		15.8	0.594		0.622
L7	6		6.6	0.236		0.260
M		4.5			0.177	
M1		4			0.157	
Dia	3.65		3.85	0.144		0.152

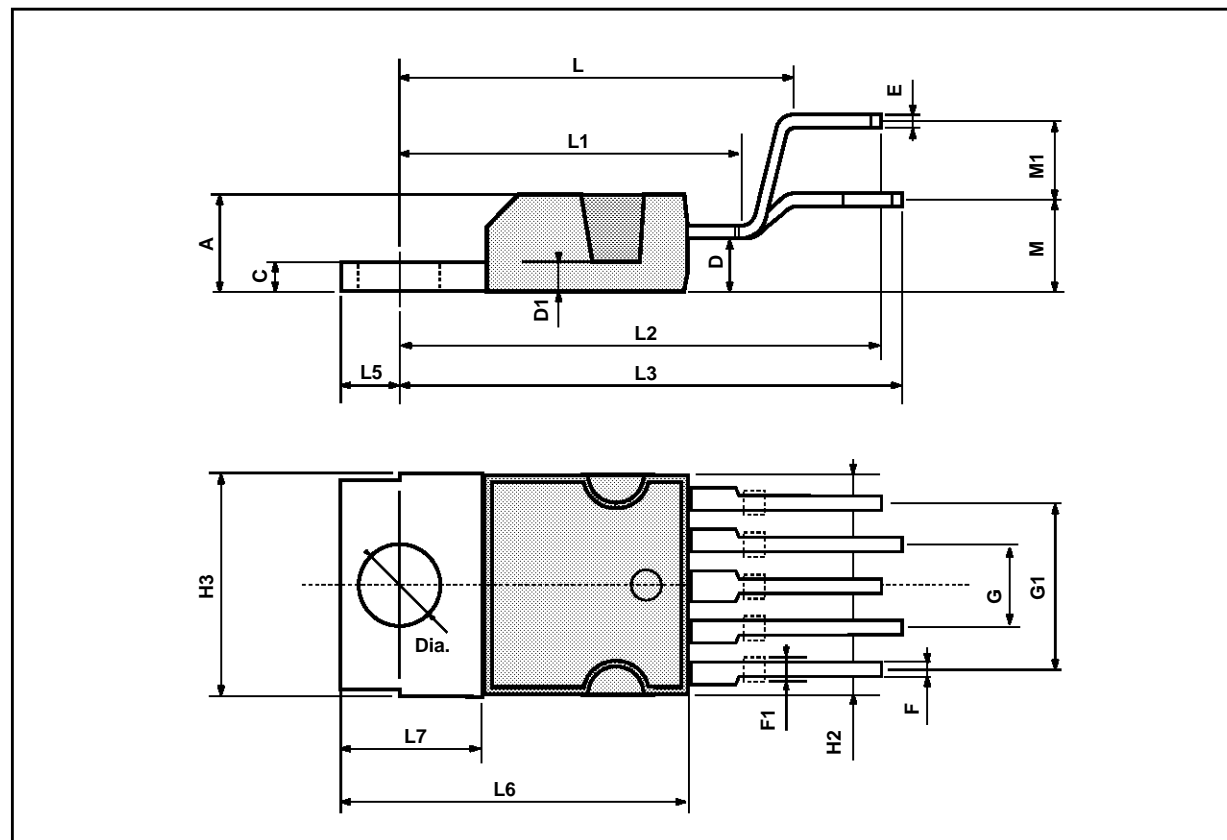

Information furnished is believed to be accurate and reliable. However, SGS-THOMSON Microelectronics assumes no responsibility for the consequences of use of such information nor for any infringement of patents or other rights of third parties which may result from its use. No license is granted by implication or otherwise under any patent or patent rights of SGS-THOMSON Microelectronics. Specifications mentioned in this publication are subject to change without notice. This publication supersedes and replaces all information previously supplied. SGS-THOMSON Microelectronics products are not authorized for use as critical components in life support devices or systems without express written approval of SGS-THOMSON Microelectronics.

© 1994 SGS-THOMSON Microelectronics - All Rights Reserved
PENTAWATT® is a Registered Trademark of SGS-THOMSON Microelectronics

SGS-THOMSON Microelectronics GROUP OF COMPANIES
Australia - Brazil - France - Germany - Hong Kong - Italy - Japan - Korea - Malaysia - Malta - Morocco - The Netherlands - Singapore - Spain - Sweden - Switzerland - Taiwan - Thailand - United Kingdom - U.S.A.