

CMOS Video Speed, 8-Bit, 50 MSPS, R2R D/A Converters

The CA3338 family are CMOS/SOS high speed R2R voltage output digital-to-analog converters. They can operate from a single +5V supply, at video speeds, and can produce "rail-to-rail" output swings. Internal level shifters and a pin for an optional second supply provide for an output range below digital ground. The data complement control allows the inversion of input data while the latch enable control provides either feedthrough or latched operation. Both ends of the R2R ladder network are available externally and may be modulated for gain or offset adjustments. In addition, "glitch" energy has been kept very low by segmenting and thermometer encoding of the upper 3 bits.

The CA3338 is manufactured on a sapphire substrate to give low dynamic power dissipation, low output capacitance, and inherent latch-up resistance.

Ordering Information

PART NUMBER	LINEARITY (INL, DNL)	TEMP. RANGE (°C)	PACKAGE	PKG. NO.
CA3338E	±1.0 LSB	-40 to 85	16 Ld PDIP	E16.3
CA3338AE	±0.75 LSB	-40 to 85	16 Ld PDIP	E16.3
CA3338M	±1.0 LSB	-40 to 85	16 Ld SOIC	M16.3
CA3338AM	±0.75 LSB	-40 to 85	16 Ld SOIC	M16.3

Features

- CMOS/SOS Low Power
- R2R Output, Segmented for Low "Glitch"
- CMOS/TTL Compatible Inputs
- Fast Settling: (Typ) to $1/2$ LSB 20ns
- Feedthrough Latch for Clocked or Unclocked Use
- Accuracy (Typ) ±0.5 LSB
- Data Complement Control
- High Update Rate (Typ) 50MHz
- Unipolar or Bipolar Operation

Applications

- TV/Video Display
- High Speed Oscilloscope Display
- Digital Waveform Generator
- Direct Digital Synthesis

Pinout

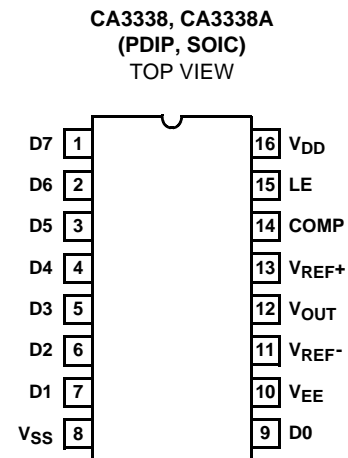

Functional Diagram

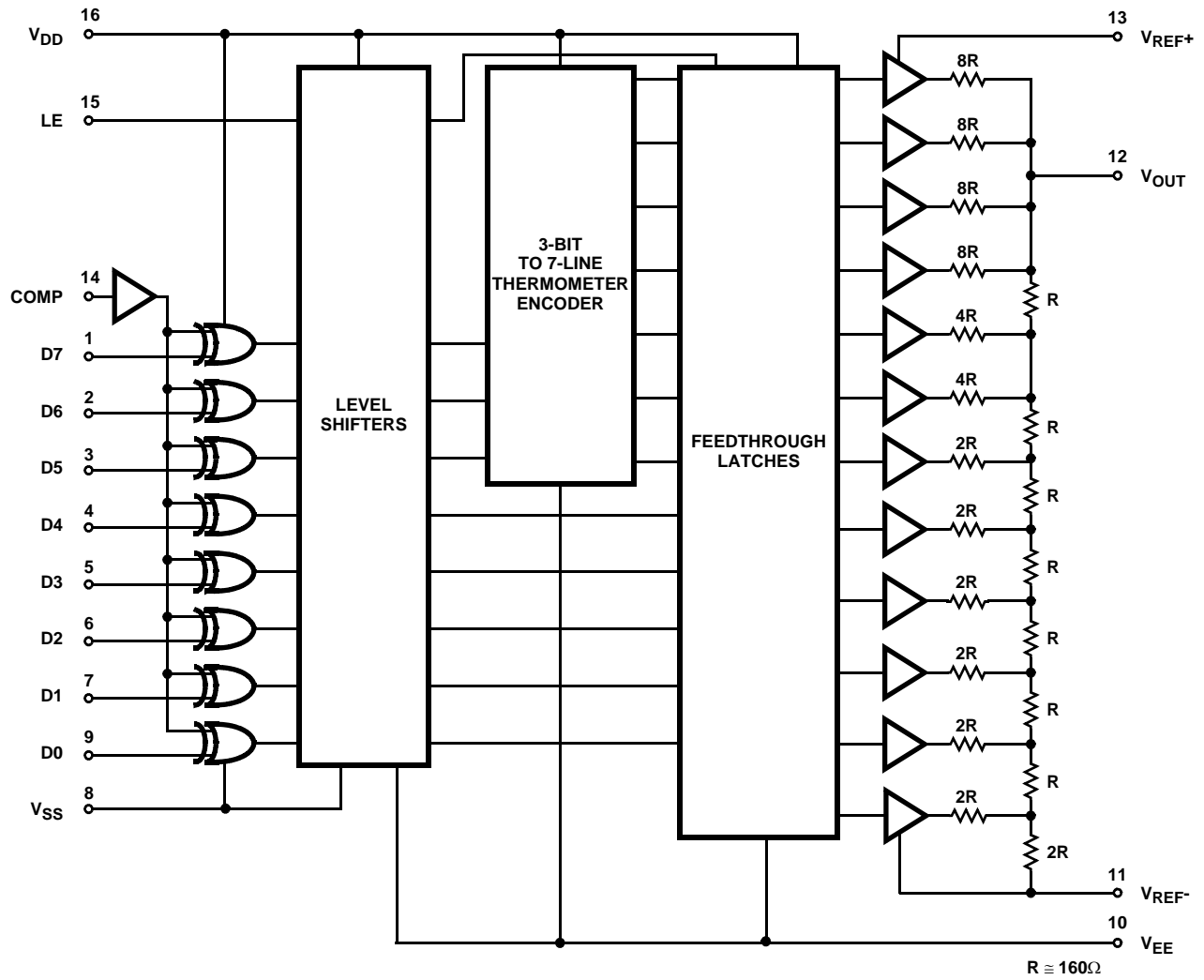

CA3338, CA3338A

Absolute Maximum Ratings

DC Supply-Voltage Range -0.5V to +8V
 ($V_{DD} - V_{SS}$ or $V_{DD} - V_{EE}$, Whichever is Greater)
 Input Voltage Range
 Digital Inputs (LE, COMP D0 - D7) $V_{SS} - 0.5V$ to $V_{DD} + 0.5V$
 Analog Pins (V_{REF+} , V_{REF-} , V_{OUT}) $V_{DD} - 8V$ to $V_{DD} + 0.5V$
 DC Input Current
 Digital Inputs (LE, COMP, D0 - D7) $\pm 20mA$
 Recommended Supply Voltage Range 4.5V to 7.5V

Thermal Information

Thermal Resistance (Typical, Note 1) θ_{JA} ($^{\circ}C/W$) θ_{JC} ($^{\circ}C/W$)
 PDIP Package 90 N/A
 SOIC Package 100 N/A
 Maximum Junction Temperature
 Plastic Packages $150^{\circ}C$
 Maximum Storage Temperature Range, T_{STG} $-65^{\circ}C$ to $150^{\circ}C$
 Maximum Lead Temperature (Soldering 10s) $300^{\circ}C$
 (SOIC - Lead Tips Only)

Operating Conditions

Temperature Range (T_A)
 Plastic Package, E suffix, M suffix $-40^{\circ}C$ to $85^{\circ}C$

CAUTION: Stresses above those listed in "Absolute Maximum Ratings" may cause permanent damage to the device. This is a stress only rating and operation of the device at these or any other conditions above those indicated in the operational sections of this specification is not implied.

NOTE:

- θ_{JA} is measured with the component mounted on an evaluation PC board in free air.

Electrical Specifications $T_A = 25^{\circ}C$, $V_{DD} = 5V$, $V_{REF+} = 4.608V$, $V_{SS} = V_{EE} = V_{REF-} = GND$, LE Clocked at 20MHz, $R_L \geq 1 M\Omega$, Unless Otherwise Specified

PARAMETER	TEST CONDITIONS	MIN	TYP	MAX	UNITS
ACCURACY					
Resolution		8	-	-	Bits
Integral Linearity Error	See Figure 4				
CA3338		-	-	± 1	LSB
CA3338A		-	-	± 0.75	LSB
Differential Linearity Error	See Figure 4				
CA3338		-	-	± 0.75	LSB
CA3338A		-	-	± 0.5	LSB
Gain Error	Input Code = FF _{HEX} , See Figure 3				
CA3338		-	-	± 0.75	LSB
CA3338A		-	-	± 0.5	LSB
Offset Error	Input Code = 00 _{HEX} ; See Figure 3	-	-	± 0.25	LSB
DIGITAL INPUT TIMING					
Update Rate	To Maintain $1/2$ LSB Settling	DC	50	-	MHz
Update Rate	$V_{REF-} = V_{EE} = -2.5V$, $V_{REF+} = +2.5V$	DC	20	-	MHz
Set Up Time t_{SU1}	For Low Glitch	-	-2	-	ns
Set Up Time t_{SU2}	For Data Store	-	8	-	ns
Hold Time t_H	For Data Store	-	5	-	ns
Latch Pulse Width t_W	For Data Store	-	5	-	ns
Latch Pulse Width t_W	$V_{REF-} = V_{EE} = -2.5V$, $V_{REF+} = +2.5V$	-	25	-	ns
OUTPUT PARAMETERS R_L Adjusted for 1V _{P-P} Output					
Output Delay t_{D1}	From LE Edge	-	25	-	ns
Output Delay t_{D2}	From Data Changing	-	22	-	ns
Rise Time t_r	10% to 90% of Output	-	4	-	ns
Settling Time t_S	10% to Settling to $1/2$ LSB	-	20	-	ns
Output Impedance	$V_{REF+} = 6V$, $V_{DD} = 6V$	120	160	200	Ω
Glitch Area		-	150	-	pV/s
Glitch Area	$V_{REF-} = V_{EE} = -2.5V$, $V_{REF+} = +2.5V$	-	250	-	pV/s

CA3338, CA3338A

Electrical Specifications $T_A = 25^\circ\text{C}$, $V_{DD} = 5\text{V}$, $V_{REF+} = 4.608\text{V}$, $V_{SS} = V_{EE} = V_{REF-} = \text{GND}$, LE Clocked at 20MHz, $R_L \geq 1\text{M}\Omega$, Unless Otherwise Specified **(Continued)**

PARAMETER	TEST CONDITIONS	MIN	TYP	MAX	UNITS
REFERENCE VOLTAGE					
V_{REF+} Range	(+) Full Scale, Note 2	$V_{REF-} + 3$	-	V_{DD}	V
V_{REF-} Range	(-) Full Scale, Note 2	V_{EE}	-	$V_{REF+} - 3$	V
V_{REF+} Input Current	$V_{REF+} = 6\text{V}$, $V_{DD} = 6\text{V}$	-	40	50	mA
SUPPLY VOLTAGE					
Static I_{DD} or I_{EE}	LE = Low, D0 - D7 = High	-	100	220	μA
	LE = Low, D0 - D7 = Low	-	-	100	μA
Dynamic I_{DD} or I_{EE}	$V_{OUT} = 10\text{MHz}$, 0V to 5V Square Wave	-	20	-	mA
Dynamic I_{DD} or I_{EE}	$V_{OUT} = 10\text{MHz}$, $\pm 2.5\text{V}$ Square Wave	-	25	-	mA
V_{DD} Rejection	50kHz Sine Wave Applied	-	3	-	mV/V
V_{EE} Rejection	50kHz Sine Wave Applied	-	1	-	mV/V
DIGITAL INPUTS D0 - D7, LE, COMP					
High Level Input Voltage	Note 2	2	-	-	V
Low Level Input Voltage	Note 2	-	-	0.8	V
Leakage Current		-	± 1	± 5	μA
Capacitance		-	5	-	pF
TEMPERATURE COEFFICIENTS					
Output Impedance		-	200	-	ppm/ $^\circ\text{C}$

NOTE:

- Parameter not tested. but guaranteed by design or characterization.

Pin Descriptions

PIN	NAME	DESCRIPTION
1	D7	Most Significant Bit
2	D6	Input
3	D5	Data
4	D4	Bits
5	D3	(High = True)
6	D2	
7	D1	
8	V _{SS}	Digital Ground
9	D ₀	Least Significant Bit. Input Data Bit
10	V _{EE}	Analog Ground
11	V _{REF-}	Reference Voltage Negative Input
12	V _{OUT}	Analog Output
13	V _{REF+}	Reference Voltage Positive Input
14	COMP	Data Complement Control input. Active High
15	LE	Latch Enable Input. Active Low
16	V _{DD}	Digital Power Supply, +5V

Digital Signal Path

The digital inputs (LE, COMP, and D0 - D7) are of TTL compatible HCT High Speed CMOS design: the loading is essentially capacitive and the logic threshold is typically 1.5V.

The 8 data bits, D0 (weighted 2⁰) through D7 (weighted 2⁷), are applied to Exclusive OR gates (see Functional Diagram). The COMP (data complement) control provides the second input to the gates: if COMP is high, the data bits will be inverted as they pass through.

The input data and the LE (latch enable) signals are next applied to a level shifter. The inputs, operating between the levels of V_{DD} and V_{SS}, are shifted to operate between V_{DD} and V_{EE}. V_{EE} optionally at ground or at a negative voltage, will be discussed under bipolar operation. All further logic elements except the output drivers operate from the V_{DD} and V_{EE} supplies.

The upper 3 bits of data, D5 through D7, are input to a 3-to-7 line bar graph encoder. The encoder outputs and D0 through D4 are applied to a feedthrough latch, which is controlled by LE (latch enable).

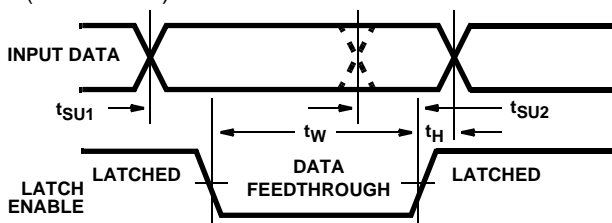

FIGURE 1. DATA TO LATCH ENABLE TIMING

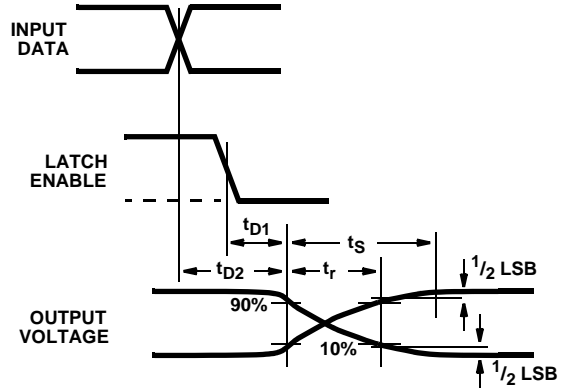

FIGURE 2. DATA AND LATCH ENABLE TO OUTPUT TIMING

Latch Operation

Data is fed from input to output while LE is low: LE should be tied low for non-clocked operation.

Non-clocked operation or changing data while LE is low is not recommended for applications requiring low output “glitch” energy: there is no guarantee of the simultaneous changing of input data or the equal propagation delay of all bits through the converter. Several parameters are given if the converter is to be used in either of these modes: t_{D2} gives the delay from the input changing to the output changing (10%), while t_{SU2} and t_H give the set up and hold times (referred to LE rising edge) needed to latch data. See Figures 1 and 2.

Clocked operation is needed for low “glitch” energy use. Data must meet the given t_{SU1} set up time to the LE falling edge, and the t_H hold time from the LE rising edge. The delay to the output changing, t_{D1}, is now referred to the LE falling edge.

There is no need for a square wave LE clock; LE must only meet the minimum t_W pulse width for successful latch operation. Generally, output timing (desired accuracy of settling) sets the upper limit of usable clock frequency.

Output Structure

The latches feed data to a row of high current CMOS drivers, which in turn feed a modified R2R ladder network.

The “N” channel (pull down) transistor of each driver plus the bottom “2R” resistor are returned to V_{REF-} this is the (-) full-scale reference. The “P” channel (pull up) transistor of each driver is returned to V_{REF+}, the (+) full-scale reference.

In unipolar operation, V_{REF-} would typically be returned to analog ground, but may be raised above ground (see specifications). There is substantial code dependent current that flows from V_{REF+} to V_{REF-} (see V_{REF+} input current in specifications), so V_{REF-} should have a low impedance path to ground.

In bipolar operation, V_{REF-} would be returned to a negative voltage (the maximum voltage rating to V_{DD} must be observed). V_{EE} , which supplies the gate potential for the output drivers, must be returned to a point at least as negative as V_{REF-} . Note that the maximum clocking speed decreases when the bipolar mode is used.

Static Characteristics

The ideal 8-bit D/A would have an output equal to V_{REF-} with an input code of 00_{HEX} (zero scale output), and an output equal to 255/256 of V_{REF+} (referred to V_{REF-}) with an input code of FF_{HEX} (full scale output). The difference between the ideal and actual values of these two parameters are the OFFSET and GAIN errors, respectively; see Figure 3.

If the code into an 8-bit D/A is changed by 1 count, the output should change by 1/255 (full scale output - zero scale output). A deviation from this step size is a differential linearity error, see Figure 4. Note that the error is expressed in fractions of the ideal step size (usually called an LSB). Also note that if the (-) differential linearity error is less (in absolute numbers) than 1 LSB, the device is monotonic. (The output will always increase for increasing code or decrease for decreasing code).

If the code into an 8-bit D/A is at any value, say "N", the output voltage should be N/255 of the full scale output (referred to the zero scale output). Any deviation from that output is an integral linearity error, usually expressed in LSBs. See Figure 4.

Note that OFFSET and GAIN errors do not affect integral linearity, as the linearity is referenced to actual zero and full scale outputs, not ideal. Absolute accuracy would have to also take these errors into account.

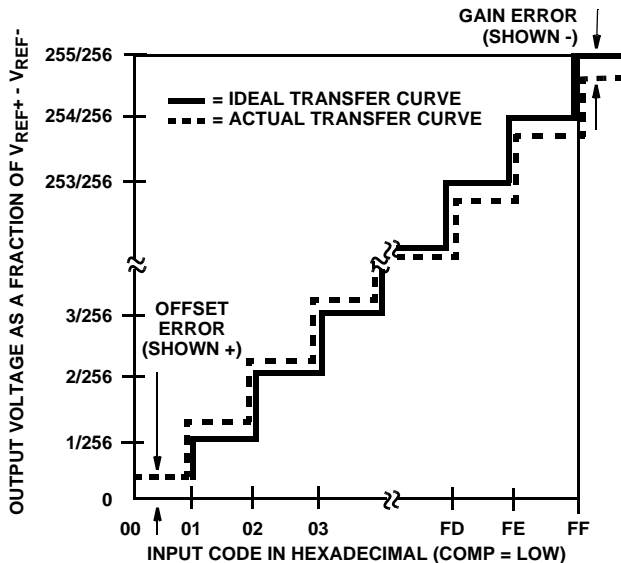

FIGURE 3. D/A OFFSET AND GAIN ERROR

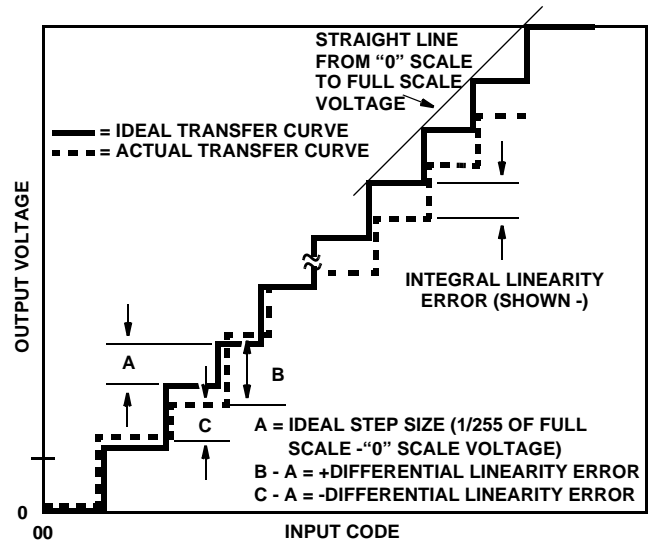

FIGURE 4. D/A INTEGRAL AND DIFFERENTIAL LINEARITY ERROR

Dynamic Characteristics

Keeping the full-scale range ($V_{REF+} - V_{REF-}$) as high as possible gives the best linearity and lowest "glitch" energy (referred to 1V). This provides the best "P" and "N" channel gate drives (hence saturation resistance) and propagation delays. The V_{REF+} (and V_{REF-} if bipolar) terminal should be well bypassed as near the chip as possible.

"Glitch" energy is defined as a spurious voltage that occurs as the output is changed from one voltage to another. In a binary input converter, it is usually highest at the most significant bit transition (7F_{HEX} to 80_{HEX} for an 8 bit device), and can be measured by displaying the output as the input code alternates around that point. The "glitch" energy is the area between the actual output display and an ideal one LSB step voltage (subtracting negative area from positive), at either the positive or negative-going step. It is usually expressed in pV/s.

The CA3338 uses a modified R2R ladder, where the 3 most significant bits drive a bar graph decoder and 7 equally weighted resistors. This makes the "glitch" energy at each 1/8 scale transition (1F_{HEX} to 20_{HEX}, 3F_{HEX} to 40_{HEX}, etc.) essentially equal, and far less than the MSB transition would otherwise display.

For the purpose of comparison to other converters, the output should be resistively divided to 1V full scale. Figure 5 shows a typical hook-up for checking "glitch" energy or settling time.

The settling time of the A/D is mainly a function of the output resistance (approximately 160Ω in parallel with the load resistance) and the load plus internal chip capacitance. Both "glitch" energy and settling time measurements require very good circuit and probe grounding: a probe tip connector such as Tektronix part number 131-0258-00 is recommended.

CA3338, CA3338A

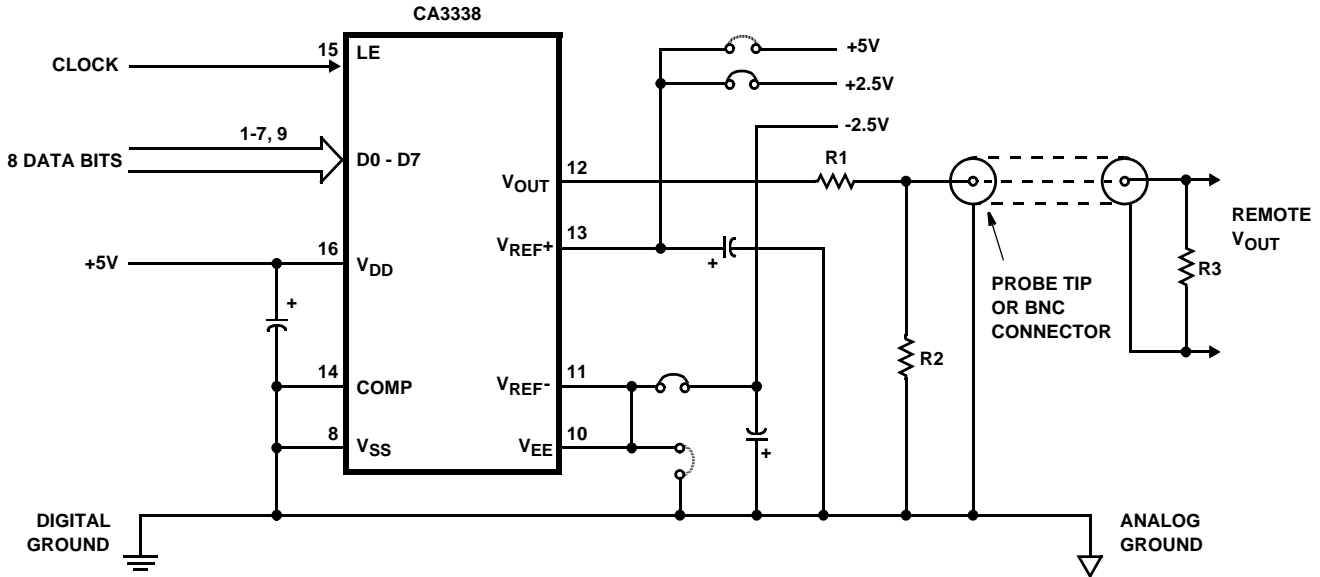

FUNCTION	CONNECTOR	R1	R2	R3	V _{OUT} (P-P)
Oscilloscope Display	Probe Tip	82Ω	62Ω	N/C	1V
Match 93Ω Cable	BNC	75	160	93	1V
Match 75Ω Cable	BNC	18	130	75	1V
Match 50Ω Cable	BNC	Short	75	50	0.79V

NOTES:

- V_{OUT}(P-P) is approximate, and will vary as R_{OUT} of D/A varies.
- All drawn capacitors are 0.1μF multilayer ceramic/4.7μF tantalum.
- Dashed connections are for unipolar operation. Solid connection are for bipolar operation.

FIGURE 5. CA3338 DYNAMIC TEST CIRCUIT

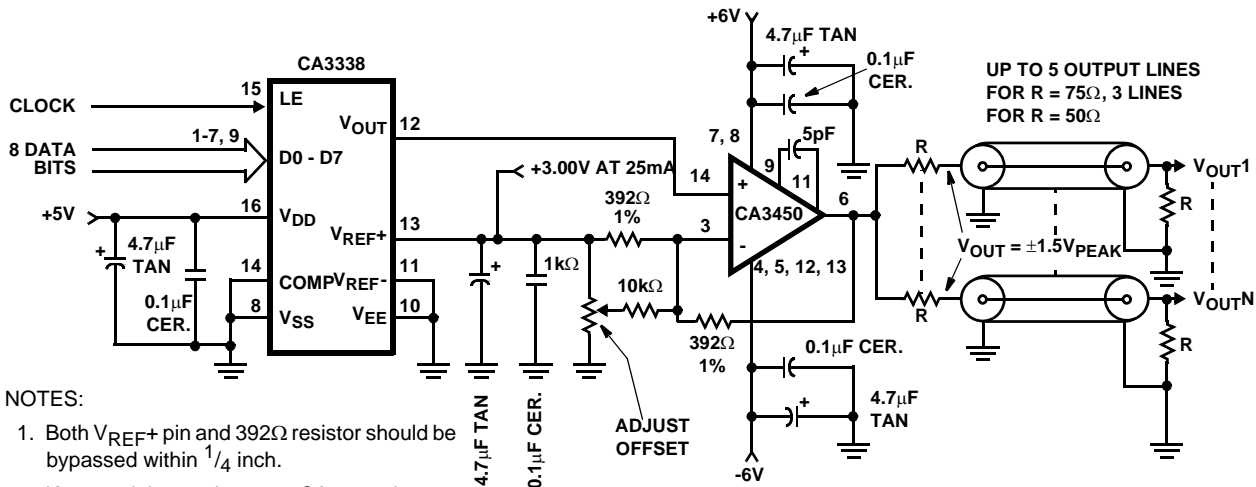

NOTES:

- Both V_{REF+} pin and 392Ω resistor should be bypassed within 1/4 inch.
- Keep nodal capacitance at CA3450 pin 3 as low as possible.
- V_{OUT} Range = ±3V at CA3450.

FIGURE 6. CA3338 AND CA3450 FOR DRIVING MULTIPLE COAXIAL LINES

TABLE 1. OUTPUT VOLTAGE vs INPUT CODE AND V_{REF}

V_{REF+} V_{REF-} STEP SIZE	5.12V 0 0.0200V	5.00V 0 0.0195V	4.608V 0 0.0180V	2.56V -2.56V 0.0200V	2.50V -2.50V 0.0195V
Input Code 11111111 ₂ =FF _{HEX} 11111110 ₂ =FE _{HEX}	5.1000V 5.0800	4.9805V 4.9610	4.5900V 4.5720	2.5400V 2.5200	2.4805V 2.4610
⋮					
10000001 ₂ =81 _{HEX} 10000000 ₂ =80 _{HEX} 01111111 ₂ =7F _{HEX}	2.5800 2.5600 2.5400	2.5195 2.5000 2.4805	2.3220 2.3040 2.2860	0.0200 0.0000 -0.0200	0.0195 0.0000 -0.0195
⋮					
00000001 ₂ =01 _{HEX} 00000000 ₂ =00 _{HEX}	0.0200 0.0000	0.0195 0.0000	0.0180 0.0000	-2.5400 -2.5600	-2.4805 -2.5000

Applications

The output of the CA3338 can be resistively divided to match a doubly terminated 50Ω or 75Ω line, although peak-to-peak swings of less than 1V may result. The output magnitude will also vary with the converter's output impedance. Figure 5 shows such an application. Note that because of the HCT input structure, the CA3338 could be operated up to +7.5V V_{DD} and V_{REF+} supplies and still accept 0V to 5V CMOS input voltages.

If larger voltage swings or better accuracy is desired, a high speed output buffer, such as the HA-5033, HA-2542, or CA3450, can be employed. Figure 6 shows a typical application, with the output capable of driving ±2V into multiple 50Ω terminated lines.

Operating and Handling Considerations

HANDLING

All inputs and outputs of CMOS devices have a network for electrostatic protection during handling. Recommended handling practices for CMOS devices are described in AN6525. "Guide to Better Handling and Operation of CMOS Integrated Circuits."

OPERATING

OPERATING VOLTAGE

During operation near the maximum supply voltage limit, care should be taken to avoid or suppress power supply turn-on and turn-off transients, power supply ripple, or ground noise; any of these conditions must not cause the absolute maximum ratings to be exceeded.

INPUT SIGNALS

To prevent damage to the input protection circuit, input signals should never be greater than V_{DD} nor less than V_{SS} . Input currents must not exceed 20mA even when the power supply is off.

UNUSED INPUTS

A connection must be provided at every input terminal. All unused input terminals must be connected to either V_{CC} or GND, whichever is appropriate.

Dual-In-Line Plastic Packages (PDIP)

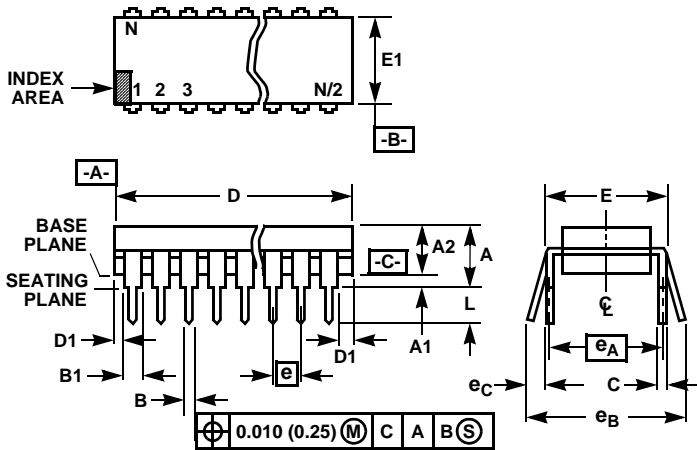

NOTES:

- Controlling Dimensions: INCH. In case of conflict between English and Metric dimensions, the inch dimensions control.
- Dimensioning and tolerancing per ANSI Y14.5M-1982.
- Symbols are defined in the "MO Series Symbol List" in Section 2.2 of Publication No. 95.
- Dimensions A, A1 and L are measured with the package seated in JEDEC seating plane gauge GS-3.
- D, D1, and E1 dimensions do not include mold flash or protrusions. Mold flash or protrusions shall not exceed 0.010 inch (0.25mm).
- E and e_A are measured with the leads constrained to be perpendicular to datum [-C-].
- e_B and e_C are measured at the lead tips with the leads unconstrained. e_C must be zero or greater.
- B1 maximum dimensions do not include dambar protrusions. Dambar protrusions shall not exceed 0.010 inch (0.25mm).
- N is the maximum number of terminal positions.
- Corner leads (1, N, N/2 and N/2 + 1) for E8.3, E16.3, E18.3, E28.3, E42.6 will have a B1 dimension of 0.030 - 0.045 inch (0.76 - 1.14mm).

E16.3 (JEDEC MS-001-BB ISSUE D)
16 LEAD DUAL-IN-LINE PLASTIC PACKAGE

SYMBOL	INCHES		MILLIMETERS		NOTES
	MIN	MAX	MIN	MAX	
A	-	0.210	-	5.33	4
A1	0.015	-	0.39	-	4
A2	0.115	0.195	2.93	4.95	-
B	0.014	0.022	0.356	0.558	-
B1	0.045	0.070	1.15	1.77	8, 10
C	0.008	0.014	0.204	0.355	-
D	0.735	0.775	18.66	19.68	5
D1	0.005	-	0.13	-	5
E	0.300	0.325	7.62	8.25	6
E1	0.240	0.280	6.10	7.11	5
e	0.100 BSC		2.54 BSC		-
e _A	0.300 BSC		7.62 BSC		6
e _B	-	0.430	-	10.92	7
L	0.115	0.150	2.93	3.81	4
N	16		16		9

Rev. 0 12/93

Small Outline Plastic Packages (SOIC)

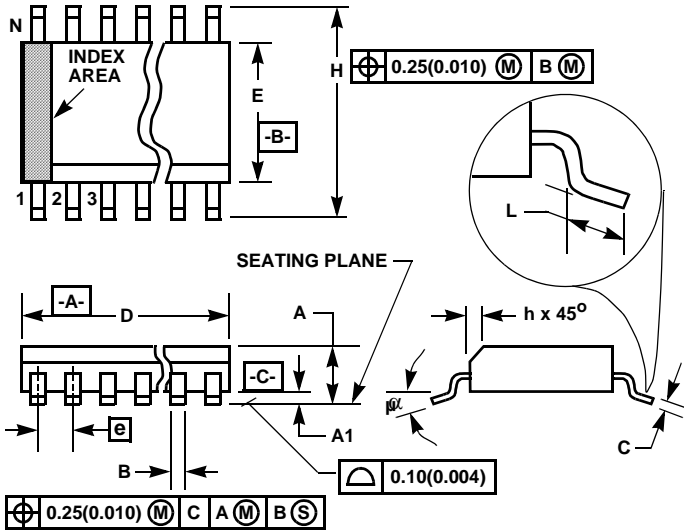

M16.3 (JEDEC MS-013-AA ISSUE C)
16 LEAD WIDE BODY SMALL OUTLINE PLASTIC PACKAGE

SYMBOL	INCHES		MILLIMETERS		NOTES
	MIN	MAX	MIN	MAX	
A	0.0926	0.1043	2.35	2.65	-
A1	0.0040	0.0118	0.10	0.30	-
B	0.013	0.0200	0.33	0.51	9
C	0.0091	0.0125	0.23	0.32	-
D	0.3977	0.4133	10.10	10.50	3
E	0.2914	0.2992	7.40	7.60	4
e	0.050 BSC		1.27 BSC		-
H	0.394	0.419	10.00	10.65	-
h	0.010	0.029	0.25	0.75	5
L	0.016	0.050	0.40	1.27	6
N	16		16		7
α	0°	8°	0°	8°	-

NOTES:

1. Symbols are defined in the "MO Series Symbol List" in Section 2.2 of Publication Number 95.
2. Dimensioning and tolerancing per ANSI Y14.5M-1982.
3. Dimension "D" does not include mold flash, protrusions or gate burrs. Mold flash, protrusion and gate burrs shall not exceed 0.15mm (0.006 inch) per side.
4. Dimension "E" does not include interlead flash or protrusions. Interlead flash and protrusions shall not exceed 0.25mm (0.010 inch) per side.
5. The chamfer on the body is optional. If it is not present, a visual index feature must be located within the crosshatched area.
6. "L" is the length of terminal for soldering to a substrate.
7. "N" is the number of terminal positions.
8. Terminal numbers are shown for reference only.
9. The lead width "B", as measured 0.36mm (0.014 inch) or greater above the seating plane, shall not exceed a maximum value of 0.61mm (0.024 inch)
10. Controlling dimension: MILLIMETER. Converted inch dimensions are not necessarily exact.

Rev. 0 12/93

All Intersil U.S. products are manufactured, assembled and tested utilizing ISO9000 quality systems.
Intersil Corporation's quality certifications can be viewed at www.intersil.com/design/quality

Intersil products are sold by description only. Intersil Corporation reserves the right to make changes in circuit design, software and/or specifications at any time without notice. Accordingly, the reader is cautioned to verify that data sheets are current before placing orders. Information furnished by Intersil is believed to be accurate and reliable. However, no responsibility is assumed by Intersil or its subsidiaries for its use; nor for any infringements of patents or other rights of third parties which may result from its use. No license is granted by implication or otherwise under any patent or patent rights of Intersil or its subsidiaries.

For information regarding Intersil Corporation and its products, see www.intersil.com



LittleDiode supplies new, hard to find or obsolete electronic components and semiconductors all over the world.

With over two million different components listed you are sure to find the part you need.

Feel free to visit us today at our online store:

LittleDiode.com

Looking forward to providing you with the best possible service.