

HD14042B

Quadruple Latch

The HD14042B quad latch has a separate data input, but all four latches share a common clock. The clock polarity (high or low) used to strobe data through the latches can be reversed using the polarity input. Information present at the data input is transferred to outputs Q and \bar{Q} during the clock level which is determined by the polarity input. When the polarity input is in the logic "0" state, data is transferred during the low clock level, and when the polarity input is in the logic "1" state the transfer occurs during the high clock level.

FEATURES

- Buffered Data Inputs
- Common Clock
- Positive or Negative Edge Clocked
- Q and \bar{Q} Outputs
- Quiescent Current = 2nA/pkg typ. @5V
- Supply Voltage Range = 3 to 18V
- Capable of Driving One Low-power Schottky TTL Load Over the Rated Temperature Range

PIN ARRANGEMENT

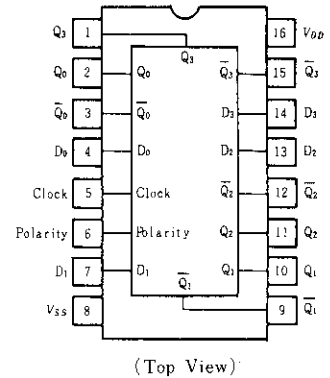

LOGIC DIAGRAM

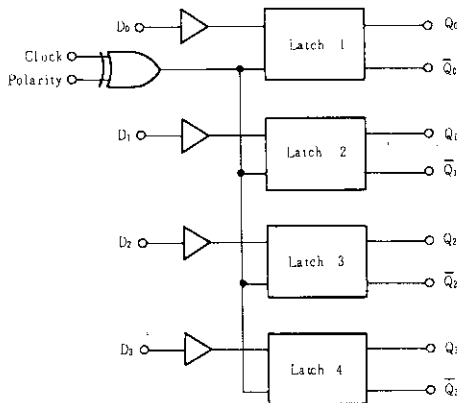

TRUTH TABLE

Clock	Polarity	Q
0	0	Data
1	0	Latch
0	1	Data
1	1	Latch

DC CHARACTERISTIC TEST CIRCUIT

(Data to Q, \bar{Q})

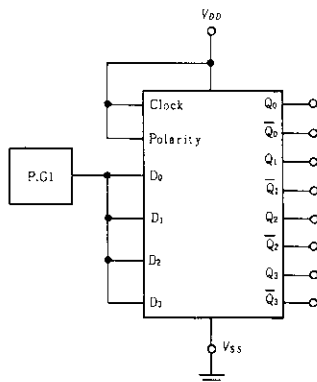

For Power Dissipation test, each output is loaded with capacitance C_L .

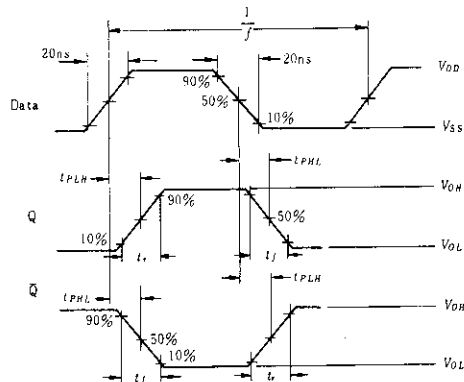

■ ELECTRICAL CHARACTERISTICS

Characteristic		Symbol	Test Conditions	-40°C		25°C			85°C		Unit		
				min	max	min	typ	max	min	max			
Output Voltage		V _{OL}	V _{in} = V _{DD} or 0	5.0	-	0.05	-	0	0.05	-	0.05	V	
				10	-	0.05	-	0	0.05	-	0.05		
				15	-	0.05	-	0	0.05	-	0.05		
		V _{OH}	V _{in} = 0 or V _{DD}	5.0	4.95	-	4.95	5.0	-	4.95	-	V	
				10	9.95	-	9.95	10	-	9.95	-		
				15	14.95	-	14.95	15	-	14.95	-		
Input Voltage		Data	V _{IL}	5.0	V _{out} = 4.5 or 0.5V	-	1.5	-	2.25	1.5	-	1.5	V
				10	V _{out} = 9.0 or 1.0V	-	3.0	-	4.50	3.0	-	3.0	
				15	V _{out} = 13.5 or 1.5V	-	4.0	-	6.75	4.0	-	4.0	
		Clock Polarity	V _{IL}	5.0	V _{out} = 4.5 or 0.5V	-	1.5	-	2.25	1.5	-	1.5	
				10	V _{out} = 9.0 or 1.0V	-	3.0	-	4.50	3.0	-	3.0	
				15	V _{out} = 13.5 or 1.5V	-	3.75	-	6.75	3.75	-	3.75	
Data	V _{IH}	5.0	V _{out} = 0.5 or 4.5V	3.5	-	3.5	2.75	-	3.5	-	V		
		10	V _{out} = 1.0 or 9.0V	7.0	-	7.0	5.50	-	7.0	-			
		15	V _{out} = 1.5 or 13.5V	11.0	-	11.0	8.25	-	11.0	-			
		Clock Polarity	V _{IH}	5.0	V _{out} = 0.5 or 4.5V	3.5	-	3.5	2.75	-		3.5	-
				10	V _{out} = 1.0 or 9.0V	7.0	-	7.0	5.50	-		7.0	-
				15	V _{out} = 1.5 or 13.5V	11.25	-	11.25	8.25	-		11.25	-
Output Drive Current		I _{OH}	V _{OH}	5.0	2.5V	-1.0	-	-0.8	-1.7	-	-0.6	-	mA
				5.0	4.6V	-0.2	-	-0.16	-0.36	-	-0.12	-	
				10	9.5V	-0.5	-	-0.4	-0.9	-	-0.3	-	
		15	13.5V	-1.4	-	-1.2	-3.5	-	-1.0	-			
		I _{OL}	V _{OL}	5.0	0.4V	0.52	-	0.44	0.88	-	0.36	-	
				10	0.5V	1.3	-	1.1	2.25	-	0.9	-	
15	1.5V			3.6	-	3.0	8.8	-	2.4	-			
Input Current	I _{in}	15		-	±0.3	-	±0.00001	±0.3	-	±1.0	μA		
Input Capacitance	C _{in}	-	V _{in} = 0	-	-	-	5.0	7.5	-	-	pF		
Quiescent Current		I _{DD}	Zero Signal, per Package	5.0		-	4.0	-	0.002	4.0	-	30	μA
				10		-	8.0	-	0.004	8.0	-	60	
				15		-	16	-	0.006	16	-	120	
Total Supply Current*		I _T	Dynamic + I _{DDi} , per Gate	5.0		-	-	-	1.0	-	-	μA	
				10		-	-	-	2.0	-	-		
				15	C _L = 50pF, f = 1kHz	-	-	-	3.0	-	-		-

* To calculate total supply current at frequency other than 1kHz.
 @ V_{DD} = 5.0V I_T = (1.0 μA/kHz) f + I_{DD}, @ V_{DD} = 10V I_T = (2.0 μA/kHz) f + I_{DD}, @ V_{DD} = 15V I_T = (3.0 μA/kHz) f + I_{DD}

■SWITCHING CHARACTERISTICS ($C_L=50\text{pF}$, $T_a=25^\circ\text{C}$)

Characteristic		Symbol	V_{DD} (V)	min	typ	max	Unit
Output Rise Time		t_r	5.0	—	180	360	ns
			10	—	90	180	
			15	—	65	130	
Output Fall Time		t_f	5.0	—	100	200	ns
			10	—	50	100	
			15	—	40	80	
Propagation Delay Time	Data to Q, \bar{Q}	t_{PLH}	5.0	—	220	440	ns
			10	—	90	180	
			15	—	60	120	
	Clock to Q, \bar{Q}	t_{PHL}	5.0	—	220	440	
			10	—	90	180	
			15	—	60	120	
Clock Pulse Width		PW_C	5.0	300	150	—	ns
			10	100	50	—	
			15	80	40	—	
Clock Rise Time		t_r	5.0	No Limit			
			10				
			15				
Hold Time		t_{hold}	5.0	100	50	—	ns
			10	50	25	—	
			15	40	20	—	
Setup Time		t_{setup}	5.0	50	0	—	ns
			10	30	0	—	
			15	25	0	—	

■AC TEST CIRCUIT (Clock to Q)

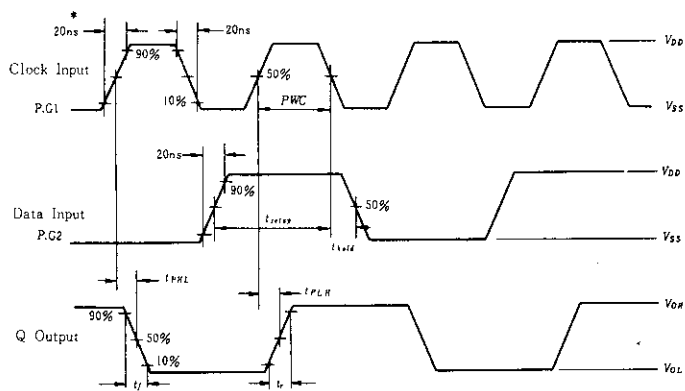
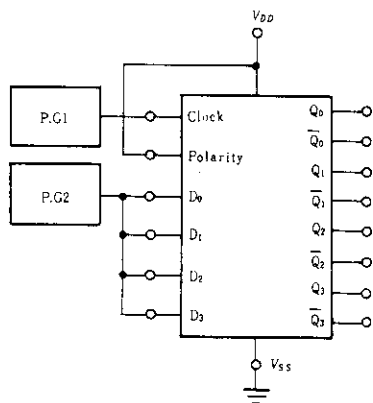

* Input clock rise time is 20ns except for maximum



Hitachi Code	DP-16
JEDEC	Conforms
EIAJ	Conforms
Weight (reference value)	1.07 g

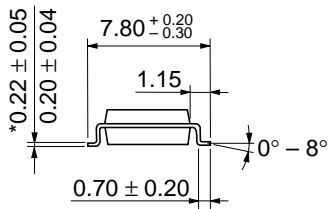

*Dimension including the plating thickness
Base material dimension

Hitachi Code	FP-16DA
JEDEC	—
EIAJ	Conforms
Weight (reference value)	0.24 g



*Dimension including the plating thickness
Base material dimension

Hitachi Code	FP-16DN
JEDEC	Conforms
EIAJ	Conforms
Weight (reference value)	0.15 g

Cautions

1. Hitachi neither warrants nor grants licenses of any rights of Hitachi's or any third party's patent, copyright, trademark, or other intellectual property rights for information contained in this document. Hitachi bears no responsibility for problems that may arise with third party's rights, including intellectual property rights, in connection with use of the information contained in this document.
2. Products and product specifications may be subject to change without notice. Confirm that you have received the latest product standards or specifications before final design, purchase or use.
3. Hitachi makes every attempt to ensure that its products are of high quality and reliability. However, contact Hitachi's sales office before using the product in an application that demands especially high quality and reliability or where its failure or malfunction may directly threaten human life or cause risk of bodily injury, such as aerospace, aeronautics, nuclear power, combustion control, transportation, traffic, safety equipment or medical equipment for life support.
4. Design your application so that the product is used within the ranges guaranteed by Hitachi particularly for maximum rating, operating supply voltage range, heat radiation characteristics, installation conditions and other characteristics. Hitachi bears no responsibility for failure or damage when used beyond the guaranteed ranges. Even within the guaranteed ranges, consider normally foreseeable failure rates or failure modes in semiconductor devices and employ systemic measures such as fail-safes, so that the equipment incorporating Hitachi product does not cause bodily injury, fire or other consequential damage due to operation of the Hitachi product.
5. This product is not designed to be radiation resistant.
6. No one is permitted to reproduce or duplicate, in any form, the whole or part of this document without written approval from Hitachi.
7. Contact Hitachi's sales office for any questions regarding this document or Hitachi semiconductor products.

HITACHI

Hitachi, Ltd.

Semiconductor & Integrated Circuits.
Nippon Bldg., 2-6-2, Ohte-machi, Chiyoda-ku, Tokyo 100-0004, Japan
Tel: Tokyo (03) 3270-2111 Fax: (03) 3270-5109

URL North America : <http://semiconductor.hitachi.com/>
 Europe : <http://www.hitachi-eu.com/hel/ecg>
 Asia (Singapore) : <http://www.has.hitachi.com.sg/grp3/sicd/index.htm>
 Asia (Taiwan) : http://www.hitachi.com.tw/E/Product/SICD_Frame.htm
 Asia (HongKong) : <http://www.hitachi.com.hk/eng/bo/grp3/index.htm>
 Japan : <http://www.hitachi.co.jp/Sicd/indx.htm>

For further information write to:

Hitachi Semiconductor
(America) Inc.
179 East Tasman Drive,
San Jose, CA 95134
Tel: <1> (408) 433-1990
Fax: <1> (408) 433-0223

Hitachi Europe GmbH
Electronic components Group
Dornacher Straße 3
D-85622 Feldkirchen, Munich
Germany
Tel: <49> (89) 9 9180-0
Fax: <49> (89) 9 29 30 00

Hitachi Europe Ltd.
Electronic Components Group.
Whitebrook Park
Lower Cookham Road
Maidenhead
Berkshire SL6 8YA, United Kingdom
Tel: <44> (1628) 585000
Fax: <44> (1628) 778322

Hitachi Asia Pte. Ltd.
16 Collyer Quay #20-00
Hitachi Tower
Singapore 049318
Tel: 535-2100
Fax: 535-1533

Hitachi Asia Ltd.
Taipei Branch Office
3F, Hung Kuo Building, No.167,
Tun-Hwa North Road, Taipei (105)
Tel: <886> (2) 2718-3666
Fax: <886> (2) 2718-8180

Hitachi Asia (Hong Kong) Ltd.
Group III (Electronic Components)
7/F., North Tower, World Finance Centre,
Harbour City, Canton Road, Tsim Sha Tsui,
Kowloon, Hong Kong
Tel: <852> (2) 735 9218
Fax: <852> (2) 730 0281
Telex: 40815 HITEC HX

Copyright ' Hitachi, Ltd., 1999. All rights reserved. Printed in Japan.

HITACHI



LittleDiode supplies new, hard to find or obsolete electronic components and semiconductors all over the world.

With over two million different components listed you are sure to find the part you need.

Feel free to visit us today at our online store:

LittleDiode.com

Looking forward to providing you with the best possible service.