

93L14 Quad Latch

General Description

The 93L14 is a multifunctional 4-bit latch designed for general purpose storage applications in high speed digital systems. All outputs have active pull-up circuitry to provide high capacitance drive and to provide low impedance in both logic states for good noise immunity.

Features

- Can be used as single input D latches or set/reset latches
- Active low enable gate input
- Overriding master reset

Connection Diagram

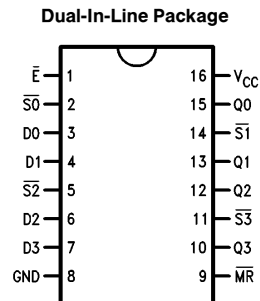

TL/F/9612-1

Order Number 93L14DMQB or 93L14FMQB
See NS Package Number J16A or W16A

Logic Symbol

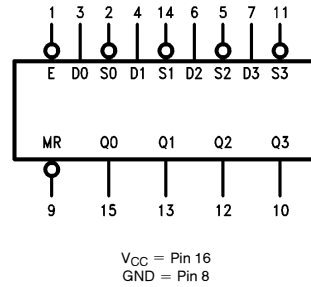

TL/F/9612-2

V_{CC} = Pin 16
 GND = Pin 8

Pin Names	Description
\bar{E}	Enable Input (Active LOW)
D0–D3	Data Inputs
$\bar{S}0$ – $\bar{S}3$	Set Inputs (Active LOW)
\bar{MR}	Master Reset Input (Active LOW)
Q0–Q3	Latch Outputs

Absolute Maximum Ratings (Note)

If Military/Aerospace specified devices are required, please contact the National Semiconductor Sales Office/Distributors for availability and specifications.

Supply Voltage	7V
Input Voltage	5.5V
Operating Free Air Temperature Range	
MIL	–55°C to +125°C
Storage Temperature Range	–65°C to +150°C

Note: The “Absolute Maximum Ratings” are those values beyond which the safety of the device cannot be guaranteed. The device should not be operated at these limits. The parametric values defined in the “Electrical Characteristics” table are not guaranteed at the absolute maximum ratings. The “Recommended Operating Conditions” table will define the conditions for actual device operation.

Recommended Operating Conditions

Symbol	Parameter	93L14 (MIL)			Units
		Min	Nom	Max	
V _{CC}	Supply Voltage	4.5	5	5.5	V
V _{IH}	High Level Input Voltage	2			V
V _{IL}	Low Level Input Voltage			0.7	V
I _{OH}	High Level Output Voltage			–400	μA
I _{OL}	Low Level Output Current			4.8	mA
T _A	Free Air Operating Temperature	–55		125	°C
t _s (H)	Setup Time HIGH or LOW	10			ns
t _s (L)	D _n to \bar{E}	20			ns
t _h (H)	Hold Time HIGH or LOW	0			ns
t _h (L)	D _n to \bar{E}	10			ns
t _s (H)	Setup Time HIGH, D _n to \bar{S}_n	15			ns
t _h (L)	Hold Time LOW, D _n to \bar{S}_n	5			ns
t _w (L)	\bar{E} Pulse Width LOW	30			ns
t _w (L)	\overline{MR} Pulse Width LOW	25			ns
t _{rec}	Recovery Time, \overline{MR} to \bar{E}	5			ns

Electrical Characteristics

Over recommended operating free air temperature range (unless otherwise noted)

Symbol	Parameter	Conditions	Min	Typ (Note 1)	Max	Units
V_I	Input Clamp Voltage	$V_{CC} = \text{Min}, I_I = -10 \text{ mA}$			-1.5	V
V_{OH}	High Level Output Voltage	$V_{CC} = \text{Min}, I_{OH} = \text{Max}, V_{IL} = \text{Max}, V_{IH} = \text{Min}$	2.4			V
V_{OL}	Low Level Output Voltage	$V_{CC} = \text{Min}, I_{OL} = \text{Max}, V_{IH} = \text{Min}, V_{IL} = \text{Max}$			0.3	V
I_I	Input Current @ Max Input Voltage	$V_{CC} = \text{Max}, V_I = 5.5V$			1	mA
I_{IH}	High Level Input Current	$V_{CC} = \text{Max}, V_I = 2.4V$	Inputs		20	μA
			D_n		30	
I_{IL}	Low Level Input Current	$V_{CC} = \text{Max}, V_I = 0.3V$	Inputs		-400	μA
			D_n		-600	
I_{OS}	Short Circuit Output Current	$V_{CC} = \text{Max}$ (Note 2)	-2.5		-25	mA
I_{CC}	Supply Current	$V_{CC} = \text{Max}$ (Note 3)			16.5	mA

Note 1: All typicals are at $V_{CC} = 5V, T_A = 25^\circ\text{C}$.

Note 2: Not more than one output should be shorted at a time, and the duration should not exceed one second.

Note 3: I_{CC} is measured with all outputs open and all inputs grounded.

Switching Characteristics

$V_{CC} = +5.0V, T_A = +25^\circ\text{C}$ (See Section 1 for waveforms and load configurations)

Symbol	Parameter	$C_L = 15 \text{ pF}$		Units
		Min	Max	
t_{PLH} t_{PHL}	Propagation Delay \bar{E} to Q_n		45 36	ns
t_{PLH} t_{PHL}	Propagation Delay D_n to Q_n		30 30	ns
t_{PLH}	Propagation Delay, \overline{MR} to Q_n		30	ns
t_{PHL}	Propagation Delay, \overline{S}_n to Q_n		33	ns

Functional Description

The 93L14 consists of four latches with a common active LOW Enable input and active LOW Master Reset input. When the Enable goes HIGH, data present in the latches is stored and the state of the latch is no longer affected by the \bar{S}_n and D_n inputs. The Master Reset when activated overrides all other input conditions forcing all latch outputs LOW. Each of the four latches can be operated in one of two modes:

D-TYPE-LATCH—For D-type operation the \bar{S} input of a latch is held LOW. While the common Enable is active the latch output follows the D input. Information present at the latch output is stored in the latch when the Enable goes HIGH.

SET/RESET LATCH—During set/reset operation when the common Enable is LOW a latch is reset by a LOW on the D input, and can be set by a LOW on the \bar{S} input if the D input is HIGH. If both \bar{S} and D inputs are LOW, the D input will dominate and the latch will be reset. When the Enable goes HIGH, the latch remains in the last state prior to disablement. The two modes of latch operation are shown in the Truth Table.

Truth Table

\overline{MR}	\overline{E}	D	\overline{S}	Q_n	Operation
H	L	L	L	L	D Mode
H	L	H	L	L	
H	H	X	X	Q_{n-1}	
H	L	L	L	L	R/S Mode
H	L	H	L	H	
H	L	L	H	L	
H	L	H	H	Q_{n-1}	
H	H	X	X	Q_{n-1}	
L	X	X	X	L	RESET

H = HIGH Voltage Level
 L = LOW Voltage Level
 X = Immaterial
 Q_{n-1} = Previous Output State
 Q_n = Present Output State

Logic Diagram

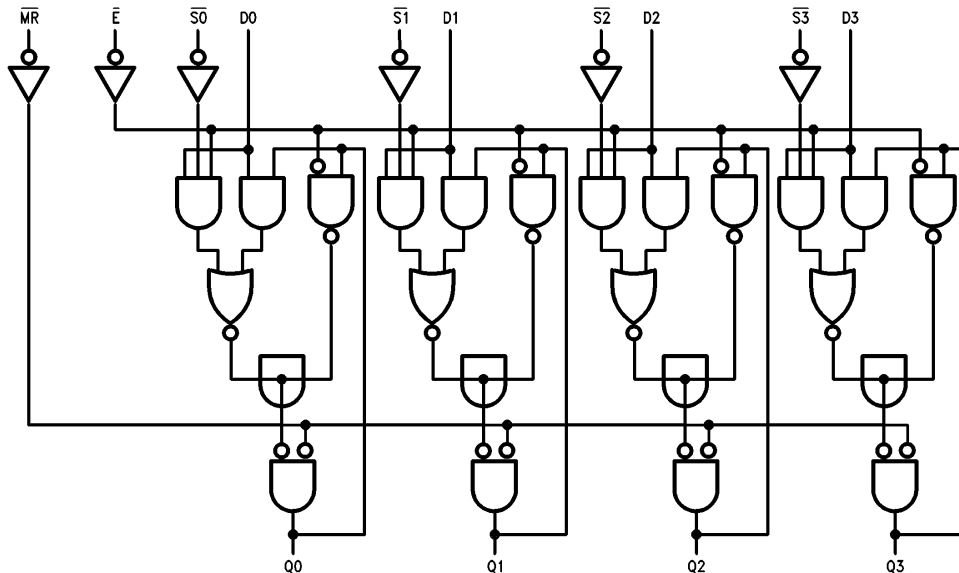

TL/F/9612-3

Physical Dimensions inches (millimeters)

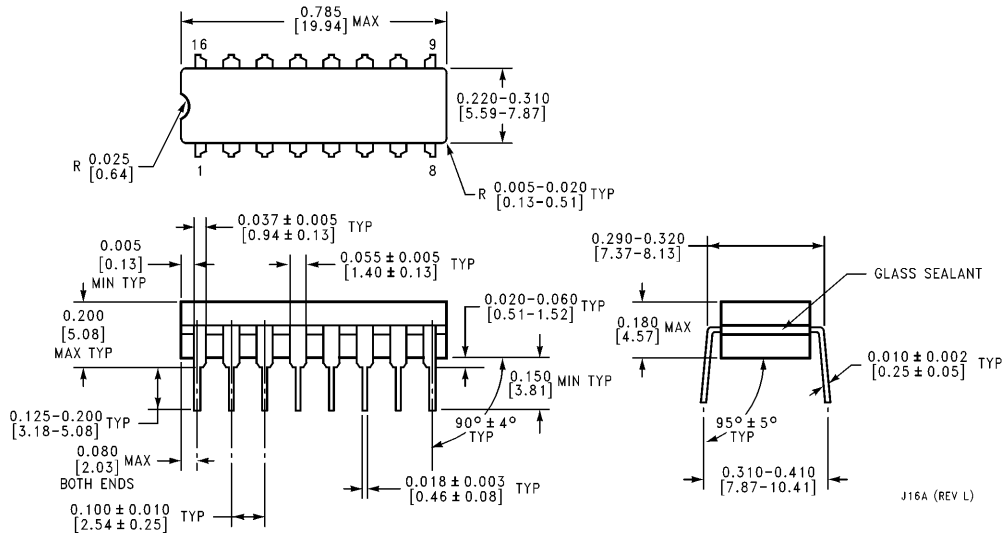

16-Lead Ceramic Dual-In-Line Package (J)
Order Number 93L14DMQB
NS Package Number J16A

J16A (REV L)

Physical Dimensions inches (millimeters) (Continued)

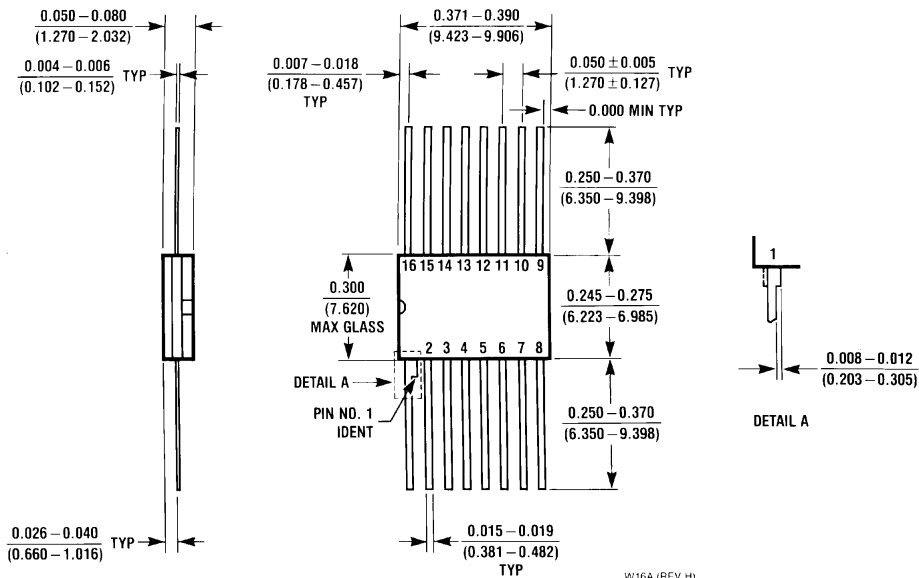

**16-Lead Ceramic Flat Package (W)
Order Number 93L14FMQB
NS Package Number W16A**

LIFE SUPPORT POLICY

NATIONAL'S PRODUCTS ARE NOT AUTHORIZED FOR USE AS CRITICAL COMPONENTS IN LIFE SUPPORT DEVICES OR SYSTEMS WITHOUT THE EXPRESS WRITTEN APPROVAL OF THE PRESIDENT OF NATIONAL SEMICONDUCTOR CORPORATION. As used herein:

1. Life support devices or systems are devices or systems which, (a) are intended for surgical implant into the body, or (b) support or sustain life, and whose failure to perform, when properly used in accordance with instructions for use provided in the labeling, can be reasonably expected to result in a significant injury to the user.
2. A critical component is any component of a life support device or system whose failure to perform can be reasonably expected to cause the failure of the life support device or system, or to affect its safety or effectiveness.



National Semiconductor Corporation
1111 West Bardin Road
Arlington, TX 76017
Tel: 1(800) 272-9959
Fax: 1(800) 737-7018

National Semiconductor Europe
Fax: (+49) 0-180-530 85 86
Email: onjwge@tevm2.nsc.com
Deutsch Tel: (+49) 0-180-530 85 85
English Tel: (+49) 0-180-532 78 32
Français Tel: (+49) 0-180-532 93 58
Italiano Tel: (+49) 0-180-534 16 80

National Semiconductor Hong Kong Ltd.
13th Floor, Straight Block,
Ocean Centre, 5 Canton Rd.
Tsimshatsui, Kowloon
Hong Kong
Tel: (852) 2737-1600
Fax: (852) 2736-9960

National Semiconductor Japan Ltd.
Tel: 81-043-299-2309
Fax: 81-043-299-2408

National does not assume any responsibility for use of any circuitry described, no circuit patent licenses are implied and National reserves the right at any time without notice to change said circuitry and specifications.

This datasheet has been downloaded from:

www.DatasheetCatalog.com

Datasheets for electronic components.

National Semiconductor was acquired by Texas Instruments.

http://www.ti.com/corp/docs/investor_relations/pr_09_23_2011_national_semiconductor.html

This file is the datasheet for the following electronic components:

93L14DMQB - <http://www.ti.com/product/93l14dmb?HQS=TI-null-null-dscatalog-df-pf-null-ww>

93L14FMQB - <http://www.ti.com/product/93l14fmb?HQS=TI-null-null-dscatalog-df-pf-null-ww>



LittleDiode supplies new, hard to find or obsolete electronic components and semiconductors all over the world.

With over two million different components listed you are sure to find the part you need.

Feel free to visit us today at our online store:

LittleDiode.com

Looking forward to providing you with the best possible service.