

## ADM663A/ADM666A\*

### FEATURES

#### Tri-Mode Operation

- 3.3 V, 5 V Fixed or +1.3 V to +16 V Adjustable
- Low Power CMOS: 9  $\mu$ A max Quiescent Current
- High Current 100 mA Output
- Low Dropout Voltage
- Upgrade for ADM663/ADM666
- "Small" 0.1  $\mu$ F Output Capacitor (0805 Style)
- +2 V to +16.5 V Operating Range
- Low Battery Detector ADM666A
- No Overshoot on Power-Up
- Thermal Shutdown

### APPLICATIONS

- Handheld Instruments
- LCD Display Systems
- Pagers
- Battery Operated Equipment

### GENERAL DESCRIPTION

The ADM663A/ADM666A are precision linear voltage regulators featuring a maximum quiescent current of 9  $\mu$ A. They can be used to give a fixed +3.3 V or +5 V output with no additional external components or can be adjusted from 1.3 V to 16 V using two external resistors. Fixed or adjustable operation is automatically selected via the  $V_{SET}$  input. The low quiescent current makes these devices especially suitable for battery powered systems. The input voltage range is 2 V to 16.5 V, and an output current up to 100 mA is provided. Current limiting may be set using a single external resistor. For additional safety, an internal thermal shutdown circuit monitors the internal die temperature.

The ADM666A features additional low battery monitoring circuitry to detect for low battery voltages.

The ADM663A/ADM666A are pin compatible enhancements for the ADM663/ADM666. Improvements include an additional 3.3 V output range, higher output current, and operation with a small output capacitor.

The ADM663A/ADM666A are available in an 8-pin DIP and narrow surface mount (SOIC) packages.

### FUNCTIONAL BLOCK DIAGRAMS

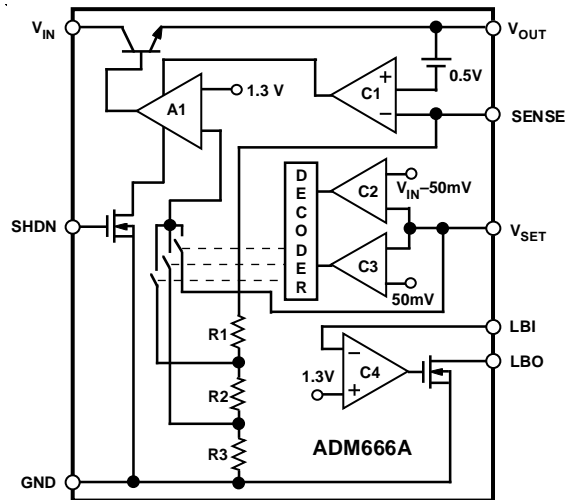
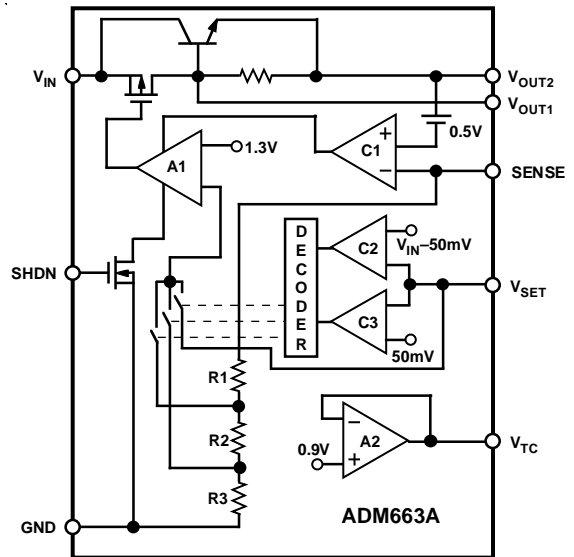

\*Patent pending.

### REV. 0

Information furnished by Analog Devices is believed to be accurate and reliable. However, no responsibility is assumed by Analog Devices for its use, nor for any infringements of patents or other rights of third parties which may result from its use. No license is granted by implication or otherwise under any patent or patent rights of Analog Devices.

# ADM663A/ADM666A—SPECIFICATIONS ( $V_{IN} = +9\text{ V}$ , $T_A = T_{MIN}$ to $T_{MAX}$ , unless otherwise noted)

Parameter	Min	Typ	Max	Units	Test Conditions/Comments
Input Voltage, $V_{IN}$	2.0		16.5	V	
Quiescent Current, $I_Q$		6	9	$\mu\text{A}$	No Load, $V_{IN} = +16.5\text{ V}$
Output Voltage, $V_{OUT(2)}$ (+5 V Mode)	4.75	5.0	5.25	V	$V_{SET} = \text{GND}$
Output Voltage, $V_{OUT(2)}$ (+3.3 V Mode)	3.135	3.3	3.465	V	$V_{SET} = V_{IN}$
Dropout Voltage, $V_{DO}$		0.75	0.9	V	$I_{OUT} = 40\text{ mA}$ , $V_{OUT} = +14.5\text{ V}$
Dropout Voltage, $V_{DO}$		1.0	1.2	V	$I_{OUT} = 100\text{ mA}$ , $V_{OUT} = +14.5\text{ V}$
Line Regulation ( $\Delta V_{OUT(2)}/\Delta V_{IN}$ )		0.03	0.35	%/V	$+2\text{ V} \leq V_{IN} \leq +15\text{ V}$ , $V_{OUT} = V_{REF}$
Load Regulation $\Delta V_{OUT(2)}; (\Delta V_{OUT(2)}/\Delta I_{OUT(2)})$		0.3	1.0	$\Omega$	$V_{IN} = (V_{OUT} + 3\text{ V})$ , $1\text{ mA} \leq I_{OUT(2)} \leq 100\text{ mA}$
		0.15	0.35	$\Omega$	$V_{SET} = \text{GND}$ (Fixed +5 V Output)
		0.15	0.30	$\Omega$	$V_{SET} = V_{IN}$ (Fixed +3.3 V Output)
		0.25	1.2	$\Omega$	$V_{SET} = \text{Resistive Divider}$ (Adjustable Output)
Reference Voltage, $V_{SET}$	1.27		1.33	V	ADM663A, $50\text{ }\mu\text{A} \leq I_{OUT1} \leq 10\text{ mA}$
Reference Tempco ( $\Delta V_{SET}/\Delta T$ )		$\pm 100$		ppm/ $^{\circ}\text{C}$	$T_A = +25^{\circ}\text{C}$ , $V_{OUT} = V_{SET}$
$V_{SET}$ Internal Threshold					
$V_{F/A}$ Low		50		mV	$V_{SET} < V_{F/A}$ Low for +5 V Output
$V_{F/A}$ High		$V_{IN} - 50$		mV	$V_{SET} > V_{F/A}$ High for +3.3 V Output
$V_{SET}$ Input Current, $I_{SET}$		$\pm 0.01$	$\pm 10$	nA	
Shutdown Input Voltage, $V_{SHDN}$	1.4			V	$V_{SHDN}$ High = Output Off
			0.3	V	$V_{SHDN}$ Low = Output On
Shutdown Input Current, $I_{SHDN}$		$\pm 0.01$	$\pm 10$	nA	
SENSE Input Threshold, $V_{OUT} - V_{SENSE}$		0.5		V	Current Limit Threshold
SENSE Input Resistance, $R_{SENSE}$		3		M $\Omega$	
Input-Output Saturation Resistance, $R_{SAT}$ ADM663A, $V_{OUT1}$		200	400	$\Omega$	$V_{IN} = +2\text{ V}$ , $I_{OUT} = 1\text{ mA}$
		20	40	$\Omega$	$V_{IN} = +9\text{ V}$ , $I_{OUT} = 10\text{ mA}$
		20	30	$\Omega$	$V_{IN} = +15\text{ V}$ , $I_{OUT} = 10\text{ mA}$
Output Current, $I_{OUT(2)}$	100			mA	$+3\text{ V} \leq V_{IN} \leq +16.5\text{ V}$ , $V_{IN} - V_{OUT} = +1.5\text{ V}$
Minimum Load Current, $I_{L(MIN)}$			1.0	$\mu\text{A}$	
LBI Input Threshold					
Low Going	1.1	1.26		V	ADM666A
High Going		1.29	1.42	V	ADM666A
Hysteresis		30		mV	ADM666A
LBI Input Current, $I_{LBI}$		$\pm 0.01$	$\pm 10$	nA	ADM666A
LBO Output Saturation Resistance, $R_{SAT}$		20	30	$\Omega$	ADM666A, $I_{SAT} = 2\text{ mA}$
LBO Output Leakage Current		0.2		nA	ADM666A, LBI = 1.4 V
$V_{TC}$ Open Circuit Voltage, $V_{TC}$		0.9		V	ADM663A
$V_{TC}$ Sink Current, $I_{TC}$		8.0	2.0	mA	ADM663A
$V_{TC}$ Temperature Coefficient		+2.5		mV/ $^{\circ}\text{C}$	ADM663A

Specifications subject to change without notice.

## ABSOLUTE MAXIMUM RATINGS\*

( $T_A = +25^{\circ}\text{C}$  unless otherwise noted)

Input Voltage, $V_{IN}$	+18 V
Terminal Voltage (ADM663A) Pins 1, 3, 5, 6, 7 ..... (GND - 0.3 V) to ( $V_{IN} + 0.3\text{ V}$ ) (ADM666A) Pins 1, 2, 3, 5, 6 ..... (GND - 0.3 V) to ( $V_{IN} + 0.3\text{ V}$ ) (ADM663A) Pin 2 ..... (GND - 0.3 V) to ( $V_{OUT1} + 0.3\text{ V}$ ) (ADM666A) Pin 7 ..... (GND - 0.3 V) to +16.5 V	
Output Source Current (ADM663A, ADM666A) Pin 2	100 mA
(ADM663A) Pin 3	25 mA
Output Sink Current, Pin 7	-20 mA
Power Dissipation, N-8 (Derate 8.3 mW/ $^{\circ}\text{C}$ above +30 $^{\circ}\text{C}$ )	800 mW
$\theta_{JA}$ , Thermal Impedance	120 $^{\circ}\text{C}/\text{W}$

Power Dissipation, R-8	570 mW
(Derate 6 mW/ $^{\circ}\text{C}$ above +30 $^{\circ}\text{C}$ )	
$\theta_{JA}$ , Thermal Impedance	170 $^{\circ}\text{C}/\text{W}$
Operating Temperature Range	
Industrial (A Version)	-40 $^{\circ}\text{C}$ to +85 $^{\circ}\text{C}$
Storage Temperature Range	-65 $^{\circ}\text{C}$ to +150 $^{\circ}\text{C}$
Lead Temperature (Soldering, 10 sec)	+300 $^{\circ}\text{C}$
Vapor Phase (60 sec)	+215 $^{\circ}\text{C}$
Infrared (15 sec)	+220 $^{\circ}\text{C}$
ESD Rating	>5000 V

\*This is a stress rating only and functional operation of the device at these or any other conditions above those indicated in the operation sections of this specification is not implied. Exposure to absolute maximum rating conditions for extended periods of time may affect reliability.

## PIN FUNCTION DESCRIPTION

Mnemonic	Function
V <sub>OUT(1) (2)</sub>	Voltage Regulator Output(s).
V <sub>IN</sub>	Voltage Regulator Input.
SENSE	Current Limit Sense Input. (Referenced to V <sub>OUT(2)</sub> .) If not used, it should be connected to V <sub>OUT(2)</sub> .
GND	Ground Pin. Must be connected to 0 V.
LBI	Low Battery Detect Input. Compared with 1.3 V.
LBO	Low Battery Detect Output. Open Drain Output.
SHDN	Digital Input. May be used to disable the device so that the power consumption is minimized.
V <sub>SET</sub>	Voltage Setting Input. Connect to GND for +5 V output, to V <sub>IN</sub> for +3.3 V output or connect to external resistive divider for adjustable output.
V <sub>TC</sub>	Temperature-Proportional Voltage for negative TC Output.

## PIN CONFIGURATIONS DIP & SOIC

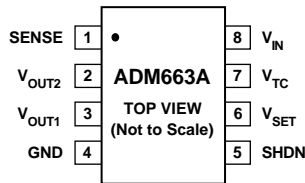

## DIP & SOIC

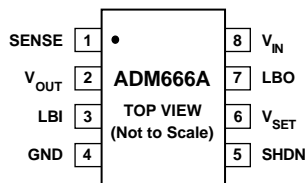

## ORDERING GUIDE

Model	Temperature Range	Package Option
ADM663AAN	-40°C to +85°C	N-8
ADM663AAR	-40°C to +85°C	R-8
ADM666AAN	-40°C to +85°C	N-8
ADM666AAR	-40°C to +85°C	R-8

## TERMINOLOGY

**Dropout Voltage:** The input/output voltage differential at which the regulator no longer maintains regulation against further reductions in input voltage. It is measured when the output decreases 100 mV from its nominal value. The nominal value is the measured value with  $V_{IN} = V_{OUT} + 2 \text{ V}$ .

**Line Regulation:** The change in output voltage as a result of a change in the input voltage. It is specified as a percentage change in output voltage for an input voltage change.

$$\text{Line Reg} = \frac{\Delta V_{OUT}}{V_{OUT}} (100)$$

**Load Regulation:** The change in output voltage for a change in output current.

$$\text{Load Reg} (\Omega) = \frac{\Delta V_{OUT}}{\Delta I_{OUT}}$$

**Quiescent Current:** The input bias current which flows when the regulator output is unloaded or when the regulator is in shutdown.

**Sense Input Threshold:** Current limit sense voltage. This is the voltage (referenced to V<sub>OUT(2)</sub>) at which current limiting occurs.

**Input-Output Saturation Resistance (ADM663A):** This is a measure of the internal MOS transistor effective resistance in series with V<sub>OUT1</sub>. The minimum input-output voltage differential at low currents may be calculated by multiplying the load current by the saturation resistance.

**Thermal Limiting:** This feature monitors the internal die temperature and disables the output when an internal temperature of 125°C is reached.

**Maximum Power Dissipation:** The maximum total device dissipation for which the regulator will continue to operate within specifications.

# ADM663A/ADM666A

## GENERAL INFORMATION

The ADM663A/ADM666A contains a micropower bandgap reference voltage source; an error amplifier, A1; three comparators, C1, C2, C3, and a series pass output transistor. A P-channel FET and an NPN transistor are used on the ADM663A while the ADM666A uses an NPN output transistor.

## CIRCUIT DESCRIPTION

The internal bandgap reference is trimmed to  $1.3\text{ V} \pm 30\text{ mV}$ . This is used as a reference input to the error amplifier A1. The feedback signal from the regulator output is supplied to the other input by an on-chip voltage divider or by two external resistors. When  $V_{SET}$  is at ground, the internal divider tap between R1 and R2, provides the error amplifier's feedback signal giving a +5 V output. When  $V_{SET}$  is at  $V_{IN}$ , the internal divider tap between R2 and R3 provides the error amplifier's feedback signal giving a +3.3 V output. When  $V_{SET}$  is at more than 50 mV above ground and less than 50 mV below  $V_{IN}$ , the error amplifier's input is switched directly to the  $V_{SET}$  pin, and external resistors are used to set the output voltage. The external resistors are selected so that the desired output voltage gives 1.3 V at  $V_{SET}$ .

Comparator C1 monitors the output current via the SENSE input. This input, referenced to  $V_{OUT(2)}$ , monitors the voltage drop across a load sense resistor. If the voltage drop exceeds 0.5 V, then the error amplifier A1 is disabled and the output current is limited.

The ADM663A has an additional amplifier, A2, which provides a temperature proportional output,  $V_{TC}$ . If this is summed into the inverting input of the error amplifier, a negative temperature coefficient results at the output. This is useful when powering liquid crystal displays over wide temperature ranges.

The ADM666A has an additional comparator, C4, that compares the voltage on the low battery input, LBI, pin to the internal +1.3 V reference. The output from the comparator drives an open drain FET connected to the low battery output pin, LBO. The low battery threshold may be set using a suitable voltage divider connected to LBI. When the voltage on LBI falls below 1.3 V, the open drain output LBO is pulled low.

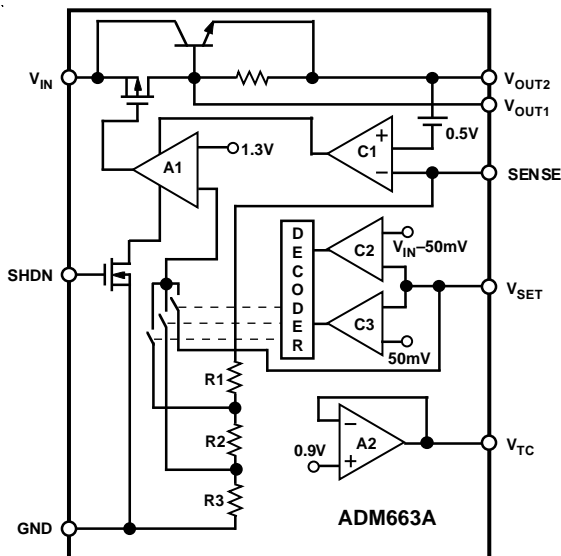

Figure 1. ADM663A Functional Block Diagram

Both the ADM663A and the ADM666A contain a shutdown (SHDN) input that can be used to disable the error amplifier and hence the voltage output. The power consumption in shutdown reduces to less than  $9\text{ }\mu\text{A}$ .

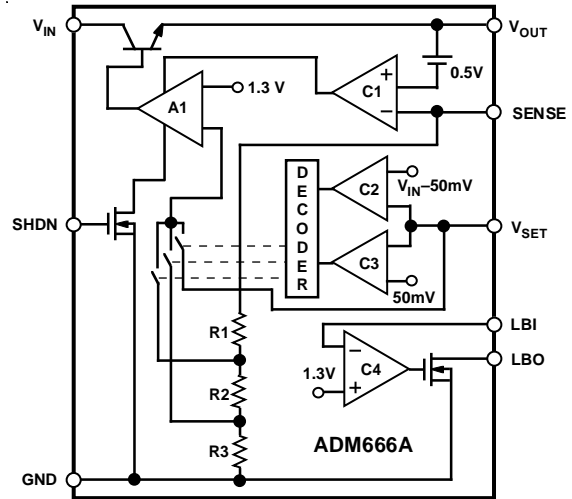

Figure 2. ADM666A Functional Block Diagram

## Circuit Configurations

For a fixed +5 V output the  $V_{SET}$  input is grounded and no external resistors are necessary. This basic configuration is shown in Figure 3. For a fixed +3.3 V output, the  $V_{SET}$  input is connected to  $V_{IN}$  as shown in Figure 4. Current limiting is not being utilized so the SENSE input is connected to  $V_{OUT(2)}$ .

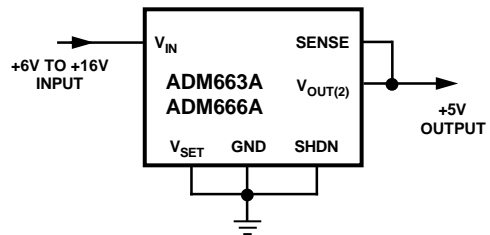

Figure 3. A Fixed +5 V Output

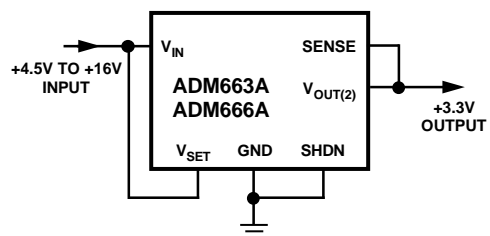

Figure 4. A Fixed +3.3 V Output

## Output Voltage Setting

If  $V_{SET}$  is not connected to GND or to  $V_{IN}$ , the output voltage is set according to the following equation:

$$V_{OUT} = V_{SET} \times \frac{(R1 + R2)}{R1}$$

where  $V_{SET} = 1.30\text{ V}$ .

The resistor values may be selected by first choosing a value for R1 and then selecting R2 according to the following equation:

$$R2 = R1 \times \left( \frac{V_{OUT}}{1.30} - 1 \right)$$

The input leakage current on V<sub>SET</sub> is 10 nA maximum. This allows large resistor values to be chosen for R1 and R2 with little degradation in accuracy. For example, a 1 MΩ resistor may be selected for R1, and then R2 may be calculated accordingly. The tolerance on V<sub>SET</sub> is guaranteed at less than ±30 mV so in most applications, fixed resistors will be suitable.

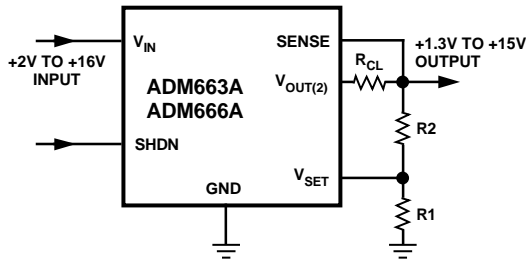

Figure 5. Adjustable Output

Table I. Output Voltage Selection

V <sub>SET</sub>	V <sub>OUT</sub>
GND	+5 V
V <sub>IN</sub>	+3 V
R1/R2	ADJ

### Current Limiting

Current limiting may be achieved by using an external current sense resistor in series with V<sub>OUT(2)</sub>. When the voltage across the sense resistor exceeds the internal 0.5 V threshold, current limiting is activated. The sense resistor is therefore chosen such that the voltage across it will be 0.5 V when the desired current limit is reached.

$$R_{CL} = \frac{0.5}{I_{CL}}$$

where R<sub>CL</sub> is the current sense resistor, I<sub>CL</sub> is the maximum current limit.

The value chosen for R<sub>CL</sub> should also ensure that the current is limited to less than the 100 mA absolute maximum rating and also that the power dissipation will also be within the package maximum ratings.

If current limiting is employed, there will be an additional voltage drop across the sense resistor that must be considered when determining the regulators dropout voltage.

If current limiting is not used, the SENSE input should be connected to V<sub>OUT(2)</sub>.

### Shutdown Input (SHDN)

The SHDN input allows the regulator to be turned off with a logic level signal. This will disable the output and reduce

the current drain to a low quiescent (9 μA maximum) current. This is very useful for low power applications. The SHDN input should be driven with a CMOS logic level signal since the input threshold is 0.3 V. In TTL systems, an open collector driver with a pull-up resistor may be used.

If the shutdown function is not being used, then it should be connected to GND.

### Low Supply or Low Battery Detection

The ADM666A contains on-chip circuitry for low power supply or battery detection. If the voltage on the LBI pin falls below the internal 1.3 V reference, then the open drain output LBO will go low. The low threshold voltage may be set to any voltage above 1.3 V by appropriate resistor divider selection.

$$R3 = R4 \left( \frac{V_{BATT}}{1.3 V} - 1 \right)$$

where R3 and R4 are the resistive divider resistors and V<sub>BATT</sub> is the desired low voltage threshold.

Since the LBI input leakage current is less than 10 nA, large values may be selected for R3 and R4 in order to minimize loading. For example, a 6 V low threshold may be set using 10 MΩ for R3 and 2.7 MΩ for R4.

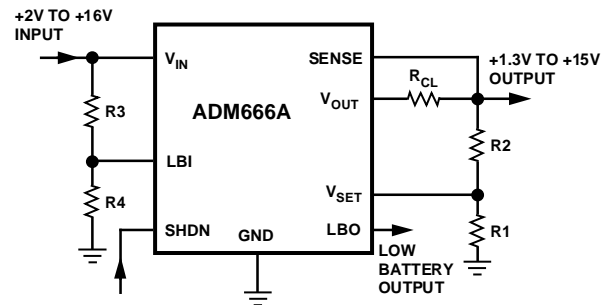

Figure 6. ADM666A Adjustable Output with Low Battery Detection

### High Current Operation

The ADM663A contains an additional output, V<sub>OUT1</sub>, suitable for directly driving the base of an external NPN transistor. Figure 7 shows a configuration which can be used to provide +5 V with boosted current drive. A 1 Ω current sensing resistor limits the current at 0.5 A.

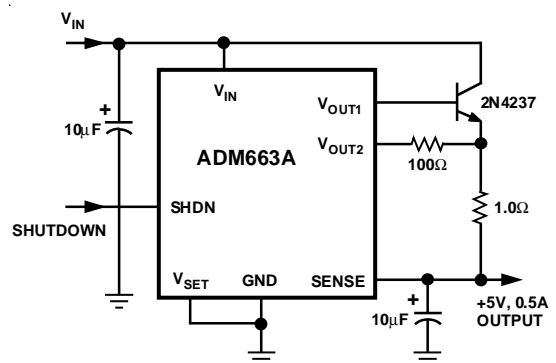

Figure 7. ADM663A Boosted Output Current (0.5 A)

# ADM663A/ADM666A

## Temperature Proportional Output

The ADM663A contains a  $V_{TC}$  output with a positive temperature coefficient of  $+2.5 \text{ mV}/^\circ\text{C}$ . This may be connected to the summing junction of the error amplifier ( $V_{SET}$ ) through a resistor resulting in a negative temperature coefficient at the output of the regulator. This is especially useful in multiplexed LCD displays to compensate for the inherent negative temperature coefficient of the LCD threshold. At  $+25^\circ\text{C}$  the voltage at the  $V_{TC}$  output is typically  $0.9 \text{ V}$ . The equations for setting both the output voltage and the tempco are given below. If this function is not being used, then  $V_{TC}$  should be left unconnected.

$$V_{OUT} = V_{SET} \left( 1 + \frac{R2}{R1} \right) + \frac{R2}{R3} (V_{SET} - V_{TC})$$

$$TCV_{OUT} = \frac{-R2}{R3} (TCV_{TC})$$

where  $V_{SET} = +1.3 \text{ V}$ ,  $V_{TC} = +0.9 \text{ V}$ ,  $TCV_{TC} = +2.5 \text{ mV}/^\circ\text{C}$

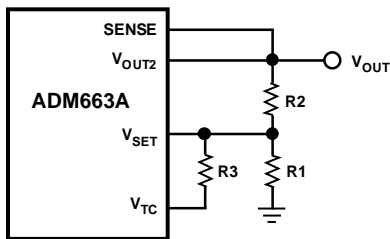

Figure 8. ADM663A Temperature Proportional Output

## APPLICATION HINTS

### Input-Output (Dropout Voltage)

A regulator's minimum input-output differential or dropout voltage determines the lowest input voltage for a particular output voltage. The ADM663A/ADM666A dropout voltage is  $1 \text{ V}$  at its rated output current. For example when used as a fixed  $+5 \text{ V}$  regulator, the minimum input voltage is  $+6 \text{ V}$ . At lower output currents ( $I_{OUT} < 10 \text{ mA}$ ) on the ADM663A,  $V_{OUT1}$  may be used as the output driver in order to achieve lower dropout voltages. In this case the dropout voltage depends on the voltage drop across the internal FET transistor. This may be calculated by multiplying the FET's saturation resistance by the output current, for example with  $V_{IN} = 9 \text{ V}$ ,  $R_{SAT} = 20 \Omega$ . Therefore, the dropout voltage for  $5 \text{ mA}$  is  $100 \text{ mV}$ . As the current limit circuitry is referenced to  $V_{OUT2}$ ,  $V_{OUT2}$  should be connected to  $V_{OUT1}$ . For high current operation  $V_{OUT2}$  should be used alone and  $V_{OUT1}$  left unconnected.

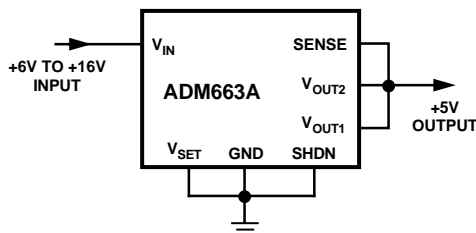

Figure 9. Low Current, Low Dropout Configuration

### Thermal Considerations

The ADM663A/ADM666A can supply up to  $100 \text{ mA}$  load current and can operate with input voltages up to  $16.5 \text{ V}$ , but the package power dissipation and hence the die temperature must

be kept within the maximum limits. The package power dissipation is calculated from the product of the voltage differential across the regulator times the current being supplied to the load. The power dissipation must be kept within the maximum limits given in the Absolute Maximum Ratings section.

$$P_D = (V_{IN} - V_{OUT})(I_L)$$

The die temperature is dependent on both the ambient temperature and on the power being dissipated by the device. The ADM663A/ADM666A contains an internal thermal limiting circuit which will shut down the regulator if the internal die temperature exceeds  $125^\circ\text{C}$ . Therefore, care must be taken to ensure that, under normal operating conditions, the die temperature is kept below the thermal limit.

$$T_j = T_A + P_D (\theta_{jA})$$

This may be expressed in terms of power dissipation as follows:

$$P_D = (T_j - T_A)/(\theta_{jA})$$

where:

$T_j$  = Die Junction Temperature ( $^\circ\text{C}$ )

$T_A$  = Ambient Temperature ( $^\circ\text{C}$ )

$P_D$  = Power Dissipation (W)

$\theta_{jA}$  = Junction to Ambient Thermal Resistance ( $^\circ\text{C}/\text{W}$ )

If the device is being operated at the maximum permitted ambient temperature of  $85^\circ\text{C}$  the maximum power dissipation permitted is:

$$P_D (max) = (T_j (max) - T_A)/(\theta_{jA})$$

$$P_D (max) = (125 - 85)/(\theta_{jA})$$

$$= 40/\theta_{jA}$$

$\theta_{jA} = 120^\circ\text{C}/\text{W}$  for the 8-pin DIP (N-8) package

$\theta_{jA} = 170^\circ\text{C}/\text{W}$  for the 8-pin SOIC (R-8) package

Therefore, for a maximum ambient temperature of  $85^\circ\text{C}$

$$P_D (max) = 333 \text{ mW for N-8}$$

$$P_D (max) = 235 \text{ mW for R-8}$$

At lower ambient temperatures the maximum permitted power dissipation increases accordingly up to the maximum limits specified in the absolute maximum specifications.

The thermal impedance ( $\theta_{jA}$ ) figures given are measured in still air conditions and are reduced considerably where fan assisted cooling is employed. Other techniques for reducing the thermal impedance include large contact pads on the printed circuit board and wide traces. The copper will act as a heat exchanger thereby reducing the effective thermal impedance.

### High Power Dissipation Recommendations

Where excessive power dissipation due to high input-output differential voltages and or high current conditions exists, the simplest method of reducing the power requirements on the regulator is to use a series dropper resistor. In this way the excess power can be dissipated in the external resistor. As an example, consider an input voltage of  $+12 \text{ V}$  and an output voltage requirement of  $+5 \text{ V}$  @  $100 \text{ mA}$  with an ambient temperature of  $+85^\circ\text{C}$ . The package power dissipation under these conditions is  $700 \text{ mW}$  which exceeds the maximum ratings. By using a dropper resistor to drop  $4 \text{ V}$ , the power dissipation requirement for the regulator is reduced to  $300 \text{ mW}$  which is within the maximum specifications for the N-8 package at

+85°C. The resistor value is calculated as  $R = 4/0.1 = 40 \Omega$ . A resistor power rating of 400 mW or greater may be used.

### Bypass Capacitors

The high frequency performance of the ADM663A/ADM666A may be improved by decoupling the output using a filter capacitor. A capacitor of 0.1  $\mu\text{F}$  is suitable.

An input capacitor helps reduce noise, improves dynamic performance and reduces the input  $dV/dt$  at the regulator input. A suitable input capacitor is 0.1  $\mu\text{F}$  or greater.

## Typical Performance Characteristics

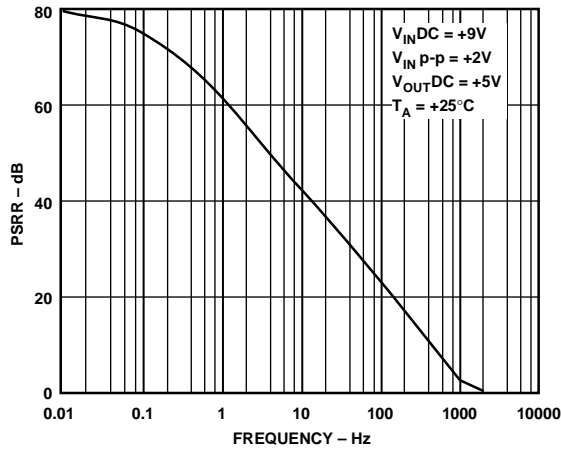

Figure 10. Power Supply Rejection Ratio vs. Frequency

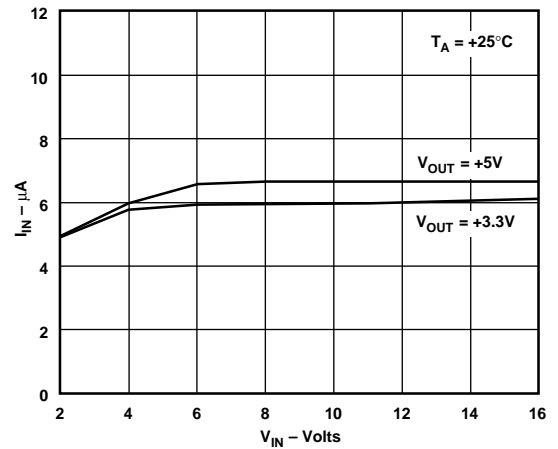

Figure 12. Quiescent Current vs. Input Voltage

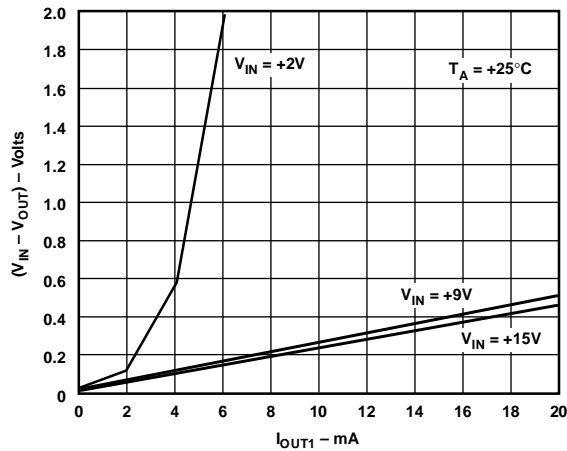

Figure 11.  $V_{OUT1}$  Input-Output Differential vs. Output Current

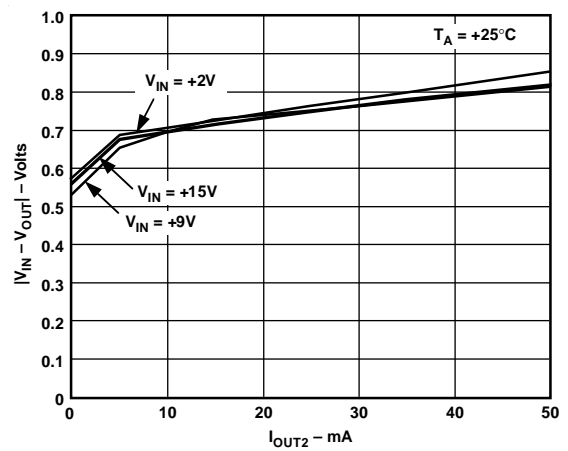

Figure 13.  $V_{OUT2}$  Input-Output Differential vs. Output Current

# ADM663A/ADM666A

## OUTLINE DIMENSIONS

Dimensions shown in inches and (mm).

### 8-Pin Plastic DIP

(N-8)

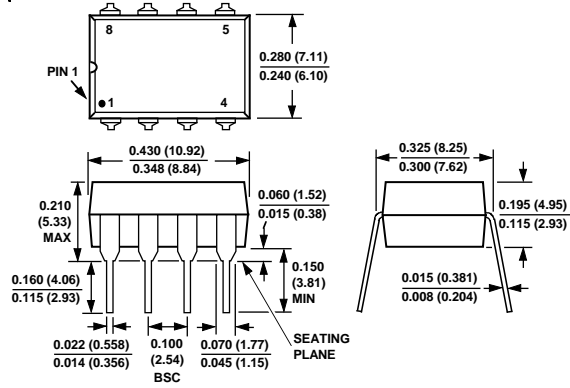

### 8-Terminal SO

(R-8)

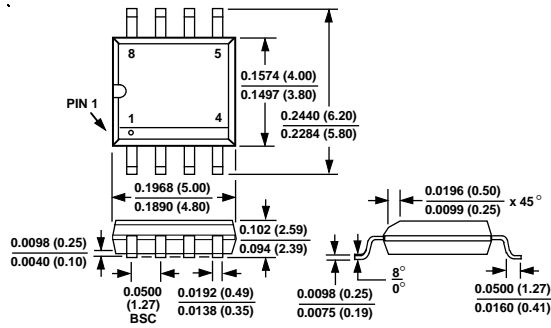

C.1939-18-7/94

PRINTED IN U.S.A.

**ORDERING GUIDE**

<b>Model</b>	<b>Temperature Range</b>	<b>Package Option*</b>
ADM663AAN	-40°C to +85°C	N-8
ADM663AAR	-40°C to +85°C	R-8
ADM666AAN	-40°C to +85°C	N-8
ADM666AAR	-40°C to +85°C	R-8

\*For outline information see Package Information section.



LittleDiode supplies new, hard to find or obsolete electronic components and semiconductors all over the world.

With over two million different components listed you are sure to find the part you need.

Feel free to visit us today at our online store:

[LittleDiode.com](http://LittleDiode.com)

Looking forward to providing you with the best possible service.