

CD54/74HC533, CD54/74HCT533, CD54/74HC563, CD74HCT563

High-Speed CMOS Logic Octal Inverting Transparent Latch, Three-State Outputs

Features

- Common Latch-Enable Control
- Common Three-State Output Enable Control
- Buffered Inputs
- Three-State Outputs
- Bus Line Driving Capacity
- Typical Propagation Delay = 13ns at $V_{CC} = 5V$, $C_L = 15pF$, $T_A = 25^\circ C$ (Data to Output)
- Fanout (Over Temperature Range)
 - Standard Outputs 10 LSTTL Loads
 - Bus Driver Outputs 15 LSTTL Loads
- Wide Operating Temperature Range . . . $-55^\circ C$ to $125^\circ C$
- Balanced Propagation Delay and Transition Times
- Significant Power Reduction Compared to LSTTL Logic ICs
- HC Types
 - 2V to 6V Operation
 - High Noise Immunity: $N_{IL} = 30\%$, $N_{IH} = 30\%$ of V_{CC} at $V_{CC} = 5V$
- HCT Types
 - 4.5V to 5.5V Operation
 - Direct LSTTL Input Logic Compatibility, $V_{IL} = 0.8V$ (Max), $V_{IH} = 2V$ (Min)
 - CMOS Input Compatibility, $I_I \leq 1\mu A$ at V_{OL} , V_{OH}

Description

The 'HC533, 'HCT533, 'HC563, and CD74HCT563 are high-speed Octal Transparent Latches manufactured with silicon gate CMOS technology. They possess the low power consumption of standard CMOS integrated circuits, as well as the ability to drive 15 LSTTL devices.

The outputs are transparent to the inputs when the latch enable (\overline{LE}) is high. When the latch enable (\overline{LE}) goes low the data is latched. The output enable (\overline{OE}) controls the three-state outputs. When the output enable (\overline{OE}) is high the outputs are in the high impedance state. The latch operation is independent of the state of the output enable.

The 'HC533 and 'HCT533 are identical in function to the 'HC563 and CD74HCT563 but have different pinouts. The 'HC533 and 'HCT533 are similar to the 'HC373 and 'HCT373; the latter are non-inverting types.

Ordering Information

| PART NUMBER | TEMP. RANGE ($^\circ C$) | PACKAGE |
|---------------|-------------------------------|--------------|
| CD54HC533F3A | -55 to 125 | 20 Ld CERDIP |
| CD54HC563F3A | -55 to 125 | 20 Ld CERDIP |
| CD54HCT533F3A | -55 to 125 | 20 Ld CERDIP |
| CD74HC533E | -55 to 125 | 20 Ld PDIP |
| CD74HC563E | -55 to 125 | 20 Ld PDIP |
| CD74HC563M | -55 to 125 | 20 Ld SOIC |
| CD74HCT533E | -55 to 125 | 20 Ld PDIP |
| CD74HCT563E | -55 to 125 | 20 Ld PDIP |
| CD74HCT563M | -55 to 125 | 20 Ld SOIC |

CD54/74HC533, CD54/74HCT533, CD54/74HC563, CD74HCT563

Pinouts

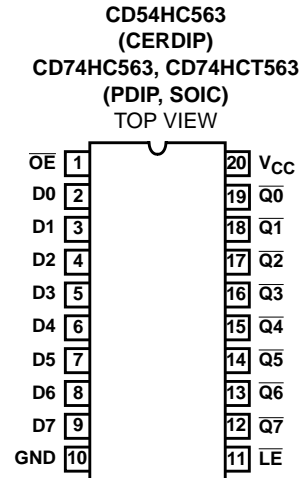
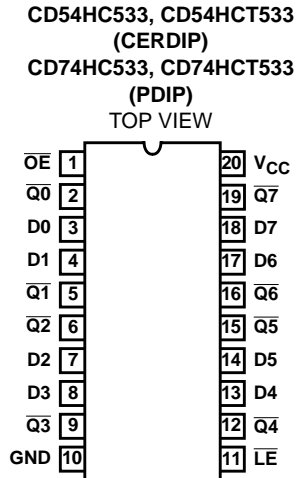

Functional Block Diagram

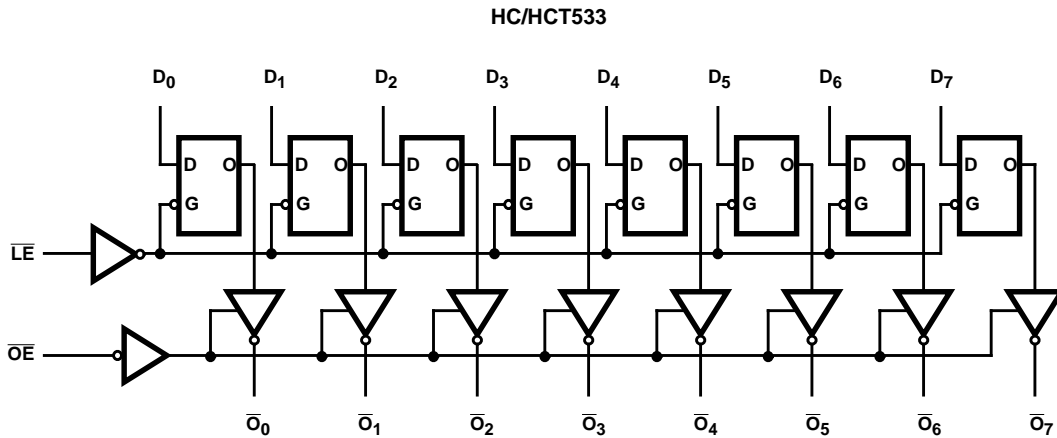

TRUTH TABLE

| OUTPUT ENABLE | LATCH ENABLE | DATA | Q OUTPUT |
|---------------|--------------|------|----------|
| L | H | H | L |
| L | H | L | H |
| L | L | l | H |
| L | L | h | L |
| H | X | X | Z |

H = High Voltage Level, L = Low Voltage Level, X = Don't Care, Z = High Impedance State, l = Low voltage level one set-up time prior to the high to low latch enable transition, h = High voltage level one set-up time prior to the high to low latch enable transition.

CD54/74HC533, CD54/74HCT533, CD54/74HC563, CD74HCT563

Absolute Maximum Ratings

| | |
|--|-------------|
| DC Supply Voltage, V_{CC} | -0.5V to 7V |
| DC Input Diode Current, I_{IK} | |
| For $V_I < -0.5V$ or $V_I > V_{CC} + 0.5V$ | $\pm 20mA$ |
| DC Output Diode Current, I_{OK} | |
| For $V_O < -0.5V$ or $V_O > V_{CC} + 0.5V$ | $\pm 20mA$ |
| DC Drain Current, per Output, I_O | |
| For $-0.5V < V_O < V_{CC} + 0.5V$ | $\pm 35mA$ |
| DC Output Source or Sink Current per Output Pin, I_O | |
| For $V_O > -0.5V$ or $V_O < V_{CC} + 0.5V$ | $\pm 25mA$ |
| DC V_{CC} or Ground Current, I_{CC} | $\pm 50mA$ |

Thermal Information

| | |
|--|---|
| Thermal Resistance (Typical, Note 1) | θ_{JA} ($^{\circ}C/W$) |
| E (PDIP) Package | 69 |
| M (SOIC) Package | 58 |
| Maximum Junction Temperature | $150^{\circ}C$ |
| Maximum Storage Temperature Range | $-65^{\circ}C$ to $150^{\circ}C$ |
| Maximum Lead Temperature (Soldering 10s) | $300^{\circ}C$ (SOIC - Lead Tips Only) |

Operating Conditions

| | |
|--|----------------------------------|
| Temperature Range, T_A | $-55^{\circ}C$ to $125^{\circ}C$ |
| Supply Voltage Range, V_{CC} | |
| HC Types | .2V to 6V |
| HCT Types | 4.5V to 5.5V |
| DC Input or Output Voltage, V_I, V_O | 0V to V_{CC} |
| Input Rise and Fall Time | |
| 2V | 1000ns (Max) |
| 4.5V | 500ns (Max) |
| 6V | 400ns (Max) |

CAUTION: Stresses above those listed in "Absolute Maximum Ratings" may cause permanent damage to the device. This is a stress only rating and operation of the device at these or any other conditions above those indicated in the operational sections of this specification is not implied.

NOTE:

- The package thermal impedance is calculated in accordance with JESD 51-7.

DC Electrical Specifications

| PARAMETER | SYMBOL | TEST CONDITIONS | | V_{CC} (V) | 25 $^{\circ}C$ | | | -40 $^{\circ}C$ TO 85 $^{\circ}C$ | | -55 $^{\circ}C$ TO 125 $^{\circ}C$ | | UNITS | |
|---|----------|-------------------------|------------|--------------|----------------|------|-----------|-----------------------------------|---------|------------------------------------|---------|---------|---|
| | | V_I (V) | I_O (mA) | | MIN | TYP | MAX | MIN | MAX | MIN | MAX | | |
| HC TYPES | | | | | | | | | | | | | |
| High Level Input Voltage | V_{IH} | - | - | 2 | 1.5 | - | - | 1.5 | - | 1.5 | - | V | |
| | | | | 4.5 | 3.15 | - | - | 3.15 | - | 3.15 | - | V | |
| | | | | 6 | 4.2 | - | - | 4.2 | - | 4.2 | - | V | |
| Low Level Input Voltage | V_{IL} | - | - | 2 | - | - | 0.5 | - | 0.5 | - | 0.5 | V | |
| | | | | 4.5 | - | - | 1.35 | - | 1.35 | - | 1.35 | V | |
| | | | | 6 | - | - | 1.8 | - | 1.8 | - | 1.8 | V | |
| High Level Output Voltage CMOS Loads | V_{OH} | V_{IH} or V_{IL} | -0.02 | -0.02 | 2 | 1.9 | - | - | 1.9 | - | 1.9 | - | V |
| | | | -0.02 | -0.02 | 4.5 | 4.4 | - | - | 4.4 | - | 4.4 | - | V |
| | | | -0.02 | -0.02 | 6 | 5.9 | - | - | 5.9 | - | 5.9 | - | V |
| High Level Output Voltage TTL Loads | V_{OH} | V_{IH} or V_{IL} | -6 | -6 | 4.5 | 3.98 | - | - | 3.84 | - | 3.7 | - | V |
| | | | -7.8 | -7.8 | 6 | 5.48 | - | - | 5.34 | - | 5.2 | - | V |
| Low Level Output Voltage CMOS Loads | V_{OL} | V_{IH} or V_{IL} | 0.02 | 0.02 | 2 | - | - | 0.1 | - | 0.1 | - | 0.1 | V |
| | | | 0.02 | 0.02 | 4.5 | - | - | 0.1 | - | 0.1 | - | 0.1 | V |
| | | | 0.02 | 0.02 | 6 | - | - | 0.1 | - | 0.1 | - | 0.1 | V |
| Low Level Output Voltage TTL Loads | V_{OL} | V_{IH} or V_{IL} | 6 | 6 | 4.5 | - | - | 0.26 | - | 0.33 | - | 0.4 | V |
| | | | 7.8 | 7.8 | 6 | - | - | 0.26 | - | 0.33 | - | 0.4 | V |
| Input Leakage Current | I_I | V_{CC} or GND | - | 6 | - | - | ± 0.1 | - | ± 1 | - | ± 1 | μA | |
| Quiescent Device Current | I_{CC} | V_{CC} or GND | 0 | 6 | - | - | 8 | - | 80 | - | 160 | μA | |

CD54/74HC533, CD54/74HCT533, CD54/74HC563, CD74HCT563

DC Electrical Specifications (Continued)

| PARAMETER | SYMBOL | TEST CONDITIONS | | V _{CC} (V) | 25°C | | | -40°C TO 85°C | | -55°C TO 125°C | | UNITS |
|--|---------------------------|------------------------------------|---|---------------------|------|-----|------|---------------|------|----------------|-----|-------|
| | | V _I (V) | I _O (mA) | | MIN | TYP | MAX | MIN | MAX | MIN | MAX | |
| Three-State Leakage Current | - | V _{IL} or V _{IH} | V _O = V _{CC} or GND | 6 | - | - | ±0.5 | - | ±5 | - | ±10 | μA |
| HCT TYPES | | | | | | | | | | | | |
| High Level Input Voltage | V _{IH} | - | - | 4.5 to 5.5 | 2 | - | - | 2 | - | 2 | - | V |
| Low Level Input Voltage | V _{IL} | - | - | 4.5 to 5.5 | - | - | 0.8 | - | 0.8 | - | 0.8 | V |
| High Level Output Voltage CMOS Loads | V _{OH} | V _{IH} or V _{IL} | -0.02 | 4.5 | 4.4 | - | - | 4.4 | - | 4.4 | - | V |
| High Level Output Voltage TTL Loads | | | -6 | 4.5 | 3.98 | - | - | 3.84 | - | 3.7 | - | V |
| Low Level Output Voltage CMOS Loads | V _{OL} | V _{IH} or V _{IL} | 0.02 | 4.5 | - | - | 0.1 | - | 0.1 | - | 0.1 | V |
| Low Level Output Voltage TTL Loads | | | 6 | 4.5 | - | - | 0.26 | - | 0.33 | - | 0.4 | V |
| Input Leakage Current | I _I | V _{CC} to GND | - | 5.5 | - | - | ±0.1 | - | ±1 | - | ±1 | μA |
| Quiescent Device Current | I _{CC} | V _{CC} or GND | 0 | 5.5 | - | - | 8 | - | 80 | - | 160 | μA |
| Three-State Leakage Current | - | V _{IL} or V _{IH} | V _O = V _{CC} or GND | 5.5 | - | - | ±0.5 | - | ±5 | - | ±10 | μA |
| Additional Quiescent Device Current Per Input Pin: 1 Unit Load | ΔI _{CC} (Note 2) | V _{CC} -2.1 | - | 4.5 to 5.5 | - | 100 | 360 | - | 450 | - | 490 | μA |

NOTE:

- For dual-supply systems theoretical worst case (V_I = 2.4V, V_{CC} = 5.5V) specification is 1.8mA.

HCT Input Loading Table

| INPUT | UNIT LOADS |
|-----------------|------------|
| D0 - D7 | 0.15 |
| \overline{LE} | 0.30 |
| \overline{OE} | 0.55 |

NOTE: Unit Load is ΔI_{CC} limit specified in DC Electrical Specifications table, e.g., 360μA max at 25°C.

CD54/74HC533, CD54/74HCT533, CD54/74HC563, CD74HCT563

Prerequisite For Switching Specifications

| PARAMETER | SYMBOL | TEST CONDITIONS | V _{CC} (V) | 25°C | | | -40°C TO 85°C | | -55°C TO 125°C | | UNITS |
|-----------------------------|-----------------|-----------------|---------------------|------|-----|-----|---------------|-----|----------------|-----|-------|
| | | | | MIN | TYP | MAX | MIN | MAX | MIN | MAX | |
| HC TYPES | | | | | | | | | | | |
| LE Pulse Width | t _w | - | 2 | 80 | - | - | 100 | - | 120 | - | ns |
| | | | 4.5 | 16 | - | - | 20 | - | 24 | - | ns |
| | | | 6 | 14 | - | - | 17 | - | 20 | - | ns |
| Set-up Time Data to LE | t _{SU} | - | 2 | 50 | - | - | 65 | - | 75 | - | ns |
| | | | 4.5 | 10 | - | - | 13 | - | 15 | - | ns |
| | | | 6 | 9 | - | - | 11 | - | 13 | - | ns |
| Hold Time, Data to LE (533) | t _H | - | 2 | 35 | - | - | 45 | - | 55 | - | ns |
| | | | 4.5 | 7 | - | - | 9 | - | 11 | - | ns |
| | | | 6 | 6 | - | - | 8 | - | 7 | - | ns |
| Hold Time, Data to LE (563) | t _H | - | 2 | 4 | - | - | 4 | - | 4 | - | ns |
| | | | 4.5 | 4 | - | - | 4 | - | 4 | - | ns |
| | | | 6 | 4 | - | - | 4 | - | 4 | - | ns |
| HCT TYPES | | | | | | | | | | | |
| LE Pulse Width | t _w | - | 4.5 | 16 | - | - | 20 | - | 24 | - | ns |
| Set-up Time Data to LE | t _w | - | 4.5 | 10 | - | - | 13 | - | 15 | - | ns |
| Hold Time, Data to LE (533) | t _H | - | 4.5 | 8 | - | - | 10 | - | 12 | - | ns |
| Hold Time, Data to LE (563) | t _H | - | 4.5 | 5 | - | - | 5 | - | 5 | - | ns |

Switching Specifications Input t_r, t_f = 6ns

| PARAMETER | SYMBOL | TEST CONDITIONS | V _{CC} (V) | 25°C | | -40°C TO 85°C | -55°C TO 125°C | UNITS |
|---------------------------------------|-------------------------------------|-----------------------|---------------------|------|-----|---------------|----------------|-------|
| | | | | TYP | MAX | MAX | MAX | |
| HC TYPES | | | | | | | | |
| Propagation Delay, Data to Qn (HC533) | t _{PLH} , t _{PHL} | C _L = 50pF | 2 | - | 165 | 205 | 250 | ns |
| | | | 4.5 | - | 33 | 41 | 50 | ns |
| | | C _L = 15pF | 6 | - | 28 | 35 | 43 | ns |
| | | | 5 | 13 | - | - | - | ns |
| Propagation Delay, Data to Qn (HC563) | t _{PLH} , t _{PHL} | C _L = 50pF | 2 | - | 150 | 190 | 225 | ns |
| | | | 4.5 | - | 30 | 38 | 45 | ns |
| | | C _L = 15pF | 6 | - | 26 | 33 | 38 | ns |
| | | | 5 | 12 | - | - | - | ns |
| Propagation Delay, LE to Qn (HC533) | t _{PLH} , t _{PHL} | C _L = 50pF | 2 | - | 175 | 220 | 265 | ns |
| | | | 4.5 | - | 35 | 44 | 53 | ns |
| | | C _L = 15pF | 6 | - | 30 | 37 | 45 | ns |
| | | | 5 | 14 | - | - | - | ns |
| Propagation Delay, LE to Qn (HC563) | t _{PLH} , t _{PHL} | C _L = 50pF | 2 | - | 165 | 205 | 250 | ns |
| | | | 4.5 | - | 33 | 41 | 50 | ns |
| | | C _L = 15pF | 6 | - | 28 | 35 | 43 | ns |
| | | | 5 | 13 | - | - | - | ns |

CD54/74HC533, CD54/74HCT533, CD54/74HC563, CD74HCT563

Switching Specifications Input $t_r, t_f = 6\text{ns}$ (Continued)

| PARAMETER | SYMBOL | TEST CONDITIONS | V_{CC} (V) | 25°C | | -40°C TO 85°C | -55°C TO 125°C | UNITS |
|--|--------------------------------------|---------------------|--------------|------|-----|---------------|----------------|-------|
| | | | | TYP | MAX | MAX | MAX | |
| Enable Times (HC533) | t_{PZH}, t_{PZL} | $C_L = 50\text{pF}$ | 2 | - | 150 | 190 | 225 | ns |
| | | | 4.5 | - | 30 | 38 | 45 | ns |
| | | | 6 | - | 26 | 33 | 38 | ns |
| | | $C_L = 15\text{pF}$ | 5 | 12 | - | - | - | ns |
| Disable Times (HC533) | t_{PHZ}, t_{PLZ} | $C_L = 50\text{pF}$ | 2 | - | 150 | 190 | 225 | ns |
| | | | 4.5 | - | 30 | 38 | 45 | ns |
| | | | 6 | - | 26 | 33 | 38 | ns |
| | | $C_L = 15\text{pF}$ | 5 | 12 | - | - | - | ns |
| Enable and Disable Times (HC563) | $t_{PZH}, t_{PZL}, t_{PHZ}, t_{PLZ}$ | $C_L = 50\text{pF}$ | 2 | - | 150 | 190 | 225 | ns |
| | | | 4.5 | - | 30 | 38 | 45 | ns |
| | | | 6 | - | 26 | 33 | 38 | ns |
| | | $C_L = 15\text{pF}$ | 5 | 12 | - | - | - | ns |
| Input Capacitance | C_I | - | - | - | 10 | 10 | 10 | pF |
| Three-State Output Capacitance | C_O | - | - | - | 20 | 20 | 20 | pF |
| Power Dissipation Capacitance (Notes 3, 4) | C_{PD} | - | 5 | 42 | - | - | - | pF |
| HCT TYPES | | | | | | | | |
| Propagation Delay, Data to Qn (HC/HCT533) | t_{PLH}, t_{PHL} | $C_L = 50\text{pF}$ | 4.5 | - | 34 | 43 | 51 | ns |
| | | $C_L = 15\text{pF}$ | 5 | 14 | - | - | - | ns |
| Propagation Delay, Data to Qn (HC/HCT563) | t_{PLH}, t_{PHL} | $C_L = 50\text{pF}$ | 4.5 | - | 30 | 38 | 45 | ns |
| | | $C_L = 15\text{pF}$ | 5 | 12 | - | - | - | ns |
| Propagation Delay, \overline{LE} to Qn (HC/HCT533) | t_{PLH}, t_{PHL} | $C_L = 50\text{pF}$ | 4.5 | - | 38 | 48 | 57 | ns |
| | | $C_L = 15\text{pF}$ | 5 | 16 | - | - | - | ns |
| Propagation Delay, \overline{LE} to Qn (HC/HCT563) | t_{PZL}, t_{PZH} | $C_L = 50\text{pF}$ | 4.5 | - | 35 | 44 | 53 | ns |
| | | $C_L = 15\text{pF}$ | 5 | 14 | - | - | - | ns |
| Enable Times (HC/HCT533) | t_{PLZ}, t_{PZH} | $C_L = 50\text{pF}$ | 4.5 | - | 35 | 44 | 53 | ns |
| | | $C_L = 15\text{pF}$ | 5 | 14 | - | - | - | ns |
| Disable Times (HC/HCT533) | t_{TLH}, t_{THL} | $C_L = 50\text{pF}$ | 4.5 | - | 30 | 38 | 45 | ns |
| | | $C_L = 15\text{pF}$ | 5 | 12 | - | - | - | ns |
| Enable and Disable Times (HC/HCT563) | $t_{PZH}, t_{PZL}, t_{PHZ}, t_{PLZ}$ | $C_L = 50\text{pF}$ | 4.5 | - | 35 | 44 | 53 | ns |
| | | $C_L = 15\text{pF}$ | 5 | 14 | - | - | - | ns |
| Input Capacitance | C_I | - | - | - | 10 | 10 | 10 | pF |
| Power Dissipation Capacitance (Notes 3, 4) | C_{PD} | - | 5 | 42 | - | - | - | pF |

NOTES:

- C_{PD} is used to determine the no-load dynamic power consumption, per latch.
- P_D (total power per latch) = $C_{PD} V_{CC}^2 f_i + \sum C_L V_{CC}^2 f_o$ where f_i = Input Frequency, f_o = Output Frequency, C_L = Output Load Capacitance, V_{CC} = Supply Voltage.

Test Circuits and Waveforms

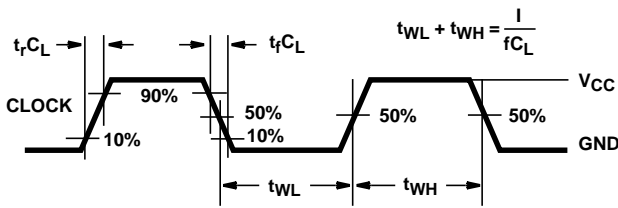

NOTE: Outputs should be switching from 10% V_{CC} to 90% V_{CC} in accordance with device truth table. For f_{MAX} , input duty cycle = 50%.

FIGURE 1. HC CLOCK PULSE RISE AND FALL TIMES AND PULSE WIDTH

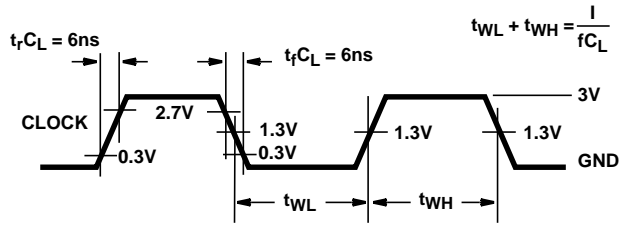

NOTE: Outputs should be switching from 10% V_{CC} to 90% V_{CC} in accordance with device truth table. For f_{MAX} , input duty cycle = 50%.

FIGURE 2. HCT CLOCK PULSE RISE AND FALL TIMES AND PULSE WIDTH

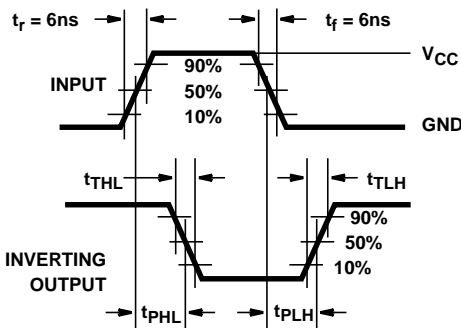

FIGURE 3. HC TRANSITION TIMES AND PROPAGATION DELAY TIMES, COMBINATION LOGIC

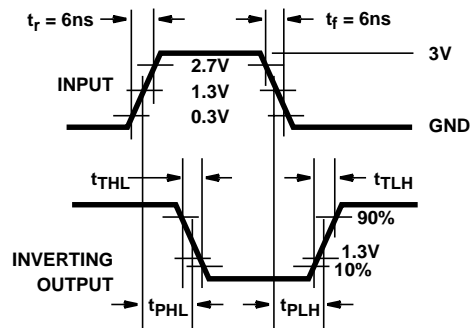

FIGURE 4. HCT TRANSITION TIMES AND PROPAGATION DELAY TIMES, COMBINATION LOGIC

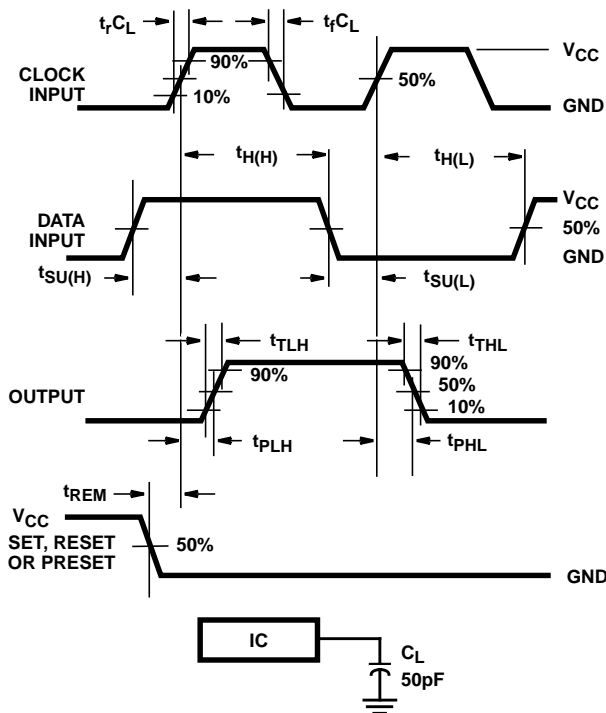

FIGURE 5. HC SETUP TIMES, HOLD TIMES, REMOVAL TIME, AND PROPAGATION DELAY TIMES FOR EDGE TRIGGERED SEQUENTIAL LOGIC CIRCUITS

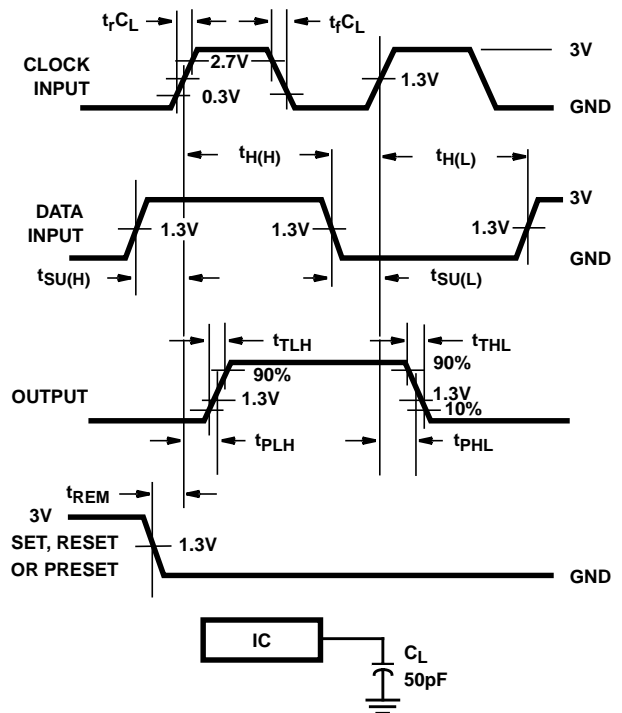

FIGURE 6. HCT SETUP TIMES, HOLD TIMES, REMOVAL TIME, AND PROPAGATION DELAY TIMES FOR EDGE TRIGGERED SEQUENTIAL LOGIC CIRCUITS

Test Circuits and Waveforms (Continued)

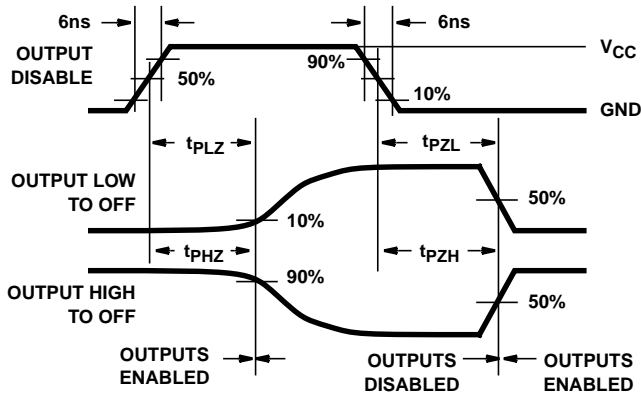

FIGURE 7. HC THREE-STATE PROPAGATION DELAY WAVEFORM

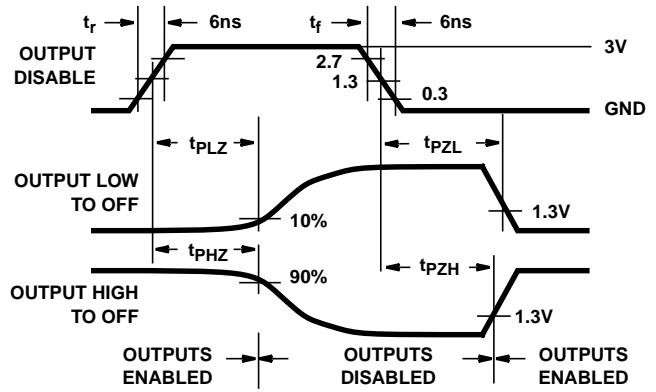
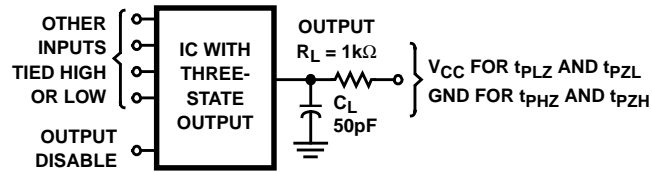

FIGURE 8. HCT THREE-STATE PROPAGATION DELAY WAVEFORM



NOTE: Open drain waveforms t_{PLZ} and t_{PZL} are the same as those for three-state shown on the left. The test circuit is Output $R_L = 1k\Omega$ to V_{CC} , $C_L = 50pF$.

FIGURE 9. HC AND HCT THREE-STATE PROPAGATION DELAY TEST CIRCUIT

PACKAGING INFORMATION

| Orderable Device | Status ⁽¹⁾ | Package Type | Package Drawing | Pins | Package Qty | Eco Plan ⁽²⁾ | Lead/Ball Finish | MSL Peak Temp ⁽³⁾ |
|------------------|-----------------------|--------------|-----------------|------|-------------|-------------------------|------------------|--|
| 5962-8606201RA | ACTIVE | CDIP | J | 20 | 1 | None | Call TI | Level-NC-NC-NC |
| 5962-8681301RA | ACTIVE | CDIP | J | 20 | 1 | None | Call TI | Level-NC-NC-NC |
| CD54HC533F3A | ACTIVE | CDIP | J | 20 | 1 | None | Call TI | Level-NC-NC-NC |
| CD54HC563F3A | ACTIVE | CDIP | J | 20 | 1 | None | Call TI | Level-NC-NC-NC |
| CD54HCT533F3A | ACTIVE | CDIP | J | 20 | 1 | None | Call TI | Level-NC-NC-NC |
| CD74HC533E | ACTIVE | PDIP | N | 20 | 20 | Pb-Free (RoHS) | CU NIPDAU | Level-NC-NC-NC |
| CD74HC563E | ACTIVE | PDIP | N | 20 | 20 | Pb-Free (RoHS) | CU NIPDAU | Level-NC-NC-NC |
| CD74HC563M | ACTIVE | SOIC | DW | 20 | 25 | Pb-Free (RoHS) | CU NIPDAU | Level-2-250C-1 YEAR/ Level-1-235C-UNLIM |
| CD74HCT533E | ACTIVE | PDIP | N | 20 | 20 | Pb-Free (RoHS) | CU NIPDAU | Level-NC-NC-NC |
| CD74HCT563E | ACTIVE | PDIP | N | 20 | 20 | Pb-Free (RoHS) | CU NIPDAU | Level-NC-NC-NC |
| CD74HCT563M | ACTIVE | SOIC | DW | 20 | 25 | Pb-Free (RoHS) | CU NIPDAU | Level-2-250C-1 YEAR/ Level-1-235C-UNLIM |

⁽¹⁾ The marketing status values are defined as follows:

ACTIVE: Product device recommended for new designs.

LIFEBUY: TI has announced that the device will be discontinued, and a lifetime-buy period is in effect.

NRND: Not recommended for new designs. Device is in production to support existing customers, but TI does not recommend using this part in a new design.

PREVIEW: Device has been announced but is not in production. Samples may or may not be available.

OBsolete: TI has discontinued the production of the device.

⁽²⁾ Eco Plan - May not be currently available - please check <http://www.ti.com/productcontent> for the latest availability information and additional product content details.

None: Not yet available Lead (Pb-Free).

Pb-Free (RoHS): TI's terms "Lead-Free" or "Pb-Free" mean semiconductor products that are compatible with the current RoHS requirements for all 6 substances, including the requirement that lead not exceed 0.1% by weight in homogeneous materials. Where designed to be soldered at high temperatures, TI Pb-Free products are suitable for use in specified lead-free processes.

Green (RoHS & no Sb/Br): TI defines "Green" to mean "Pb-Free" and in addition, uses package materials that do not contain halogens, including bromine (Br) or antimony (Sb) above 0.1% of total product weight.

⁽³⁾ MSL, Peak Temp. -- The Moisture Sensitivity Level rating according to the JEDEC industry standard classifications, and peak solder temperature.

Important Information and Disclaimer: The information provided on this page represents TI's knowledge and belief as of the date that it is provided. TI bases its knowledge and belief on information provided by third parties, and makes no representation or warranty as to the accuracy of such information. Efforts are underway to better integrate information from third parties. TI has taken and continues to take reasonable steps to provide representative and accurate information but may not have conducted destructive testing or chemical analysis on incoming materials and chemicals. TI and TI suppliers consider certain information to be proprietary, and thus CAS numbers and other limited information may not be available for release.

In no event shall TI's liability arising out of such information exceed the total purchase price of the TI part(s) at issue in this document sold by TI to Customer on an annual basis.

J (R-GDIP-T**)

14 LEADS SHOWN

CERAMIC DUAL IN-LINE PACKAGE

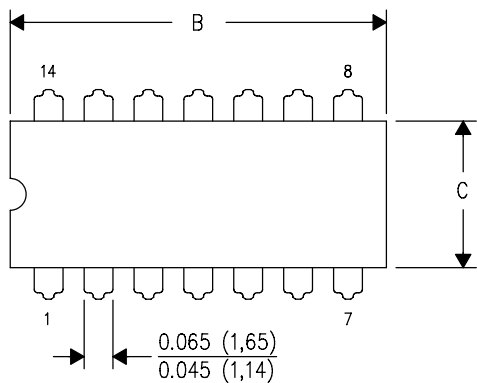

| DIM \ PINS ** | 14 | 16 | 18 | 20 |
|---------------|------------------------|------------------------|------------------------|------------------------|
| A | 0.300 (7,62) BSC | 0.300 (7,62) BSC | 0.300 (7,62) BSC | 0.300 (7,62) BSC |
| B MAX | 0.785 (19,94) | .840 (21,34) | 0.960 (24,38) | 1.060 (26,92) |
| B MIN | — | — | — | — |
| C MAX | 0.300 (7,62) | 0.300 (7,62) | 0.310 (7,87) | 0.300 (7,62) |
| C MIN | 0.245 (6,22) | 0.245 (6,22) | 0.220 (5,59) | 0.245 (6,22) |

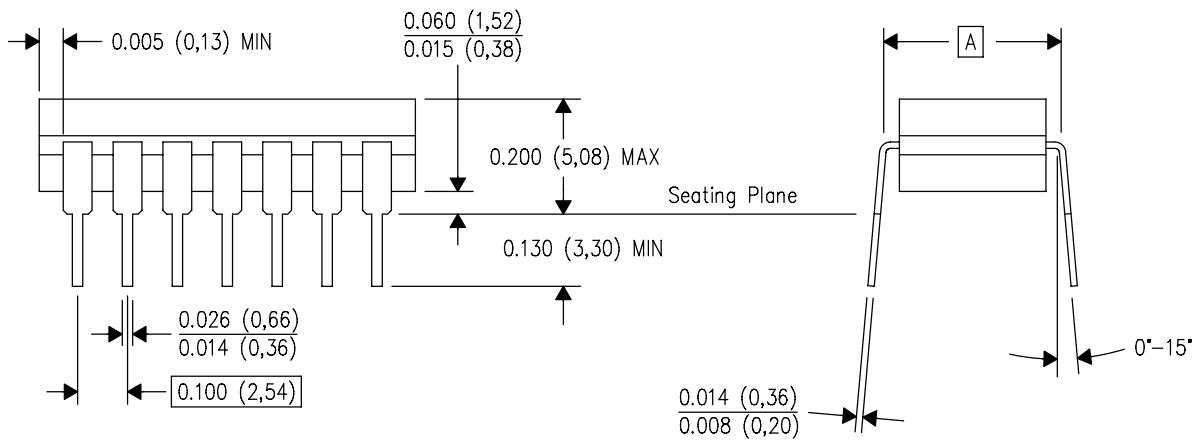

4040083/F 03/03

- NOTES:
- All linear dimensions are in inches (millimeters).
 - This drawing is subject to change without notice.
 - This package is hermetically sealed with a ceramic lid using glass frit.
 - Index point is provided on cap for terminal identification only on press ceramic glass frit seal only.
 - Falls within MIL STD 1835 GDIP1-T14, GDIP1-T16, GDIP1-T18 and GDIP1-T20.

N (R-PDIP-T**)

PLASTIC DUAL-IN-LINE PACKAGE

16 PINS SHOWN

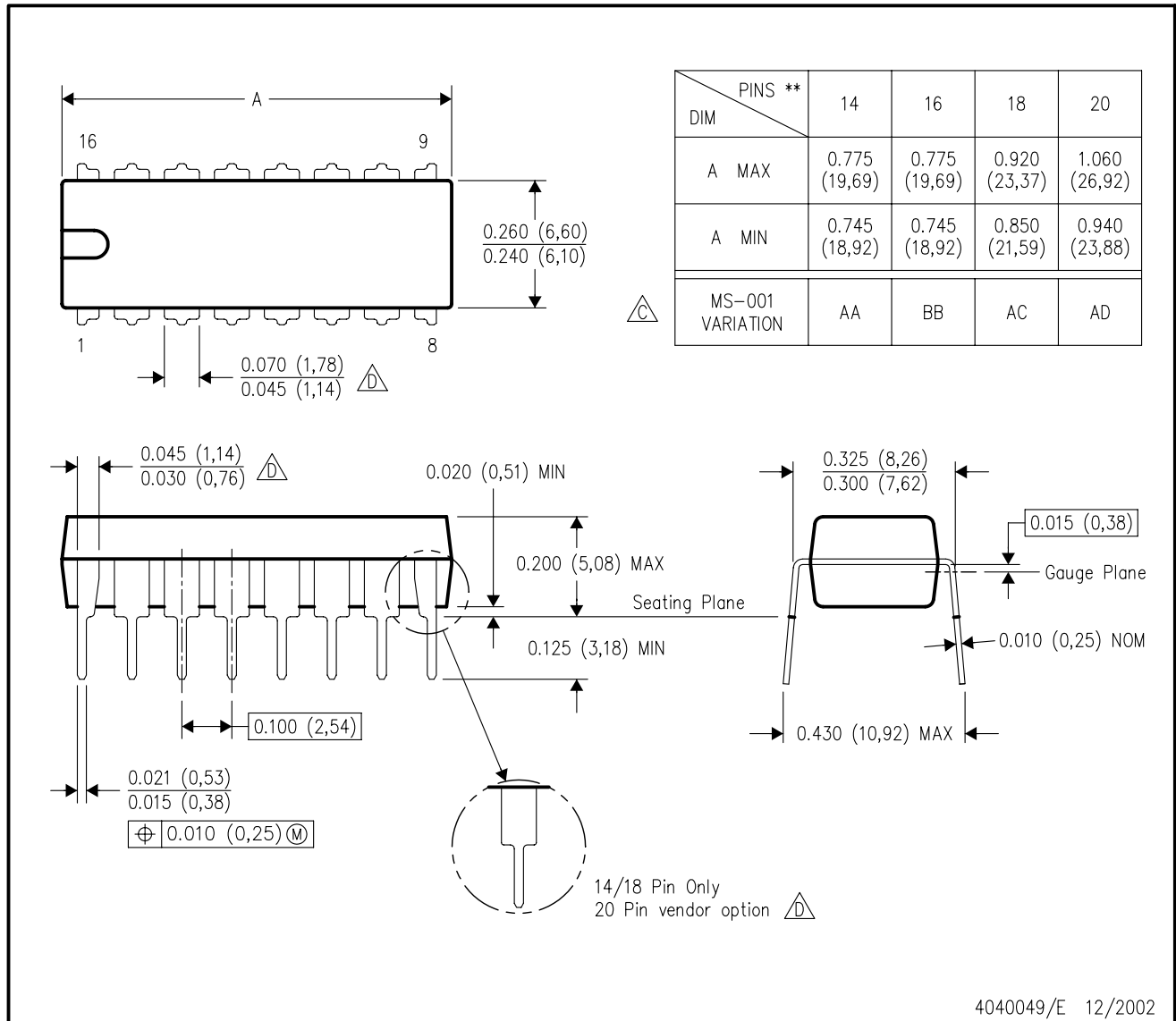

- NOTES:
- A. All linear dimensions are in inches (millimeters).
 - B. This drawing is subject to change without notice.
 - Falls within JEDEC MS-001, except 18 and 20 pin minimum body length (Dim A).
 - The 20 pin end lead shoulder width is a vendor option, either half or full width.

DW (R-PDSO-G20)

PLASTIC SMALL-OUTLINE PACKAGE

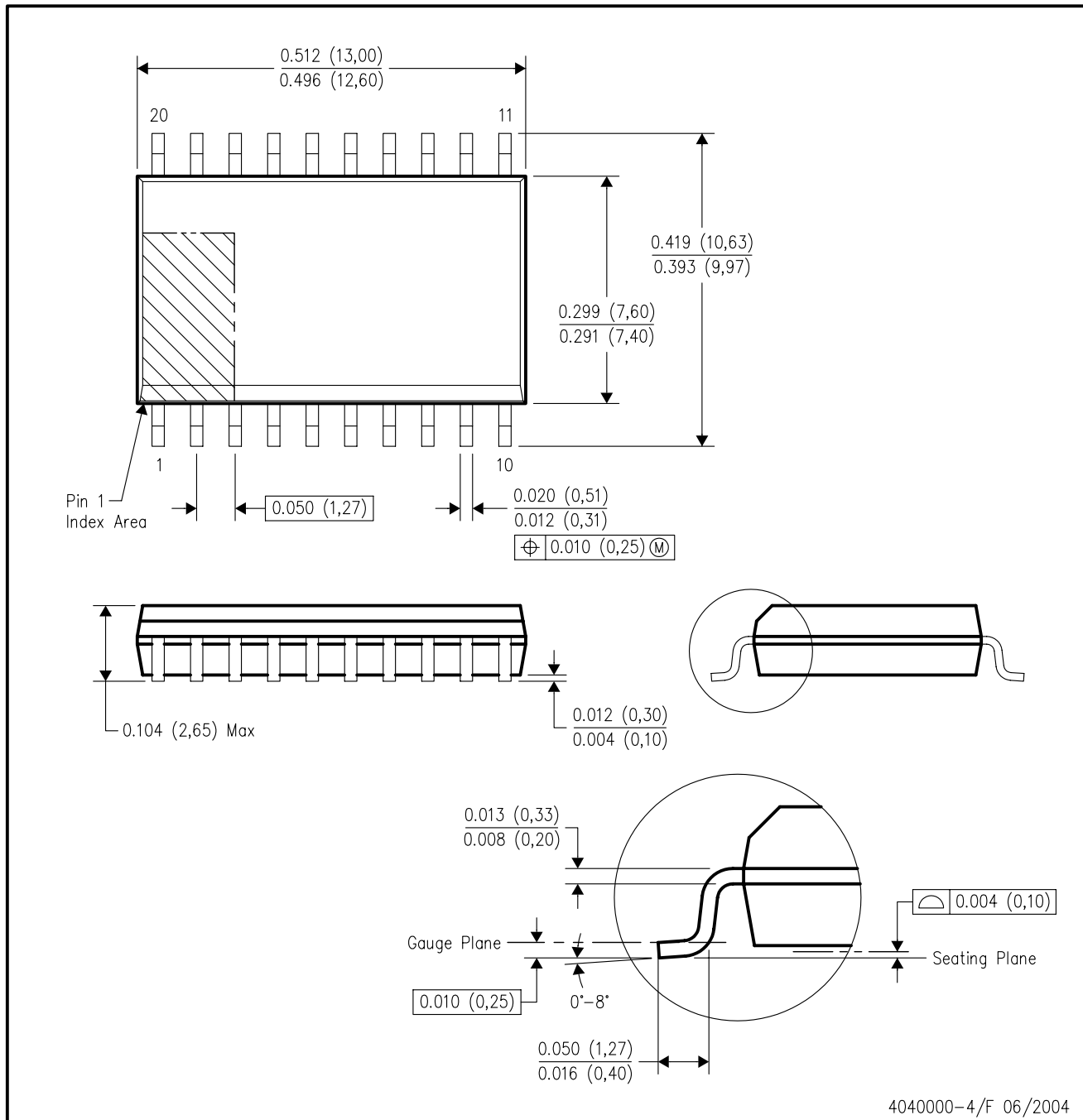

- NOTES:
- A. All linear dimensions are in inches (millimeters).
 - B. This drawing is subject to change without notice.
 - C. Body dimensions do not include mold flash or protrusion not to exceed 0.006 (0,15).
 - D. Falls within JEDEC MS-013 variation AC.

IMPORTANT NOTICE

Texas Instruments Incorporated and its subsidiaries (TI) reserve the right to make corrections, modifications, enhancements, improvements, and other changes to its products and services at any time and to discontinue any product or service without notice. Customers should obtain the latest relevant information before placing orders and should verify that such information is current and complete. All products are sold subject to TI's terms and conditions of sale supplied at the time of order acknowledgment.

TI warrants performance of its hardware products to the specifications applicable at the time of sale in accordance with TI's standard warranty. Testing and other quality control techniques are used to the extent TI deems necessary to support this warranty. Except where mandated by government requirements, testing of all parameters of each product is not necessarily performed.

TI assumes no liability for applications assistance or customer product design. Customers are responsible for their products and applications using TI components. To minimize the risks associated with customer products and applications, customers should provide adequate design and operating safeguards.

TI does not warrant or represent that any license, either express or implied, is granted under any TI patent right, copyright, mask work right, or other TI intellectual property right relating to any combination, machine, or process in which TI products or services are used. Information published by TI regarding third-party products or services does not constitute a license from TI to use such products or services or a warranty or endorsement thereof. Use of such information may require a license from a third party under the patents or other intellectual property of the third party, or a license from TI under the patents or other intellectual property of TI.

Reproduction of information in TI data books or data sheets is permissible only if reproduction is without alteration and is accompanied by all associated warranties, conditions, limitations, and notices. Reproduction of this information with alteration is an unfair and deceptive business practice. TI is not responsible or liable for such altered documentation.

Resale of TI products or services with statements different from or beyond the parameters stated by TI for that product or service voids all express and any implied warranties for the associated TI product or service and is an unfair and deceptive business practice. TI is not responsible or liable for any such statements.

Following are URLs where you can obtain information on other Texas Instruments products and application solutions:

| Products | | Applications | |
|------------------|--|---------------------|--|
| Amplifiers | amplifier.ti.com | Audio | www.ti.com/audio |
| Data Converters | dataconverter.ti.com | Automotive | www.ti.com/automotive |
| DSP | dsp.ti.com | Broadband | www.ti.com/broadband |
| Interface | interface.ti.com | Digital Control | www.ti.com/digitalcontrol |
| Logic | logic.ti.com | Military | www.ti.com/military |
| Power Mgmt | power.ti.com | Optical Networking | www.ti.com/opticalnetwork |
| Microcontrollers | microcontroller.ti.com | Security | www.ti.com/security |
| | | Telephony | www.ti.com/telephony |
| | | Video & Imaging | www.ti.com/video |
| | | Wireless | www.ti.com/wireless |

Mailing Address: Texas Instruments
Post Office Box 655303 Dallas, Texas 75265

Texas Instruments

<http://www.ti.com>

This file is the datasheet for the following electronic components:

CD54HC533F3A - <http://www.ti.com/product/cd54hc533f3a?HQS=TI-null-null-dscatalog-df-pf-null-wwe>
5962-8681301RA - <http://www.ti.com/product/5962-8681301ra?HQS=TI-null-null-dscatalog-df-pf-null-wwe>
CD74HCT533E - <http://www.ti.com/product/cd74hct533e?HQS=TI-null-null-dscatalog-df-pf-null-wwe>
CD74HCT563M - <http://www.ti.com/product/cd74hct563m?HQS=TI-null-null-dscatalog-df-pf-null-wwe>
CD54HC533 - <http://www.ti.com/product/cd54hc533?HQS=TI-null-null-dscatalog-df-pf-null-wwe>
CD74HC533E - <http://www.ti.com/product/cd74hc533e?HQS=TI-null-null-dscatalog-df-pf-null-wwe>
CD74HC533 - <http://www.ti.com/product/cd74hc533?HQS=TI-null-null-dscatalog-df-pf-null-wwe>
CD74HCT533 - <http://www.ti.com/product/cd74hct533?HQS=TI-null-null-dscatalog-df-pf-null-wwe>
CD74HCT563E - <http://www.ti.com/product/cd74hct563e?HQS=TI-null-null-dscatalog-df-pf-null-wwe>
5962-8606201RA - <http://www.ti.com/product/5962-8606201ra?HQS=TI-null-null-dscatalog-df-pf-null-wwe>
CD54HCT533 - <http://www.ti.com/product/cd54hct533?HQS=TI-null-null-dscatalog-df-pf-null-wwe>
CD54HC563 - <http://www.ti.com/product/cd54hc563?HQS=TI-null-null-dscatalog-df-pf-null-wwe>
CD74HC563E - <http://www.ti.com/product/cd74hc563e?HQS=TI-null-null-dscatalog-df-pf-null-wwe>
CD54HCT533F3A - <http://www.ti.com/product/cd54hct533f3a?HQS=TI-null-null-dscatalog-df-pf-null-wwe>
CD74HC563 - <http://www.ti.com/product/cd74hc563?HQS=TI-null-null-dscatalog-df-pf-null-wwe>
CD54HC563F3A - <http://www.ti.com/product/cd54hc563f3a?HQS=TI-null-null-dscatalog-df-pf-null-wwe>
CD74HCT563 - <http://www.ti.com/product/cd74hct563?HQS=TI-null-null-dscatalog-df-pf-null-wwe>
CD74HC563M - <http://www.ti.com/product/cd74hc563m?HQS=TI-null-null-dscatalog-df-pf-null-wwe>



LittleDiode supplies new, hard to find or obsolete electronic components and semiconductors all over the world.

With over two million different components listed you are sure to find the part you need.

Feel free to visit us today at our online store:

LittleDiode.com

Looking forward to providing you with the best possible service.