

200MHz Low-Power Current Feedback Amplifiers



The EL5160, EL5161, EL5260, EL5261, and EL5360 are current feedback amplifiers with a bandwidth of 200MHz and operate from just 0.75mA supply current. This makes these amplifiers ideal for today's high speed video and monitor applications.

With the ability to run from a single supply voltage from 5V to 10V, these amplifiers are ideal for handheld, portable, or battery-powered equipment.

The EL5160 also incorporates an enable and disable function to reduce the supply current to 14 μ A typical per amplifier. Allowing the CE pin to float or applying a low logic level will enable the amplifier.

The EL5160 is available in the 6-pin SOT-23 and 8-pin SO packages, the EL5161 in 5-pin SOT-23 and SC-70 packages, the EL5260 in the 10-pin MSOP package, the EL5261 in 8-pin SO and MSOP packages, the EL5360 in 16-pin SO and QSOP packages. All operate over the industrial temperature range of -40°C to +85°C.

Features

- 200MHz -3dB bandwidth
- 0.75mA supply current
- 1700V/ μ s slew rate
- Single and dual supply operation, from 5V to 10V supply span
- Fast enable/disable (EL5160, EL5260 & EL5360 only)
- Available in SOT-23 packages
- Pb-free Available as an Option

Applications

- Battery-powered equipment
- Handheld, portable devices
- Video amplifiers
- Cable drivers
- RGB amplifiers
- Test equipment
- Instrumentation
- Current to voltage converters

Pinouts

EL5160
(8-PIN SO)
TOP VIEW

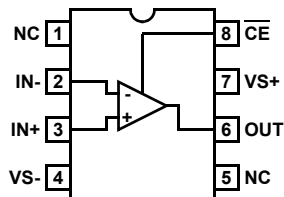

EL5160
(6-PIN SOT-23)
TOP VIEW

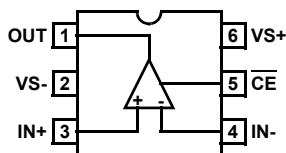

EL5161
(5-PIN SOT-23, SC-70)
TOP VIEW

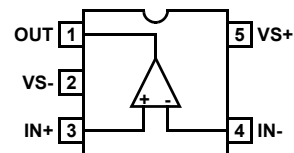

EL5260
(10-PIN MSOP)
TOP VIEW

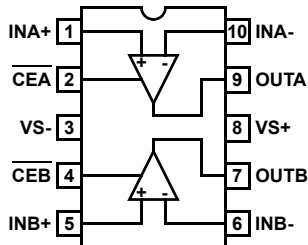

EL5261
(8-PIN SO, MSOP)
TOP VIEW

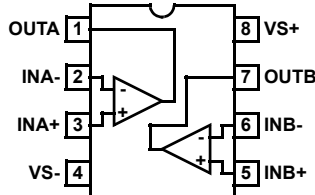

EL5360
(16-PIN SO, QSOP)
TOP VIEW

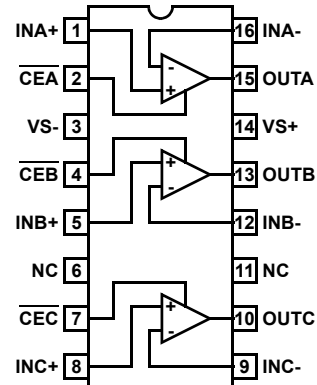

Ordering Information

PART NUMBER	PACKAGE	TAPE & REEL	PKG. DWG. #
EL5160IS	8-Pin SO (0.150")	-	MDP0027
EL5160ISZ (See Note)	8-Pin SO (0.150") (Pb-free)	-	MDP0027
EL5160IS-T7	8-Pin SO (0.150")	7"	MDP0027
EL5160ISZ-T7 (See Note)	8-Pin SO (0.150") (Pb-free)	7"	MDP0027
EL5160IS-T13	8-Pin SO (0.150")	13"	MDP0027
EL5160ISZ-T13 (See Note)	8-Pin SO (0.150") (Pb-free)	13"	MDP0027
EL5160IW-T7	6-Pin SOT-23	7" (3K pcs)	MDP0038
EL5160IWZ-T7 (See Note)	6-Pin SOT-23 (Pb-free)	7" (3K pcs)	MDP0038
EL5160IW-T7A	6-Pin SOT-23	7" (250 pcs)	MDP0038
EL5160IWZ-T7A (See Note)	6-Pin SOT-23 (Pb-free)	7" (250 pcs)	MDP0038
EL5161IW-T7	5-Pin SOT-23	7" (3K pcs)	MDP0038
EL5161IWZ-T7 (See Note)	5-Pin SOT-23 (Pb-free)	7" (3K pcs)	MDP0038
EL5161IW-T7A	5-Pin SOT-23	7" (250 pcs)	MDP0038
EL5161IWZ-T7A (See Note)	5-Pin SOT-23 (Pb-free)	7" (250 pcs)	MDP0038
EL5161IC-T7	5-Pin SC-70	7" (3K pcs)	P5.049
EL5161ICZ-T7 (See Note)	5-Pin SC-70 (Pb-free)	7" (3K pcs)	P5.049
EL5161IC-T7A	5-Pin SC-70	7" (250 pcs)	P5.049
EL5161ICZ-T7A (See Note)	5-Pin SC-70 (Pb-free)	7" (250 pcs)	P5.049
EL5260IY	10-Pin MSOP	-	MDP0043
EL5260IY-T7	10-Pin MSOP	7"	MDP0043
EL5260IY-T13	10-Pin MSOP	13"	MDP0043
EL5261IY	8-Pin MSOP	-	MDP0043
EL5261IY-T7	8-Pin MSOP	7"	MDP0043
EL5261IY-T13	8-Pin MSOP	13"	MDP0043
EL5261IS	8-Pin SO (0.150")	-	MDP0027
EL5261IS-T7	8-Pin SO (0.150")	7"	MDP0027
EL5261IS-T13	8-Pin SO (0.150")	13"	MDP0027
EL5360IS	16-Pin SO (0.150")	-	MDP0027
EL5360ISZ (See Note)	16-Pin SO (0.150") (Pb-free)	-	MDP0027
EL5360IS-T7	16-Pin SO (0.150")	7"	MDP0027
EL5360ISZ-T7 (See Note)	16-Pin SO (0.150") (Pb-free)	7"	MDP0027

Ordering Information (Continued)

PART NUMBER	PACKAGE	TAPE & REEL	PKG. DWG. #
EL5360IS-T13	16-Pin SO (0.150")	13"	MDP0027
EL5360ISZ-T13 (See Note)	16-Pin SO (0.150") (Pb-free)	13"	MDP0027
EL5360IU	16-Pin QSOP	-	MDP0040
EL5360IUZ (See Note)	16-Pin QSOP (Pb-free)	-	MDP0040
EL5360IU-T7	16-Pin QSOP	7"	MDP0040
EL5360IUZ-T7 (See Note)	16-Pin QSOP (Pb-free)	7"	MDP0040
EL5360IU-T13	16-Pin QSOP	13"	MDP0040
EL5360IUZ-T13 (See Note)	16-Pin QSOP (Pb-free)	13"	MDP0040

NOTE: Intersil Pb-free products employ special Pb-free material sets; molding compounds/die attach materials and 100% matte tin plate termination finish, which is compatible with both SnPb and Pb-free soldering operations. Intersil Pb-free products are MSL classified at Pb-free peak reflow temperatures that meet or exceed the Pb-free requirements of IPC/JEDEC J Std-020B.

EL5160, EL5161, EL5260, EL5261, EL5360

Absolute Maximum Ratings ($T_A = 25^\circ\text{C}$)

Supply Voltage between V_{S+} and V_{S-}	13.2V	Power Dissipation	See Curves
Maximum Continuous Output Current	50mA	Storage Temperature	-65°C to +150°C
Operating Junction Temperature	125°C	Ambient Operating Temperature	-40°C to +85°C
Pin Voltages	$V_{S-} - 0.5\text{V}$ to $V_{S+} + 0.5\text{V}$		

CAUTION: Stresses above those listed in "Absolute Maximum Ratings" may cause permanent damage to the device. This is a stress only rating and operation of the device at these or any other conditions above those indicated in the operational sections of this specification is not implied.

IMPORTANT NOTE: All parameters having Min/Max specifications are guaranteed. Typical values are for information purposes only. Unless otherwise noted, all tests are at the specified temperature and are pulsed tests, therefore: $T_J = T_C = T_A$

Electrical Specifications $V_{S+} = +5\text{V}$, $V_{S-} = -5\text{V}$, $R_F = 750\Omega$ for $A_V = 1$, $R_L = 150\Omega$, $V_{CE, H} = V_{S+}$, $V_{CE, L} = (V_{S+}) - 3\text{V}$, $T_A = 25^\circ\text{C}$, Unless Otherwise Specified.

PARAMETER	DESCRIPTION	CONDITIONS	MIN	TYP	MAX	UNIT
AC PERFORMANCE						
BW	-3dB Bandwidth	$A_V = +1$, $R_L = 500\Omega$		200		MHz
		$A_V = +2$, $R_L = 150\Omega$		125		MHz
BW1	0.1dB Bandwidth	$R_L = 100\Omega$		10		MHz
SR	Slew Rate	$V_O = -2.5\text{V}$ to $+2.5\text{V}$, $A_V = +2$, $R_F = R_G = 1\text{k}\Omega$, $R_L = 100\Omega$	900	1700	2500	V/ μs
SR	500 Ω Load			1360		V/ μs
t_S	0.1% Settling Time	$V_{OUT} = -2.5\text{V}$ to $+2.5\text{V}$, $A_V = +2$		35		ns
e_N	Input Voltage Noise			4		nV/ $\sqrt{\text{Hz}}$
i_{N-}	IN- Input Current Noise			7		pA/ $\sqrt{\text{Hz}}$
i_{N+}	IN+ Input Current Noise			8		pA/ $\sqrt{\text{Hz}}$
HD2		5MHz, 2.5V _{P-P} , $R_L = 150\Omega$, $A_V = +2$		-74		dBc
HD3		5MHz, 2.5V _{P-P} , $R_L = 150\Omega$, $A_V = +2$		-50		dBc
dG	Differential Gain Error (Note 1)	$A_V = +2$		0.1		%
dP	Differential Phase Error (Note 1)	$A_V = +2$		0.1		°
DC PERFORMANCE						
V_{OS}	Offset Voltage		-5	1.6	+5	mV
$T_C V_{OS}$	Input Offset Voltage Temperature Coefficient	Measured from T_{MIN} to T_{MAX}		6		$\mu\text{V}/^\circ\text{C}$
R_{OL}	Transimpedance	$\pm 2.5V_{OUT}$ into 150 Ω	800	2000		k Ω
INPUT CHARACTERISTICS						
CMIR	Common Mode Input Range	Guaranteed by CMRR test	± 3	± 3.3		V
CMRR	Common Mode Rejection Ratio	$V_{IN} = \pm 3\text{V}$	50	62	75	dB
-ICMR	- Input Current Common Mode Rejection		-1		+1	$\mu\text{A}/\text{V}$
+ I_{IN}	+ Input Current		-4		+4	μA
- I_{IN}	- Input Current		-5		+5	μA
R_{IN}	Input Resistance		1.5	4	15	M Ω
C_{IN}	Input Capacitance			1		pF

EL5160, EL5161, EL5260, EL5261, EL5360

Electrical Specifications $V_{S+} = +5V$, $V_{S-} = -5V$, $R_F = 750\Omega$ for $A_V = 1$, $R_L = 150\Omega$, $V_{CE, H} = V_{S+}$, $V_{CE, L} = (V_{S+}) - 3V$, $T_A = 25^\circ C$, Unless Otherwise Specified. **(Continued)**

PARAMETER	DESCRIPTION	CONDITIONS	MIN	TYP	MAX	UNIT
OUTPUT CHARACTERISTICS						
V_O	Output Voltage Swing	$R_L = 150\Omega$ to GND	± 3.1	± 3.4	± 3.8	V
		$R_L = 1k\Omega$ to GND	± 3.8	± 4.0	± 4.2	V
I_{OUT}	Output Current	$R_L = 10\Omega$ to GND	40	70	140	mA
SUPPLY						
I_{SON}	Supply Current - Enabled, per Amplifier	No load, $V_{IN} = 0V$ (EL5160, EL5161, EL5260, EL5261)	0.6	0.75	0.85	mA
		No load, $V_{IN} = 0V$ (EL5360)	0.65	0.8	0.92	mA
I_{SOFF+}	Supply Current - Disabled, per Amplifier		0	1	25	μA
I_{SOFF-}	Supply Current - Disabled, per Amplifier	No load, $V_{IN} = 0V$	-25	-14	0	μA
PSRR	Power Supply Rejection Ratio	DC, $V_S = \pm 4.75V$ to $\pm 5.25V$	65	74		dB
-IPSR	- Input Current Power Supply Rejection	DC, $V_S = \pm 4.75V$ to $\pm 5.25V$	-0.5	0.1	0.5	$\mu A/V$
ENABLE (EL5160, EL5260, EL5360 ONLY)						
t_{EN}	Enable Time			600		ns
t_{DIS}	Disable Time			800		ns
$I_{CE, H}$	\overline{CE} Pin Input High Current	$\overline{CE} = V_{S+}$	1	14	25	μA
$I_{CE, L}$	\overline{CE} Pin Input Low Current	$\overline{CE} = (V_{S+}) - 5V$	-1	0	1	μA

NOTE:

- Standard NTSC test, AC signal amplitude = 286mV_{p-p}, f = 3.58MHz

Typical Performance Curves

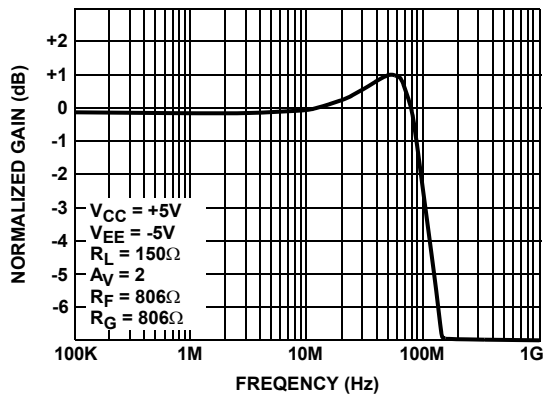

FIGURE 1. FREQUENCY RESPONSE

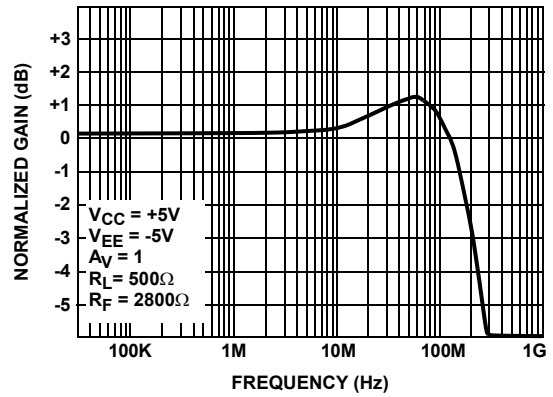

FIGURE 2. FREQUENCY RESPONSE

Typical Performance Curves (Continued)

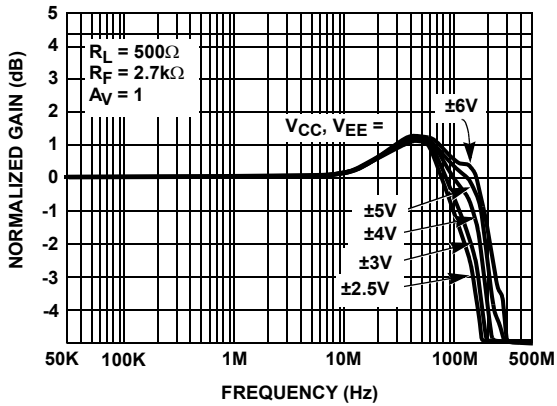

FIGURE 3. FREQUENCY RESPONSE FOR VARIOUS V_{CC}, V_{EE}

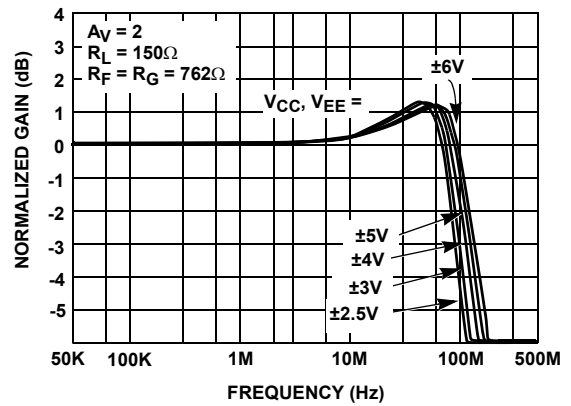

FIGURE 4. FREQUENCY RESPONSE FOR VARIOUS V_{CC}, V_{EE}

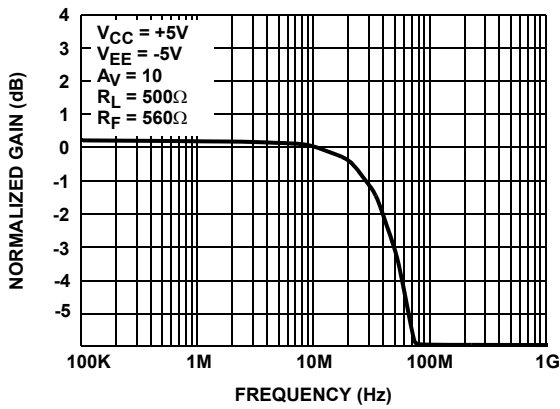

FIGURE 5. FREQUENCY RESPONSE

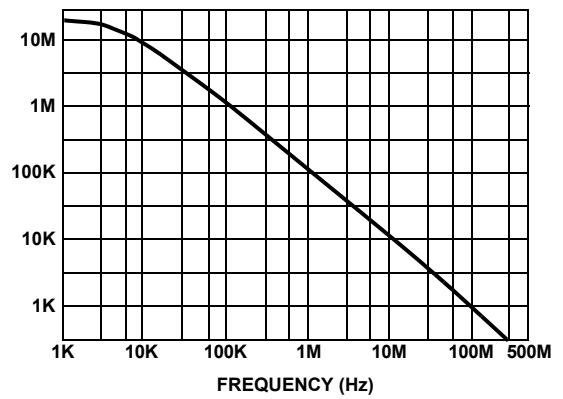

FIGURE 6. R_{OL}

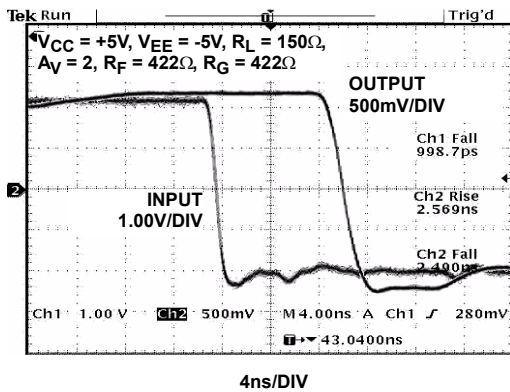

FIGURE 7. FALL TIME

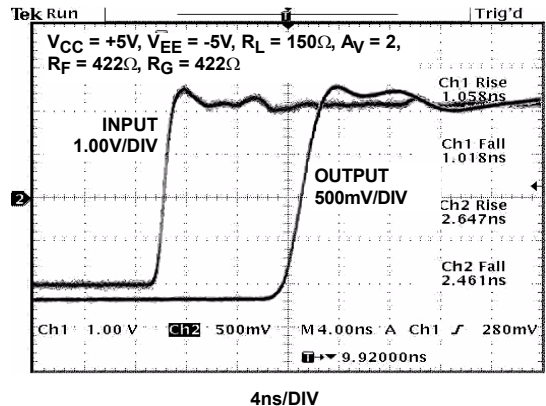

FIGURE 8. RISE TIME

Typical Performance Curves (Continued)

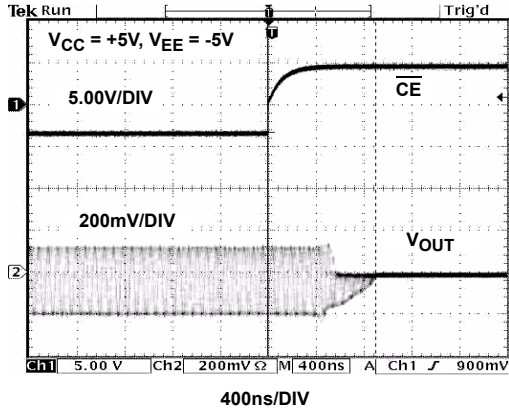

FIGURE 9. DISABLE DELAY TIME

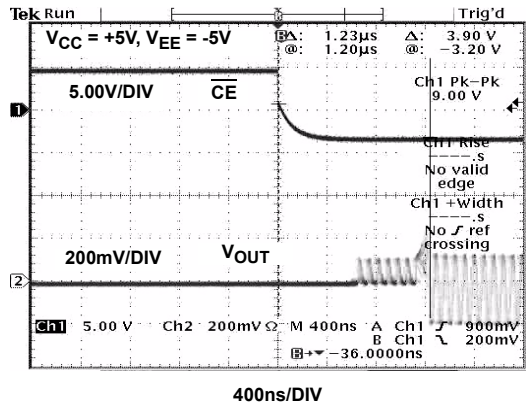

FIGURE 10. ENABLE DELAY TIME

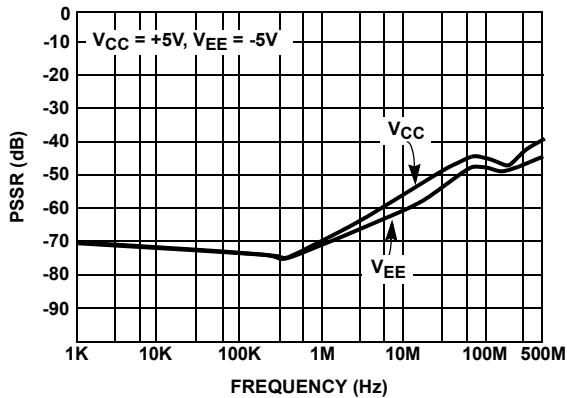

FIGURE 11. PSSR

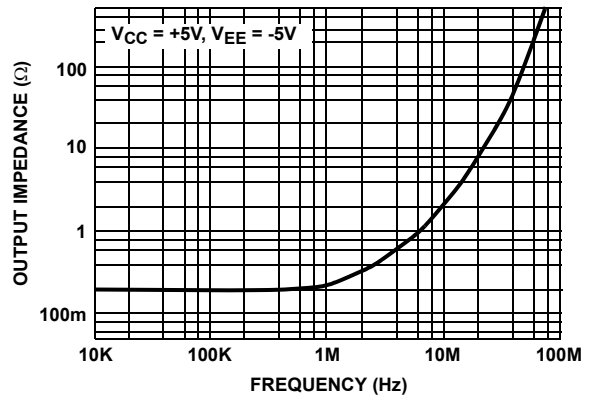

FIGURE 12. CLOSED LOOP OUTPUT IMPEDANCE

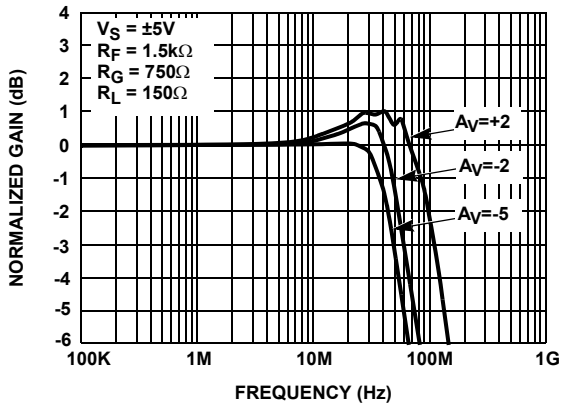

FIGURE 13. FREQUENCY RESPONSE FOR VARIOUS GAIN SETTINGS

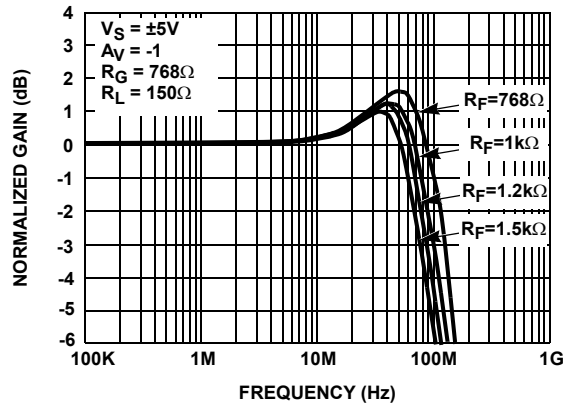

FIGURE 14. FREQUENCY RESPONSE FOR VARIOUS FEEDBACK RESISTORS, $A_v = -1$

Typical Performance Curves (Continued)

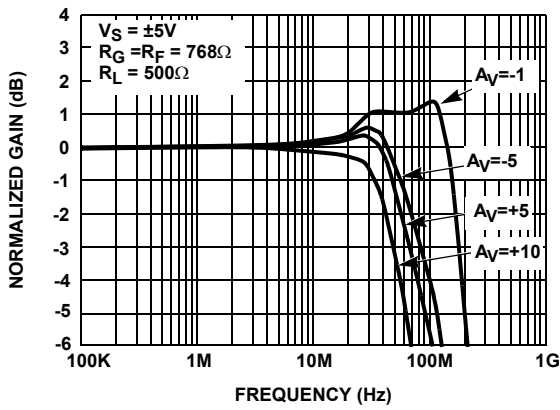

FIGURE 15. FREQUENCY RESPONSE FOR VARIOUS GAIN SETTINGS

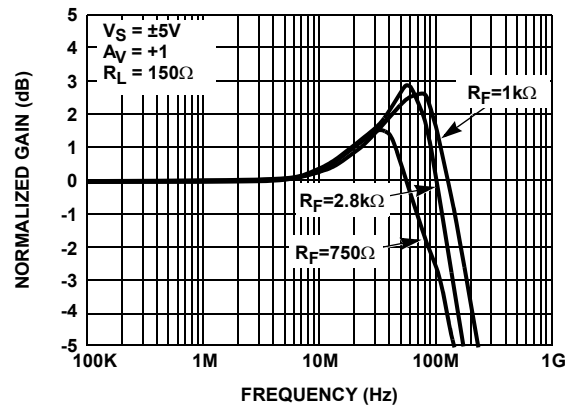

FIGURE 16. FREQUENCY RESPONSE FOR VARIOUS FEEDBACK RESISTORS, $A_V = +1$

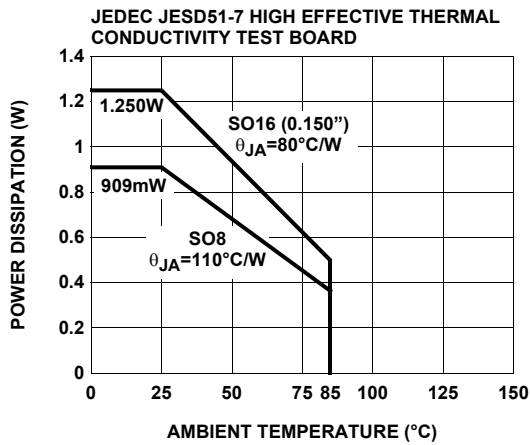

FIGURE 17. PACKAGE POWER DISSIPATION vs AMBIENT TEMPERATURE

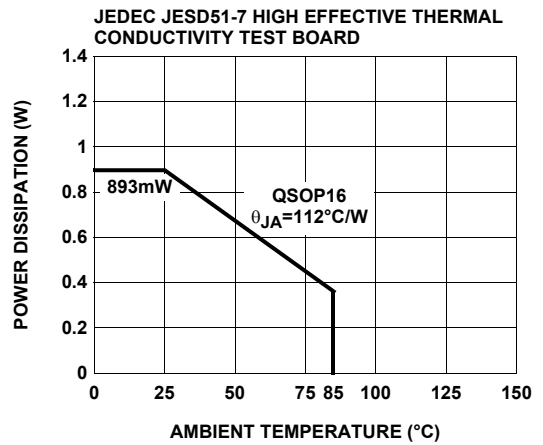

FIGURE 18. PACKAGE POWER DISSIPATION vs AMBIENT TEMPERATURE

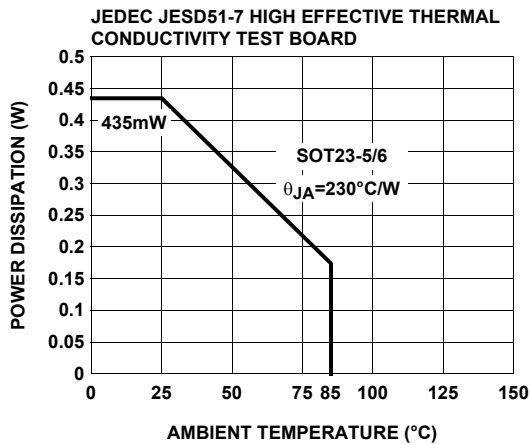

FIGURE 19. PACKAGE POWER DISSIPATION vs AMBIENT TEMPERATURE

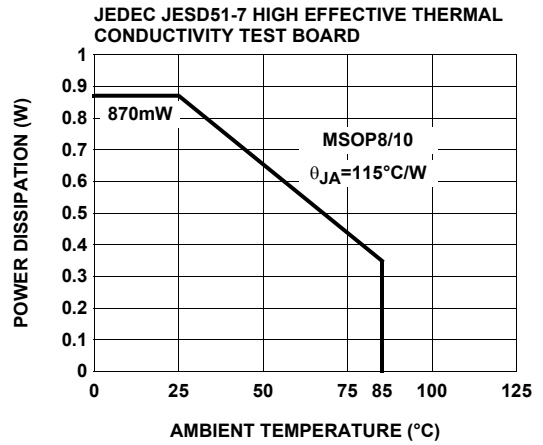

FIGURE 20. PACKAGE POWER DISSIPATION vs AMBIENT TEMPERATURE

Typical Performance Curves (Continued)

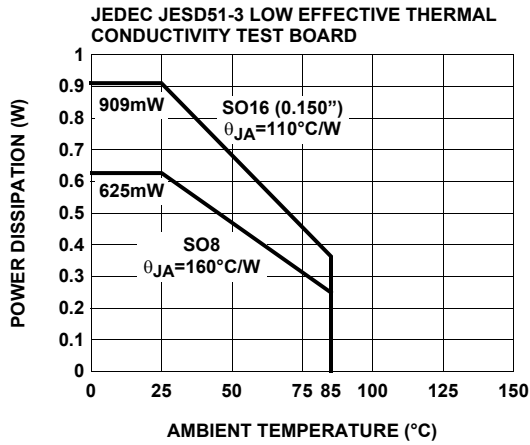

FIGURE 21. PACKAGE POWER DISSIPATION vs AMBIENT TEMPERATURE

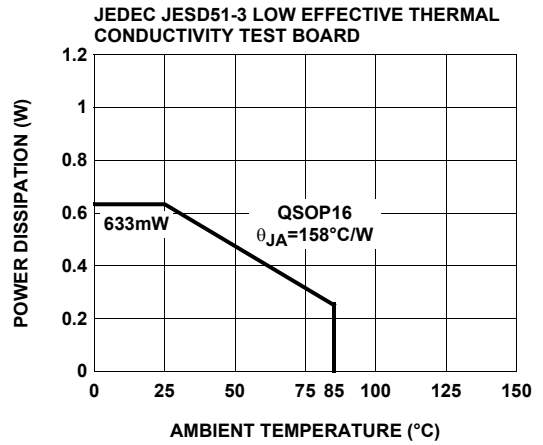

FIGURE 22. PACKAGE POWER DISSIPATION vs AMBIENT TEMPERATURE

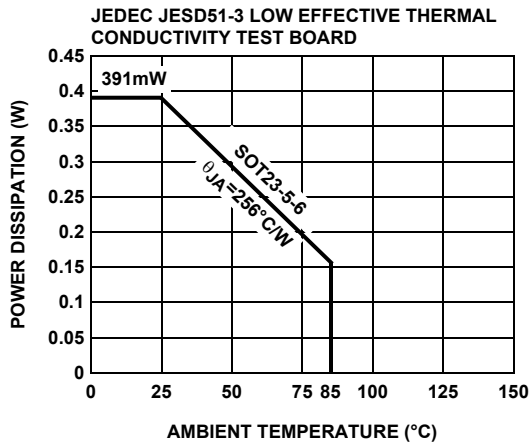

FIGURE 23. PACKAGE POWER DISSIPATION vs AMBIENT TEMPERATURE

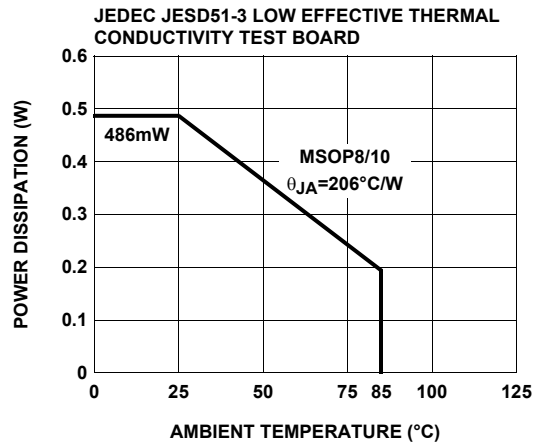
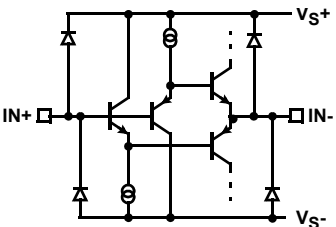
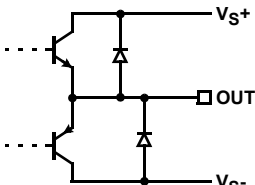
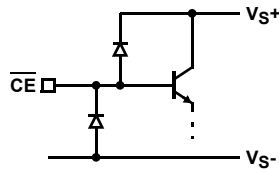

FIGURE 24. PACKAGE POWER DISSIPATION vs AMBIENT TEMPERATURE

Pin Descriptions

EL5160 (8-PIN SO)	EL5160 (6-PIN SOT-23)	EL5161 (5-PIN SOT-23)	PIN NAME	FUNCTION	EQUIVALENT CIRCUIT
1, 5			NC	Not connected	
2	4	4	IN-	Inverting input	 <p style="text-align: center;">Circuit 1</p>
3	3	3	IN+	Non-inverting input	(See circuit 1)
4	2	2	VS-	Negative supply	
6	1	1	OUT	Output	 <p style="text-align: center;">Circuit 2</p>
7	6	5	VS+	Positive supply	
8	5		$\overline{\text{CE}}$	Chip enable	 <p style="text-align: center;">Circuit 3</p>

Applications Information

Product Description

The EL5160, EL5161, EL5260, EL5261, and EL5360 are low power, current-feedback operational amplifiers that offer a wide -3dB bandwidth of 200MHz and a low supply current of 4mA per amplifier. The EL5160, EL5161, EL5260, EL5261, and EL5360 work with supply voltages ranging from a single 5V to 10V and they are also capable of swinging to within 1V of either supply on the output. Because of their current-feedback topology, the EL5160, EL5161, EL5260, EL5261, and EL5360 do not have the normal gain-bandwidth product associated with voltage-feedback operational amplifiers. Instead, their -3dB bandwidth to remain relatively constant as closed-loop gain is increased. This combination of high bandwidth and low power, together with aggressive pricing make the EL5160, EL5161, EL5260, EL5261, and EL5360 ideal choices for many low-power/high-bandwidth applications such as portable, handheld, or battery-powered equipment.

Power Supply Bypassing and Printed Circuit Board Layout

As with any high frequency device, good printed circuit board layout is necessary for optimum performance. Low impedance ground plane construction is essential. Surface mount components are recommended, but if leaded components are used, lead lengths should be as short as possible. The power supply pins must be well bypassed to reduce the risk of oscillation. The combination of a 4.7 μ F tantalum capacitor in parallel with a 0.01 μ F capacitor has been shown to work well when placed at each supply pin.

For good AC performance, parasitic capacitance should be kept to a minimum, especially at the inverting input. (See the Capacitance at the Inverting Input section) Even when ground plane construction is used, it should be removed from the area near the inverting input to minimize any stray capacitance at that node. Carbon or Metal-Film resistors are acceptable with the Metal-Film resistors giving slightly less peaking and bandwidth because of additional series inductance. Use of sockets, particularly for the SO package, should be avoided if possible. Sockets add parasitic inductance and capacitance which will result in additional peaking and overshoot.

Disable/Power-Down

The EL5160 amplifier can be disabled placing its output in a high impedance state. When disabled, the amplifier supply current is reduced to $< 15\mu\text{A}$. The EL5160 is disabled when its $\overline{\text{CE}}$ pin is pulled up to within 1V of the positive supply.

Similarly, the amplifier is enabled by floating or pulling its $\overline{\text{CE}}$ pin to at least 3V below the positive supply. For $\pm 5\text{V}$ supply, this means that an EL5160 amplifier will be enabled when $\overline{\text{CE}}$ is 2V or less, and disabled when $\overline{\text{CE}}$ is above 4V.

Although the logic levels are not standard TTL, this choice of logic voltages allows the EL5160 to be enabled by tying $\overline{\text{CE}}$ to ground, even in 5V single supply applications. The $\overline{\text{CE}}$ pin can be driven from CMOS outputs.

Capacitance at the Inverting Input

Any manufacturer's high-speed voltage- or current-feedback amplifier can be affected by stray capacitance at the inverting input. For inverting gains, this parasitic capacitance has little effect because the inverting input is a virtual ground, but for non-inverting gains, this capacitance (in conjunction with the feedback and gain resistors) creates a pole in the feedback path of the amplifier. This pole, if low enough in frequency, has the same destabilizing effect as a zero in the forward open-loop response. The use of large-value feedback and gain resistors exacerbates the problem by further lowering the pole frequency (increasing the possibility of oscillation.)

The EL5160, EL5161, EL5260, EL5261, and EL5360 have been optimized with a $\text{TBD}\Omega$ feedback resistor. With the high bandwidth of these amplifiers, these resistor values might cause stability problems when combined with parasitic capacitance, thus ground plane is not recommended around the inverting input pin of the amplifier.

Feedback Resistor Values

The EL5160, EL5161, EL5260, EL5261, and EL5360 have been designed and specified at a gain of +2 with R_F approximately 806Ω . This value of feedback resistor gives 200MHz of -3dB bandwidth at $A_V = 2$ with TBDdB of peaking. With $A_V = -2$, an R_F of approximately $\text{TBD}\Omega$ gives 200MHz of bandwidth with 1dB of peaking. Since the EL5160, EL5161, EL5260, EL5261, and EL5360 are current-feedback amplifiers, it is also possible to change the value of R_F to get more bandwidth. As seen in the curve of Frequency Response for Various R_F and R_G , bandwidth and peaking can be easily modified by varying the value of the feedback resistor.

Because the EL5160, EL5161, EL5260, EL5261, and EL5360 are current-feedback amplifiers, their gain-bandwidth product is not a constant for different closed-loop gains. This feature actually allows the EL5160, EL5161, EL5260, EL5261, and EL5360 to maintain about the same -3dB bandwidth. As gain is increased, bandwidth decreases slightly while stability increases. Since the loop stability is improving with higher closed-loop gains, it becomes possible

to reduce the value of R_F below the specified $\text{TBD}\Omega$ and still retain stability, resulting in only a slight loss of bandwidth with increased closed-loop gain.

Supply Voltage Range and Single-Supply Operation

The EL5160, EL5161, EL5260, EL5261, and EL5360 have been designed to operate with supply voltages having a span of greater than 5V and less than 10V. In practical terms, this means that they will operate on dual supplies ranging from $\pm 2.5\text{V}$ to $\pm 5\text{V}$. With single-supply, the EL5160, EL5161, EL5260, EL5261, and EL5360 will operate from 5V to 10V.

As supply voltages continue to decrease, it becomes necessary to provide input and output voltage ranges that can get as close as possible to the supply voltages. The EL5160, EL5161, EL5260, EL5261, and EL5360 have an input range which extends to within 2V of either supply. So, for example, on +5V supplies, the EL5160, EL5161, EL5260, EL5261, and EL5360 have an input range which spans $\pm 3\text{V}$. The output range of the EL5160, EL5161, EL5260, EL5261, and EL5360 is also quite large, extending to within 1V of the supply rail. On a $\pm 5\text{V}$ supply, the output is therefore capable of swinging from -4V to +4V. Single-supply output range is larger because of the increased negative swing due to the external pull-down resistor to ground.

Video Performance

For good video performance, an amplifier is required to maintain the same output impedance and the same frequency response as DC levels are changed at the output. This is especially difficult when driving a standard video load of 150Ω , because of the change in output current with DC level. Previously, good differential gain could only be achieved by running high idle currents through the output transistors (to reduce variations in output impedance.) These currents were typically comparable to the entire 1mA supply current of each EL5160, EL5161, EL5260, EL5261, and EL5360 amplifier. Special circuitry has been incorporated in the EL5160, EL5161, EL5260, EL5261, and EL5360 to reduce the variation of output impedance with current output. This results in dG and dP specifications of 0.1% and 0.1° , while driving 150Ω at a gain of 2.

Video performance has also been measured with a 500Ω load at a gain of +1. Under these conditions, the EL5160 has dG and dP specifications of 0.1% and 0.1° .

Output Drive Capability

In spite of their low 1mA of supply current, the EL5160, EL5161, EL5260, EL5261, and EL5360 are capable of providing a minimum of $\pm 50\text{mA}$ of output current. With a minimum of $\pm 50\text{mA}$ of output drive, the EL5160 is capable of driving 50Ω loads to both rails, making it an excellent choice for driving isolation transformers in telecommunications applications.

Driving Cables and Capacitive Loads

When used as a cable driver, double termination is always recommended for reflection-free performance. For those applications, the back-termination series resistor will decouple the EL5160, EL5161, EL5260, EL5261, and EL5360 from the cable and allow extensive capacitive drive. However, other applications may have high capacitive loads without a back-termination resistor. In these applications, a small series resistor (usually between 5Ω and 50Ω) can be placed in series with the output to eliminate most peaking. The gain resistor (R_G) can then be chosen to make up for any gain loss which may be created by this additional resistor at the output. In many cases it is also possible to simply increase the value of the feedback resistor (R_F) to reduce the peaking.

Current Limiting

The EL5160, EL5161, EL5260, EL5261, and EL5360 have no internal current-limiting circuitry. If the output is shorted, it is possible to exceed the Absolute Maximum Rating for output current or power dissipation, potentially resulting in the destruction of the device.

Power Dissipation

With the high output drive capability of the EL5160, EL5161, EL5260, EL5261, and EL5360, it is possible to exceed the 125°C Absolute Maximum junction temperature under certain very high load current conditions. Generally speaking when R_L falls below about 25Ω, it is important to calculate the maximum junction temperature (T_{JMAX}) for the application to determine if power supply voltages, load conditions, or package type need to be modified for the EL5160, EL5161, EL5260, EL5261, and EL5360 to remain in the safe operating area. These parameters are calculated as follows:

$$T_{JMAX} = T_{MAX} + (\theta_{JA} \times n \times PD_{MAX})$$

where:

- T_{MAX} = Maximum ambient temperature
- θ_{JA} = Thermal resistance of the package
- n = Number of amplifiers in the package
- PD_{MAX} = Maximum power dissipation of each amplifier in the package

PD_{MAX} for each amplifier can be calculated as follows:

$$PD_{MAX} = (2 \times V_S \times I_{SMAX}) + \left[(V_S - V_{OUTMAX}) \times \frac{V_{OUTMAX}}{R_L} \right]$$

where:

- V_S = Supply voltage
- I_{SMAX} = Maximum supply current of 0.75mA
- V_{OUTMAX} = Maximum output voltage (required)
- R_L = Load resistance

Typical Application Circuits

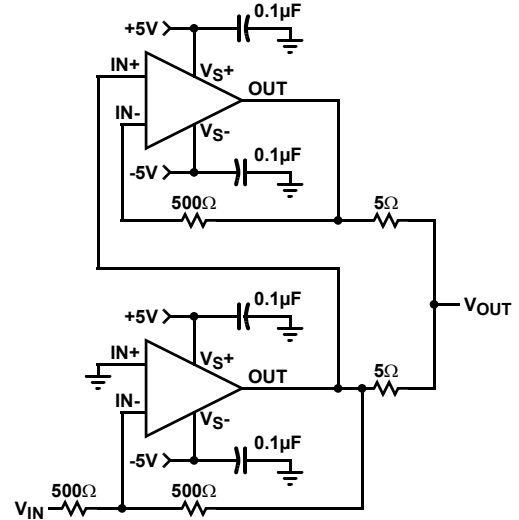

FIGURE 25. INVERTING 200mA OUTPUT CURRENT DISTRIBUTION AMPLIFIER

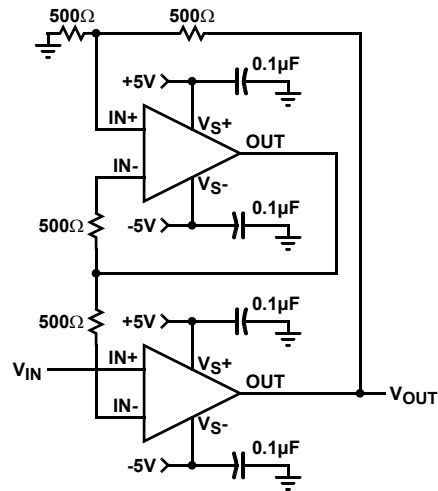

FIGURE 26. FAST-SETTLING PRECISION AMPLIFIER

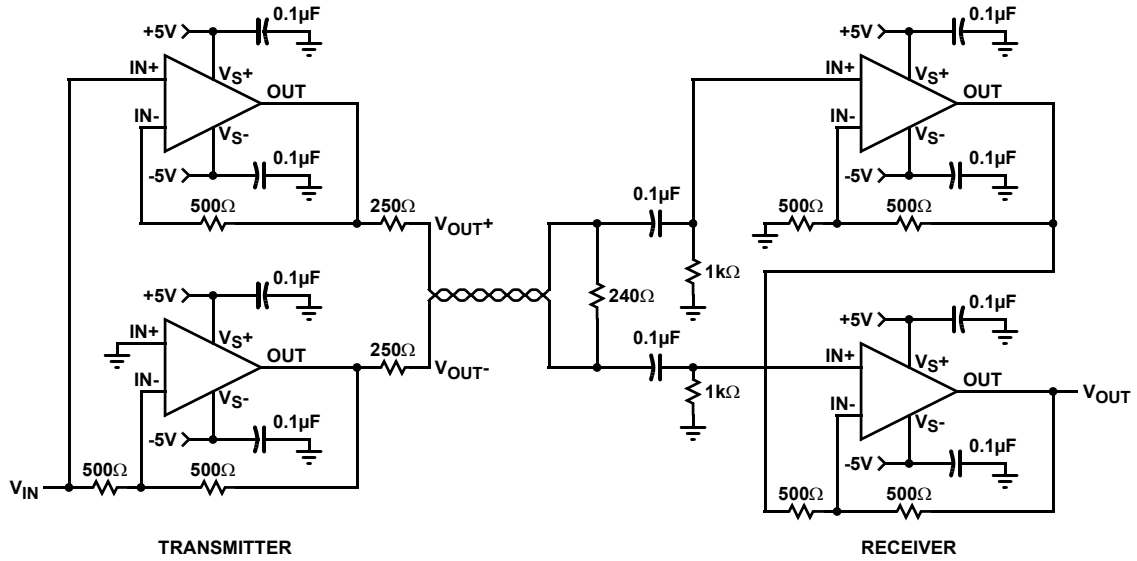

FIGURE 27. DIFFERENTIAL LINE DRIVER/RECEIVER

All Intersil U.S. products are manufactured, assembled and tested utilizing ISO9000 quality systems.
 Intersil Corporation's quality certifications can be viewed at www.intersil.com/design/quality

Intersil products are sold by description only. Intersil Corporation reserves the right to make changes in circuit design, software and/or specifications at any time without notice. Accordingly, the reader is cautioned to verify that data sheets are current before placing orders. Information furnished by Intersil is believed to be accurate and reliable. However, no responsibility is assumed by Intersil or its subsidiaries for its use; nor for any infringements of patents or other rights of third parties which may result from its use. No license is granted by implication or otherwise under any patent or patent rights of Intersil or its subsidiaries.

For information regarding Intersil Corporation and its products, see www.intersil.com



LittleDiode supplies new, hard to find or obsolete electronic components and semiconductors all over the world.

With over two million different components listed you are sure to find the part you need.

Feel free to visit us today at our online store:

LittleDiode.com

Looking forward to providing you with the best possible service.