

FEATURES

- programmable parameters
 - gain
 - low pass filter
 - high pass filter
 - AGC threshold
 - release time
 - MPO
 - receiver bias voltage
- on-chip voltage regulator
- typical gain 60 dB
- voltage drive output stage
- telecoil preamp

STANDARD PACKAGING

- Chip (136 x 110 mils)
Au Bump

CIRCUIT DESCRIPTION

The GP520A is a programmable analog signal path IC designed for use in hearing instruments. The GP520A's programmable parameters are adjusted by external programming currents, such as generated by the GP521. The GP520A provides a $2.5 \mu\text{A}$ reference current for use by the GP521. Sixteen settings are possible in the GP521, allowing the Programmable Current Sink (PCS) to sink between 0 and $1.875 \times I_{\text{REF}}$.

The GP520A is composed of five functional blocks. The input preamp, a filter block, the AGC block, MPO clipper and the output stage.

Principle features of the preamp are the input impedance $100 \text{ k}\Omega$ and a gain of 14 dB.

The programmable filter block is composed of a low pass and high pass filter which generates a range of high and low pass corner frequencies. Although the control current to this block varies linearly, linear to logarithmic conversion is performed internally in order to adjust the corner frequencies logarithmically. Both filters feature a 12 dB/octave rolloff and unity gain.

The filters are followed by an AGC block. Up to 35 dB of adjustable gain is provided as well as programmable threshold and release time. The attack time of the AGC block remains fixed and is independent of the release time. The output current is driven into the preamp of the clipper, thus, the AGC converts a voltage input into a current output and is therefore, a transconductance block.

The next stage is an electronic MPO control peak "clipper" providing electronic clipping of the signal and setting of the maximum output level. The clipper output is also a transconductance block and drives a $40 \text{ k}\Omega$ resistor ($R_{\text{OUT } 8}$) tied to the supply.

The input of the final stage is an inverting operational amplifier. A feedback resistance of $240 \text{ k}\Omega$ is provided internally and this final stage is thus configured as a voltage drive output stage. The DC bias current through the receiver is also programmable.

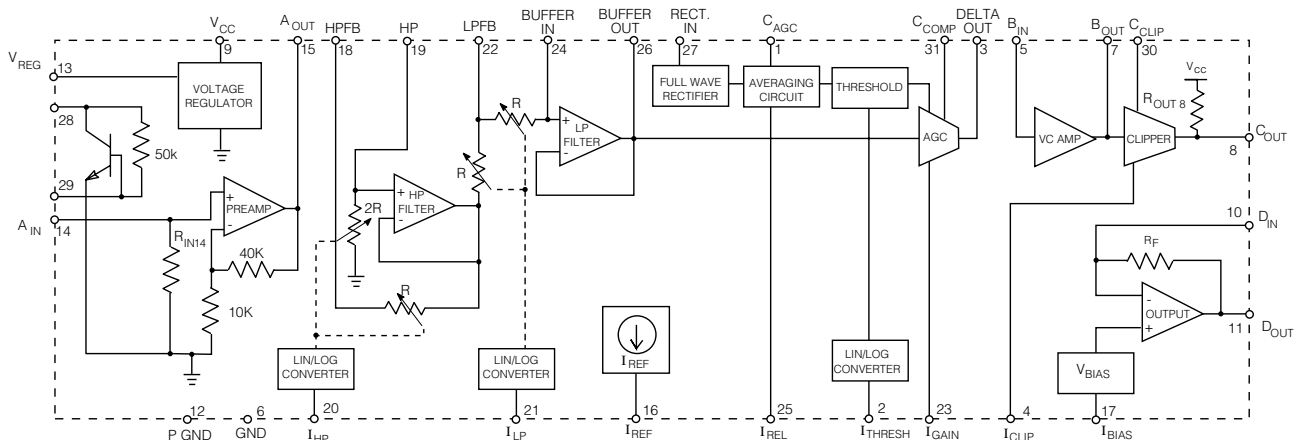

All resistors in ohms, all capacitors in farads unless otherwise stated.

FUNCTIONAL BLOCK DIAGRAM

CHIP PAD DIAGRAM

ABSOLUTE MAXIMUM RATINGS

PARAMETER	VALUE / UNITS
Supply Voltage	5 V
Pad 3, 8, 10, 11, 13, 17	-0.1 V to $V_{CC} + 0.1$ V
Pad 1, 15, 16, 18, 19, 22, 24, 26	-0.1 V to $V_{REG} + 0.1$ V
Pad 4, 5, 7, 14, 20, 21, 23, 25, 27	-0.1 V to 0.7 V
Pad 2	$V_{REG} - 0.7$ V to $V_{REG} + 0.1$ V

CAUTION
CLASS 1 ESD SENSITIVITY



ELECTRICAL CHARACTERISTICS

All parameters are measured at $T_A = 25^\circ\text{C}$

All gains are calculated from equation $G = 20 \text{ LOG} (\Delta\text{OUT}/\Delta\text{IN})$ where ΔOUT and ΔIN are appropriate voltage or current increases.

All resistances are calculated according to equation $R = (V_P - V_Q) / I_{\text{COND}}$ where V_P is voltage on the pad loaded with I_{COND} current.

V_Q - quiescent (unbias) voltage measured on the pad, (nothing connected to the pin).

V_P is the actual voltage measured on the pad at given condition (where P is pad number).

For all graphs I_{REF} is measured with 0.5V biased voltage on pin 16.

GENERAL

PARAMETER	SYMBOL	CONDITIONS	MIN	TYP	MAX	UNITS
Amplifier Current	I_{AMP}	All PCS set to 15	-	600	-	μA
Minimum Voltage	V_{CC}		1.1	-	-	V

REGULATOR TESTS

Regulator Voltage (Pad 13)	V_{REG}		-	0.98	-	V
Short Circuit Current (Pad 13)	I_{SC}	S1 — closed	-	2.0	-	mA

CURRENT REFERENCE

Current Reference (Pad 16)	I_{R}		-	2.5	-	μA
----------------------------	----------------	--	---	-----	---	---------------

PREAMPLIFIER

Quiescent Voltage on Pad 14	V_{Q14}		600	-	-	mV
Quiescent Voltage on Pad 15	V_{Q15}		600	-	-	mV
Input Resistance (Pad 14)	$R_{\text{IN } 14}$	$I_{14} = 0.3\mu\text{A}$ (S2 closed)(Note 1)	-	100	-	$\text{k}\Omega$
Output Swing High (Pad 15)	V_{OH}	$V_{14} = 0.8\text{V}$ (S3 closed)(Note 1)	200	-	-	mV
Output Swing Low (Pad 15)	V_{OL}	$V_1 = 0.4\text{V}$ (S3 closed)	-200	-	-	mV
Max Source Current (Pad 15)	I_{SOURCE}	$V_{14} = 0.8\text{V}$ (S3, S4 closed) $V_{15} = V_{\text{Q15}} + 100\text{mV}$	30	-	-	μA
Max Sinking Current (Pad 15)	I_{SINK}	$V_{14} = 0.4\text{V}$ (S3, S4 closed) $V_{15} = V_{\text{Q15}} - 100\text{mV}$	30	-	-	μA
Preamplifier Voltage Gain	GAIN	$V_{14} = V_{\text{Q14}} \pm 10\text{mV}$ (S3 closed)	-	14	-	dB

NOTE: 1. $V_{\text{OL}} = V_{\text{OH}} = V_{\text{P15}} - V_{\text{Q15}}$

All switches remain OPEN unless otherwise stated in CONDITIONS column.

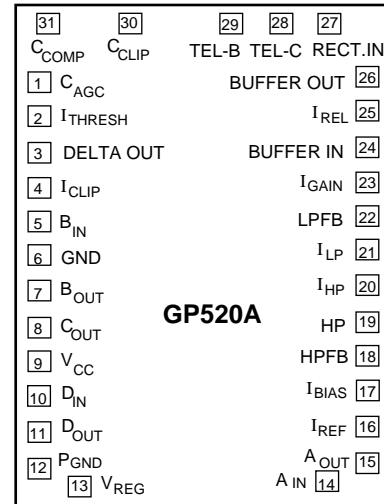

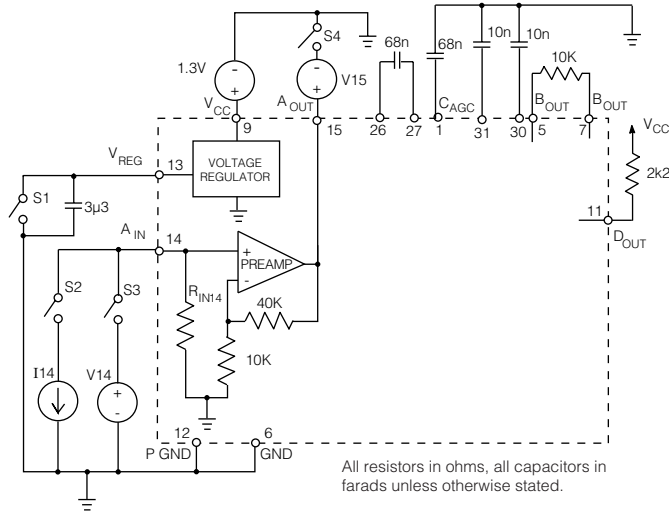

Fig. 1 Preamp and Regulator Test Circuit

HIGH PASS FILTER

PARAMETER	SYMBOL	CONDITIONS	MIN	TYP	MAX	UNITS
Quiescent Voltage on Pad 18	V_{Q18}		-	650	-	mV
Quiescent Voltage on Pad 19	V_{Q19}		-	650	-	mV
Quiescent Voltage on Pad 20	V_{Q20}		-	550	-	mV
Maximum DC Current from Pad 19	$I_{HP\ MAX}$	$I_{HP} = 0\mu A$ (S3 closed)	-	2	-	μA
Minimum DC Current from Pad 19	$I_{HP\ MIN}$	$I_{HP} = 1.875 \times I_R$ (S3 closed)	-	200	-	nA
Buffer Gain	GAIN	$V_{19} = V_{Q19} \pm 100mV$ (S2 closed)	-	0	-	dB
Input Resistance Pad 20	R_{IN20}	$I_{HP} = I_R$	-	13	-	$k\Omega$

All switches remain OPEN unless otherwise stated in CONDITIONS column.

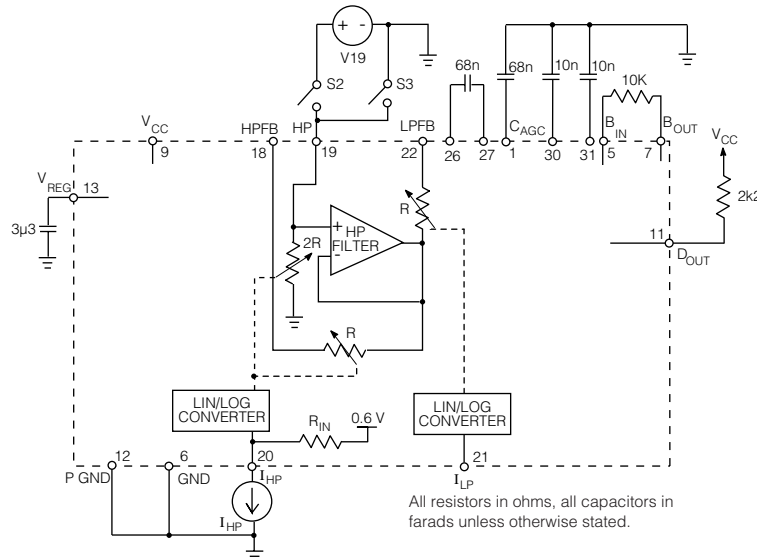

Fig. 2 High Pass Filter DC Test Circuit

LOW PASS FILTER

PARAMETER	SYMBOL	CONDITIONS	MIN	TYP	MAX	UNITS
Quiescent Voltage on Pad 21	V_{Q21}		-	550	-	mV
Quiescent Voltage on Pad 22	V_{Q22}		-	650	-	mV
Quiescent Voltage on Pad 24	V_{Q24}		-	650	-	mV
Quiescent Voltage on Pad 26	V_{Q26}		-	650	-	mV
Maximum DC Current from Pad 22	$I_{LP\ MAX}$	$I_{LP} = 0\mu A$ (S1 closed)	-	2.0	-	μA
Minimum DC Current from Pad 22	$I_{LP\ MIN}$	$I_{LP} = 1.875 \times I_R$ (S1 closed)	-	0.7	-	μA
Output Swing High (Pad 26)	V_{OH}	$V_{24} = V_{Q24} + 100mV$ (S2 closed)(Note 1)	-	100	-	mV
Output Swing Low (Pad 26)	V_{OL}	$V_{24} = V_{Q24} - 100mV$ (S2 closed)(Note 1)	-	-100	-	mV
Max Sinking Current from Pad 26	I_{SINK}	$V_{24} = 0.4V$; $V_{26} = V_{Q26} - 100mV$ (S2, S3 closed)	30	-	-	μA
Max Sourcing Current to Pad 26	I_{SOURCE}	$V_{24} = 0.8V$; $V_{26} = V_{Q26} \pm 100mV$ (S2, S3 closed)	-30	-	-	μA
Buffer Gain	GAIN	$V_{26} = V_{Q26} \pm 100mV$	-	0	-	dB
Input Resistance (Pad 21)	R_{IN21}	$I_{LP} = I_R$	-	13	-	$k\Omega$

NOTE: 1. $V_{OH} = V_{OL} = V_{P26} - V_{Q26}$

All switches remain OPEN unless otherwise stated in CONDITIONS column.

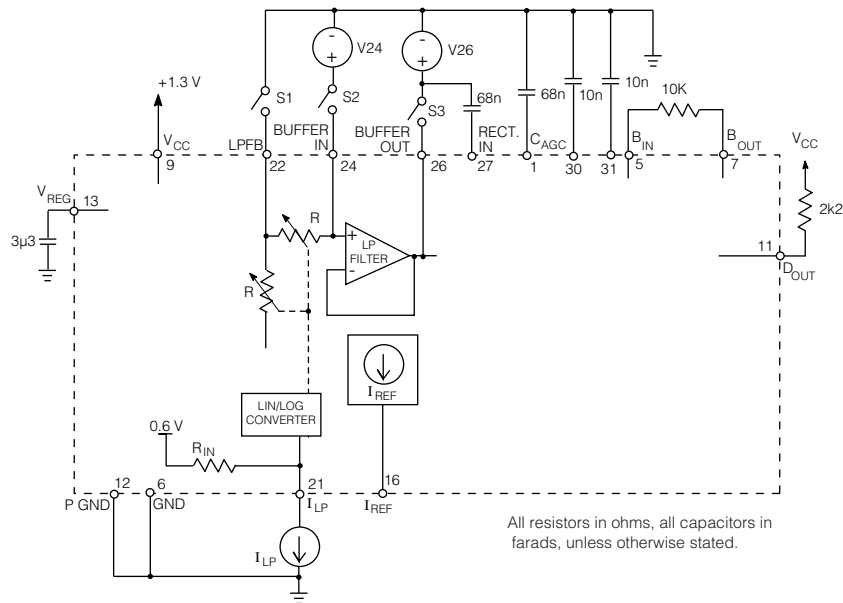

Fig. 3 Low Pass Filter DC Test Circuit

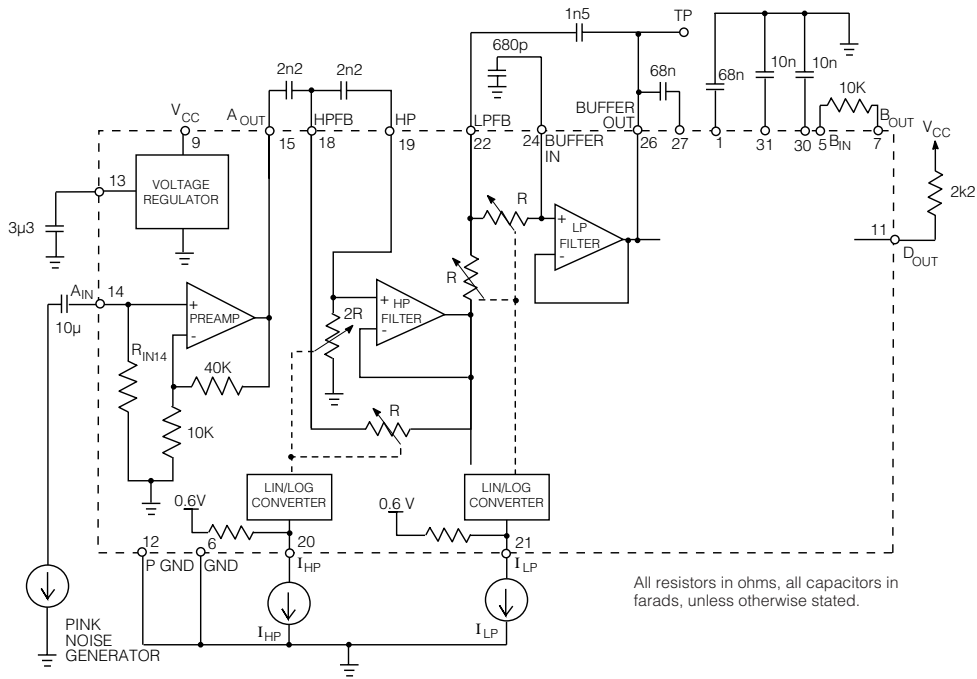

Fig. 4 AC Test Circuit for High & Low Pass Filters

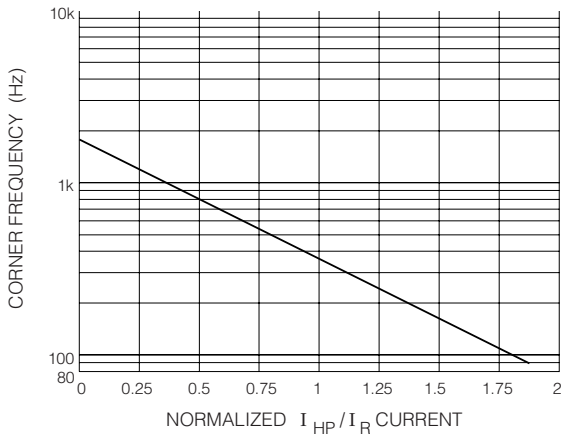

Fig. 5 High Pass Filter Corner Frequency vs I_{HP} Current (Note 1) (Fig.4 Test Circuit)

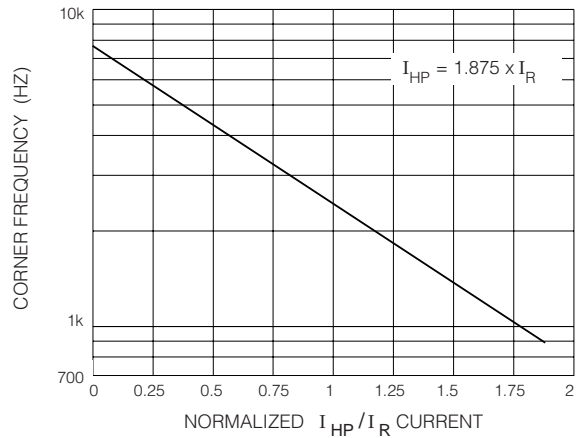

Fig. 6 Low Pass Filter Corner Frequency vs I_{LP} Current (Note 1) (Fig.4 Test Circuit)

NOTES: 1. Corner frequency calculated in reference to signal at 3 kHz

AGC CONTROL STAGE

PARAMETER	SYMBOL	CONDITIONS	MIN	TYP	MAX	UNITS
Quiescent Voltage on Pad 2	V_{Q2}	$I_{THRESH} = I_R$	-	400	-	mV
Quiescent Voltage on Pad 3	V_{Q3}	$I_{GAIN} = I_R \times 1.875$	-	700	-	mV
Quiescent Voltage on Pad 23	V_{Q23}		-	500	-	mV
Quiescent Voltage on Pad 25	V_{Q25}		-	500	-	mV
Quiescent Voltage on Pad 27	V_{Q27}		-	600	-	mV
Release Current Max (Pad 1)	$I_{REL\ MAX}$	$I_{REL} = 0$ (S1 closed)	-	300	-	nA
Release Current Min (Pad 1)	$I_{REL\ MIN}$	$I_{REL} = 1.875 \times I_R$ (S1 closed)	-	30	-	nA
Input Resistance (Pad 25)	R_{IN25}	$I_{REL} = I_R$	-	17	-	k Ω
Input Resistance (Pad 27)	R_{IN27}	$I_{27} = \pm I_R$	-	4	-	k Ω
Max Transconductance (Pad 26 to V_O)	G_{MAX}	$I_{GAIN} = I_R \times 2 \times 1.875$ $V_{P26} = 30$ mVpp $I_{THRESH} = 1.875 \times I_R$ (Note 1)	-	160	-	$\mu A/V$
Gain Range (Pad 26 to V_O)	$GAIN_{RANGE}$	$I_{THRESH} = 1.875 \times I_R$ (Note 2) $V_{26} = 25$ mVpp	-	33	-	dB
Output Limiting Level (Pad 3)	OUT_{LIM}	$I_{THRESH} = I_R$, $I_{GAIN} = 2 \times 1.875 \times I_R$ $V_{26} = 100$ mVpp (Note 3)	-	0.7	-	$\mu ARMS$
Limiting Level Range	LIM_{RANGE}	$I_{GAIN} = I_R \times 2 \times 1.875$ (Note 4) $V_{26} = 100$ mVpp	-	13	-	dB
AGC Compression Ratio	CMP_{RAT}	$I_{THRESH} = I_R$ $I_{GAIN} = 2 \times 1.875 \times I_R$ (Note 5)	-	5	-	

Unless otherwise stated in CONDITIONS column all switches remain OPEN, all current sources are 0 μA

NOTES:

- $G_{MAX} = V_O / (V_{26} \times 1M)$
- $GAIN_{RANGE} = 20 \text{ LOG } (V_O [I_{GAIN} = 2 \times 1.875 \times I_R] / V_O [I_{GAIN} = 0])$
- $OUT_{LIM} = V_O / 1M$
- $LIM_{RANGE} = 20 \text{ LOG } (V_O [I_{THRESH} = 1.875 \times I_R] / V_O [I_{THRESH} = 0])$
- $CMP_{RAT} = \frac{10}{20 \text{ LOG } (V_O [V_{26} = 5.62 \text{ mVRMS}] / V_O [V_{26} = 17.8 \text{ mVRMS}]) - 45 \text{ dBV} - 35 \text{ dBV}}$

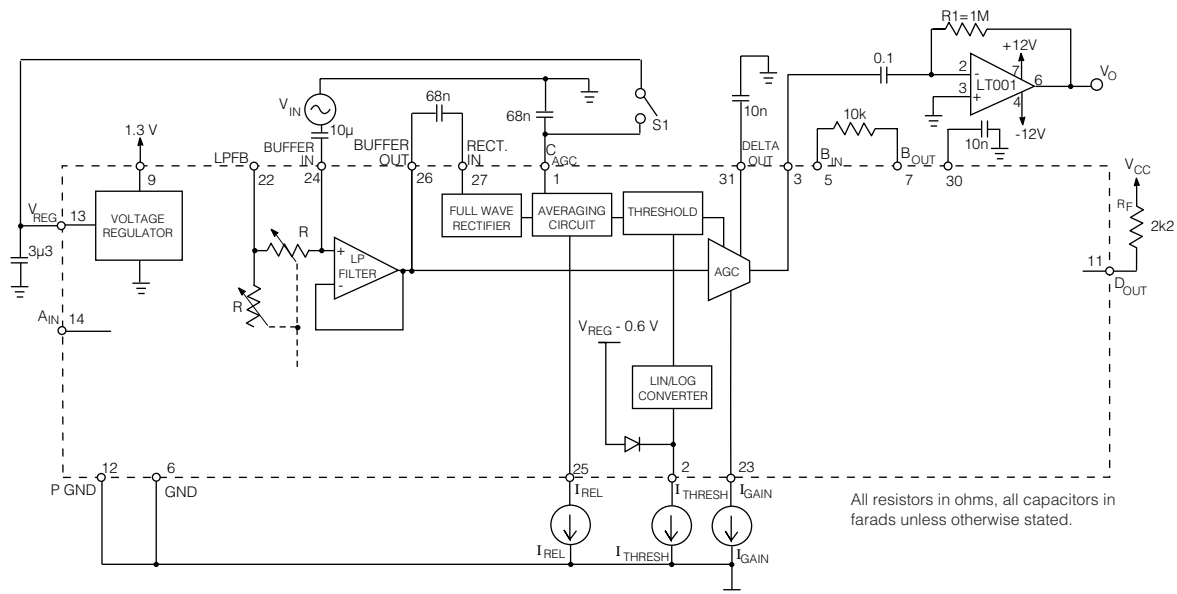

Fig. 7 AGC Control Stage Test Circuit

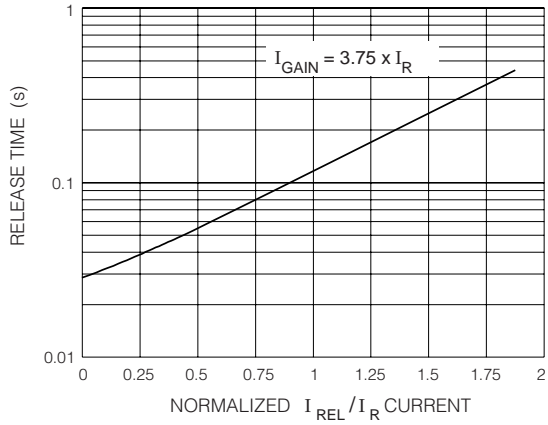

Fig. 8 Release Time vs I_{REL} (Fig.7 Test Circuit)

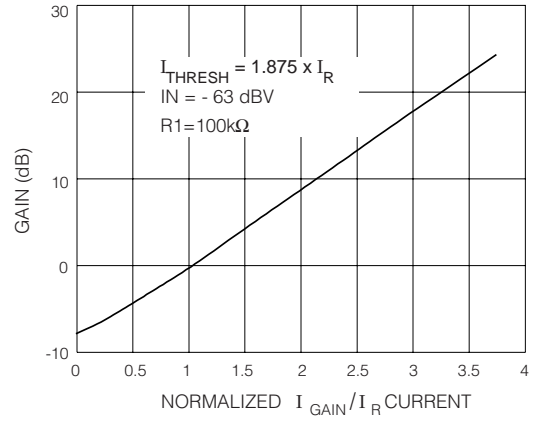

Fig. 9 AGC Gain vs I_{GAIN} (Fig.7 Test Circuit)

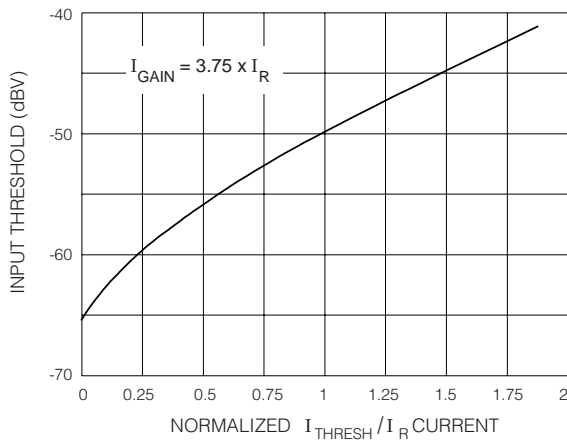

Fig. 10 Threshold Level vs I_{THRESH} (Fig.7 Test Circuit)

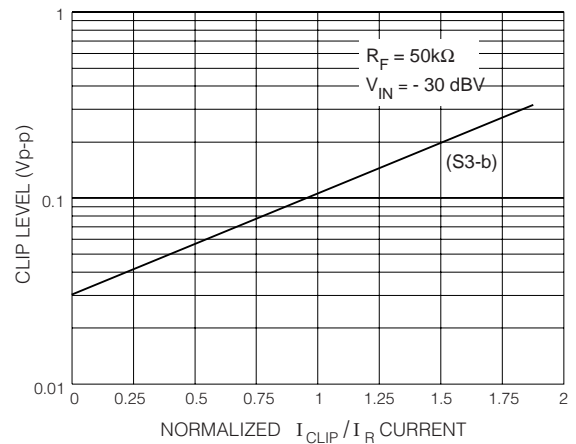

Fig. 11 Output Swing vs I_{CLIP} (Fig.13 Test Circuit) (note 1)

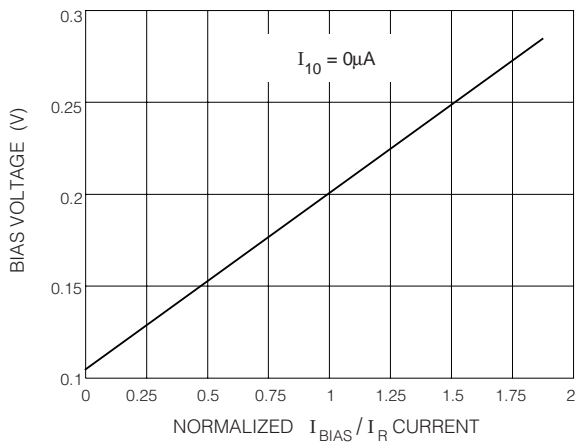

Fig. 12 Receiver Bias Voltage vs I_{BIAS} (Fig. 14 Test Circuit)

NOTE: 1. Switch S2 - open, S4 - closed.

CLIPPER STAGE

PARAMETER	SYMBOL	CONDITIONS	MIN	TYP	MAX	UNITS
Quiescent Voltage on Pad 5	V_{Q5}	(S1 closed)	-	550	-	mV
Input Bias Current (Pad 5)	I_{BIAS}	$R_{F1}=1M$ $R_{F2}=0\Omega$ (Note 1)	-	0	-	nA
Quiescent Voltage on Pad 4	V_{Q4}		-	500	-	mV
Quiescent Voltage on Pad 8	V_{Q8}		-	1.2	-	V
Output Swing High 1 (Pad 8)	V_{OH1}	$I_{IN} = +1\mu A$ $I_{CLIP} = 0\mu A$ (Note 2)	5	-	-	mV
Output Swing Low 1 (Pad 8)	V_{OL1}	$I_{IN} = -1\mu A$ $I_{CLIP} = 0\mu A$ (Note 2)	-5	-	-	mV
Output Clip Symmetry 1	V_{SYM1}	(Note 3)	-	1	-	
Output Swing High 2 (Pad 8)	V_{OH2}	$I_{IN} = 5\mu A$ $I_{CLIP} = 1.875 \times I_R$ (Note 2)	-	50	-	mV
Output Swing Low 2 (Pad 8)	V_{OL2}	$I_{IN} = -5\mu A$ $I_{CLIP} = 1.875 \times I_R$ (Note 2)	-	-50	-	mV
Output Clip Symmetry 2	V_{SYM2}	(Note 3)	-	1	-	
Output Resistance (Pad 8)	R_{OUT8}	$I_{P8} = 10\mu A$ (S2 closed)	-	40	-	k Ω
Clipper Voltage Gain	GAIN	$V_{IN} = 50mV_{pp}$ (S3-b) $I_{CLIP} = 1.875 \times I_R$ (Note 4)	-	12	-	dB

All switches remain as shown in the Test Circuit unless otherwise stated in CONDITIONS column.

NOTES: 1. $I_{BIAS} = (V_7 \Big|_{R_F=1M\Omega} - V_7 \Big|_{R_F=0\Omega}) / 1M\Omega$

3. $V_{SYM} = (2V_{OH} / (V_{OH} - V_{OL}))$

2. $V_{OL} = V_{OH} = V_{Q8} - V_8$

4. $GAIN = 20 \log (V_8 / V_7)$

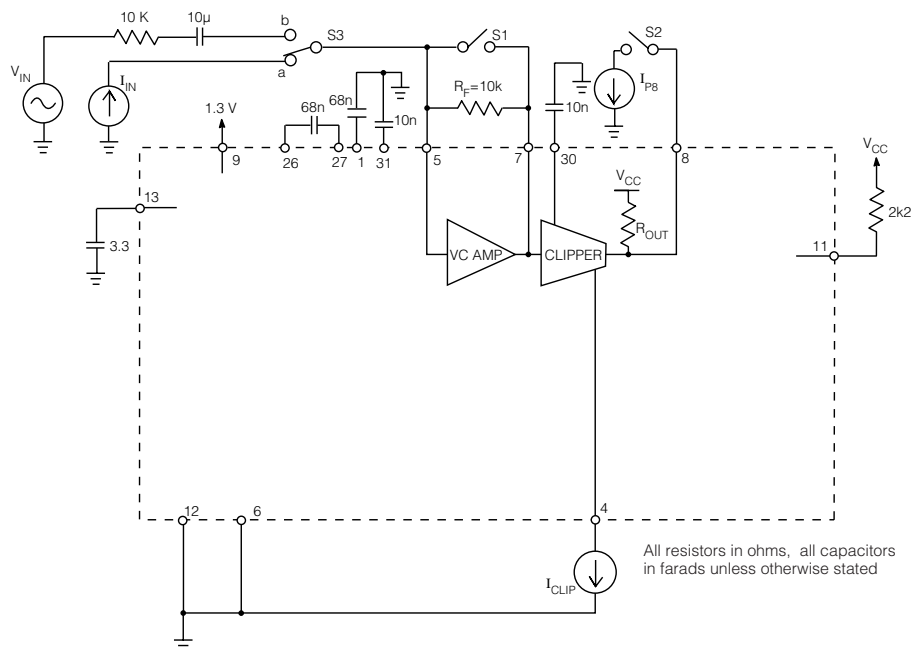

Fig. 13 Clipper Test Circuit

OUTPUT STAGE

PARAMETER	SYMBOL	CONDITIONS	MIN	TYP	MAX	UNITS
Quiescent Voltage on Pad 17	V_{17}		-	1.2	-	V
Min Receiver Bias Voltage	$V_{REC\ MIN}$	$I_{BIAS} = 0\mu A$ (Note 1)	-	100	-	mV
Max Receiver Bias Voltage	$V_{REC\ MAX}$	$I_{BIAS} = I_R \times 1.875$ (Note 1)	-	300	-	mV
Input Resistance Pad 17	R_{IN17}	$I_{BIAS} = I_R$	-	40	-	k Ω
Internal Feedback Resistor	R_F	$I_{10} = I_R$	-	240	-	k Ω
Max Sinking Current (Pad 11)	I_{SINK}	(S1 closed)	-	10	-	mA

NOTE: 1. $V_{REC} = V_{CC} - V_{11}$

All switches remain as shown in the Test Circuit otherwise stated in the CONDITION column.

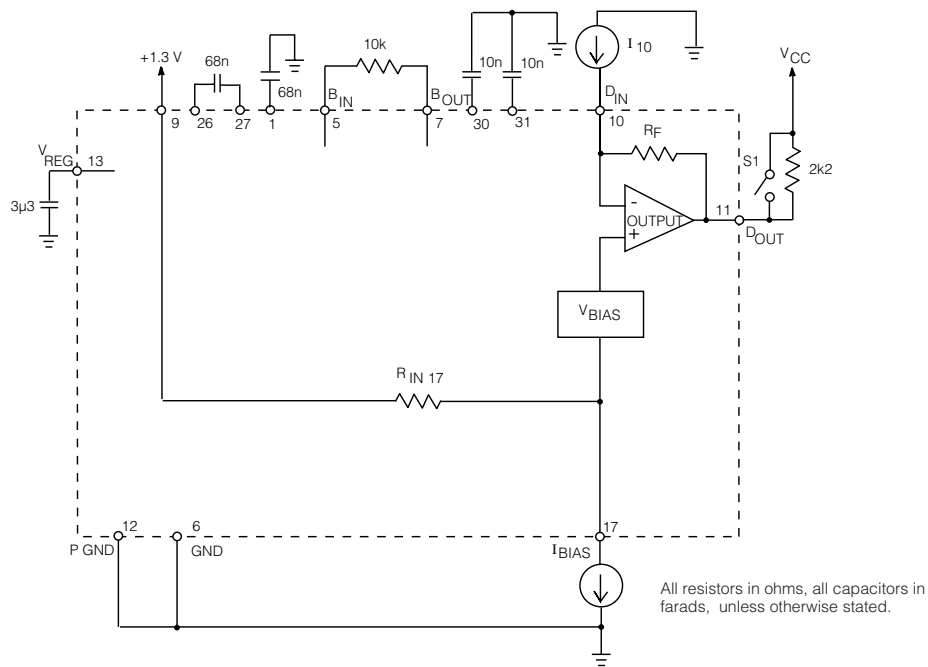
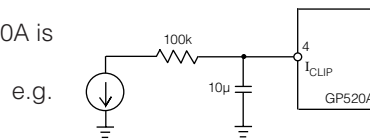

Fig. 14 Output Stage Test Circuit

COMMENTS:

- Pin 23 and Pin 4 represent virtual ground inputs.
- If the length of the wires between the current sources and the GP520A is extensive, it may be necessary to connect an RC filter close to the appropriate GP520A pin for noise immunity.



All resistors in ohms, all capacitors in farads, unless otherwise stated.

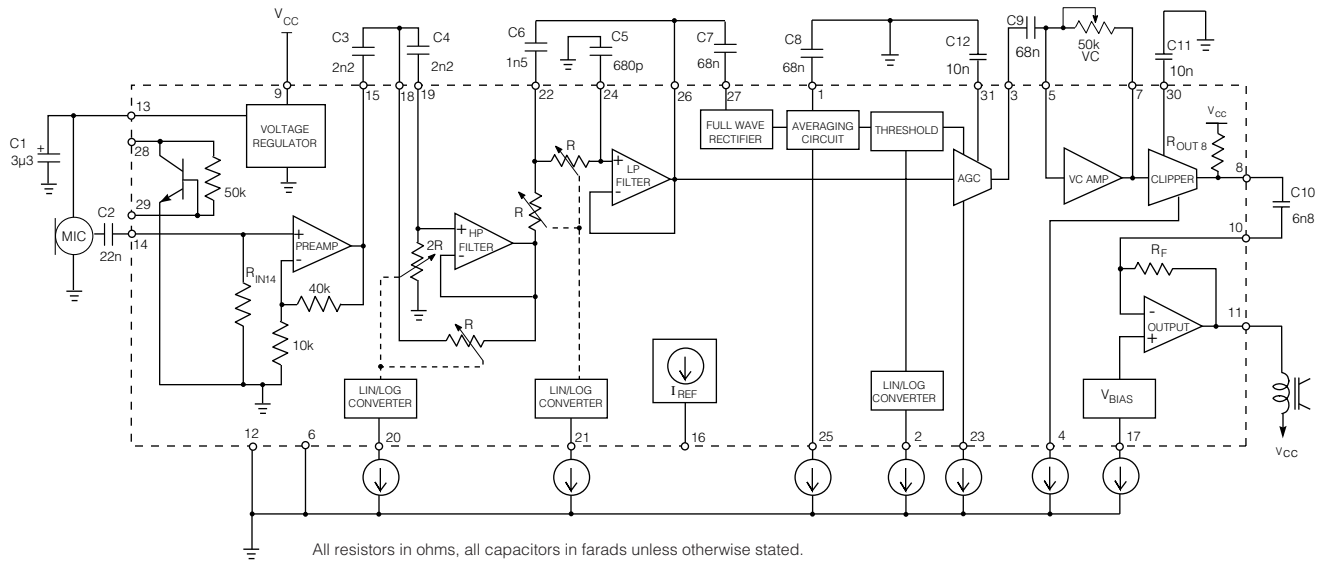

Fig. 15 Typical Application Circuit

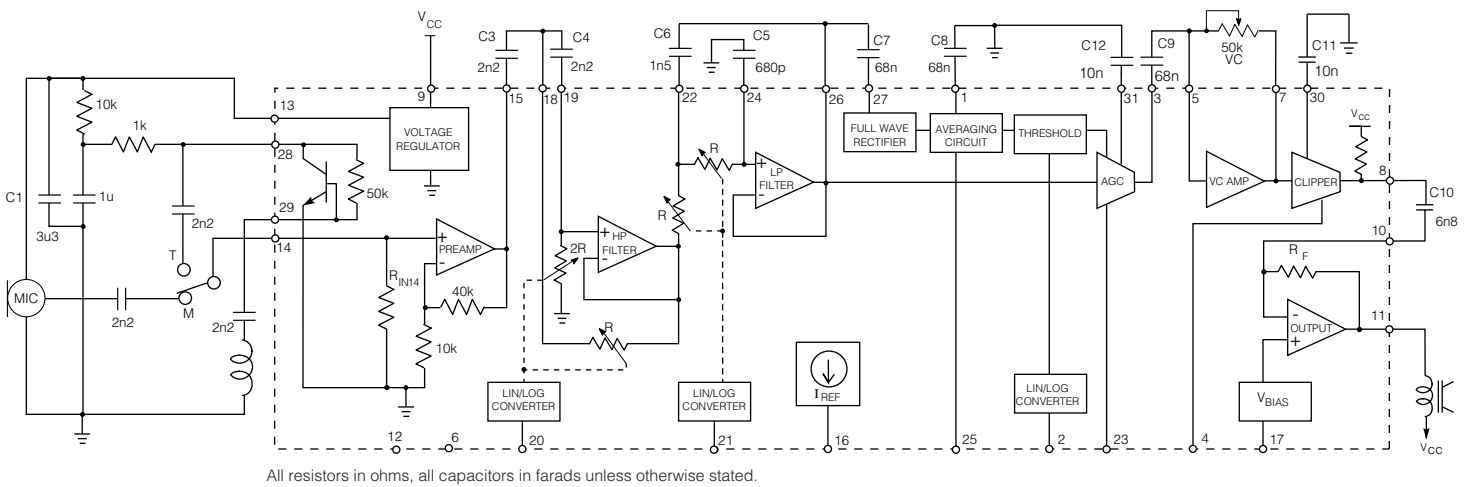

Fig. 16 Typical Telecoil Application Circuit

DOCUMENT IDENTIFICATION: DATA SHEET

The product is in production. Gennum reserves the right to make changes at any time to improve reliability, function or design, in order to provide the best product possible.

REVISION NOTES:

Updated to Data sheet



LittleDiode supplies new, hard to find or obsolete electronic components and semiconductors all over the world.

With over two million different components listed you are sure to find the part you need.

Feel free to visit us today at our online store:

LittleDiode.com

Looking forward to providing you with the best possible service.