

HA13491S

Three-Phase Motor Driver With Speed Discriminator

Description

The HA13491S is a 3-phase brushless motor drive IC designed for use as a 5- and 12-volt HDD spindle motor driver. It has the following functions and features.

- CLK and FG dividers
- Standby circuit
- Current control circuit
- OTSD temperature protection circuit

Functions

- 1.5 A/phase 3-phase drive circuit
- Digital speed control circuit
- Digital ready circuit
- FG amp
- Short brake circuit

Features

- Soft switching driver circuit
- No need for output snubber circuits
- Low saturation voltage
- Wide operating voltage range

Ordering Information

Type No.	Package
HA13491S	MP-26DT

HA13491S

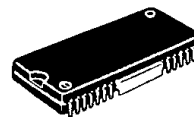

(MP-26DT)

Pin Arrangement

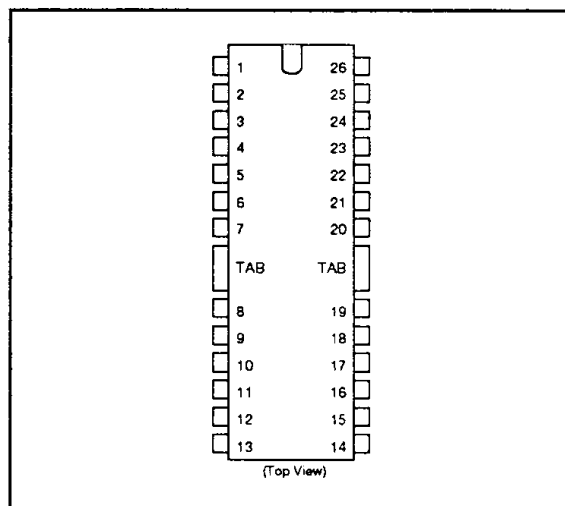

Pin No.	Function	Pin No.	Function
1	Charge pump output	16	Status output
2	W phase output	17	OSC input
3	W + input	18	OSC output
4	W - input	19	D2 select
5	V + input	20	GND
6	V - input	21	AGC filter
7	GND	22	FG + input
8	V phase output	23	FG - input
9	U + input	24	FG motor
10	U - input	25	D1 select
11	U phase output	26	Charge pump bias
12	Current detection		
13	CE		
14	VCC		
15	Control amp phase compensation		



HA13491S

Block Diagram

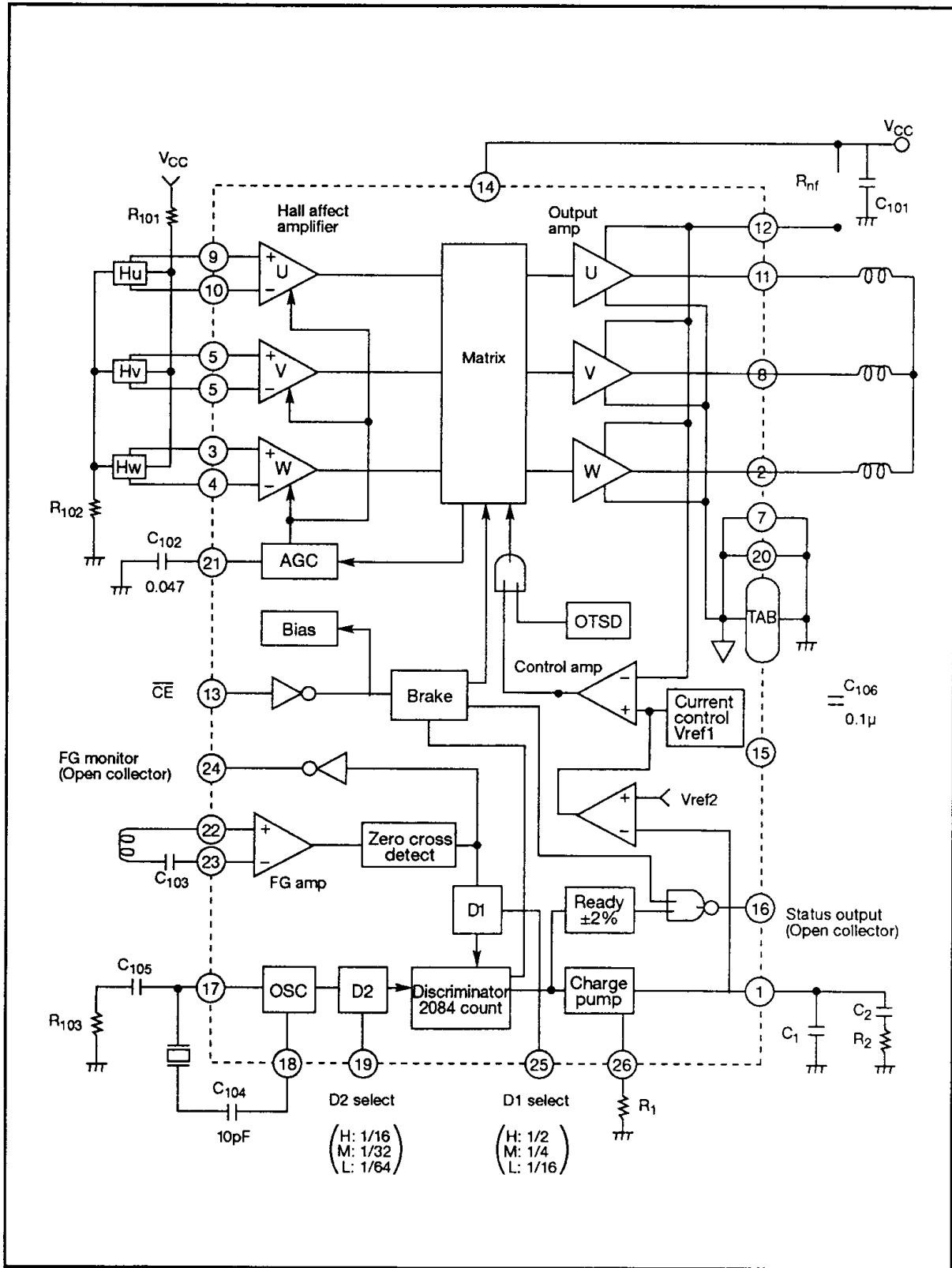

External Parts

Part No.	Recommended Value	Purpose	Notes
R ₁	≤ 10 kΩ	Integration constant	1
R ₂	—	Integration constant	1
R ₁₀₁ , R ₁₀₂	—	Hall effect bias	2
R ₁₀₃	470 Ω	Oscillator stabilization	3
R _{nf}	≥ 0.27 Ω	Current detection	4
C ₁	—	Integration constant	1
C ₂	—	Integration constant	1
C ₁₀₁	≥ 0.1 μF	Power supply bypass	5
C ₁₀₂	0.047 μF	AGC filter	
C ₁₀₃	—	FG coupling	6
C ₁₀₄	10 pF	Oscillator coupling	
C ₁₀₅	0.047 μF	Oscillator stabilization	3
C ₁₀₆	0.1 μF	Control amp phase compensation	
X'tal	—	Reference oscillator	7

Notes: 1. Determine the value based on the following formulas.

$$\omega_o \leq \frac{2\pi f_{FG}}{20} \quad (\text{rad/s})$$

$$\frac{R_2}{R_1} = \frac{4}{9.55} \times \frac{J \omega_o N_o R_{nf}}{K_T G_{ctl} V_{R1}}$$

$$C_1 = \frac{1}{10} \frac{1}{\omega_o R_2} \quad [F]$$

$$C_2 = 10 C_1 \quad [F]$$

Where:

f_{FG} = FG frequency (Hz)

N_o = Motor speed (rpm)

J = Motor moment of inertia (kg • cm • s²)

K_T = Motor torque constant (kg • cm/A)

G_{ctl} = Control amp gain (see Electrical Characteristics)

V_{R1} = Charge pump bias voltage (see Electrical Characteristics)

R_{nf} = Current detector resistance (Ω)

2. Select these values so that the Hall effect amplifier in-phase and differential input voltage ranges are satisfied.
3. Unnecessary with crystal frequencies of 4.0 MHz and under.
4. Current control functions according to the following formula.

$$I_o \text{ max} = \frac{V_{ref1}}{R_{nf}} \text{ A}$$

Here, V_{ref1} is the current control reference voltage (see Electrical Characteristics).

5. Locate as close to the IC as possible.
6. Determine the value based on the following formula:

$$C_{103} \geq \frac{200}{f_{FG}} \quad (\mu F)$$

7. The relation between the crystal frequency and f_{FG} is as follows:

$$f_{osc} = \frac{2083.5 D_1 f_{FG}}{D_2} \quad (\text{Hz})$$

Here, D₁ and D₂ specify the division ratio, and their relation to the voltage applied to the D select terminal is as follows:

	D ₁ select (pin 25)				D ₂ select (pin 19)		
	H	M	L		H	M	L
D ₁	1/2	1/4	1/16	D ₂	1/16	1/32	/64



Timing Charts

1. Hall Effect Amplifier Input vs. Output Voltage and Current

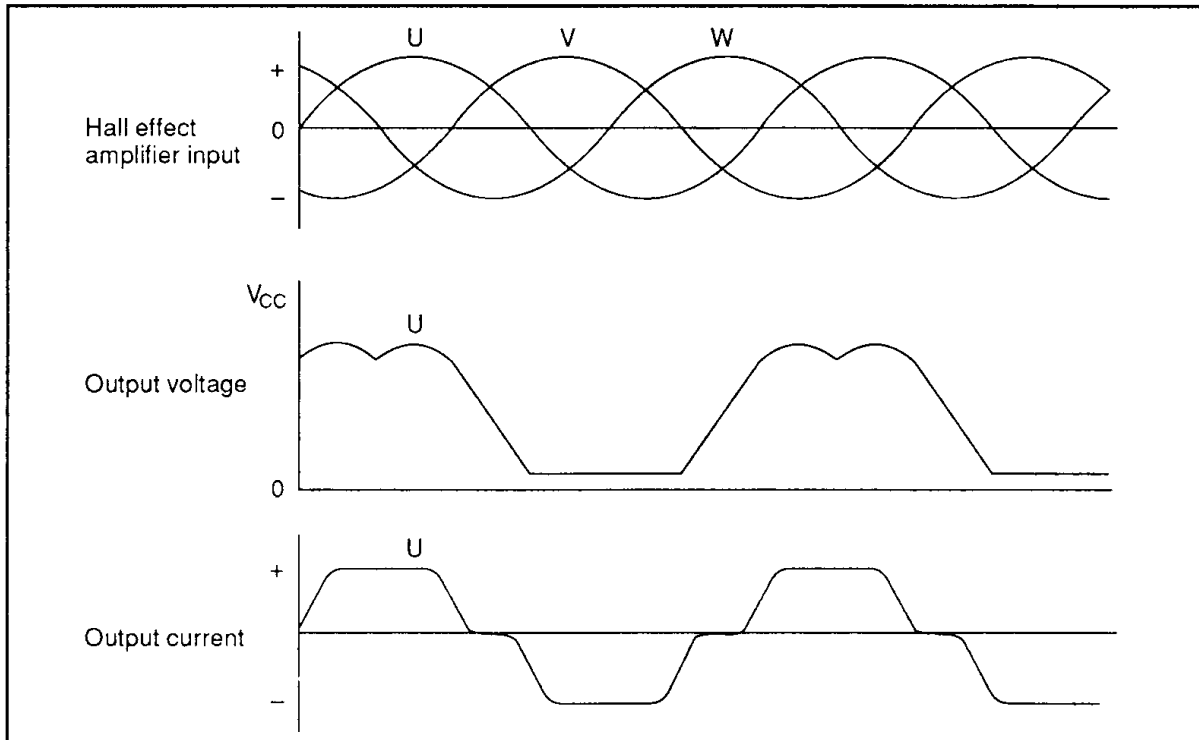

2. Brake Operation and Status Output

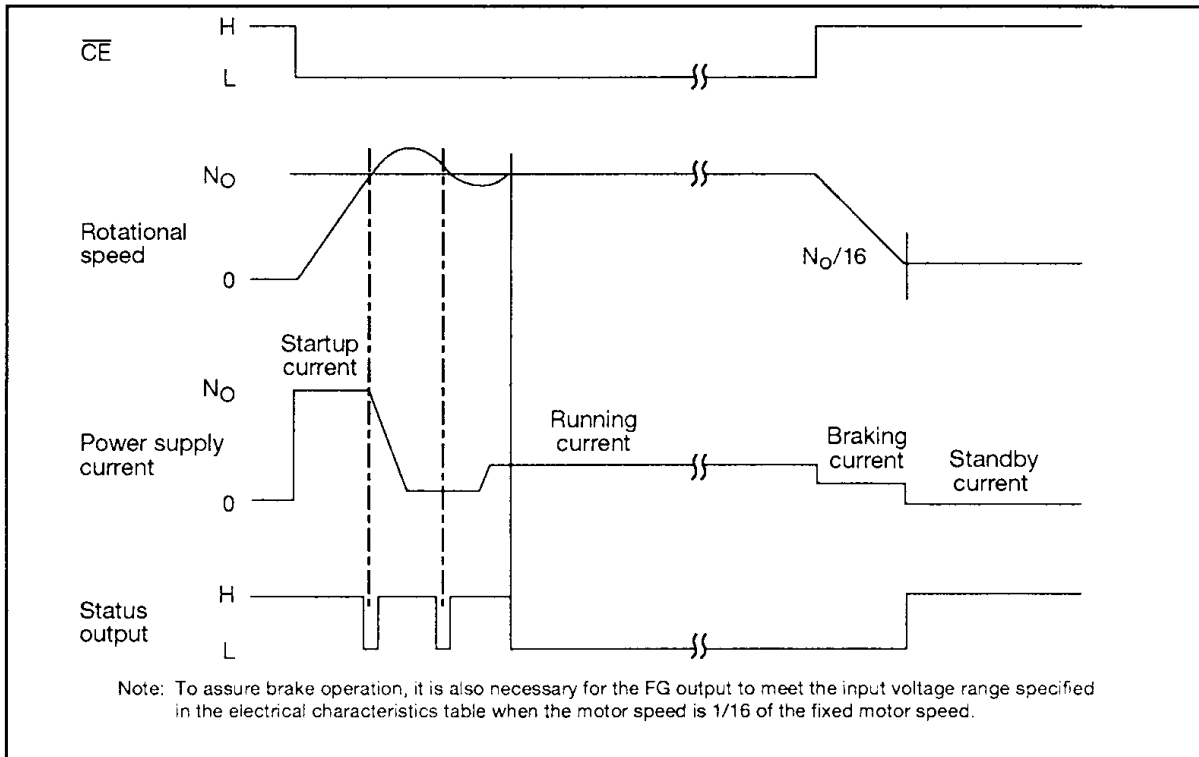

Absolute Maximum Ratings (Ta = 25°C)

Item	Symbol	Rating	Units	Notes
Power supply voltage	V _{CC}	+15	V	1
Input voltage	V _{in}	0 to V _{CC}	V	2
Instantaneous output current	I _{op}	1.5	A	3
Normal output current	I _{doc}	1.0	A	
Allowable dissipation	P _t	2	W	4
Junction temperature	T _j	+150	°C	5
Storage temperature	T _{stg}	-55 to +125	°C	

The absolute maximum ratings are limiting values, to be applied individually, beyond which the device may be permanently damaged. Functional operation under any of these conditions is not guaranteed. Exposing a circuit to its absolute maximum rating for extended periods of time may affect the device's reliability.

- Notes: 1. The operating voltage range is as follows: V_{CC} = 4.25 to 13.8 V
 2. Applies to \overline{CE} , D₁, and D₂ pins.
 3. Refer to the Safe Operating Range figure in the Reference Data Section. Operating locus must be within the ASO.
 4. This is the allowable value when T_C is 136°C. However, thermal resistance is as follows:
 $\theta_{j-c} \leq 7^\circ\text{C/W}$
 $\theta_{j-a1} \leq 15^\circ\text{C/W}$ (When a metal base substrate is used.)
 $\theta_{j-a2} \leq 62^\circ\text{C/W}$ (When a glass epoxy substrate is used.)
 5. The operating temperature range is as follows:
 T_{opr} = 0 to 125°C.

Electrical Characteristics (Ta = 25°C, V_{CC} = 12 V)

Item	Symbol	Min	Typ	Max	Units	Measurement Conditions	Applicable Pins	Notes	
Current drawn	I _{CC0}	—	3	5	mA	$\overline{CE} = H, V_{CC} = 13.8\text{ V}$	12,14	1	
	I _{CC}	—	20	25	mA	$\overline{CE} = L, V_{CC} = 13.8\text{ V}$			
CE	Input current	I _{in1}	—	±50	μA	V _{in} = 0 to 12 V	13		
	Input high voltage	V _{ih1}	2.0	—	—	Disable			
	Input low voltage	V _{il1}	—	—	0.8	Enable			
D ₁ and D ₂ select	Input current	I _{in2}	—	±0.35	mA	V _{in} = 0 to 5 V	19,25		
	Input high voltage	V _{ih2}	3.5	—	—	V			
	Input middle voltage	V _{im2}	1.2	—	3.0	V			
	Input low voltage	V _{il2}	—	—	0.8	V			
Hall effect amp	Input resistance	R _{hi}	7	10	13	kΩ	3 to 6, 9,10		
	In-phase input voltage range	V _{ch}	1.5	—	V _{CC} -2	V			
	Differential input voltage range	V _{dh}	60	—	200	mV _{pp}			
	Leakage current	I _{CER}	—	—	0.1	mA	V _{CE} = 15 V	2,8,11	
Output amp	Saturation voltage	V _{sat1}	—	1.2	1.8	V	I _O = 1.0	2	
		V _{sat2}	—	1.0	1.2	V	I _O = 0.35 A		
Buffer control amp	Voltage gain	G _{ct1}	-7	-9	-11	dB	12	3	
	Reference voltage	V _{ref1}	0.216	0.24	0.264	V	R _{nf} = 1 Ω		
		V _{ref2}	2.1	2.3	2.5	V			



HA13491S

Electrical Characteristics (Ta = 25°C, VCC = 12 V)

Item	Symbol	Min	Typ	Max	Units	Measurement Conditions	Applicable Pins	Notes
Charge pump	R1 voltage	V _{R1}	1.15	1.25	1.35	V	R1 = 3.3 Ω	26
	Charging current	I ₊	—	95	—	μA	R1 = 3.3 Ω	1
	Discharge current	I ₋	—	-95	—	μA	R1 = 3.3 Ω	
	Current ratio	I ₊ /I ₋	—	1.0	—	—		
	Clamp voltage	V _{max}	0.58	0.78	0.88	V		4
Leakage current	I _{off}	—	—	±60	nA			
FG amp	Input voltage range	V _{FG}	10	—	60	mV _{PP}	CE = L	22,23
			2	—	—		Brake mode	
	Noise margin	n _d	—	—	2	mV _{PP}	CE = L	
		n _c	1.0	—	—	V _{PP}	Brake mode	
OSC	Oscillator frequency range	f _{osc}	—	—	8.0	MHz	Crystal oscillator	18
	Oscillator frequency error	Δf _{osc}	—	—	±0.1	%	4 MHz crystal oscillator	
Discriminator	Number of counts	N	—	2084	—	—		
	Operating frequency	f _d	—	—	500	KHz		
FG monitor status output	Leakage current	I _{oh}	—	—	±20	μA	V _{oh} = 15 V	16,24
	Output low voltage	V _{ol}	—	—	0.4	V	I _O = 2 mA	
OTSD	Operating temperature	T _{sd}	125	150	—	°C		

- Notes: 1. Specified as the sum of the pin 12 and 14 currents.
 2. Specified as the sum of the upper and lower saturation voltages.
 3. Refer to figure 1, where:

$$G_{ctl} = \frac{\Delta V_{Rnf}}{\Delta V_{pin1}}$$

4. Specified as the difference with V_{ref}.

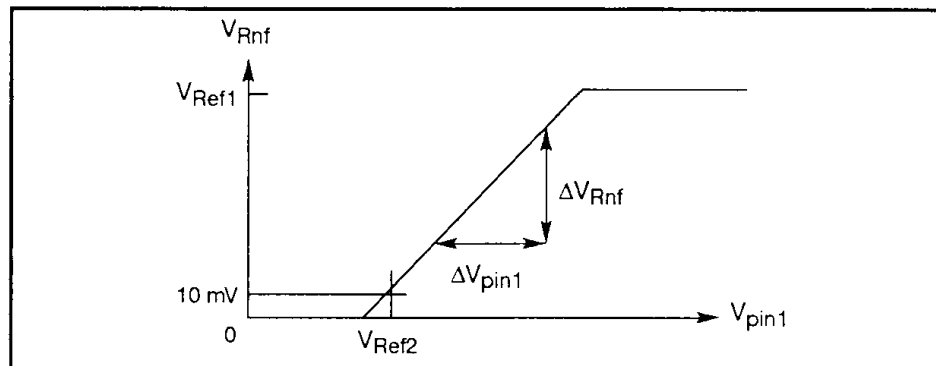

Figure 1 V_{Rnf} vs V_{pin1}

Reference Data

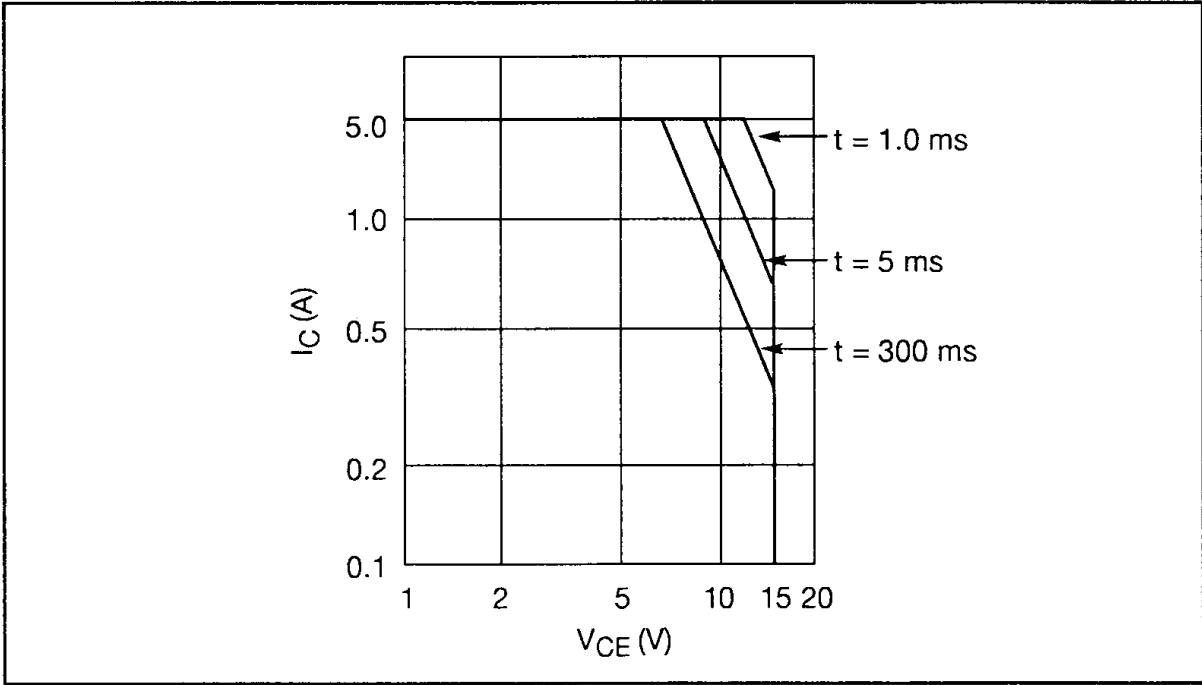

Figure 2 Output Transistor Safe Operating Range

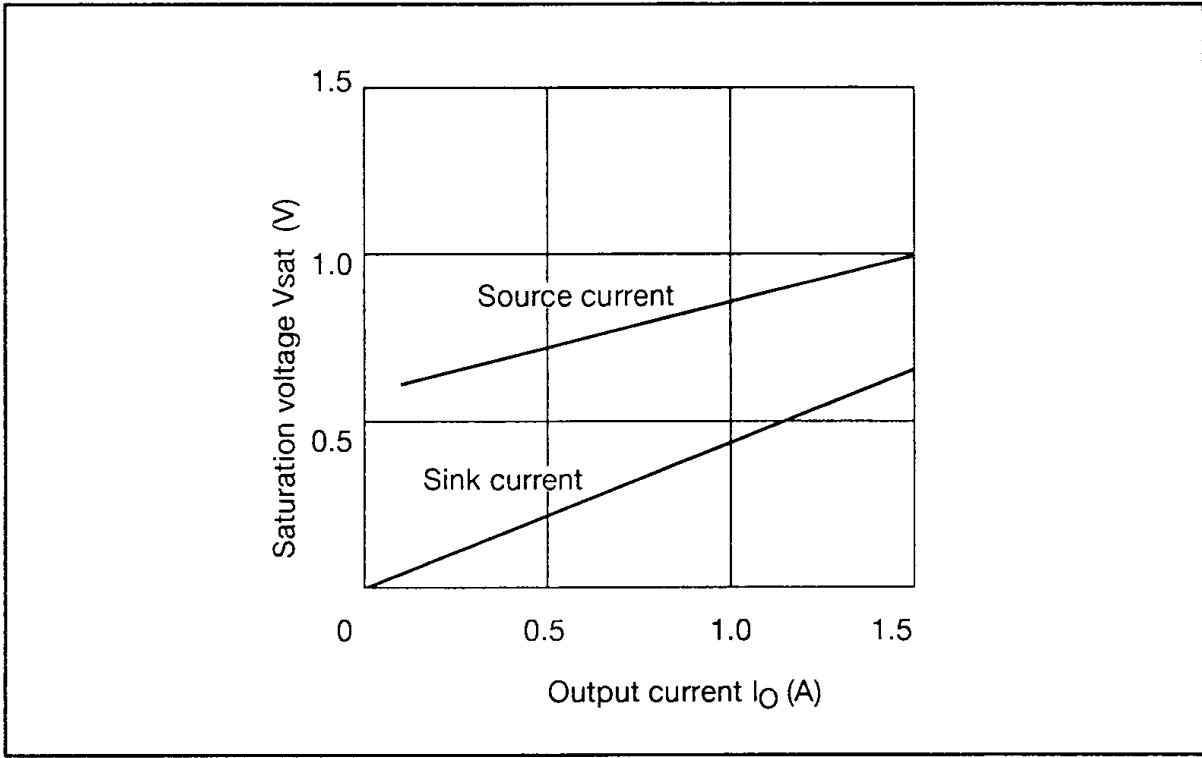

Figure 3 Output Transistor Saturation Characteristics



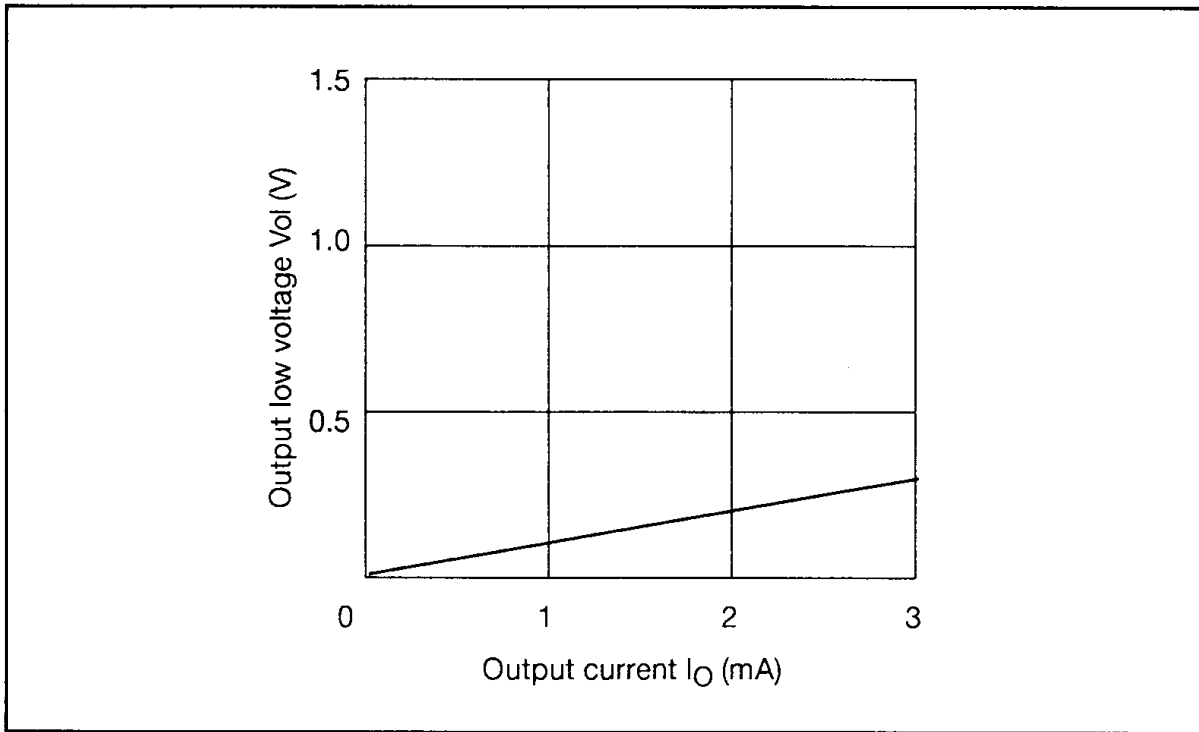

Figure 4 FG Monitor and Status Output Voltage Characteristics

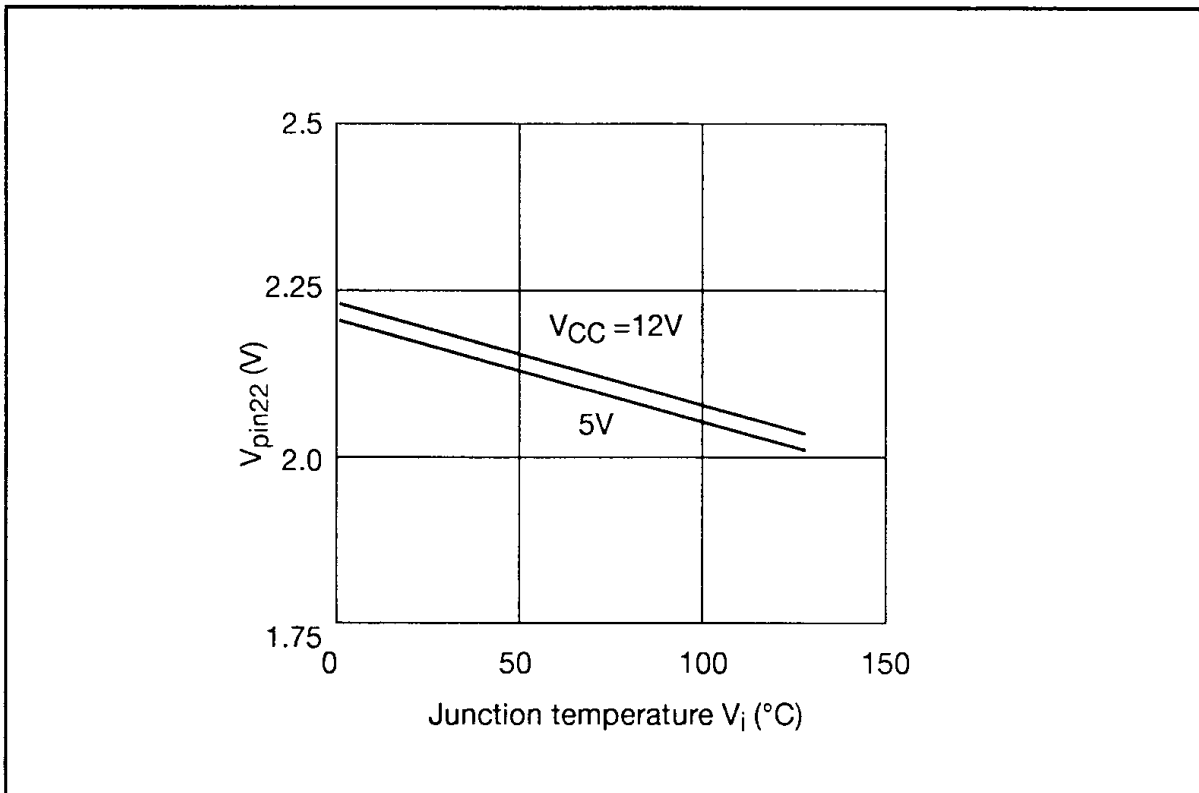

Figure 5 FG Amp Bias Voltage Temperature Characteristics

This datasheet has been downloaded from:

www.DatasheetCatalog.com

Datasheets for electronic components.



LittleDiode supplies new, hard to find or obsolete electronic components and semiconductors all over the world.

With over two million different components listed you are sure to find the part you need.

Feel free to visit us today at our online store:

LittleDiode.com

Looking forward to providing you with the best possible service.