

DS1645/DS3645, DS1675/DS3675



Memory Support

T-52-15

DS1645/DS3645, DS1675/DS3675 Hex TRI-STATE® TTL to MOS Latches/Drivers

General Description

The DS1645/DS3645 and DS1675/DS3675 are hex MOS latches/drivers with outputs designed to drive large capacitive loads up to 500 pF associated with MOS memory systems. PNP input transistors are used to reduce input currents, allowing the large fan-out to these drivers needed in memory systems. The circuit has Schottky-clamped transistor logic for minimum propagation delay, and TRI-STATE® outputs which allow bus operation.

The DS1645/DS3645 has a 15 Ω resistor in series with the outputs to dampen transients caused by the fast switching output circuit. The DS1675/DS3675 has a direct, low impedance output for use with or without an external resistor.

The circuit employs a fall-through-latch which captures the data in parallel with the output, thereby eliminating the delay normally encountered in other latch circuits. The DS1645/DS3645 and DS1675/DS3675 may be used for input address lines or input/output data lines of a MOS memory system.

Features

- TTL compatible inputs
- PNP inputs minimize loading
- Capacitance-driving outputs
- TRI-STATE outputs
- Built-in damping resistor (DS1645/DS3645)

Logic and Connection Diagrams

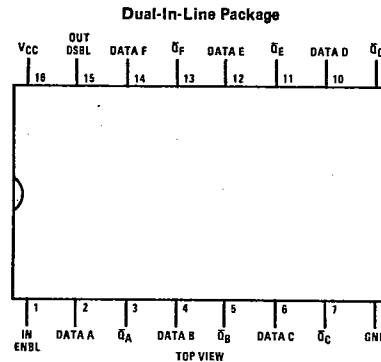
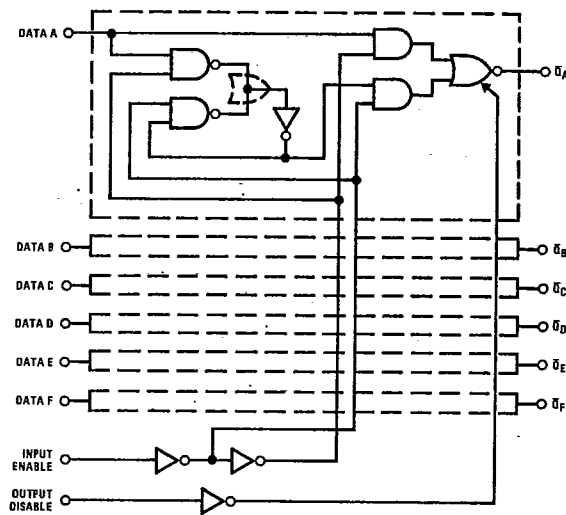

Order Number DS1645J, DS1675J, DS3645J, DS3675J, DS3645N or DS3675N
See NS Package J16A or N16A

Truth Table

INPUT ENABLE	OUTPUT DISABLE	DATA	OUTPUT	OPERATION
1	0	1	0	Data Feed-Through
1	0	0	1	Data Feed-Through
0	0	X	Q	Latched to Data Present when Enable Went Low
X	1	X	Hi-Z	High Impedance Output

X = Don't care
Hi-Z = TRI-STATE mode

Absolute Maximum Ratings (Note 1)

Operating Conditions

T-52-15

Supply Voltage, V _{CC}	7V
Logical "1" Input Voltage	7V
Logical "0" Input Voltage	-1.5V
Storage Temperature Range	-65°C to +150°C
Maximum Power Dissipation* at 25°C	
Cavity Package	1433 mW
Molded Package	1362 mW
Lead Temperature (Soldering, 10 seconds)	300°C

Supply Voltage (V _{CC})	4.5	5.5	V
Temperature (T _A)			
DS1645, DS1675	-55	+125	°C
DS3645, DS3675	0	+70	°C

*Derate cavity package 9.6 mW/°C above 25°C; derate molded package 10.9 mW/°C above 25°C.

Electrical Characteristics (Notes 2 and 3)

PARAMETER	CONDITIONS		MIN	TYP	MAX	UNITS	
V _{IN(1)}	Logical "1" Input Voltage		2.0			V	
V _{IN(0)}	Logical "0" Input Voltage				0.8	V	
I _{IN(1)}	V _{IN} = 5.5V V _{CC} = 5.5V	Enable Inputs		0.1	40	μA	
		Data Inputs		0.2	80	μA	
I _{IN(0)}	V _{IN} = 0.5V V _{CC} = 5.5V	Enable Inputs		-50	-250	μA	
		Data Inputs		-100	-500	μA	
V _{CLAMP}	Input Clamp Voltage		V _{CC} = 4.5V, I _{IN} = -18 mA		-0.75	-1.2	V
V _{OH}	Logical "1" Output Voltage (No Load)	V _{CC} = 4.5V, I _{OH} = -10 μA	DS1645, DS1675	2.7	3.6	V	
			DS3645, DS3675	2.8	3.6	V	
V _{OL}	Logical "0" Output Voltage (No Load)	V _{CC} = 4.5V, I _{OL} = 10 μA	DS1645, DS1675		0.25	0.4	V
			DS3645, DS3675		0.25	0.35	V
V _{OH}	Logical "1" Output Voltage (With Load)	V _{CC} = 4.5V, I _{OH} = -1.0 mA	DS1645	2.4	3.5	V	
			DS1675	2.5	3.5	V	
			DS3645	2.6	3.5	V	
			DS3675	2.7	3.5	V	
V _{OL}	Logical "0" Output Voltage (With Load)	V _{CC} = 4.5V, I _{OL} = 20 mA	DS1645		0.6	1.1	V
			DS1675		0.4	0.5	V
			DS3645		0.6	1.0	V
			DS3675		0.4	0.5	V
I _{ID}	Logical "1" Drive Current		V _{CC} = 4.5V, V _{OUT} = 0V, (Note 4)		-250	mA	
I _{OD}	Logical "0" Drive Current		V _{CC} = 4.5V, V _{OUT} = 4.5V, (Note 4)		150	mA	
I _{HZ}	TRI-STATE Output Current		V _{OUT} = 0.4V to 2.4V, Output Disable = 2.0V		-40	40	μA
I _{CC}	Power Supply Current	V _{CC} = 5.5V	Output Disable = 3V All Other Inputs = 0V		60	100	mA
			Input Enable = 3V All Other Inputs = 0V		40	80	mA

Note 1: "Absolute Maximum Ratings" are those values beyond which the safety of the device cannot be guaranteed. Except for "Operating Temperature Range" they are not meant to imply that the devices should be operated at these limits. The table of "Electrical Characteristics" provides conditions for actual device operation.

Note 2: Unless otherwise specified min/max limits apply across the -55°C to +125°C temperature range for the DS1645 and DS1675 and across the 0°C to +70°C range for the DS3645 and DS3675. All typical values are for T_A = 25°C and V_{CC} = 5V.

Note 3: All currents into device pins shown as positive, out of device pins as negative, all voltages referenced to ground unless otherwise noted. All values shown as max or min on absolute value basis.

Note 4: When measuring output drive current and switching response for the DS1675 and DS3675 a 15 ohm resistor should be placed in series with each output. This resistor is internal to the DS1645/DS3645, and need not be added.

DS1645/DS3645, DS1675/DS3675

6

Switching Characteristics $V_{CC} = 5V, T_A = 25^\circ C$, unless otherwise noted. (Note 4)

7-52-15

DS1645/DS3645, DS1675/DS3675

PARAMETER		CONDITIONS		MIN	TYP	MAX	UNITS
tS+—	Storage Delay Negative Edge	(Figure 1)	$C_L = 50 \text{ pF}$		4.5	7	ns
			$C_L = 500 \text{ pF}$		8	12	ns
tS—+	Storage Delay Positive Edge	(Figure 1)	$C_L = 50 \text{ pF}$		6	8	ns
			$C_L = 500 \text{ pF}$		9	13	ns
tF	Fall Time	(Figure 1)	$C_L = 50 \text{ pF}$		5	8	ns
			$C_L = 500 \text{ pF}$		21	35	ns
tR	Rise Time	(Figure 1)	$C_L = 50 \text{ pF}$		6	9	ns
			$C_L = 500 \text{ pF}$		22	35	ns
tSET-UP	Set-Up Time on Data Input Before Input Enables Goes Low			10	0		ns
tHOLD	Hold Time on Data Input After Input Enable Goes Low			15	5		ns
tW	Minimum Width of Enable Pulse to Latch Data			20	5		ns
tZL	Delay from Disable Input to Logical "0" Level (from High Impedance State)	$C_L = 50 \text{ pF}, R_L = 2 \text{ k}\Omega \text{ to } V_{CC}$, (Figure 2)			10	15	ns
tZH	Delay from Disable Input to Logical "1" Level (from High Impedance State)	$C_L = 50 \text{ pF}, R_L = 2 \text{ k}\Omega \text{ to Ground}$, (Figure 2)			10	15	ns
tLZ	Delay from Disable Input to High Impedance State (from Logical "0" Level)	$C_L = 50 \text{ pF}, R_L = 400\Omega \text{ to } V_{CC}$, (Figure 3)			16	25	ns
tHZ	Delay from Disable Input to High Impedance State (from Logical "1" Level)	$C_L = 50 \text{ pF}, R_L = 400\Omega \text{ to Ground}$, (Figure 3)			16	25	ns

Schematic Diagram

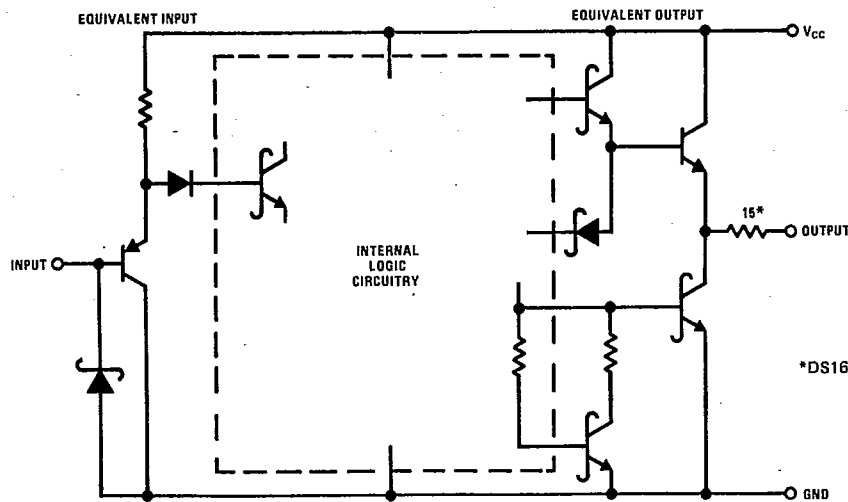

AC Test Circuits and Switching Time Waveforms

T-52-15

DS1645/DS3645, DS1675/DS3675

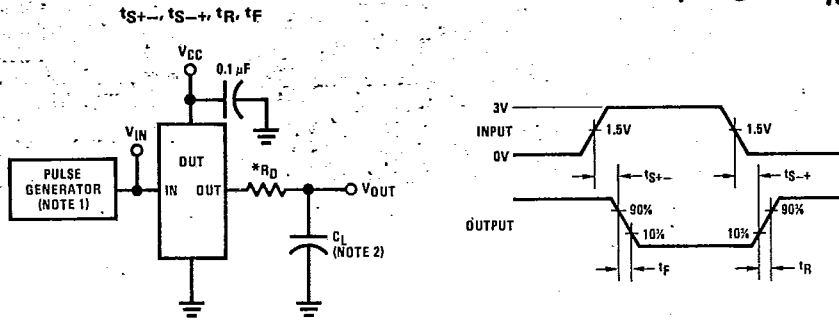

Note 1: The pulse generator has the following characteristics: Z_{OUT} = 50 Ω and PRR ≤ 1 MHz. Rise and fall times between 10% and 90% points ≤ 5 ns.
 Note 2: C_L includes probe and jig capacitance.

FIGURE 1

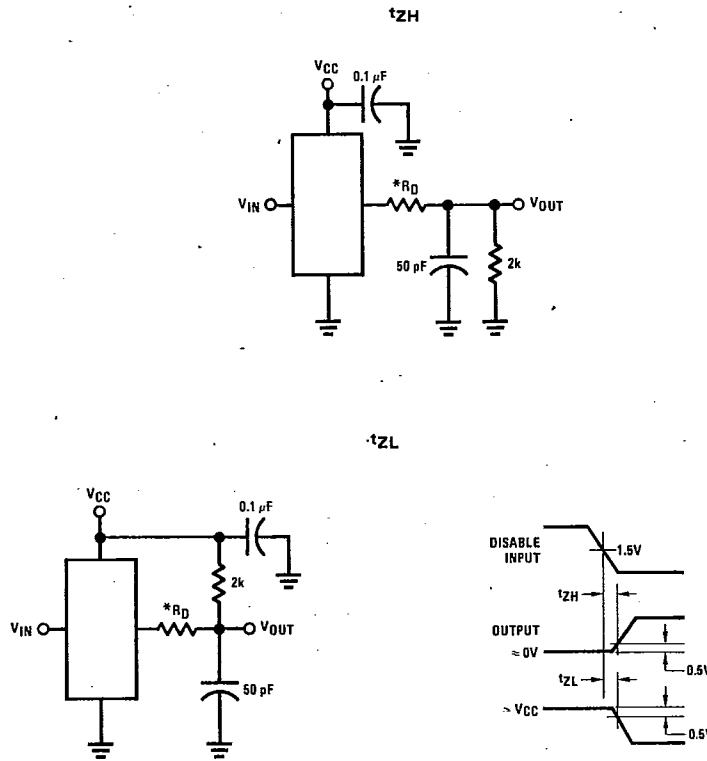

*Internal on DS1645 and DS3645

FIGURE 2

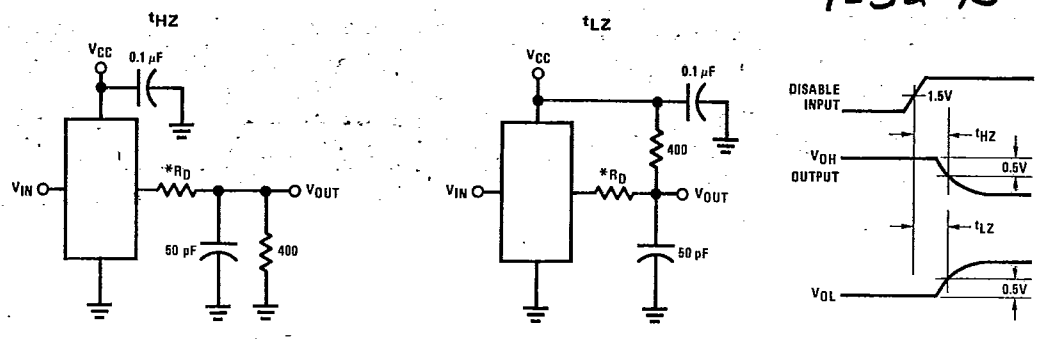

*Internal on DS1645 and DS3645

FIGURE 3

Operating Waveforms

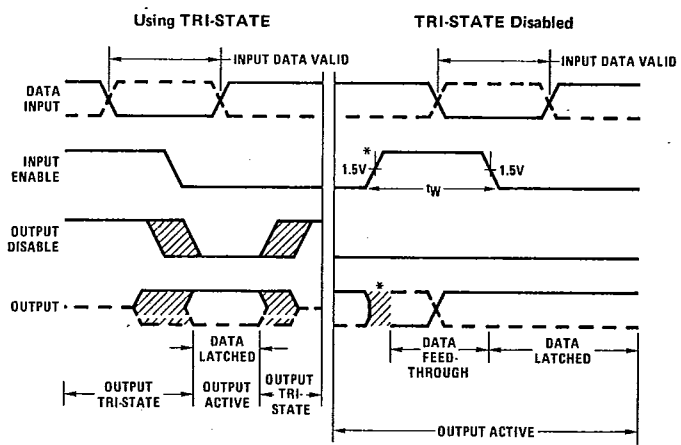

*When the Input Enable makes a positive transition the output will be indeterminate for a short duration. The positive transition of the Input Enable normally occurs during a don't-care timing state at the output.

Typical Applications

The DS3645 and DS3675 latch/driver has TRI-STATE outputs, which allows the outputs to be tied with those of another TRI-STATE driver, such as the DS3646 and

DS3676 refresh counter. The DS3645 and DS3675 can be disabled while the alternate driver controls the address lines into the memory system.

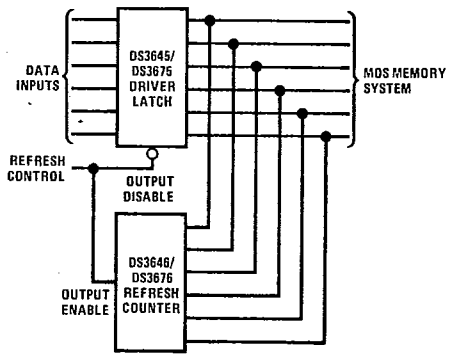

This datasheet has been downloaded from:

www.DatasheetCatalog.com

Datasheets for electronic components.

National Semiconductor was acquired by Texas Instruments.

http://www.ti.com/corp/docs/investor_relations/pr_09_23_2011_national_semiconductor.html

This file is the datasheet for the following electronic components:

DS3675 - <http://www.ti.com/product/ds3675?HQS=TI-null-null-dscatalog-df-pf-null-ww>



LittleDiode supplies new, hard to find or obsolete electronic components and semiconductors all over the world.

With over two million different components listed you are sure to find the part you need.

Feel free to visit us today at our online store:

LittleDiode.com

Looking forward to providing you with the best possible service.