

TV VERTICAL DEFLECTION OUTPUT CIRCUIT

- POWER AMPLIFIER
- FLYBACK GENERATOR
- THERMAL PROTECTION
- REFERENCE VOLTAGE

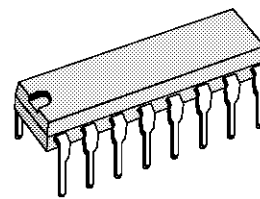

DIP16
(Plastic Package)

ORDER CODE : TDA8173

DESCRIPTION

The TDA8173 is a monolithic integrated circuit in POWERDIP package. It is a high efficiency power booster for direct driving of vertical windings of TV yokes. It is intended for use in Color and B & W television sets as well as in monitors, and displays.

PIN CONNECTIONS (top view)

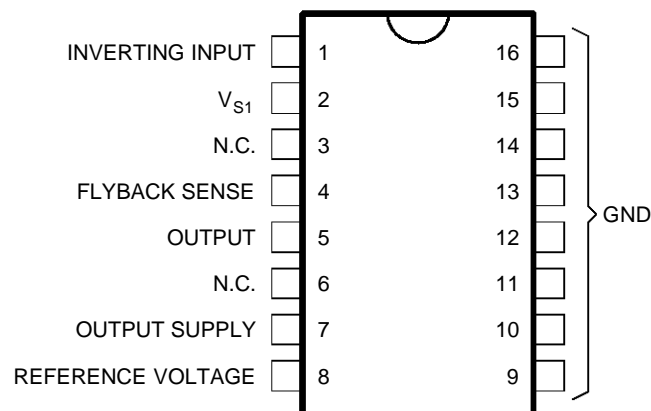

8173-01.EPS

TDA8173

BLOCK DIAGRAM

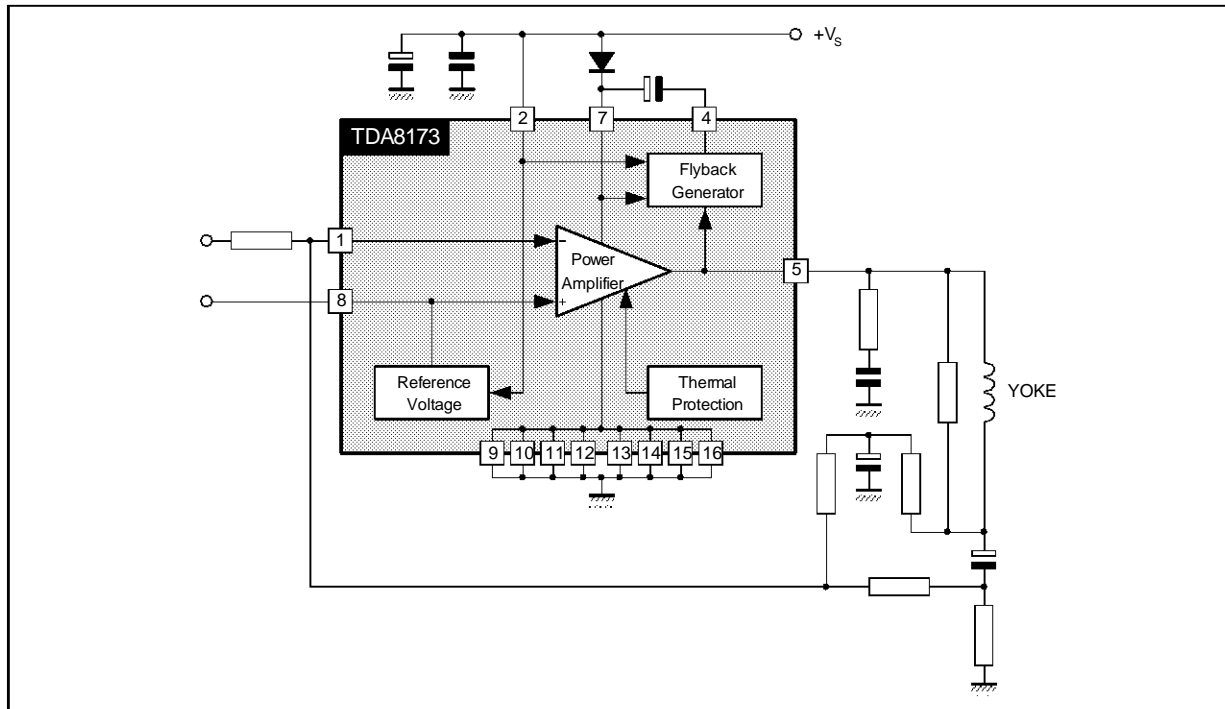

8173-02.EPS

ABSOLUTE MAXIMUM RATINGS

Symbol	Parameter	Value	Unit
V_S	Supply Voltage (pin 2)	35	V
V_5	Flyback Peak Voltage	60	V
V_4	Voltage at Pin 4	$+ V_S$	
V_1, V_8	Amplifier Input Voltage	$+ V_S$ $- 0.5$	V
I_o	Output Peak Current (non repetitive, $t = 2$ ms)	2.5	A
I_o	Output Peak Current at $f = 50$ or 60 Hz, $t \leq 10$ μ s	3	A
I_o	Output Peak Current at $f = 50$ or 60 Hz, $t > 10$ μ s	2	A
I_4	Pin 4 DC Current at $V_5 < V_2$	100	mA
I_4	Pin 4 Peak to Peak Flyback Current at $f = 50$ or 60 Hz, $t_{fly} \leq 1.5$ ms	3	A
P_{tot}	Total Power Dissipation at $T_{case} = 60$ °C	6	W
T_{stg}, T_j	Storage and Junction Temperature	$- 40$ to 150	°C

8173-01.TBL

THERMAL DATA

Symbol	Parameter	Value	Unit
$R_{th(j-c)}$	Thermal Resistance Junction-case	Max. 15	°C/W
$R_{th(j-a)}$	Thermal Resistance Junction-ambient	Max. 70	°C/W

8173-02.TBL

ELECTRICAL CHARACTERISTICS

(refer to the test circuits, $V_S = 35V$, $T_{amb} = 25^{\circ}C$ unless otherwise specified)

Symbol	Parameter	Test Conditions	Min.	Typ.	Max.	Unit
I_2	Pin 2 Quiescent Current	$I = 0, I_5 = 0$		8	16	mA
I_7	Pin 7 Quiescent Current	$I = 0, I_5 = 0$		16	36	mA
I_1	Amplifier Input Bias Current	$V_1 = 1 V$		-0.1	-1	μA
V_{4L}	Pin 4 Saturation Voltage to GND	$I_4 = 20 mA$		1		V
V_5	Quiescent Output Voltage	$V_S = 35 V, R_a = 39 k\Omega$		18		V
V_{5L}	Output Saturation Voltage to GND	$I_5 = 1.2 A$		1	1.4	V
		$I_5 = 0.7 A$		0.7	1	V
V_{5H}	Output Saturation Voltage to Supply	$-I_5 = 1.2 A$		1.6	2.2	V
		$-I_5 = 0.7 A$		1.3	1.8	V
T_j	Junction Temperature for Thermal Shut Down			140		$^{\circ}C$
V_8	Reference Voltage			2.2		V
$\frac{\Delta V_8}{\Delta V_S}$	Reference Voltage Drift versus Supply Voltage	$V_S = 15 to 30 V$		1	2	mV

8173-03.TBL

TEST CIRCUITS

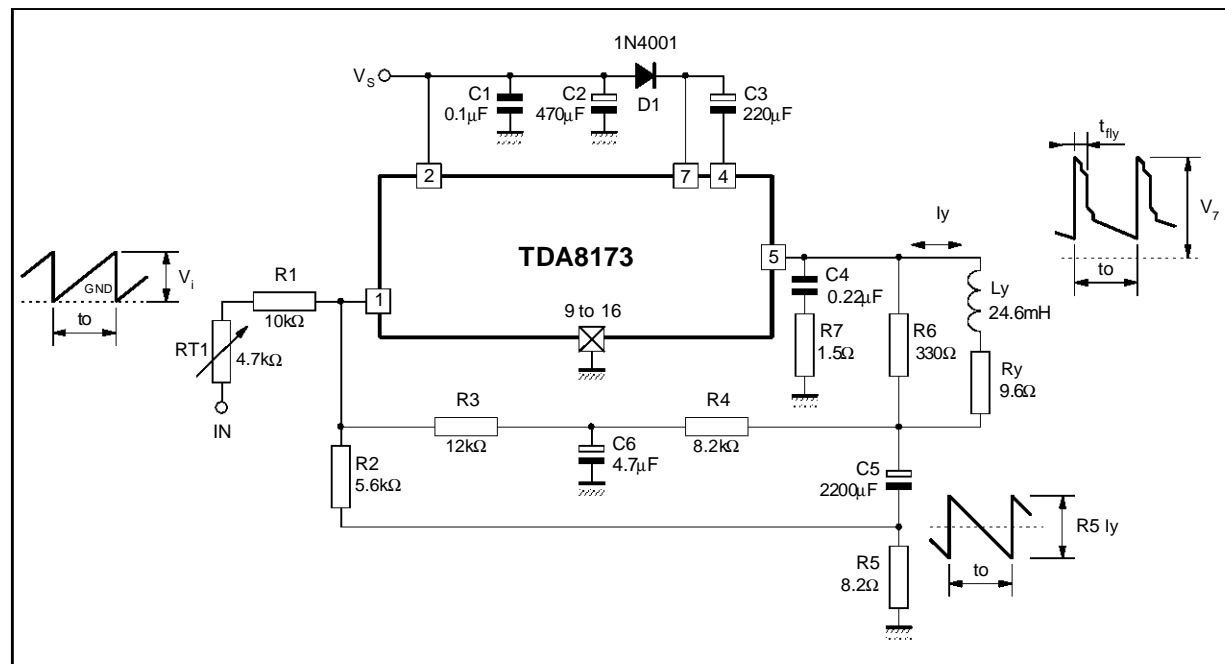

8173-03.EPS

TDA8173

PACKAGE MECHANICAL DATA

16 PINS - PLASTIC DIP

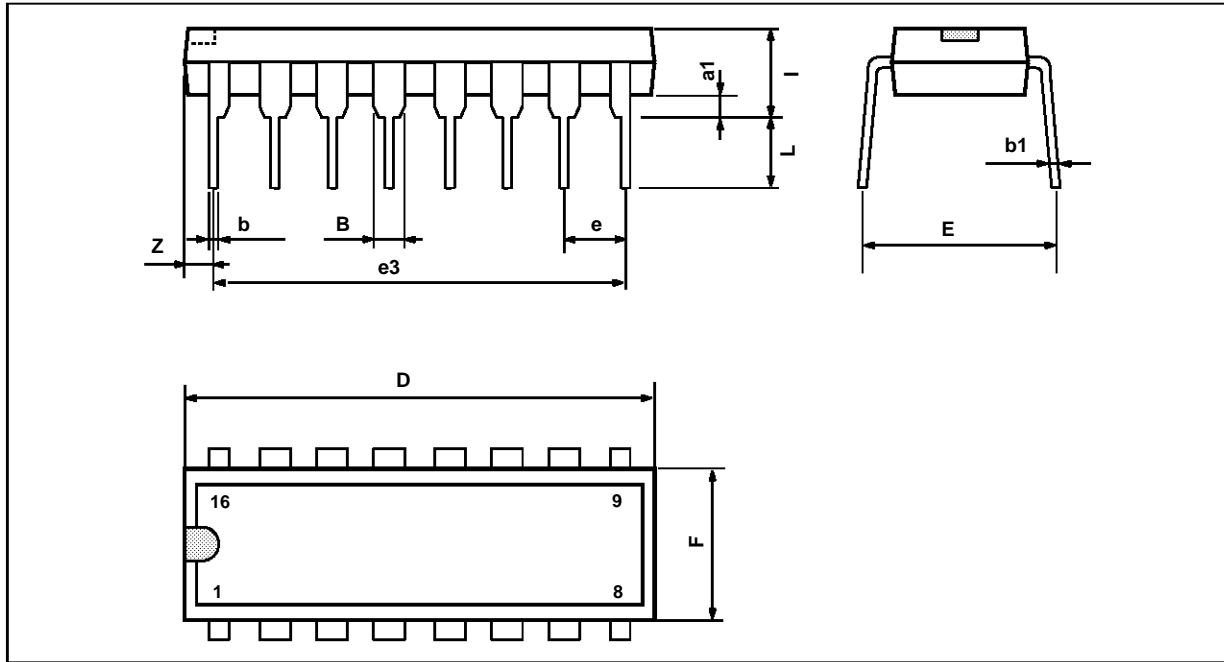

PM-DIP16.EPS

Dimensions	Millimeters			Inches		
	Min.	Typ.	Max.	Min.	Typ.	Max.
a1	0.51			0.020		
B	0.77		1.65	0.030		0.065
b		0.5			0.020	
b1		0.25			0.010	
D			20			0.787
E		8.5			0.335	
e		2.54			0.100	
e3		17.78			0.700	
F			7.1			0.280
i			5.1			0.201
L		3.3			0.130	
Z			1.27			0.050

DIP16.TBL

Information furnished is believed to be accurate and reliable. However, SGS-THOMSON Microelectronics assumes no responsibility for the consequences of use of such information nor for any infringement of patents or other rights of third parties which may result from its use. No licence is granted by implication or otherwise under any patent or patent rights of SGS-THOMSON Microelectronics. Specifications mentioned in this publication are subject to change without notice. This publication supersedes and replaces all information previously supplied. SGS-THOMSON Microelectronics products are not authorized for use as critical components in life support devices or systems without express written approval of SGS-THOMSON Microelectronics.

© 1994 SGS-THOMSON Microelectronics - All Rights Reserved

Purchase of I²C Components of SGS-THOMSON Microelectronics, conveys a license under the Philips I²C Patent. Rights to use these components in a I²C system, is granted provided that the system conforms to the I²C Standard Specifications as defined by Philips.

SGS-THOMSON Microelectronics GROUP OF COMPANIES

Australia - Brazil - China - France - Germany - Hong Kong - Italy - Japan - Korea - Malaysia - Malta - Morocco
The Netherlands - Singapore - Spain - Sweden - Switzerland - Taiwan - Thailand - United Kingdom - U.S.A.