

## 9300/DM9300 4-Bit Parallel-Access Shift Register

### General Description

The 9300 4-bit registers feature parallel inputs, parallel outputs, JK serial inputs, shift/load control input, and a direct overriding clear. The registers have two modes of operation: parallel (broadside) load and shift (in direction Q<sub>A</sub> toward Q<sub>D</sub>).

Parallel loading is accomplished by applying the four bits of data and taking the shift/load control input low. The data is loaded into the associated flip-flops, and appears at the outputs after the positive transition of the clock input. During loading, serial data flow is inhibited.

Shifting is accomplished synchronously when the shift/load control input is high. Serial data for this mode is entered at the JK inputs. These inputs permit the first stage to perform as a JK, D or T-type flip-flop as shown in the function table.

These shift registers are fully compatible with most other TTL and DTL families. All inputs, including the clock, are buffered to lower the drive requirements to one normalized Series 54/74 load.

### Features

- Fully buffered inputs
- Direct overriding clear
- Synchronous parallel load
- Parallel inputs and outputs from each flip-flop
- Positive edge-triggered clocking
- J and K inputs to first stage
- Typical shift frequency—39 MHz

### Connection Diagram

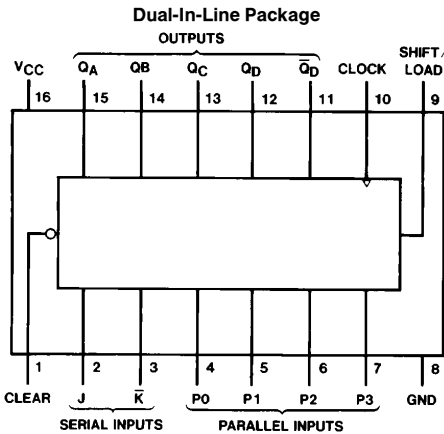

Order Number 9300DMQB,  
9300FMQB or DM9300N  
See NS Package Number  
J16A, N16E or W16A

TL/F/6600-1

### Function Table

Clear	Shift/ Load	Clock	Inputs				Outputs							
			Serial		Parallel				Q <sub>A</sub>	Q <sub>B</sub>	Q <sub>C</sub>	Q <sub>D</sub>	Q <sub>D</sub> <sup>̄</sup>	
			J	K <sup>̄</sup>	P0	P1	P2	P3						
L	X	X	X	X	X	X	X	X	X	L	L	L	L	H
H	L	↑	X	X	a	b	c	d		a	b	c	d	d <sup>̄</sup>
H	H	L	X	X	X	X	X	X		Q <sub>A0</sub>	Q <sub>B0</sub>	Q <sub>C0</sub>	Q <sub>D0</sub>	Q <sub>D0</sub> <sup>̄</sup>
H	H	↑	L	H	X	X	X	X		Q <sub>A0</sub>	Q <sub>A0</sub>	Q <sub>Bn</sub>	Q <sub>Cn</sub>	Q <sub>Cn</sub> <sup>̄</sup>
H	H	↑	L	L	X	X	X	X		L	Q <sub>An</sub>	Q <sub>Bn</sub>	Q <sub>Cn</sub>	Q <sub>Cn</sub> <sup>̄</sup>
H	H	↑	H	H	X	X	X	X		H	Q <sub>An</sub>	Q <sub>Bn</sub>	Q <sub>Cn</sub>	Q <sub>Cn</sub> <sup>̄</sup>
H	H	↑	H	L	X	X	X	X		Q <sub>An</sub> <sup>̄</sup>	Q <sub>An</sub>	Q <sub>Bn</sub>	Q <sub>Bn</sub>	Q <sub>Cn</sub> <sup>̄</sup>

H = High Level (Steady State)

L = Low Level (Steady State)

X = Don't Care

↑ = Transition from low-to-high level

a, b, c, d, = The level of steady state input at P0, P1, P2, or P3 respectively.

Q<sub>A0</sub>, Q<sub>B0</sub>, Q<sub>C0</sub>, Q<sub>D0</sub> = The level of Q<sub>A</sub>, Q<sub>B</sub>, Q<sub>C</sub>, or Q<sub>D</sub>, respectively before the indicated steady state input conditions were established.

Q<sub>An</sub>, Q<sub>Bn</sub>, Q<sub>Cn</sub> = The level of Q<sub>A</sub>, Q<sub>B</sub>, Q<sub>C</sub>, respectively, before the most recent ↑ transition of the clock.

## Absolute Maximum Ratings (Note)

If Military/Aerospace specified devices are required, please contact the National Semiconductor Sales Office/Distributors for availability and specifications.

Supply Voltage	7V
Input Voltage	5.5V
Storage Temperature Range	-65°C to +150°C
Operating Free Air Temperature Range	
Military	-55°C to +125°C
Commercial	0°C to +70°C

Note: The "Absolute Maximum Ratings" are those values beyond which the safety of the device cannot be guaranteed. The device should not be operated at these limits. The parametric values defined in the "Electrical Characteristics" table are not guaranteed at the absolute maximum ratings. The "Recommended Operating Conditions" table will define the conditions for actual device operation.

## Recommended Operating Conditions

Symbol	Parameter	Military			Commercial			Units
		Min	Nom	Max	Min	Nom	Max	
V <sub>CC</sub>	Supply Voltage	4.5	5	5.5	4.75	5	5.25	V
V <sub>IH</sub>	High Level Input Voltage	2			2			V
V <sub>IL</sub>	Low Level Input Voltage			0.8			0.8	V
I <sub>OH</sub>	High Level Output Current			-0.48			-0.8	mA
I <sub>OL</sub>	Low Level Output Current			9.6			16	mA
f <sub>CLK</sub>	Clock Frequency (Note 5)	0		30	0		30	MHz
t <sub>w</sub>	Pulse Width (Note 5)	Clock	17		16	11		ns
		Clear	25		30	15		
t <sub>SU</sub>	Setup Time (Note 5)	S/L	36		30	13		ns
		Data	18		20	13		
		Clear	36		30	13		
t <sub>H</sub>	Data Hold Time (Note 5)	0			0	-11		ns
t <sub>REL</sub>	S/L Release Time (Notes 1 and 5)	10			10			ns
T <sub>A</sub>	Free Air Operating Temperature	-55		125	0		70	°C

## Electrical Characteristics over recommended operating free air temperature range (unless otherwise noted)

Symbol	Parameter	Conditions	Min	Typ (Note 2)	Max	Units
V <sub>I</sub>	Input Clamp Voltage	V <sub>CC</sub> = Min, I <sub>I</sub> = -12 mA			-1.5	V
V <sub>OH</sub>	High Level Output Voltage	V <sub>CC</sub> = Min, I <sub>OH</sub> = Max V <sub>IL</sub> = Max, V <sub>IH</sub> = Min	2.4			V
V <sub>OL</sub>	Low Level Output Voltage	V <sub>CC</sub> = Min, I <sub>OL</sub> = Max V <sub>IH</sub> = Min, V <sub>IL</sub> = Max			0.4	V
I <sub>I</sub>	Input Current @ Max Input Voltage	V <sub>CC</sub> = Max, V <sub>I</sub> = 5.5V			1	mA
I <sub>IH</sub>	High Level Input Current	V <sub>CC</sub> = Max, V <sub>I</sub> = 2.4V	Input		40	μA
			CP Input		80	
			PE Input		92	
I <sub>IL</sub>	Low Level Input Current	V <sub>CC</sub> = Max, V <sub>I</sub> = 0.4V	Input		-1.6	mA
			CP Input		-3.2	
			PE Input		-3.7	
I <sub>OS</sub>	Short Circuit Output Current	V <sub>CC</sub> = Max (Note 3)	MIL	-20	-80	mA
			COM	-18	-55	
I <sub>CC</sub>	Supply Current	V <sub>CC</sub> = Max (Note 4)	MIL		86	mA
			COM		92	

**Note 1:** RELEASE TIME: t<sub>RELEASE</sub> is defined as the maximum time allowed for the logic level to be present at the logic input prior to the clock transition from low to high in order for the flip-flop(s) not to respond.

**Note 2:** All typicals are at V<sub>CC</sub> = 5V, T<sub>A</sub> = 25°C.

**Note 3:** Not more than one output should be shorted at a time.

**Note 4:** With all outputs open, SHIFT/LOAD grounded, and 4.5V applied to J, K, and data inputs, I<sub>CC</sub> is measured by applying momentary ground, then 4.5V to CLEAR, and then to CLOCK.

**Note 5:** T<sub>A</sub> = 25°C and V<sub>CC</sub> = 5V.

**Switching Characteristics** at  $V_{CC} = 5V$  and  $T_A = 25^\circ C$  (See Section 1 for Test Waveforms and Output Load)

Symbol	Parameter	From (Input) To (Output)	Military		Commercial		Units
			$R_L = 400\Omega, C_L = 15\text{ pF}$		$R_L = 400\Omega, C_L = 15\text{ pF}$		
			Min	Max	Min	Max	
$f_{MAX}$	Maximum Clock Frequency		30		30		MHz
$t_{PLH}$	Propagation Delay Time Low to High Level Output	Clock to Output		20		22	ns
$t_{PHL}$	Propagation Delay Time High to Low Level Output	Clock to Output		24		26	ns
$t_{PHL}$	Propagation Delay Time High to Low Level Output	Clear to Output		37		30	ns

# Schematic Diagram

DM9300

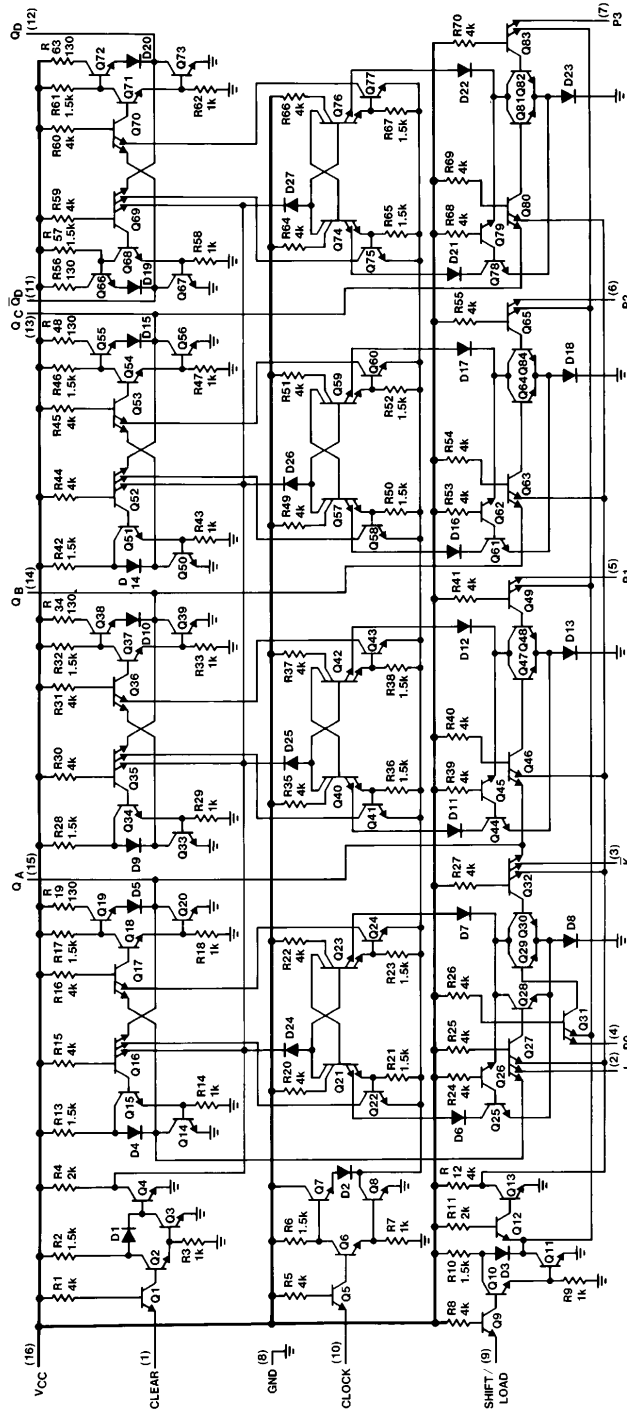

TL/F/6600-2

**Physical Dimensions** inches (millimeters)

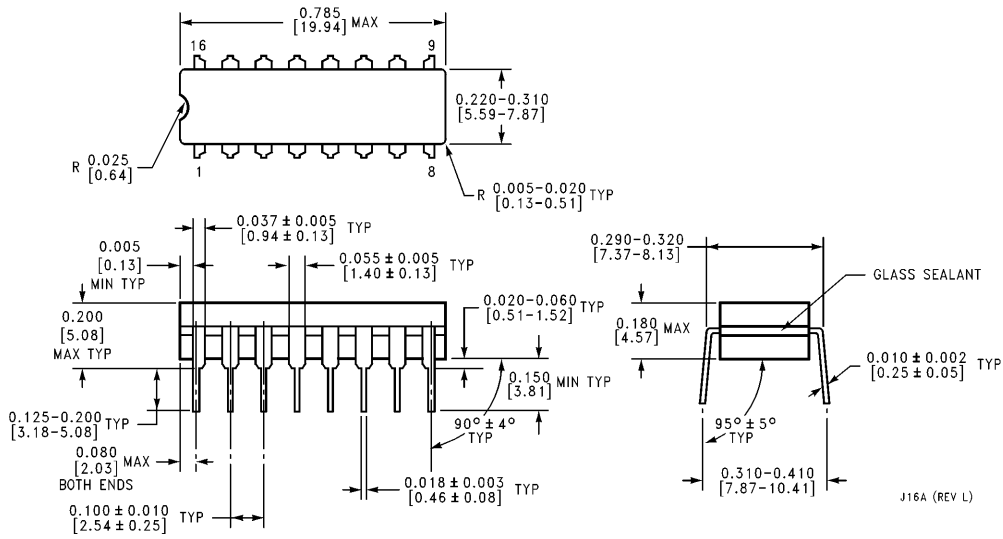

**16-Lead Ceramic Dual-In-Line Package (J)**  
**Order Number 9300DMQB**  
**NS Package Number J16A**

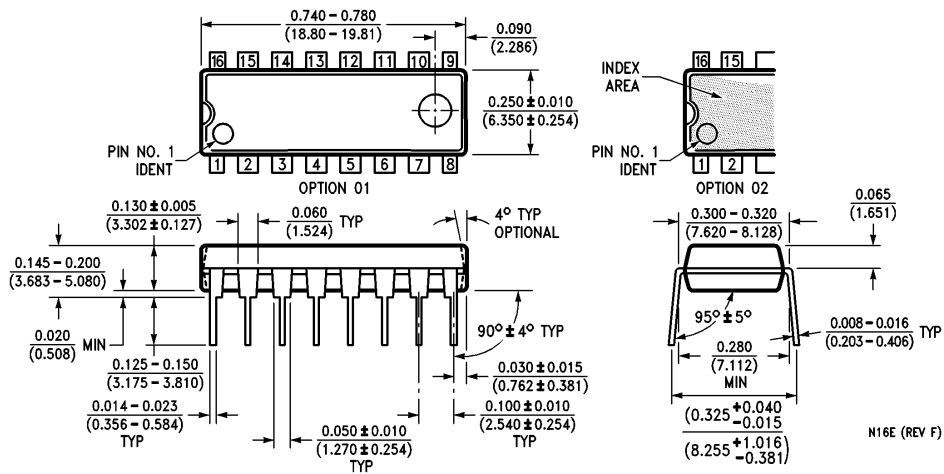

**16-Lead Molded Dual-In-Line Package (N)**  
**Order Number DM9300N**  
**NS Package Number N16E**

**Physical Dimensions** inches (millimeters) (Continued)

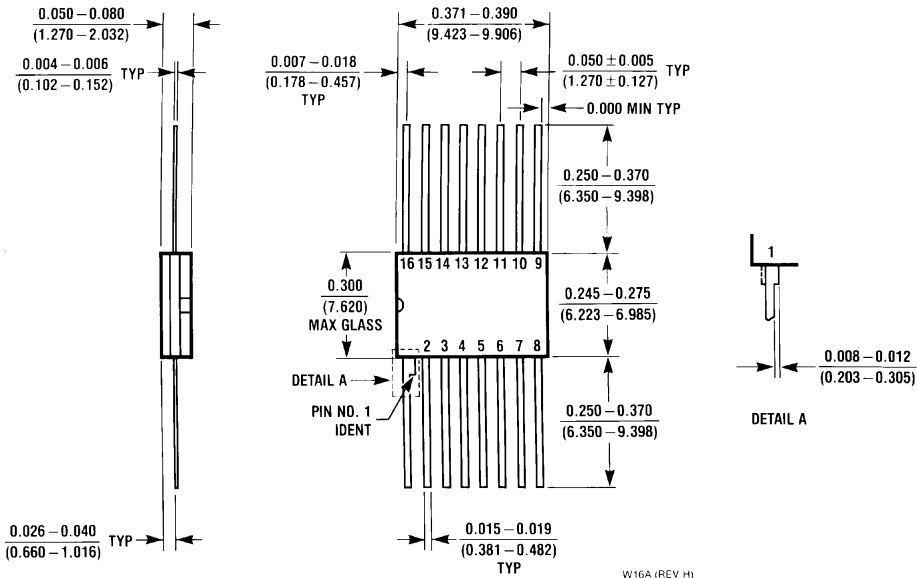

**16-Lead Ceramic Flat Package (W)**  
**Order Number 9300FMQB**  
**NS Package Number W16A**

**LIFE SUPPORT POLICY**

NATIONAL'S PRODUCTS ARE NOT AUTHORIZED FOR USE AS CRITICAL COMPONENTS IN LIFE SUPPORT DEVICES OR SYSTEMS WITHOUT THE EXPRESS WRITTEN APPROVAL OF THE PRESIDENT OF NATIONAL SEMICONDUCTOR CORPORATION. As used herein:

1. Life support devices or systems are devices or systems which, (a) are intended for surgical implant into the body, or (b) support or sustain life, and whose failure to perform, when properly used in accordance with instructions for use provided in the labeling, can be reasonably expected to result in a significant injury to the user.
2. A critical component is any component of a life support device or system whose failure to perform can be reasonably expected to cause the failure of the life support device or system, or to affect its safety or effectiveness.



**National Semiconductor Corporation**  
 1111 West Bardin Road  
 Arlington, TX 76017  
 Tel: 1(800) 272-9959  
 Fax: 1(800) 737-7018

**National Semiconductor Europe**  
 Fax: (+49) 0-180-530 85 86  
 Email: [cnjwge@tevm2.nsc.com](mailto:cnjwge@tevm2.nsc.com)  
 Deutsch Tel: (+49) 0-180-530 85 85  
 English Tel: (+49) 0-180-532 78 32  
 Français Tel: (+49) 0-180-532 93 58  
 Italiano Tel: (+49) 0-180-534 16 80

**National Semiconductor Hong Kong Ltd.**  
 13th Floor, Straight Block,  
 Ocean Centre, 5 Canton Rd.  
 Tsimshatsui, Kowloon  
 Hong Kong  
 Tel: (852) 2737-1600  
 Fax: (852) 2736-9960

**National Semiconductor Japan Ltd.**  
 Tel: 81-043-299-2309  
 Fax: 81-043-299-2408

National does not assume any responsibility for use of any circuitry described, no circuit patent licenses are implied and National reserves the right at any time without notice to change said circuitry and specifications.

# National Semiconductor was acquired by Texas Instruments.

[http://www.ti.com/corp/docs/investor\\_relations/pr\\_09\\_23\\_2011\\_national\\_semiconductor.html](http://www.ti.com/corp/docs/investor_relations/pr_09_23_2011_national_semiconductor.html)

This file is the datasheet for the following electronic components:

9300 - <http://www.ti.com/product/9300?HQS=TI-null-null-dscatalog-df-pf-null-wwe>

DM9300 - <http://www.ti.com/product/dm9300?HQS=TI-null-null-dscatalog-df-pf-null-wwe>



LittleDiode supplies new, hard to find or obsolete electronic components and semiconductors all over the world.

With over two million different components listed you are sure to find the part you need.

Feel free to visit us today at our online store:

[LittleDiode.com](http://LittleDiode.com)

Looking forward to providing you with the best possible service.