

Differential/Cascode Amplifier for Commercial and Industrial Equipment from DC to 120MHz

The CA3028A is a differential/cascode amplifier designed for use in communications and industrial equipment operating at frequencies from DC to 120MHz.

Part Number Information

PART NUMBER (BRAND)	TEMP. RANGE (°C)	PACKAGE	PKG. NO.
CA3028A	-55 to 125	8 Pin Metal Can	T8.C
CA3028AE	-55 to 125	8 Ld PDIP	E8.3
CA3028AM96 (3028A)	-55 to 125	8 Ld SOIC Tape and Reel	M8.15

Pinouts

CA3028A (PDIP, SOIC) TOP VIEW

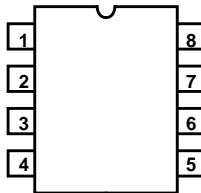

CA3028A (METAL CAN) TOP VIEW

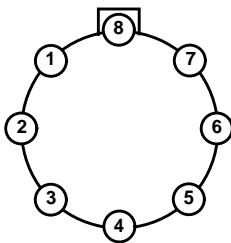

Features

- Controlled for Input Offset Voltage, Input Offset Current and Input Bias Current
- Balanced Differential Amplifier Configuration with Controlled Constant Current Source
- Single-Ended and Dual-Ended Operation

Applications

- RF and IF Amplifiers (Differential or Cascode)
- DC, Audio and Sense Amplifiers
- Converter in the Commercial FM Band
- Oscillator
- Mixer
- Limiter
- Related Literature
 - Application Note AN5337 "Application of the CA3028 Integrated Circuit Amplifier in the HF and VHF Ranges." This note covers characteristics of different operating modes, noise performance, mixer, limiter, and amplifier design considerations

Schematic Diagram

(Terminal Numbers Apply to All Packages)

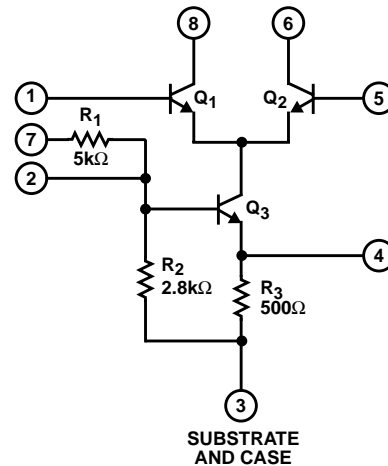

CA3028A

Operating Conditions

Temperature Range -55°C to 125°C

Thermal Information

Thermal Resistance (Typical, Note 1)	θ_{JA} (°C/W)	θ_{JC} (°C/W)
Metal Can Package	225	140
PDIP Package	155	N/A
SOIC Package	185	N/A
Maximum Junction Temperature (Metal Can Package)	175°C	
Maximum Junction Temperature (Plastic Package)	150°C	
Maximum Storage Temperature Range	-65°C to 150°C	
Maximum Lead Temperature (Soldering 10s)	300°C (SOIC - Lead Tips Only)	

CAUTION: Stresses above those listed in "Absolute Maximum Ratings" may cause permanent damage to the device. This is a stress only rating and operation of the device at these or any other conditions above those indicated in the operational sections of this specification is not implied.

NOTE:

1. θ_{JA} is measured with the component mounted on an evaluation PC board in free air.

Absolute Maximum Voltage Ratings $T_A = 25^\circ\text{C}$

The following chart gives the range of voltages which can be applied to the terminals listed horizontally with respect to the terminals listed vertically. For example, the voltage range of the horizontal Terminal 4 with respect to Terminal 2 is -1V to +5V.

TERM NO.	1	2	3	4	5	6	7	8
1		0 to -15	0 to -15	0 to -15	+5 to -5	Note 3	Note 3	+20 to 0
2			+5 to -11	+5 to -1	+15 to 0	Note 3	+15 to 0	Note 3
3 (Note 2)				+10 to 0	+15 to 0	+24 to 0	+15 to 0	+24 to 0
4					+15 to 0	Note 3	Note 3	Note 3
5						+20 to 0	Note 3	Note 3
6							Note 3	Note 3
7								Note 3
8								

Absolute Maximum Current Ratings

TERM NO.	I_{IN} mA	I_{OUT} mA
1	0.6	0.1
2	4	0.1
3	0.1	23
4	20	0.1
5	0.6	0.1
6	20	0.1
7	4	0.1
8	20	0.1

NOTES:

2. Terminal No. 3 is connected to the substrate and case.
3. Voltages are not normally applied between these terminals. Voltages appearing between these terminals will be safe, if the specified voltage limits between all other terminals are not exceeded.

Electrical Specifications $T_A = 25^\circ\text{C}$

PARAMETER	SYMBOL	TEST CONDITIONS	MIN	TYP	MAX	UNIT
DC CHARACTERISTICS						
Input Bias Current (Figures 1, 10)	I_i	$V_{CC} = 6V, V_{EE} = -6V$	-	16.6	70	μA
		$V_{CC} = 12V, V_{EE} = -12V$	-	36	106	μA
Quiescent Operating Current (Figures 1, 11, 12)	I_6, I_8	$V_{CC} = 6V, V_{EE} = -6V$	0.8	1.25	2.0	mA
		$V_{CC} = 12V, V_{EE} = -12V$	2.0	3.3	5.0	mA
AGC Bias Current (Into Constant Current Source Terminal 7) (Figures 2, 13)	I_7	$V_{CC} = 12V, V_{AGC} = 9V$	-	1.28	-	mA
		$V_{CC} = 12V, V_{AGC} = 12V$	-	1.65	-	mA
Input Current (Terminal 7)	I_7	$V_{CC} = 6V, V_{EE} = -6V$	0.5	0.85	1.0	mA
		$V_{CC} = 12V, V_{EE} = -12V$	1.0	1.65	2.1	mA
Power Dissipation (Figures 1, 14)	P_T	$V_{CC} = 6V, V_{EE} = -6V$	24	36	54	mW
		$V_{CC} = 12V, V_{EE} = -12V$	120	175	260	mW

CA3028A

Electrical Specifications $T_A = 25^\circ\text{C}$ (Continued)

PARAMETER	SYMBOL	TEST CONDITIONS	MIN	TYP	MAX	UNIT		
DYNAMIC CHARACTERISTICS								
Power Gain (Figures 3, 4, 5, 15, 17, 19)	G_P	$f = 100\text{MHz}$ $V_{CC} = 9\text{V}$	Cascode	16	20	-	dB	
			Diff. Amp.	14	17	-	dB	
			$f = 10.7\text{MHz}$ $V_{CC} = 9\text{V}$	Cascode	35	39	-	dB
				Diff. Amp.	28	32	-	dB
Noise Figure (Figures 3, 4, 5, 16, 18, 19)	NF	$f = 100\text{MHz}$, $V_{CC} = 9\text{V}$	Cascode	-	7.2	9.0	dB	
			Diff. Amp.	-	6.7	9.0	dB	
Input Admittance (Figures 20, 21)	Y_{11}	$f = 10.7\text{MHz}$, $V_{CC} = 9\text{V}$	Cascode	-	$0.6 + j1.6$	-	mS	
			Diff. Amp.	-	$0.5 + j0.5$	-	mS	
Reverse Transfer Admittance (Figures 22, 23)	Y_{12}	$f = 10.7\text{MHz}$, $V_{CC} = 9\text{V}$	Cascode	-	$0.0003 - j0$	-	mS	
			Diff. Amp.	-	$0.01 - j0.0002$	-	mS	
Forward Transfer Admittance (Figures 24, 25)	Y_{21}	$f = 10.7\text{MHz}$, $V_{CC} = 9\text{V}$	Cascode	-	$99 - j18$	-	mS	
			Diff. Amp.	-	$-37 + j0.5$	-	mS	
Output Admittance (Figures 26, 27)	Y_{22}	$f = 10.7\text{MHz}$, $V_{CC} = 9\text{V}$	Cascode	-	$0 + j0.08$	-	mS	
			Diff. Amp.	-	$0.04 + j0.23$	-	mS	
Output Power (Untuned) (Figures 6, 28)	P_O	$f = 10.7\text{MHz}$, $V_{CC} = 9\text{V}$	Diff. Amp., 50Ω Input-Output	-	5.7	-	μW	
AGC Range (Maximum Power Gain to Full Cutoff) (Figures 7, 29)	AGC	$f = 10.7\text{MHz}$, $V_{CC} = 9\text{V}$	Diff. Amp.	-	62	-	dB	
Voltage Gain (Figures 8, 9, 30, 31)	A	$f = 10.7\text{MHz}$, $V_{CC} = 9\text{V}$, $R_L = 1\text{k}\Omega$	Cascode	-	40	-	dB	
			Diff. Amp.	-	30	-	dB	
Peak-to-Peak Output Current	I_{P-P}	$f = 10.7\text{MHz}$, $e_{IN} = 400\text{mV}$, Diff. Amp.	$V_{CC} = 9\text{V}$	2.0	4.0	7.0	mA	
			$V_{CC} = 12\text{V}$	3.5	6.0	10	mA	

Test Circuits

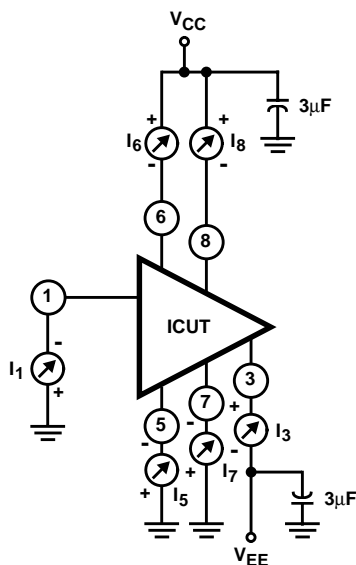

NOTE: Power Dissipation = $I_3 V_{EE} + (I_6 + I_8) V_{CC}$.

FIGURE 1. INPUT OFFSET CURRENT, INPUT BIAS CURRENT, POWER DISSIPATION, AND QUIESCENT OPERATING CURRENT TEST CIRCUIT

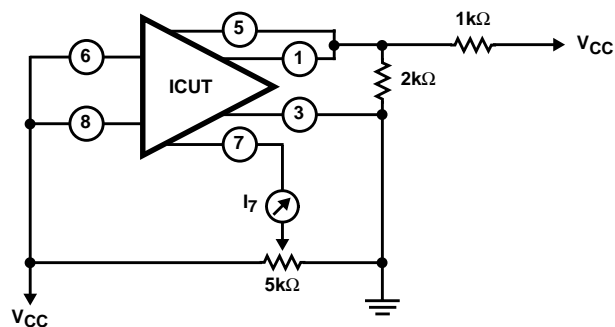
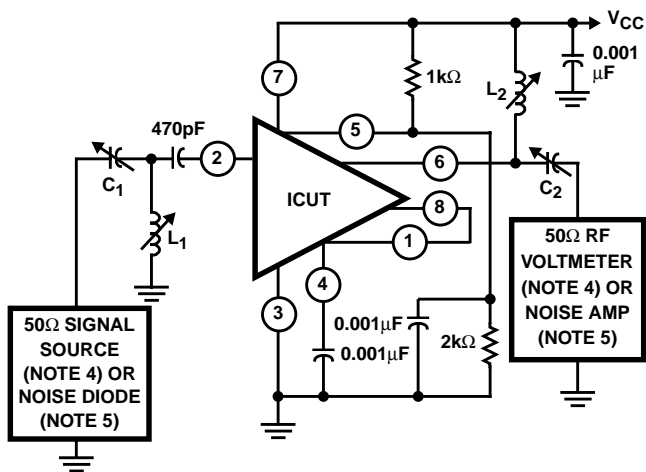

FIGURE 2. AGC BIAS CURRENT TEST CIRCUIT (DIFFERENTIAL AMPLIFIER CONFIGURATION)



f (MHz)	C ₁ (pF)	C ₂ (pF)	L ₁ (µH)	L ₂ (µH)
10.7	20 - 60	20 - 60	3 - 5	3 - 5
100	3 - 30	3 - 30	0.1 - 0.25	0.15 - 0.3

NOTES:

- 4. For Power Gain Test.
- 5. For Noise Figure Test.

FIGURE 3. POWER GAIN AND NOISE FIGURE TEST CIRCUIT (CASCODE CONFIGURATION)

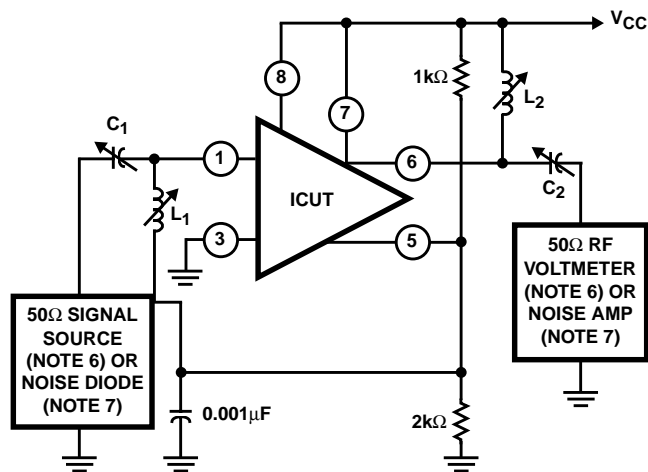

f (MHz)	C ₁ (pF)	C ₂ (pF)	L ₁ (µH)	L ₂ (µH)
10.7	30 - 60	20 - 50	3 - 6	3 - 6
100	2 - 15	2 - 15	0.2 - 0.5	0.2 - 0.5

NOTES:

- 6. For Power Gain Test.
- 7. For Noise Figure Test.

FIGURE 4. POWER GAIN AND NOISE FIGURE TEST CIRCUIT (DIFFERENTIAL AMPLIFIER CONFIGURATION AND TERMINAL 7 CONNECTED TO V_{CC})

Test Circuits (Continued)

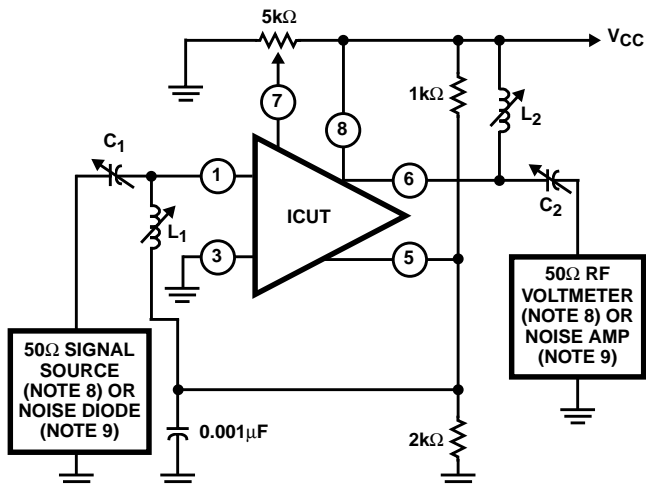

f (MHz)	C ₁ (pF)	C ₂ (pF)	L ₁ (μH)	L ₂ (μH)
10.7	30 - 60	20 - 50	3 - 6	3 - 6
100	2 - 15	2 - 15	0.2 - 0.5	0.2 - 0.5

NOTES:

- 8. For Power Gain Test.
- 9. For Noise Figure Test.

FIGURE 5. POWER GAIN AND NOISE FIGURE TEST CIRCUIT (DIFFERENTIAL AMPLIFIER CONFIGURATION)

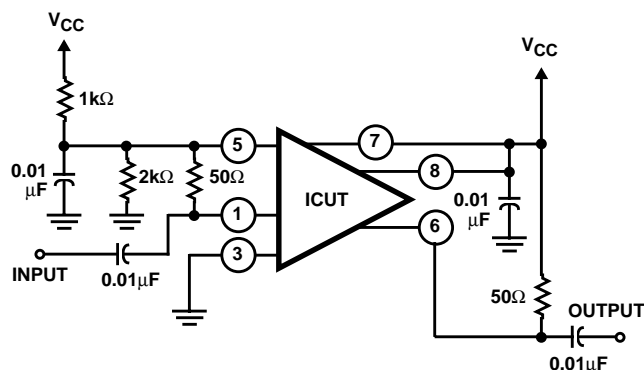
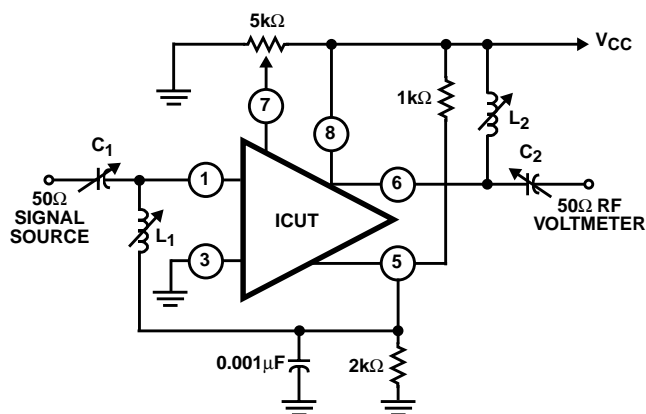

FIGURE 6. OUTPUT POWER TEST CIRCUIT



f (MHz)	C ₁ (pF)	C ₂ (pF)	L ₁ (μH)	L ₂ (μH)
10.7	30 - 60	20 - 50	3 - 6	3 - 6
100	2 - 15	2 - 15	0.2 - 0.5	0.2 - 0.5

FIGURE 7. AGC RANGE TEST CIRCUIT (DIFFERENTIAL AMPLIFIER)

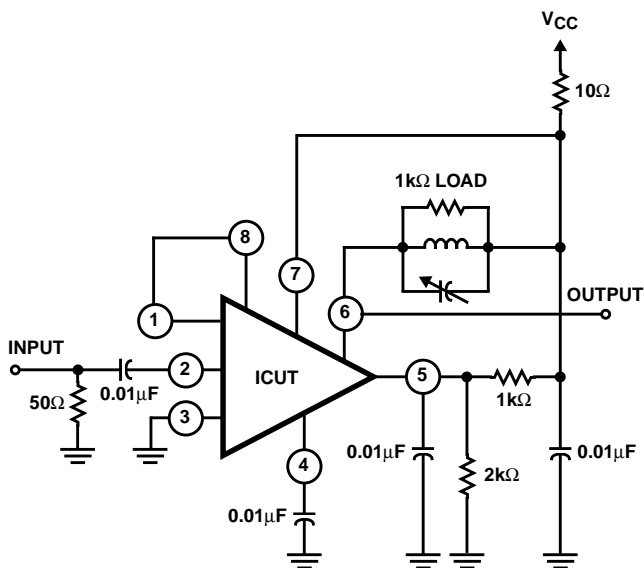

FIGURE 8. TRANSFER CHARACTERISTIC (VOLTAGE GAIN) TEST CIRCUIT (10.7MHz) CASCODE CONFIGURATION

Test Circuits (Continued)

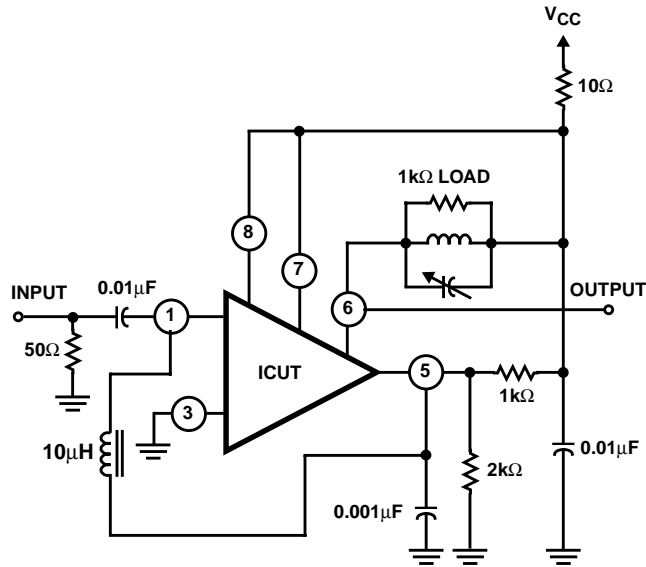

FIGURE 9. TRANSFER CHARACTERISTIC (VOLTAGE GAIN) TEST CIRCUIT (10.7MHz) DIFFERENTIAL AMPLIFIER CONFIGURATION

Typical Performance Curves

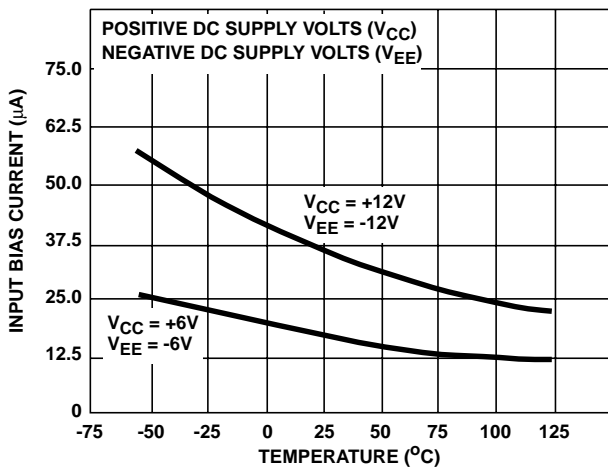

FIGURE 10. INPUT BIAS CURRENT vs TEMPERATURE

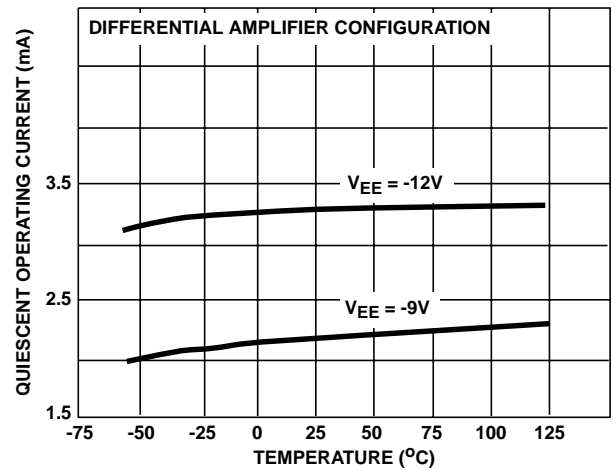

FIGURE 11. QUIESCENT OPERATING CURRENT vs TEMPERATURE

Typical Performance Curves (Continued)

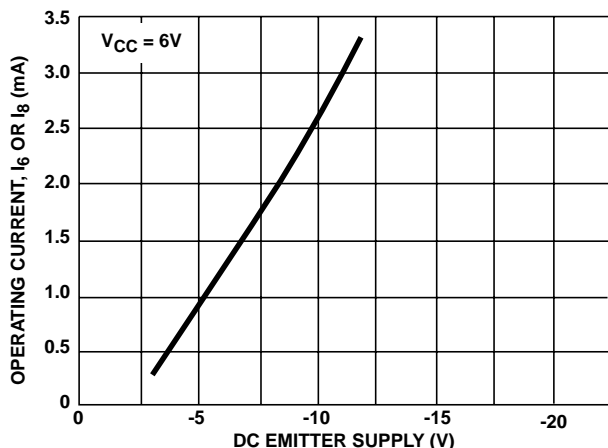

FIGURE 12. OPERATING CURRENT vs V_{EE} VOLTAGE

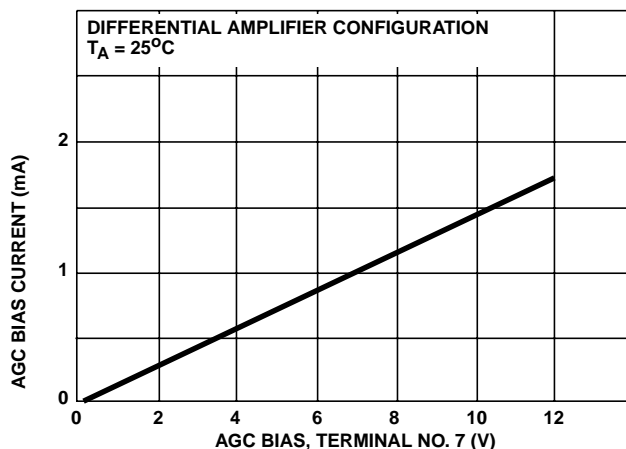

FIGURE 13. AGC BIAS CURRENT vs BIAS VOLTAGE (TERMINAL 7)

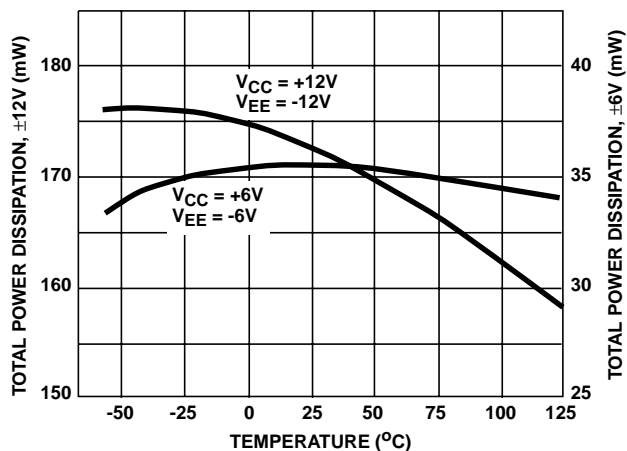

FIGURE 14. POWER DISSIPATION vs TEMPERATURE

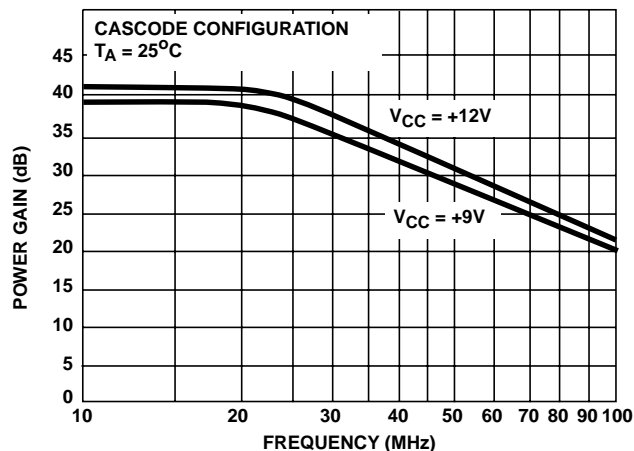

FIGURE 15. POWER GAIN vs FREQUENCY (CASCODE CONFIGURATION)

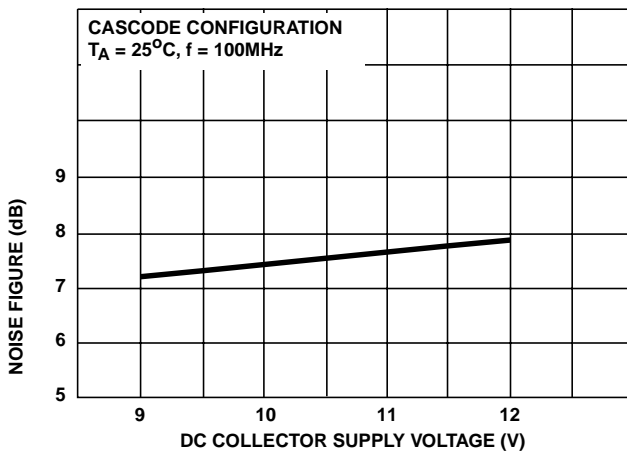

FIGURE 16. 100MHz NOISE FIGURE vs COLLECTOR SUPPLY VOLTAGE (CASCODE CONFIGURATION)

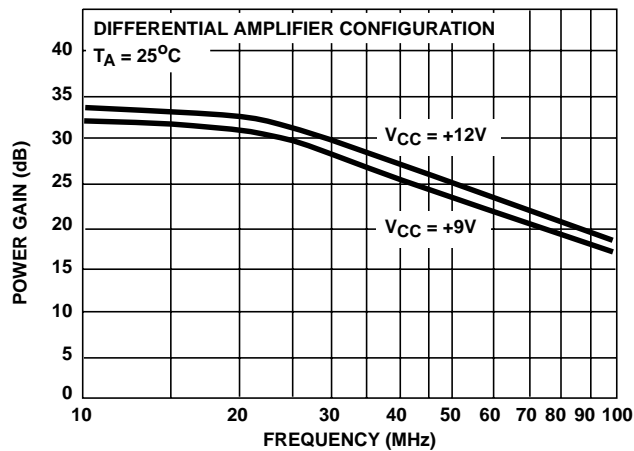

FIGURE 17. POWER GAIN vs FREQUENCY (DIFFERENTIAL AMPLIFIER CONFIGURATION)

Typical Performance Curves (Continued)

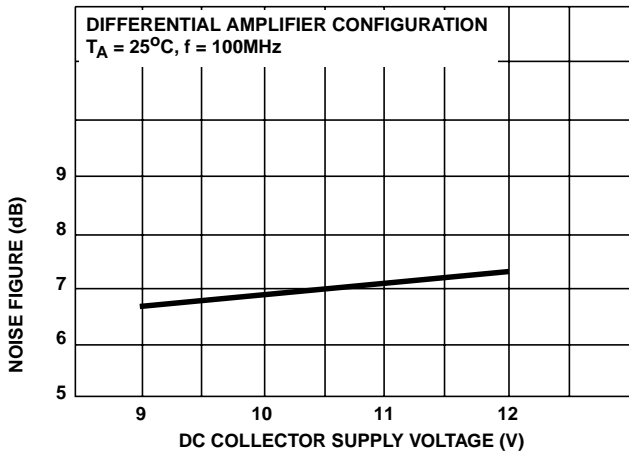

FIGURE 18. 100MHz NOISE FIGURE vs COLLECTOR SUPPLY VOLTAGE (DIFFERENTIAL AMPLIFIER CONFIGURATION)

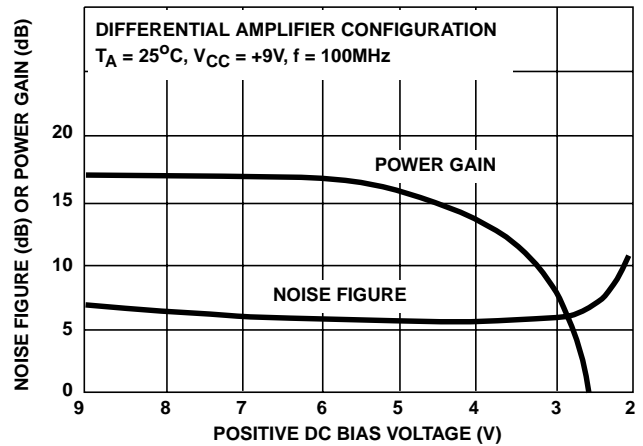

FIGURE 19. 100MHz NOISE FIGURE AND POWER GAIN vs BASE-TO-EMITTER BIAS VOLTAGE (TERMINAL 7)

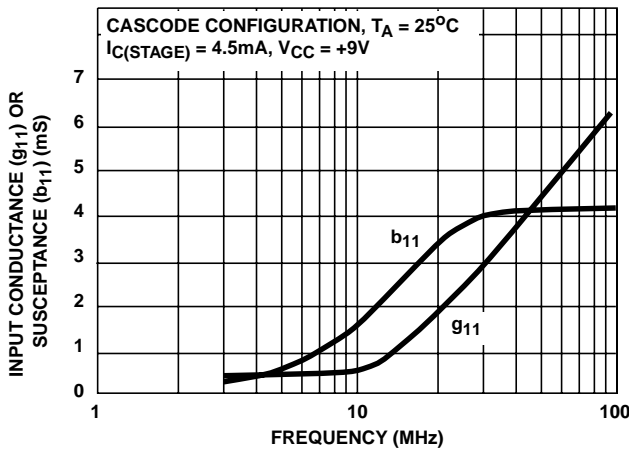

FIGURE 20. INPUT ADMITTANCE (Y_{11}) vs FREQUENCY (CASCODE CONFIGURATION)

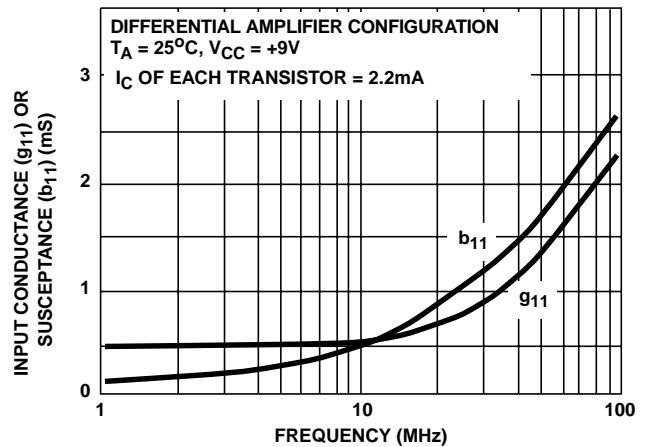

FIGURE 21. INPUT ADMITTANCE (Y_{11}) vs FREQUENCY (DIFFERENTIAL AMPLIFIER CONFIGURATION)

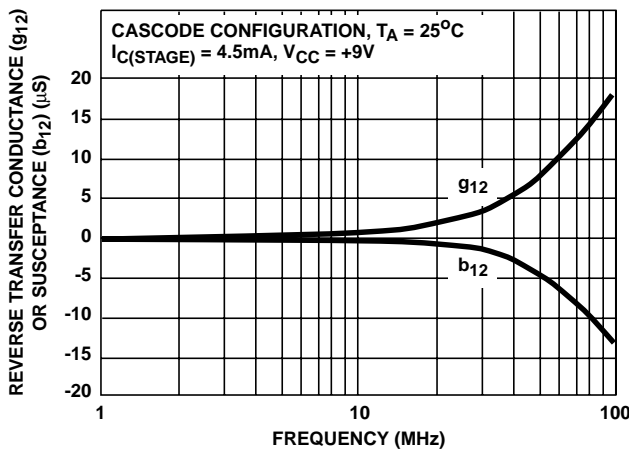

FIGURE 22. REVERSE TRANSADMITTANCE (Y_{12}) vs FREQUENCY (CASCODE CONFIGURATION)

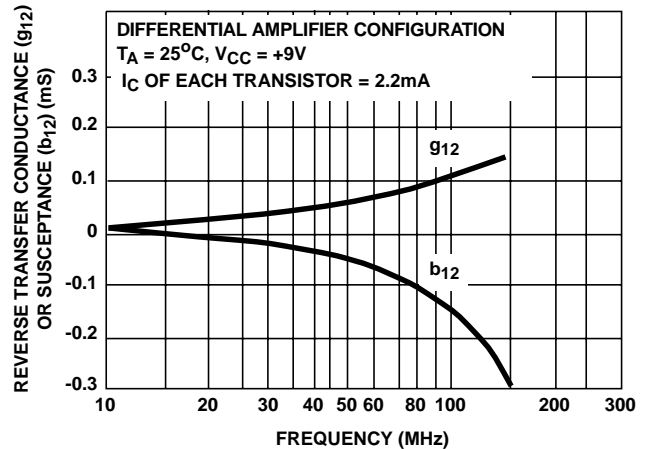

FIGURE 23. REVERSE TRANSADMITTANCE (Y_{12}) vs FREQUENCY (DIFFERENTIAL AMPLIFIER CONFIGURATION)

Typical Performance Curves (Continued)

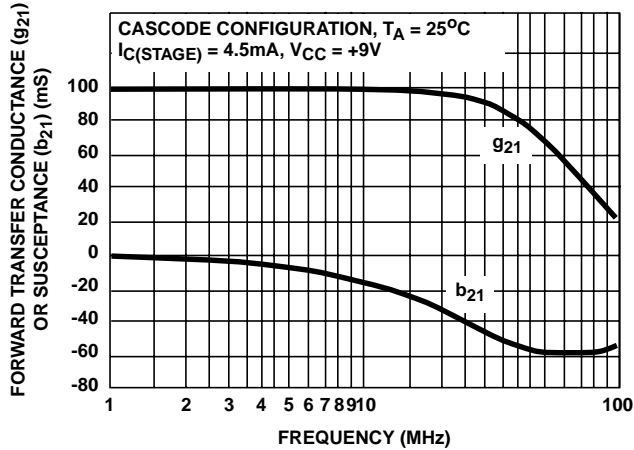

FIGURE 24. FORWARD TRANSADMITTANCE (Y_{21}) vs FREQUENCY (CASCODE CONFIGURATION)

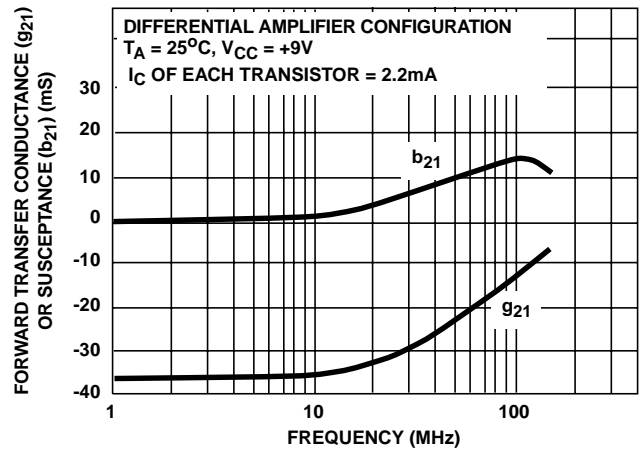

FIGURE 25. FORWARD TRANSADMITTANCE (Y_{21}) vs FREQUENCY (DIFFERENTIAL AMPLIFIER CONFIGURATION)

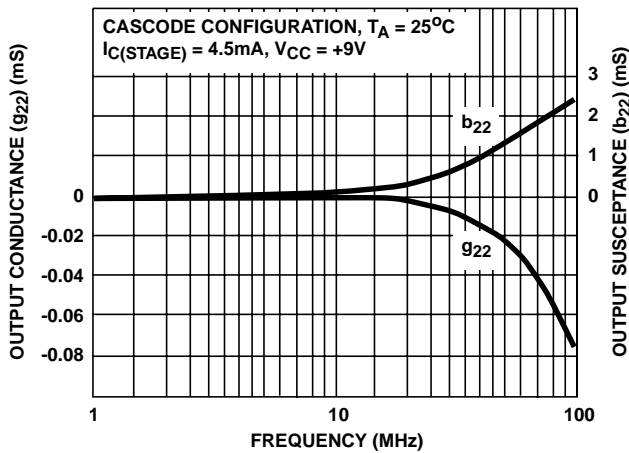

FIGURE 26. OUTPUT ADMITTANCE (Y_{22}) vs FREQUENCY (CASCODE CONFIGURATION)

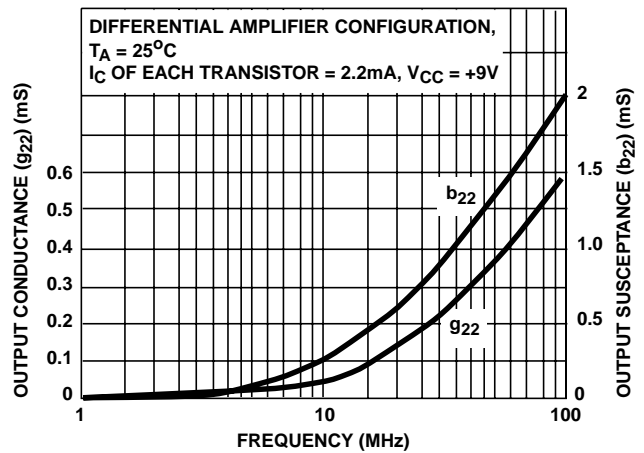

FIGURE 27. OUTPUT ADMITTANCE (Y_{22}) vs FREQUENCY (DIFFERENTIAL AMPLIFIER CONFIGURATION)

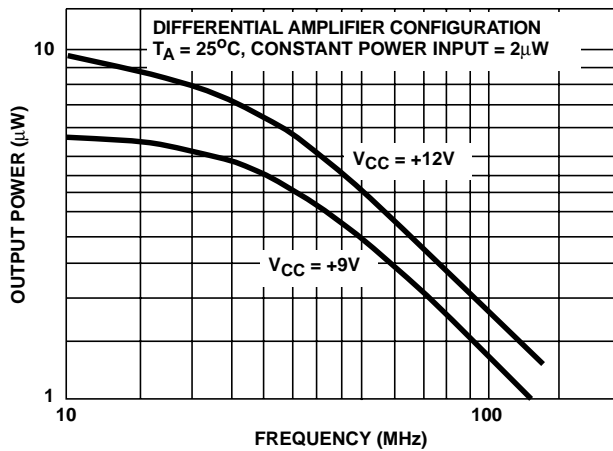

FIGURE 28. OUTPUT POWER vs FREQUENCY - 50 Ω INPUT AND 50 Ω OUTPUT (DIFFERENTIAL AMPLIFIER CONFIGURATION)

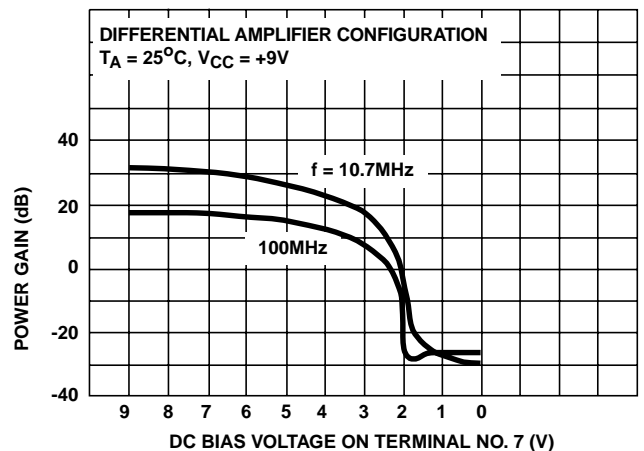

FIGURE 29. AGC CHARACTERISTICS

Typical Performance Curves (Continued)

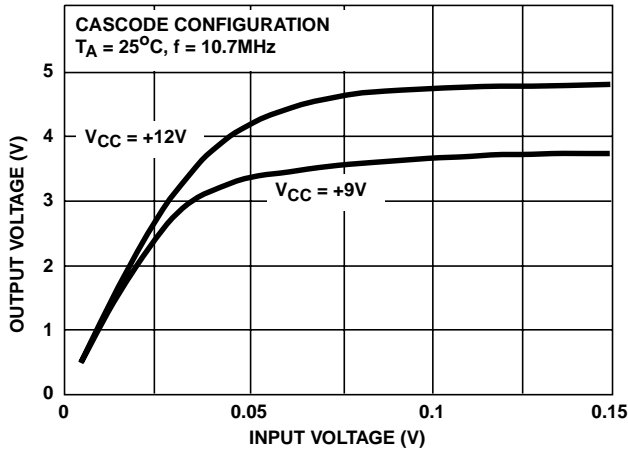

FIGURE 30. TRANSFER CHARACTERISTICS (CASCODE CONFIGURATION)

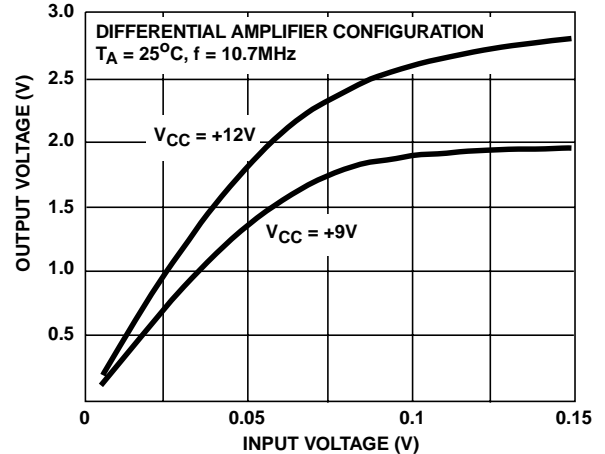

FIGURE 31. TRANSFER CHARACTERISTICS (DIFFERENTIAL AMPLIFIER CONFIGURATION)

Glossary of Terms

AGC Bias Current - The current drawn by the device from the AGC voltage source, at maximum AGC voltage.

AGC Range - The total change in voltage gain (from maximum gain to complete cutoff) which may be achieved by application of the specified range of dc voltage to the AGC input terminal of the device.

Common Mode Rejection Ratio - The ratio of the full differential voltage gain to the common mode voltage gain.

Power Dissipation - The total power drain of the device with no signal applied and no external load current.

Input Bias Current - The average value (one half the sum) of the currents at the two input terminals when the quiescent operating voltages at the two output terminals are equal.

Input Offset Current - The difference in the currents at the two input terminals when the quiescent operating voltages at the two output terminals are equal.

Input Offset Voltage - The difference in the DC voltages which must be applied to the input terminals to obtain equal quiescent operating voltages (zero output offset voltage) at the output terminals.

Noise Figure - The ratio of the total noise power of the device and a resistive signal source to the noise power of the signal source alone, the signal source representing a generator of zero impedance in series with the source resistance.

Power Gain - The ratio of the signal power developed at the output of the device to the signal power applied to the input, expressed in dB.

Quiescent Operating Current - The average (DC) value of the current in either output terminal.

Voltage Gain - The ratio of the change in output voltage at either output terminal with respect to ground, to a change in input voltage at either input terminal with respect to ground, with the other input terminal at AC ground.

This datasheet has been downloaded from:

www.DatasheetCatalog.com

Datasheets for electronic components.



LittleDiode supplies new, hard to find or obsolete electronic components and semiconductors all over the world.

With over two million different components listed you are sure to find the part you need.

Feel free to visit us today at our online store:

LittleDiode.com

Looking forward to providing you with the best possible service.