



Integrated Device Technology, Inc.

FAST CMOS SYNCHRONOUS PRESETTABLE BINARY COUNTERS

IDT54/74FCT161T/AT/CT
IDT54/74FCT163T/AT/CT

FEATURES:

- Std., A and C speed grades
- Low input and output leakage $\leq 1\mu\text{A}$ (max.)
- CMOS power levels
- True TTL input and output compatibility
 - $V_{OH} = 3.3\text{V}$ (typ.)
 - $V_{OL} = 0.3\text{V}$ (typ.)
- High drive outputs (-15mA I_{OH} , 48mA I_{OL})
- Meets or exceeds JEDEC standard 18 specifications
- Product available in Radiation Tolerant and Radiation Enhanced versions
- Military product compliant to MIL-STD-883, Class B and DESC listed (dual marked)
- Available in DIP, SOIC, QSOP, CERPACK and LCC packages

DESCRIPTION:

The IDT54/74FCT161T/163T, IDT54/74FCT161AT/163AT and IDT54/74FCT161CT/163CT are high-speed synchronous modulo-16 binary counters built using an advanced dual metal CMOS technology. They are synchronously presettable for application in programmable dividers and have two types of count enable inputs plus a terminal count output for versatility in forming synchronous multi-stage counters. The IDT54/74FCT161T/AT/CT have asynchronous Master Reset inputs that override all other inputs and force the outputs LOW. The IDT54/74FCT163T/AT/CT have Synchronous Reset inputs that override counting and parallel loading and allow the outputs to be simultaneously reset on the rising edge of the clock.

FUNCTIONAL BLOCK DIAGRAMS

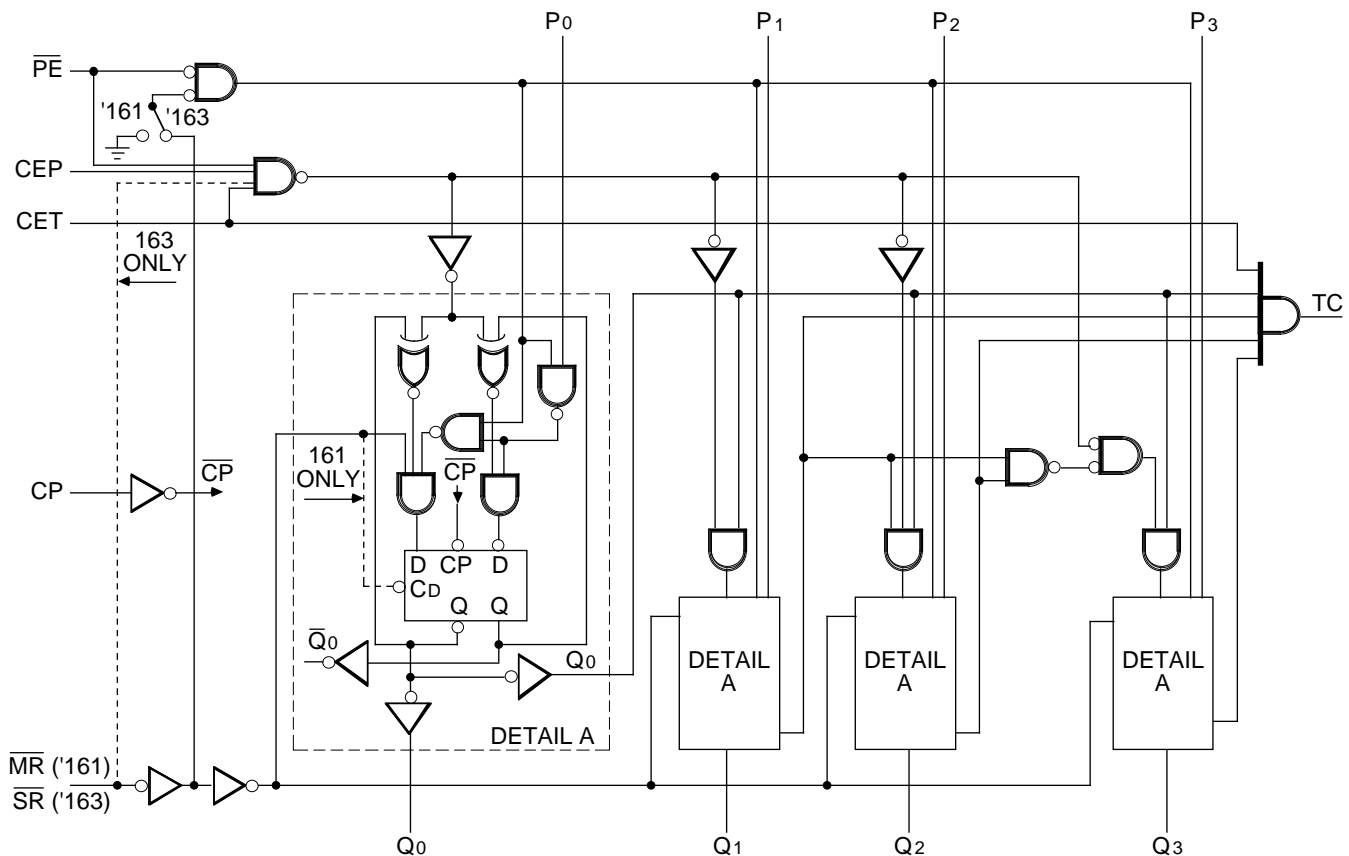

2611 drw 01

The IDT logo is a registered trademark of Integrated Device Technology, Inc.

MILITARY AND COMMERCIAL TEMPERATURE RANGES

OCTOBER 1994

PIN CONFIGURATIONS

IDT54/74FCT861 10-BIT TRANSCEIVERS

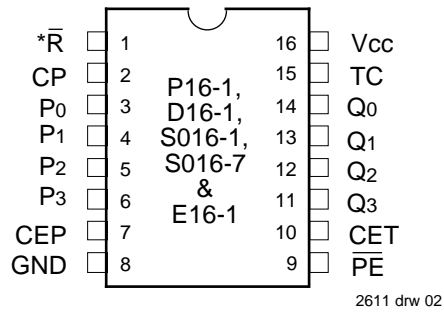

DIP/SOIC/QSOP/CERPACK
TOP VIEW

*MR for '161
*SR for '163

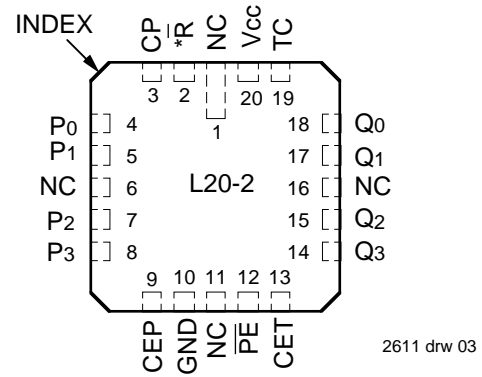

LCC
TOP VIEW

PIN DESCRIPTION

Pin Names	Description
CEP	Count Enable Parallel Input
CET	Count Enable Trickle Input
CP	Clock Pulse Input (Active Rising Edge)
MR ('161)	Asynchronous Master Reset Input (Active LOW)
SR ('163)	Synchronous Reset Input (Active LOW)
P0-3	Parallel Data Inputs
PE	Parallel Enable Input (Active LOW)
Q0-3	Flip-Flop Outputs
TC	Terminal Count Output

2611 tbl 01

FUNCTION TABLE⁽²⁾

SR ⁽¹⁾	PE	CET	CEP	Action on the Rising Clock Edge(s)
L	X	X	X	Reset (Clear)
H	L	X	X	Load (P _n →Q _n)
H	H	H	H	Count (Increment)
H	H	L	X	No Change (Hold)
H	H	X	L	No Change (Hold)

NOTES:

- 163 only.
- H = HIGH Voltage Level, L = LOW Voltage Level, X = Don't Care.

2611 tbl 02

ABSOLUTE MAXIMUM RATINGS⁽¹⁾

Symbol	Rating	Commercial	Military	Unit
VTERM ⁽²⁾	Terminal Voltage with Respect to GND	-0.5 to +7.0	-0.5 to +7.0	V
VTERM ⁽³⁾	Terminal Voltage with Respect to GND	-0.5 to Vcc +0.5	-0.5 to Vcc +0.5	V
TA	Operating Temperature	0 to +70	-55 to +125	°C
TBIAS	Temperature Under Bias	-55 to +125	-65 to +135	°C
TSTG	Storage Temperature	-55 to +125	-65 to +150	°C
PT	Power Dissipation	0.5	0.5	W
IOUT	DC Output Current	-60 to +120	-60 to +120	mA

NOTES:

2611 lmk 03

- Stresses greater than those listed under ABSOLUTE MAXIMUM RATINGS may cause permanent damage to the device. This is a stress rating only and functional operation of the device at these or any other conditions above those indicated in the operational sections of this specification is not implied. Exposure to absolute maximum rating conditions for extended periods may affect reliability. No terminal voltage may exceed Vcc by +0.5V unless otherwise noted.
- Input and Vcc terminals only.
- Outputs and I/O terminals only.

CAPACITANCE (TA = +25°C, f = 1.0MHz)

Symbol	Parameter ⁽¹⁾	Conditions	Typ.	Max.	Unit
CIN	Input Capacitance	VIN = 0V	6	10	pF
COUT	Output Capacitance	VOUT = 0V	8	12	pF

NOTE:

- This parameter is measured at characterization but not tested.

2611 lmk 04

DC ELECTRICAL CHARACTERISTICS OVER OPERATING RANGE

Following Conditions Apply Unless Otherwise Specified:

Commercial: $T_A = 0^{\circ}\text{C}$ to $+70^{\circ}\text{C}$, $V_{CC} = 5.0\text{V} \pm 5\%$; Military: $T_A = -55^{\circ}\text{C}$ to $+125^{\circ}\text{C}$, $V_{CC} = 5.0\text{V} \pm 10\%$

Symbol	Parameter	Test Conditions ⁽¹⁾		Min.	Typ. ⁽²⁾	Max.	Unit	
V_{IH}	Input HIGH Level	Guaranteed Logic HIGH Level		COM'L ⁽⁵⁾	2.0V	—	—	V
				MIL	2.7V	—	—	V
V_{IL}	Input LOW Level	Guaranteed Logic LOW Level		—	—	0.8	V	
I_{IH}	Input HIGH Current ⁽⁴⁾	$V_{CC} = \text{Max.}$	$V_I = 2.7\text{V}$	—	—	± 1	μA	
I_{IL}	Input LOW Current ⁽⁴⁾	$V_{CC} = \text{Max.}$	$V_I = 0.5\text{V}$	—	—	± 1	μA	
I_I	Input HIGH Current ⁽⁴⁾	$V_{CC} = \text{Max.}, V_I = V_{CC} (\text{Max.})$		—	—	± 1	μA	
V_{IK}	Clamp Diode Voltage	$V_{CC} = \text{Min.}, I_N = -18\text{mA}$		—	-0.7	-1.2	V	
I_{OS}	Short Circuit Current	$V_{CC} = \text{Max.}^{(3)}, V_O = \text{GND}$		-60	-120	-225	mA	
V_{OH}	Output HIGH Voltage	$V_{CC} = \text{Min.}$ $V_{IN} = V_{IH}$ or V_{IL}		$I_{OH} = -6\text{mA MIL.}$ $I_{OH} = -8\text{mA COM'L.}$	2.4	3.3	—	V
				$I_{OH} = -12\text{mA MIL.}$ $I_{OH} = -15\text{mA COM'L.}$	2.0	3.0	—	V
V_{OL}	Output LOW Voltage	$V_{CC} = \text{Min.}$ $V_{IN} = V_{IH}$ or V_{IL}	$I_{OL} = 32\text{mA MIL.}$ $I_{OL} = 48\text{mA COM'L.}$	—	0.3	0.5	V	
V_H	Input Hysteresis	—		—	200	—	mV	
I_{CC}	Quiescent Power Supply Current	$V_{CC} = \text{Max.}$ $V_{IN} = \text{GND}$ or V_{CC}		—	0.01	1	mA	

NOTES:

- For conditions shown as Max. or Min., use appropriate value specified under Electrical Characteristics for the applicable device type.
- Typical values are at $V_{CC} = 5.0\text{V}$, $+25^{\circ}\text{C}$ ambient.
- Not more than one output should be shorted at one time. Duration of the short circuit test should not exceed one second.
- The test limit for this parameter is $\pm 5\mu\text{A}$ at $T_A = -55^{\circ}\text{C}$.
- Clock pin requires a minimum V_{IH} of 2.5V.

2611 tbl 05

POWER SUPPLY CHARACTERISTICS

Symbol	Parameter	Test Conditions ⁽¹⁾		Min.	Typ. ⁽²⁾	Max.	Unit
ΔI_{CC}	Quiescent Power Supply Current TTL Inputs HIGH	$V_{CC} = \text{Max.}$ $V_{IN} = 3.4V^{(3)}$		—	0.5	2.0	mA
I_{CCD}	Dynamic Power Supply Current ⁽⁴⁾	$V_{CC} = \text{Max.}$, Outputs Open Load Mode $\overline{CEP} = \overline{CET} = \overline{PE} = \text{GND}$ \overline{MR} or $\overline{SR} = V_{CC}$ One Input Toggling 50% Duty Cycle	$V_{IN} = V_{CC}$ $V_{IN} = \text{GND}$	—	0.15	0.25	mA/ MHz
I_C	Total Power Supply Current ⁽⁶⁾	$V_{CC} = \text{Max.}$, Outputs Open Load Mode $f_{CP} = 10\text{MHz}$ 50% Duty Cycle $\overline{CEP} = \overline{CET} = \overline{PE} = \text{GND}$ \overline{MR} or $\overline{SR} = V_{CC}$ One Bit Toggling at $f_i = 5\text{MHz}$ 50% Duty Cycle	$V_{IN} = V_{CC}$ $V_{IN} = \text{GND}$	—	1.5	3.5	mA
			$V_{IN} = 3.4V$ $V_{IN} = \text{GND}$	—	2.0	5.5	
		$V_{CC} = \text{Max.}$, Outputs Open Load Mode $f_{CP} = 10\text{MHz}$ 50% Duty Cycle $\overline{CEP} = \overline{CET} = \overline{PE} = \text{GND}$ \overline{MR} or $\overline{SR} = V_{CC}$ Four Bits Toggling at $f_i = 5\text{MHz}$ 50% Duty Cycle	$V_{IN} = V_{CC}$ $V_{IN} = \text{GND}$	—	3.8	7.3 ⁽⁵⁾	
			$V_{IN} = 3.4V$ $V_{IN} = \text{GND}$	—	5.0	12.3 ⁽⁵⁾	

NOTES:

2611 tbl 06

- For conditions shown as Max. or Min., use appropriate value specified under Electrical Characteristics for the applicable device type.
- Typical values are at $V_{CC} = 5.0V$, $+25^\circ\text{C}$ ambient.
- Per TTL driven input ($V_{IN} = 3.4V$). All other inputs at V_{CC} or GND .
- This parameter is not directly testable, but is derived for use in Total Power Supply Calculations.
- Values for these conditions are examples of the I_C formula. These limits are guaranteed but not tested.
- $I_C = I_{\text{QUIESCENT}} + I_{\text{INPUTS}} + I_{\text{DYNAMIC}}$
 $I_C = I_{CC} + \Delta I_{CC} D_H N_T + I_{CCD} (f_{CP}/2 + f_i N_i)$
 I_{CC} = Quiescent Current
 ΔI_{CC} = Power Supply Current for a TTL High Input ($V_{IN} = 3.4V$)
 D_H = Duty Cycle for TTL Inputs High
 N_T = Number of TTL Inputs at D_H
 I_{CCD} = Dynamic Current Caused by an Input Transition Pair (HLH or LHL)
 f_{CP} = Clock Frequency for Register Devices (Zero for Non-Register Devices)
 f_i = Input Frequency
 N_i = Number of Inputs at f_i
 All currents are in milliamps and all frequencies are in megahertz.

SWITCHING CHARACTERISTICS OVER OPERATING RANGE

Symbol	Parameter	Condition ⁽¹⁾	IDT54/74FCT161T IDT54/74FCT163T		IDT54/74FCT161AT IDT54/74FCT163AT		IDT54/74FCT161CT IDT54/74FCT163CT						Unit		
			Com'l.		Mil.		Com'l.		Mil.		Com'l.			Mil.	
			Min. ⁽²⁾	Max.	Min. ⁽²⁾	Max.	Min. ⁽²⁾	Max.	Min. ⁽²⁾	Max.	Min. ⁽²⁾	Max.		Min. ⁽²⁾	Max.
tPLH tPHL	Propagation Delay CP to Q _n (PE Input HIGH)	CL = 50pF RL = 500Ω	2.0	11.0	2.0	11.5	2.0	7.2	2.0	7.5	2.0	5.8	2.0	6.3	ns
tPLH tPHL	Propagation Delay CP to Q _n (PE Input LOW)		2.0	9.5	2.0	10.0	2.0	6.2	2.0	6.5	2.0	5.8	2.0	6.3	ns
tPLH tPHL	Propagation Delay CP to TC		2.0	15.0	2.0	16.5	2.0	9.8	2.0	10.8	2.0	7.4	2.0	8.3	ns
tPLH tPHL	Propagation Delay CET to TC		1.5	8.5	1.5	9.0	1.5	5.5	1.5	5.9	1.5	5.2	1.5	5.6	ns
tPHL	Propagation Delay MR to Q _n ('161)		2.0	13.0	2.0	14.0	2.0	8.5	2.0	9.1	2.0	6.0	2.0	6.6	ns
tPHL	Propagation Delay MR to TC ('161)		2.0	11.5	2.0	12.5	2.0	7.5	2.0	8.2	2.0	7.0	2.0	7.7	ns
tsu	Set-up Time, HIGH or LOW P _n to CP		5.0	—	5.5	—	4.0	—	4.5	—	4.0	—	4.5	—	ns
th	Hold Time, HIGH or LOW P _n to CP		1.5	—	2.0	—	1.5	—	2.0	—	1.5	—	2.0	—	ns
tsu	Set-up Time, HIGH or LOW PE or SR to CP		11.5	—	13.5	—	9.5	—	11.5	—	9.5	—	11.5	—	ns
th	Hold Time, HIGH or LOW PE or SR to CP		1.5	—	1.5	—	1.5	—	1.5	—	1.5	—	1.5	—	ns
tsu	Set-up Time, HIGH or LOW CEP or CET to CP		11.5	—	13.0	—	9.5	—	11.0	—	9.5	—	11.0	—	ns
th	Hold Time, HIGH or LOW CEP or CET to CP		0	—	0	—	0	—	0	—	0	—	0	—	ns
tw	Clock Pulse Width (Load) HIGH or LOW		5.0	—	5.0	—	4.0 ⁽³⁾	—	4.0 ⁽³⁾	—	4.0 ⁽³⁾	—	4.0 ⁽³⁾	—	ns
tw	Clock Pulse Width (Count) HIGH or LOW		7.0	—	8.0	—	6.0	—	7.0	—	6.0	—	7.0	—	ns
tw	MR Pulse Width, LOW ('161)	5.0	—	5.0	—	4.0 ⁽³⁾	—	4.0 ⁽³⁾	—	4.0 ⁽³⁾	—	4.0 ⁽³⁾	—	ns	
tREM	Recovery Time MR to CP ('161)	6.0	—	6.0	—	5.0	—	5.0	—	5.0	—	5.0	—	ns	

NOTES:

1. See test circuits and waveforms.
2. Minimum limits are guaranteed but not tested on Propagation Delays.
3. This limit is guaranteed but not tested.

2611 tbl 07

TEST CIRCUITS AND WAVEFORMS

TEST CIRCUITS FOR ALL OUTPUTS

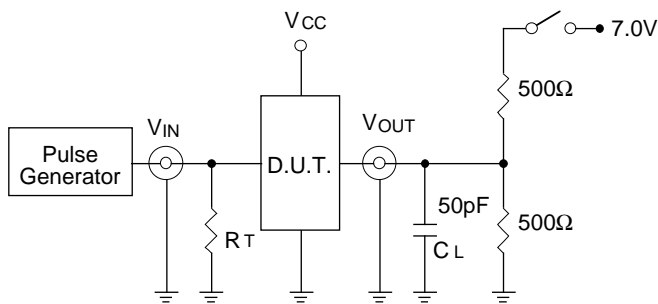

2611 drw 04

SWITCH POSITION

Test	Switch
Open Drain Disable Low Enable Low	Closed
All Other Tests	Open

DEFINITIONS:

C_L = Load capacitance: includes jig and probe capacitance.
 R_T = Termination resistance: should be equal to Z_{OUT} of the Pulse Generator.

2611 Ink 08

SET-UP, HOLD AND RELEASE TIMES

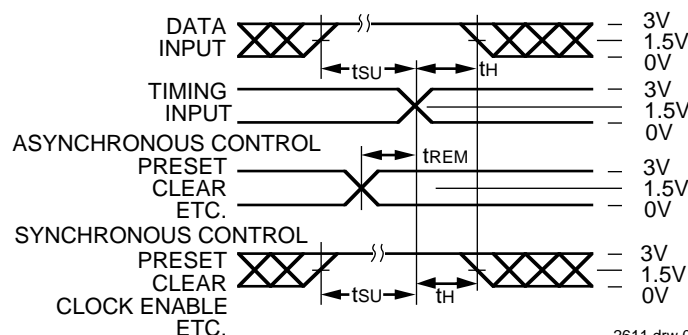

2611 drw 05

PULSE WIDTH

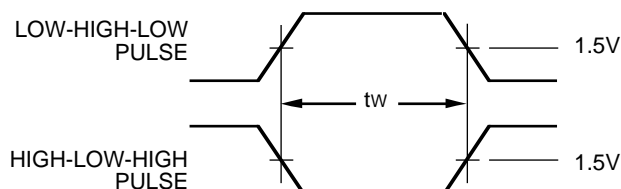

2611 drw 06

PROPAGATION DELAY

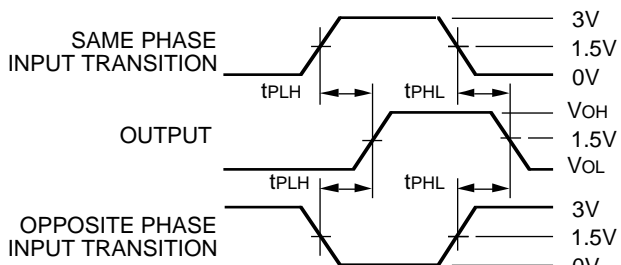

2611 drw 07

ENABLE AND DISABLE TIMES

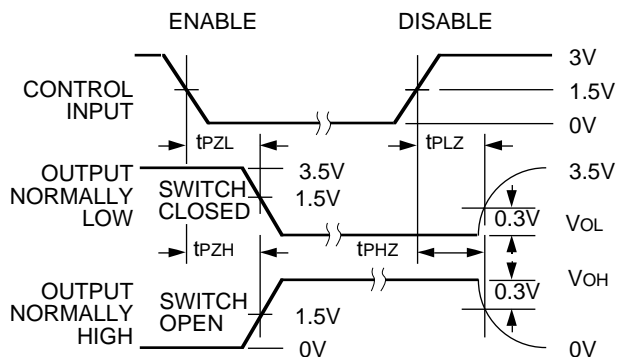

2611 drw 08

NOTES:

- Diagram shown for input Control Enable-LOW and input Control Disable-HIGH
- Pulse Generator for All Pulses: Rate \leq 1.0MHz; $t_f \leq$ 2.5ns; $t_r \leq$ 2.5ns

ORDERING INFORMATION

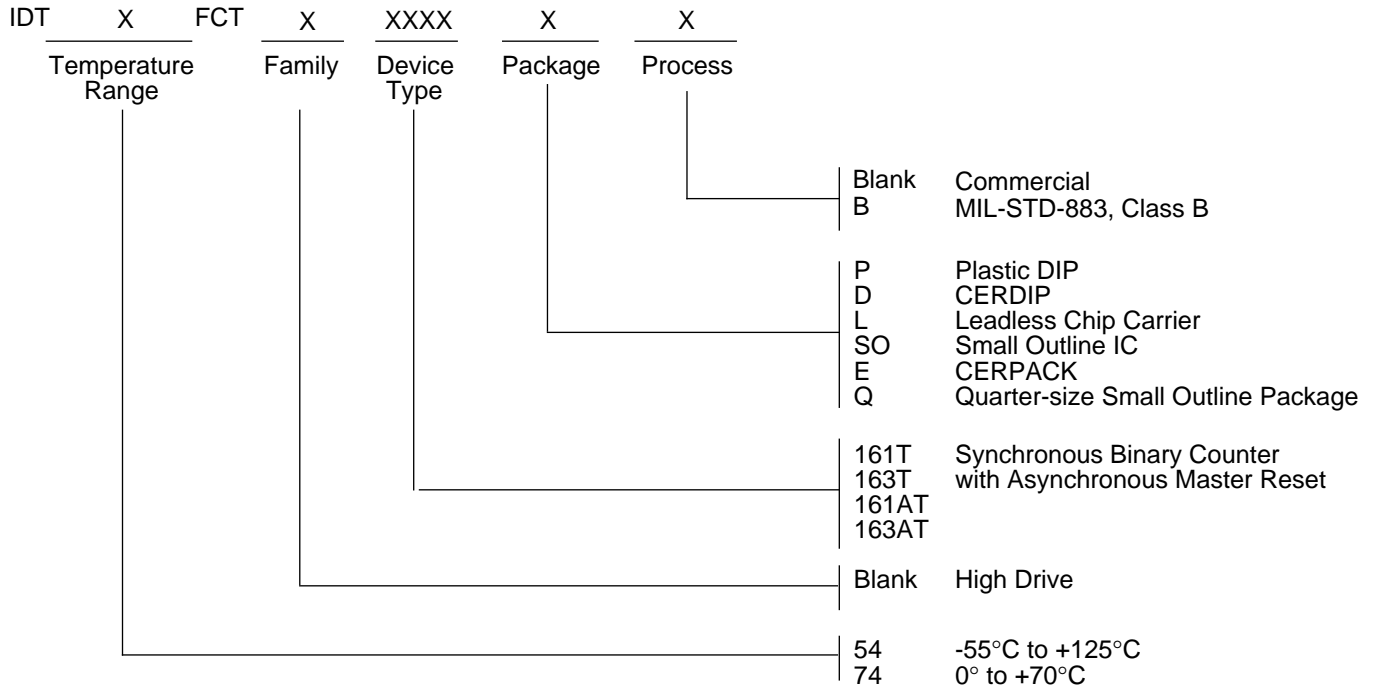

2611 drw 09

This datasheet has been downloaded from:

www.DatasheetCatalog.com

Datasheets for electronic components.



LittleDiode supplies new, hard to find or obsolete electronic components and semiconductors all over the world.

With over two million different components listed you are sure to find the part you need.

Feel free to visit us today at our online store:

LittleDiode.com

Looking forward to providing you with the best possible service.