

DATA SHEET

For a complete data sheet, please also download:

- The IC04 LOCMOS HE4000B Logic Family Specifications HEF, HEC
- The IC04 LOCMOS HE4000B Logic Package Outlines/Information HEF, HEC

HEF4526B

MSI

Programmable 4-bit binary down counter

Product specification
File under Integrated Circuits, IC04

January 1995

Programmable 4-bit binary down counter

HEF4526B
MSI

DESCRIPTION

The HEF4526B is a synchronous programmable 4-bit binary down counter with an active HIGH and an active LOW clock input (CP_0 , \overline{CP}_1), an asynchronous parallel load input (PL), four parallel inputs (P_0 to P_3), a cascade feedback input (CF), four buffered parallel outputs (O_0 to O_3), a terminal count output (TC) and an overriding asynchronous master reset input (MR).

This device is a programmable, cascadable down counter with a decoded TC output for divide-by-n applications. In single stage applications the TC output is connected to PL. CF allows cascade divide-by-n operation with no additional gates required.

Information on P_0 to P_3 is loaded into the counter while PL is HIGH, independent of all other input conditions except MR, which must be LOW. When PL and \overline{CP}_1 are LOW, the counter advances on a LOW to HIGH transition of CP_0 . When PL is LOW and CP_0 is HIGH, the counter advances on a HIGH to LOW transition of \overline{CP}_1 . TC is HIGH when the counter is in the zero state ($O_0 = O_1 = O_2 = O_3 = \text{LOW}$) and CF is HIGH and PL is LOW. A HIGH on MR resets the counter (O_0 to $O_3 = \text{LOW}$) independent of other input conditions.

Schmitt-trigger action in the clock input makes the circuit highly tolerant to slower clock rise and fall times.

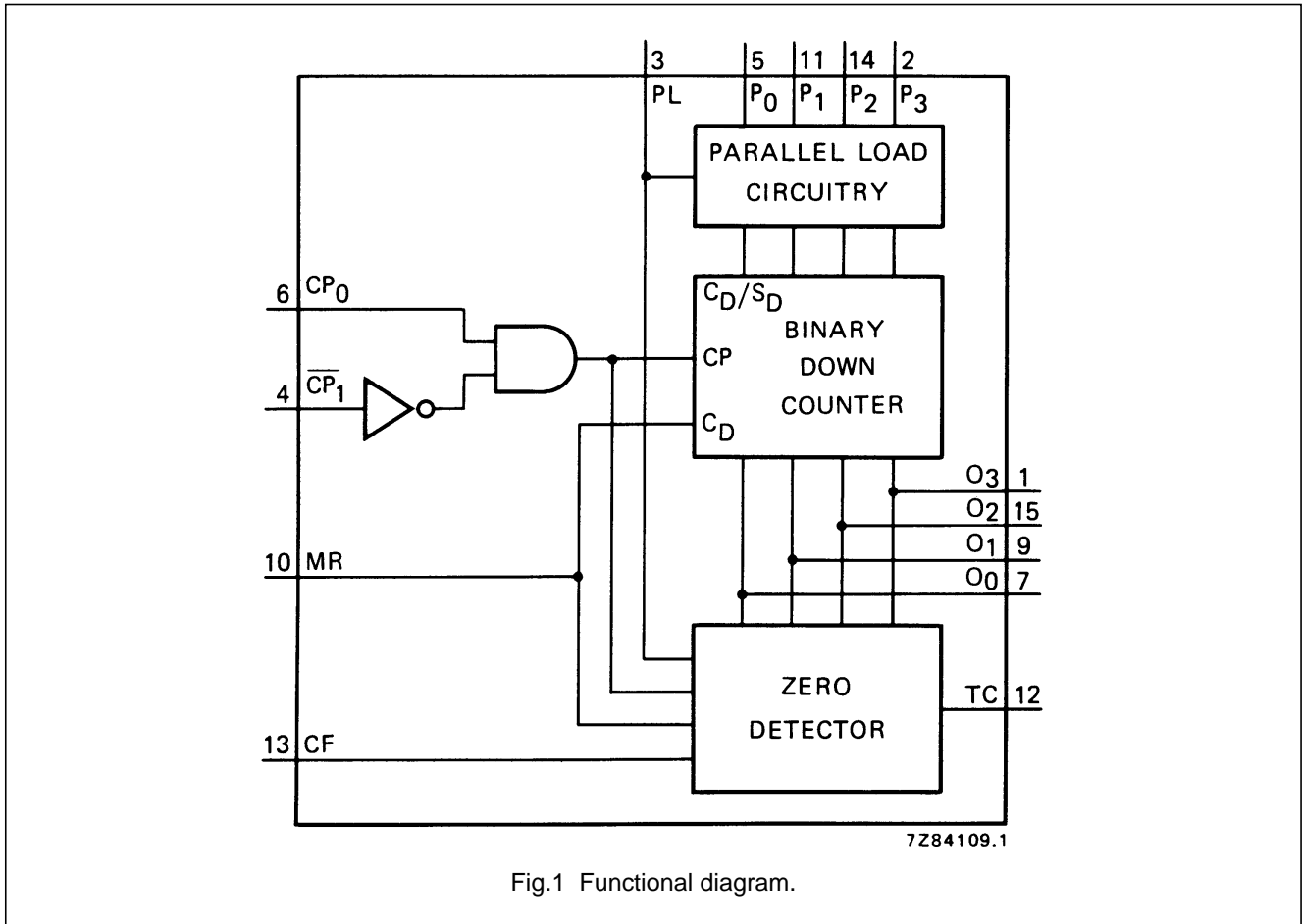

Fig.1 Functional diagram.

FAMILY DATA, I_{DD} LIMITS category MSI

See Family Specifications

Programmable 4-bit binary down counter

HEF4526B
MSI

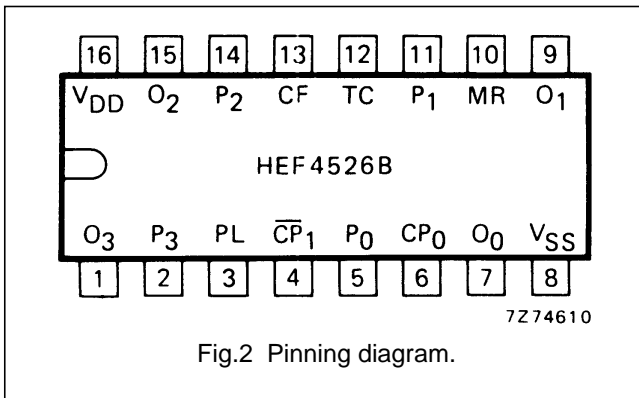

HEF4526BP(N): 16-lead DIL; plastic (SOT38-1)
 HEF4526BD(F): 16-lead DIL; ceramic (cerdip) (SOT74)
 HEF4526BT(D): 16-lead SO; plastic (SOT109-1)
 (): Package Designator North America

PINNING

- PL parallel load input
- P₀ to P₃ parallel inputs
- CF cascade feedback input
- CP₀ clock input (LOW to HIGH, triggered)
- \overline{CP}_1 clock input (HIGH to LOW, triggered)
- MR asynchronous master reset input
- TC terminal count output
- O₀ to O₃ buffered parallel outputs

COUNTING MODE

CF = HIGH; PL = LOW; MR = LOW

COUNT	OUTPUTS			
	O ₃	O ₂	O ₁	O ₀
15	H	H	H	H
14	H	H	H	L
13	H	H	L	H
12	H	H	L	L
11	H	L	H	H
10	H	L	H	L
9	H	L	L	H
8	H	L	L	L
7	L	H	H	H
6	L	H	H	L
5	L	H	L	H
4	L	H	L	L
3	L	L	H	H
2	L	L	H	L
1	L	L	L	H
0	L	L	L	L

FUNCTION TABLE

MR	PL	CP ₀	\overline{CP}_1	MODE
H	X	X	X	reset (asynchronous)
L	H	X	X	preset (asynchronous)
L	L	↗	H	no change
L	L	L	↘	no change
L	L	↘	X	no change
L	L	X	↗	no change
L	L	↗	L	counter advances
L	L	H	↘	counter advances

Notes

1. H = HIGH state (the more positive voltage)
 L = LOW state (the less positive voltage)
 X = state is immaterial
 ↗ = positive-going transition
 ↘ = negative-going transition

Programmable 4-bit binary down counter

HEF4526B
MSI

SINGLE STAGE OPERATION

Divide-by-n; MR = LOW; CF = HIGH; \overline{CP}_1 = LOW

PL	P ₃	P ₂	P ₁	P ₀	DIVIDE BY	TC OUTPUT PULSE WIDTH
L	X	X	X	X	16	one clock period
TC	H	H	H	H	15	clock pulse HIGH
TC	H	H	H	L	14	
TC	H	H	L	H	13	
TC	H	H	L	L	12	
TC	H	L	H	H	11	
TC	H	L	H	L	10	
TC	H	L	L	H	9	
TC	H	L	L	L	8	
TC	L	H	H	H	7	
TC	L	H	H	L	6	
TC	L	H	L	H	5	
TC	L	H	L	L	4	
TC	L	L	H	H	3	
TC	L	L	H	L	2	
TC	L	L	L	H	1	
TC	L	L	L	L	no operation	

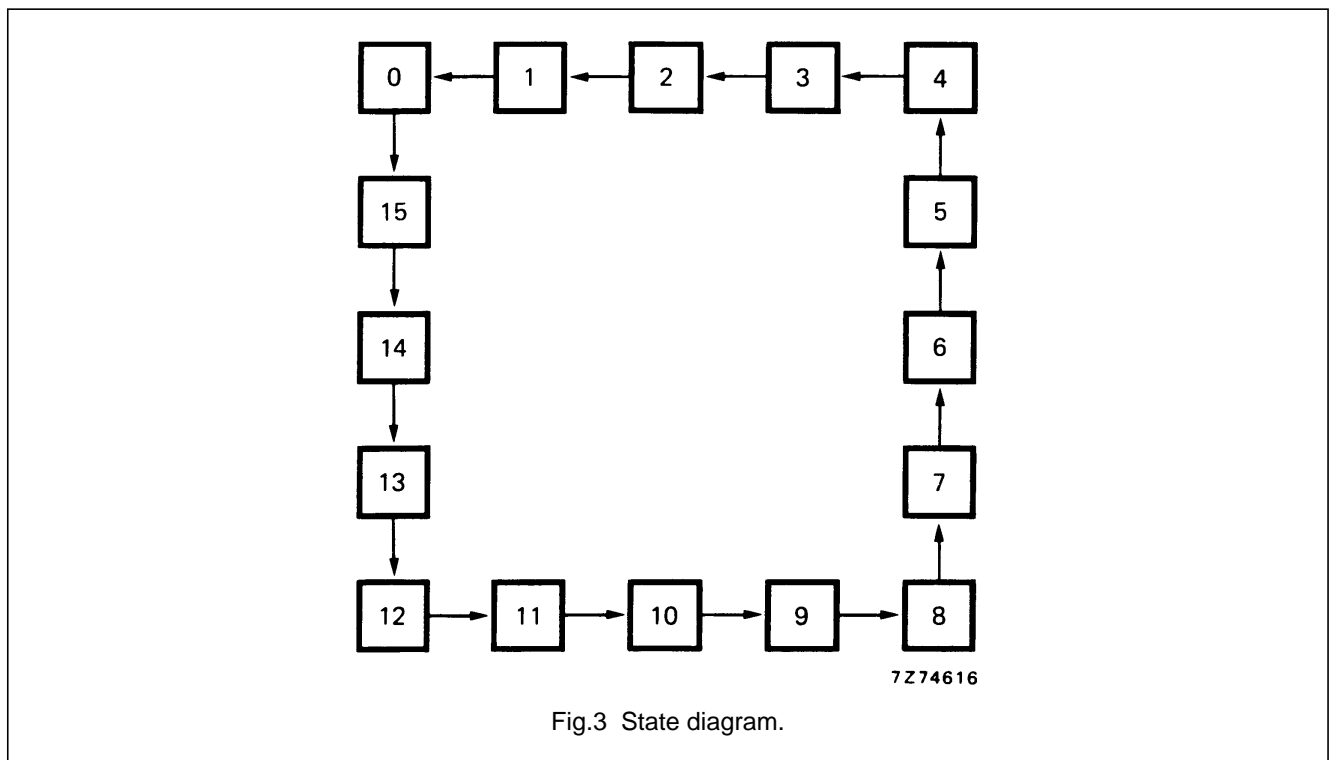

Programmable 4-bit binary down counter

HEF4526B
MSI

AC CHARACTERISTICS

 $V_{SS} = 0\text{ V}$; $T_{amb} = 25\text{ }^{\circ}\text{C}$; input transition times $\leq 20\text{ ns}$

	V_{DD} V	TYPICAL FORMULA FOR P (μW)	
Dynamic power dissipation per package (P)	5	$1000 f_i + \sum (f_o C_L) \times V_{DD}^2$	where f_i = input freq. (MHz) f_o = output freq. (MHz) C_L = load capacitance (pF) $\sum (f_o C_L)$ = sum of outputs V_{DD} = supply voltage (V)
	10	$4000 f_i + \sum (f_o C_L) \times V_{DD}^2$	
	15	$10\,000 f_i + \sum (f_o C_L) \times V_{DD}^2$	

AC CHARACTERISTICS

 $V_{SS} = 0\text{ V}$; $T_{amb} = 25\text{ }^{\circ}\text{C}$; $C_L = 50\text{ pF}$; input transition times $\leq 20\text{ ns}$

	V_{DD} V	SYMBOL	MIN.	TYP.	MAX.	TYPICAL EXTRAPOLATION FORMULA		
Propagation delays $CP_0, \overline{CP}_1 \rightarrow O_n$ HIGH to LOW	5	t_{PHL}		150	300	ns	$123\text{ ns} + (0,55\text{ ns/pF}) C_L$	
	10			65	130	ns	$54\text{ ns} + (0,23\text{ ns/pF}) C_L$	
	15			50	100	ns	$42\text{ ns} + (0,16\text{ ns/pF}) C_L$	
	LOW to HIGH	5	t_{PLH}		150	300	ns	$123\text{ ns} + (0,55\text{ ns/pF}) C_L$
		10			65	130	ns	$54\text{ ns} + (0,23\text{ ns/pF}) C_L$
		15			50	100	ns	$42\text{ ns} + (0,16\text{ ns/pF}) C_L$
$CP_0, \overline{CP}_1 \rightarrow TC$ HIGH to LOW	5	t_{PHL}		210	420	ns	$183\text{ ns} + (0,55\text{ ns/pF}) C_L$	
	10			90	180	ns	$79\text{ ns} + (0,23\text{ ns/pF}) C_L$	
	15			70	140	ns	$62\text{ ns} + (0,16\text{ ns/pF}) C_L$	
	LOW to HIGH	5	t_{PLH}		210	420	ns	$183\text{ ns} + (0,55\text{ ns/pF}) C_L$
		10			90	180	ns	$79\text{ ns} + (0,23\text{ ns/pF}) C_L$
		15			70	140	ns	$62\text{ ns} + (0,16\text{ ns/pF}) C_L$
PL $\rightarrow O_n$ HIGH to LOW	5	t_{PHL}		200	400	ns	$173\text{ ns} + (0,55\text{ ns/pF}) C_L$	
	10			80	160	ns	$69\text{ ns} + (0,23\text{ ns/pF}) C_L$	
	15			60	120	ns	$52\text{ ns} + (0,16\text{ ns/pF}) C_L$	
	LOW to HIGH	5	t_{PLH}		180	360	ns	$153\text{ ns} + (0,55\text{ ns/pF}) C_L$
		10			70	140	ns	$59\text{ ns} + (0,23\text{ ns/pF}) C_L$
		15			50	100	ns	$42\text{ ns} + (0,16\text{ ns/pF}) C_L$
MR $\rightarrow O_n$ HIGH to LOW	5	t_{PHL}		140	280	ns	$113\text{ ns} + (0,55\text{ ns/pF}) C_L$	
	10			55	110	ns	$44\text{ ns} + (0,23\text{ ns/pF}) C_L$	
	15			40	80	ns	$32\text{ ns} + (0,16\text{ ns/pF}) C_L$	
	Output transition times HIGH to LOW	5	t_{THL}		60	120	ns	$10\text{ ns} + (1,0\text{ ns/pF}) C_L$
		10			30	60	ns	$9\text{ ns} + (0,42\text{ ns/pF}) C_L$
		15			20	40	ns	$6\text{ ns} + (0,28\text{ ns/pF}) C_L$
LOW to HIGH	5	t_{TLH}		60	120	ns	$10\text{ ns} + (1,0\text{ ns/pF}) C_L$	
	10			30	60	ns	$9\text{ ns} + (0,42\text{ ns/pF}) C_L$	
	15			20	40	ns	$6\text{ ns} + (0,28\text{ ns/pF}) C_L$	

Programmable 4-bit binary down counter

HEF4526B
MSI**AC CHARACTERISTICS** $V_{SS} = 0\text{ V}$; $T_{amb} = 25\text{ }^{\circ}\text{C}$; $C_L = 50\text{ pF}$; input transition times $\leq 20\text{ ns}$

	V_{DD} V	SYMBOL	MIN.	TYP.	MAX.	
Minimum clock pulse width CP_0 LOW	5	t_{WCPL}	80	40	ns	see also waveforms Figs 5 and 6
	10		40	20	ns	
	15		30	15	ns	
Minimum clock pulse width \overline{CP}_1 HIGH	5	t_{WCPH}	80	40	ns	
	10		40	20	ns	
	15		30	15	ns	
Minimum PL pulse width; HIGH	5	t_{WPLH}	100	50	ns	
	10		40	20	ns	
	15		32	16	ns	
Minimum MR pulse width; HIGH	5	t_{WMRH}	130	65	ns	
	10		50	25	ns	
	15		40	20	ns	
Hold time $P_n \rightarrow PL$	5	t_{hold}	30	5	ns	
	10		20	5	ns	
	15		15	5	ns	
Set-up time $P_n \rightarrow PL$	5	t_{su}	30	0	ns	
	10		20	0	ns	
	15		15	0	ns	
Maximum clock pulse frequency PL = LOW	5	f_{max}	6	12	MHz	see note 1
	10		12	25	MHz	
	15		16	32	MHz	

Note

1. In the divide-by-n mode (PL connected to TC), one has to observe the maximum HIGH to LOW propagation delay for CP to TC, before applying the next clock pulse.

Programmable 4-bit binary down counter

HEF4526B
MSI

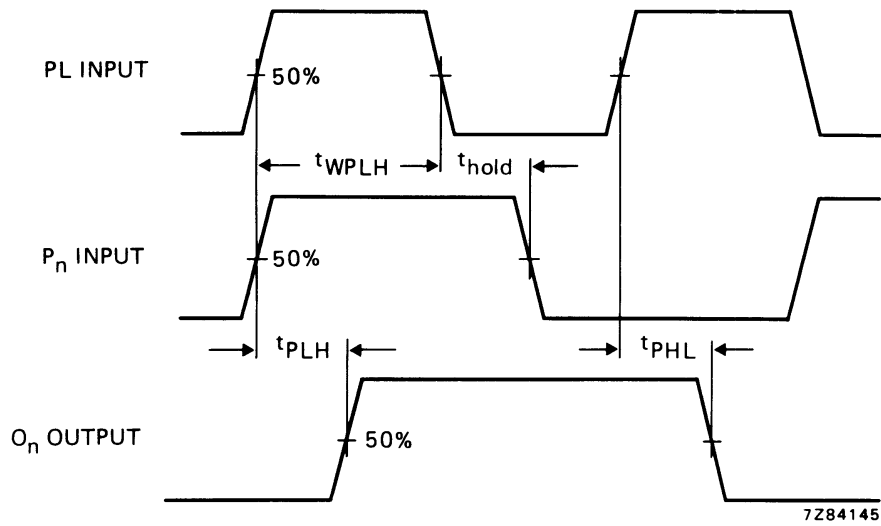

Fig.5 Waveforms showing minimum PL pulse width, propagation delays for PL, P_n to O_n and hold time for PL to P_n.

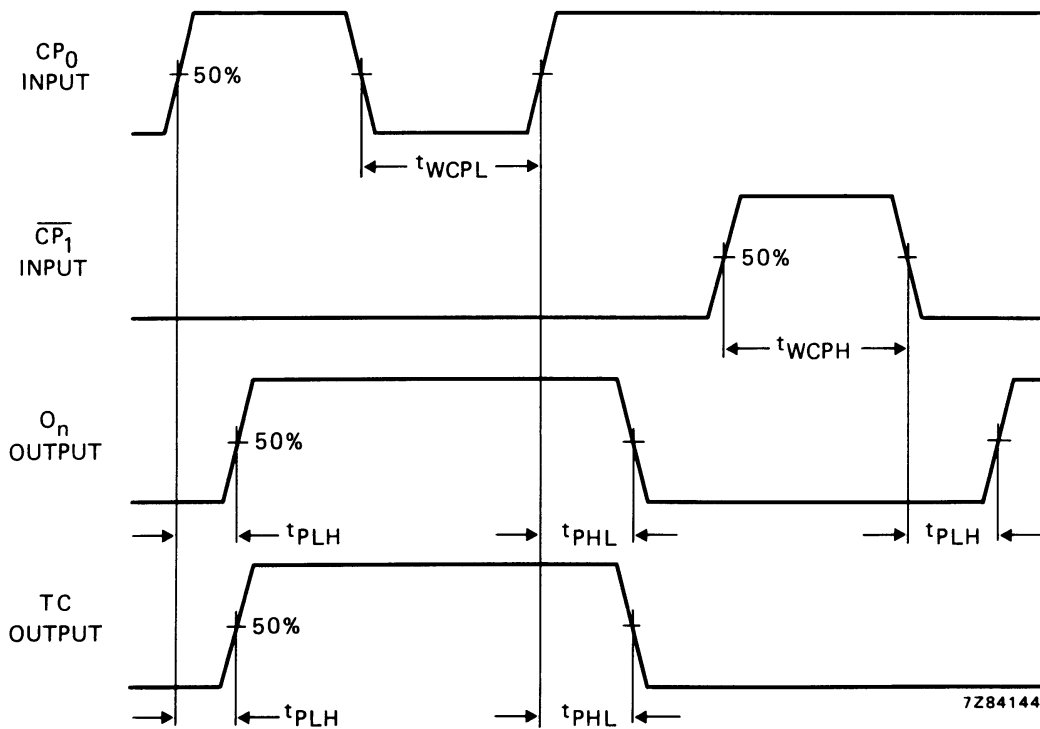

Fig.6 Waveforms showing minimum CP₀ and CP₁ pulse widths, propagation delays for CP₀, CP₁ to O_n and TC.

Programmable 4-bit binary down counter

HEF4526B
MSI

APPLICATION INFORMATION

Some examples of applications for the HEF4526B are:

- Divide-by-n counter
- Programmable frequency divider

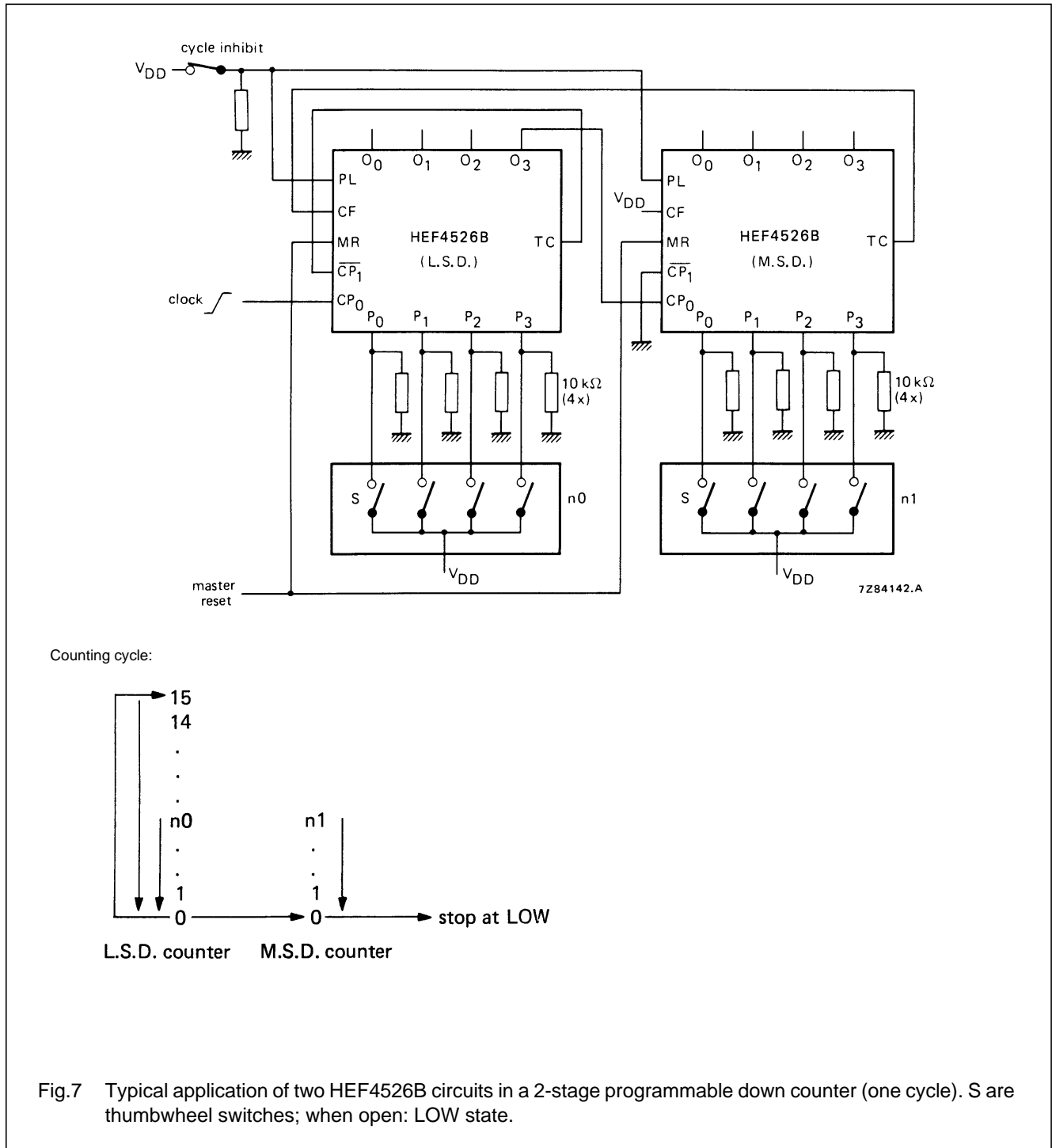
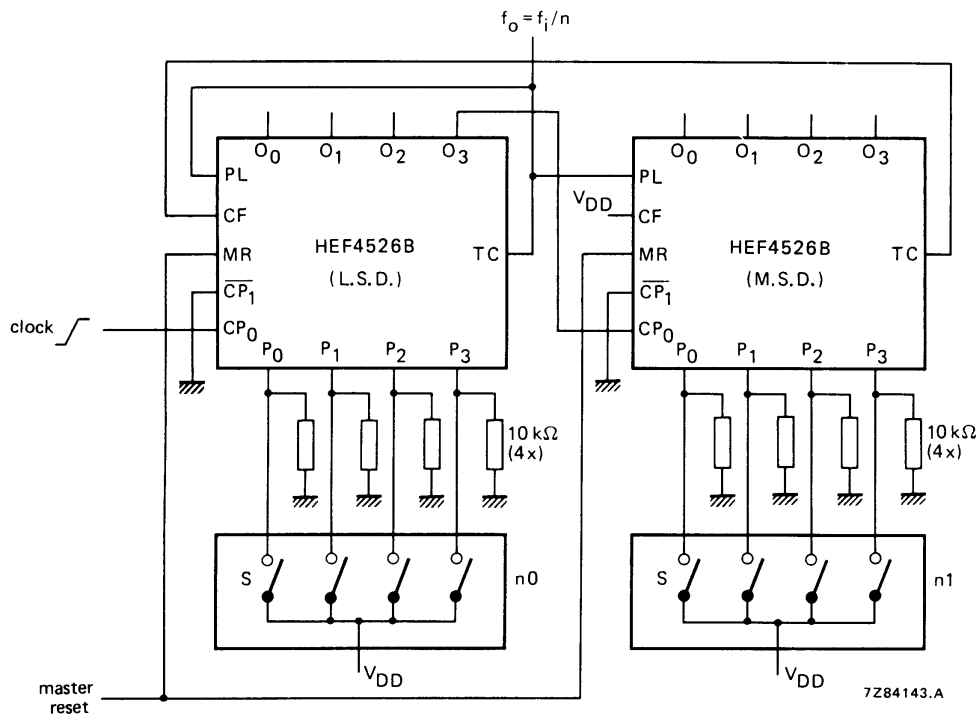

Fig.7 Typical application of two HEF4526B circuits in a 2-stage programmable down counter (one cycle). S are thumbwheel switches; when open: LOW state.

Programmable 4-bit binary down counter

HEF4526B
MSI



Counting cycle:

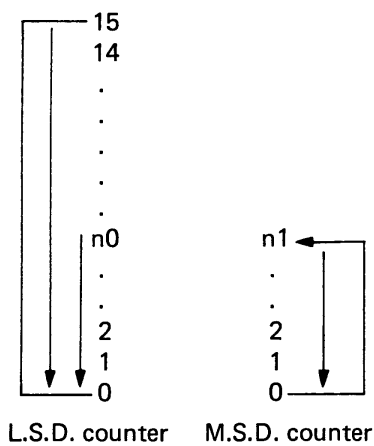

Fig.8 Typical application of two HEF4526B circuits in a 2-stage programmable frequency divider. S are thumbwheel switches; when open: LOW state.



LittleDiode supplies new, hard to find or obsolete electronic components and semiconductors all over the world.

With over two million different components listed you are sure to find the part you need.

Feel free to visit us today at our online store:

LittleDiode.com

Looking forward to providing you with the best possible service.