

HA17301P

Quad Operational Amplifier

HITACHI

Description

The HA17301P is an internal-compensation quad operational amplifier that operates on a single-voltage power supply. Typical applications for the HA17301P include waveform generators, voltage regulators, logic circuits, and voltage-controlled oscillators.

Features

- Wide operating temperature range
- Single-voltage power supply operation
- Internal phase compensation
- Low input bias current

Pin Arrangement

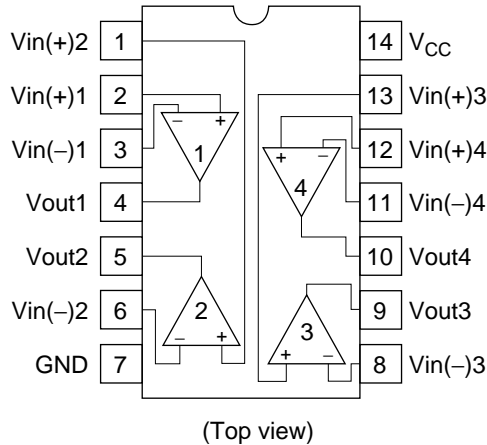

Circuit Structure (1/4)

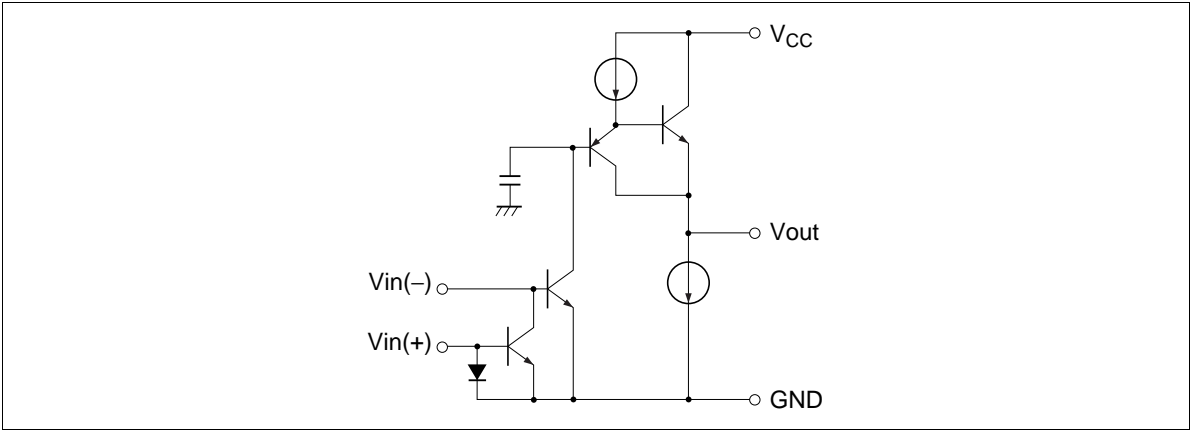

Absolute Maximum Ratings ($T_a = 25^\circ\text{C}$)

Item	Symbol	Ratings	Unit
Power-supply voltage	V_{CC}	28	V
Noninverting input current	I_r	5	mA
Sink current	I_o sink	50	mA
Source current	I_o source	50	mA
Allowable power dissipation*	P_T	625	mW
Operating temperature	T_{opr}	-20 to +75	$^\circ\text{C}$
Storage temperature	T_{stg}	-55 to +125	$^\circ\text{C}$

Note: This is the allowable value up to $T_a = 50^\circ\text{C}$ for the HA17301P. Derate by 8.3 mW/ $^\circ\text{C}$ above that temperature.

Electrical Characteristics ($V_{CC} = +15\text{ V}$, $R_L = 5.0\text{ k}\Omega$, $T_a = 25^\circ\text{C}$)

Item	Symbol	Min	Typ	Max	Unit	Test Conditions
Voltage gain	A_{VD}	1,000	1,400	—	V/V	
Supply current	I_{CO}	—	7.7	10	mA	Non inverting input open
	I_{CG}	—	8.3	14	mA	Non inverting input grounded
Input bias current	I_{IB}	—	80	300	nA	$R_L = \infty$
Current mirror gain	A_I	0.80	0.94	1.16	A/A	$I_r = 200\ \mu\text{A}$
Output source current	I_o source	3	13	—	mA	$V_{OH} = 0.4\text{ V}$
		—	10	—	mA	$V_{OH} = 9.0\text{ V}$
Output sink current	I_o sink	0.5	0.75	—	mA	$V_{OL} = 0.4\text{ V}$
Output voltage	V_{OH}	13.5	13.9	—	V	
	$V_{OL(inv)}$	—	0.04	0.1	V	Inverting input driven
	$V_{OL(non)}$	—	0.55	—	V	Non inverting input driven
Input resistance	R_{in}	0.1	1.0	—	$\text{M}\Omega$	Inverting input only
Slew rate	SR	—	0.2	—	V/ μs	$C_L = 100\text{ pF}$, $R_L = 5.0\text{ k}\Omega$
Bandwidth	BW	—	2.6	—	MHz	$A_{VD} = 1$
Phase margin	ϕ_m	—	87	—	deg	
Power-supply rejection ratio	PSRR	—	63	—	dB	$f = 100\text{ Hz}$
Channel separation	CS	—	63	—	dB	$f = 1.0\text{ kHz}$

HA17301P Application Examples

The HA17301P is a quad operational amplifier, and consists of four operational amplifier circuits and one bias current circuit. The HA17301P features a wide operating temperature range, single-voltage power supply operation, internal phase compensation, a wide zero-cross bandwidth, a low input bias current, and a high open-loop gain. Thus the HA17301P can be used in a wide range of applications. This section describes several applications using the HA17301P.

HA17301 Circuit Operation

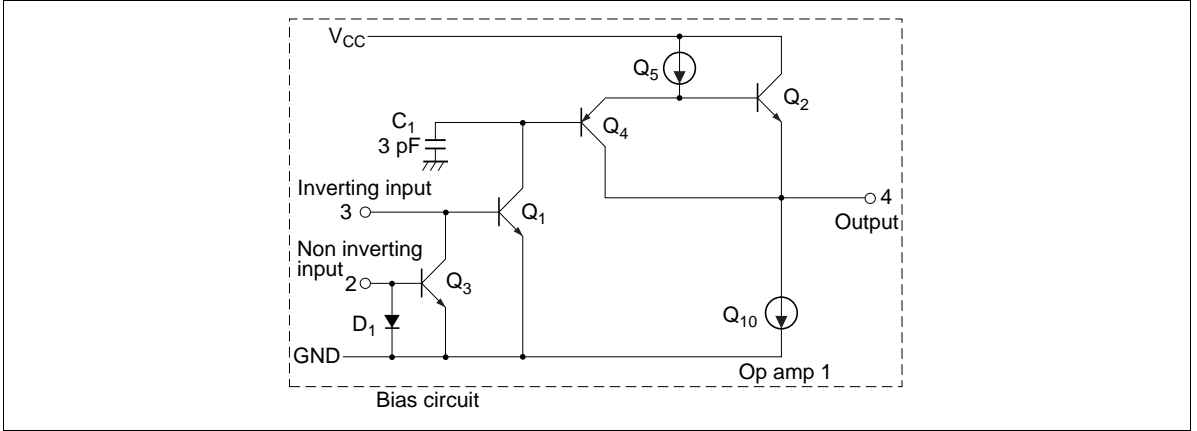

Figure 1 HA17301 Internal Equivalent Circuit

Figure 1 shows the internal equivalent circuit for the HA17301P bias circuit and one operational amplifier circuit (Op amp 1).

Op amp 1 is basically an emitter ground type operational amplifier in which the input transistor Q_1 , the buffer transistor Q_4 , the current source transistor Q_5 , the output emitter-follower transistor Q_2 , and the current source transistor Q_{10} form an inverting amplifier. The voltage gain of this circuit is all given by the transistor Q_1 , and the adoption of the current-supply load Q_3 allows this circuit to provide a large open-loop gain even at low power-supply voltages. Next, the emitter-follower transistor Q_2 lowers the output impedance of this circuit. The use of the power-supply transistor Q_{10} as the load for Q_2 gives this circuit an extremely large dynamic range, and essentially an amplitude from ground to $(V_{CC} - 1)$ can be acquired. Also, the buffer transistor Q_4 is used to reduce the input current without increasing the DC input voltage level. Since the capacitor C_1 is used to preserve stability when this inverting amplifier is used as a closed circuit, no external compensation is required.

Now consider the non inverting circuit. Assuming that the current amplification ratio provided by Q_3 is adequately large for the current flowing into the non inverting input, then all that current will flow through diode D_1 and the voltage drop induced in the diode D_1 by this input current will be applied to the Q_3 base-emitter junction. Therefore, if D_1 and Q_3 are matched, a current equal to the input current will flow in the Q_3 emitter. Assuming that the current amplification ratio provided by Q_3 is adequately large, a current equal to the input current will flow in the Q_3 collector. This is called a “current mirror”, and when an external feedback resistor is used, a current equal to the non inverting input current will flow in this resistor and thus determine the output voltage.

Inverting Amplifier

There are three bias techniques for biasing the inverting amplifier, the single power supply bias technique, the NV_{BE} bias technique, and the load voltage bias technique.

1. Single Power Supply Bias Technique

Figure 2 shows a common AC amplifier that is biased by the same power supply as the supply that operates the amplifier.

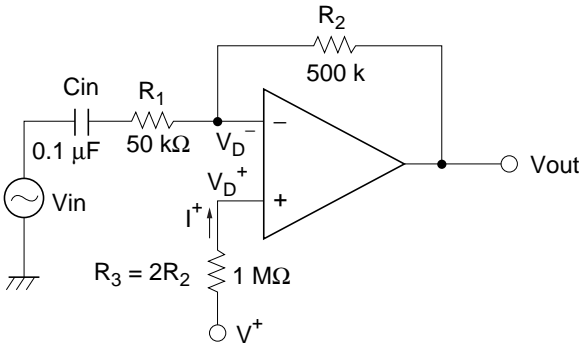

Figure 2 Single Power Supply Bias Technique

$$\frac{V_{out}}{V_{in}} = -\frac{R_2}{R_1} \quad (1)$$

2. NV_{BE} Bias Technique

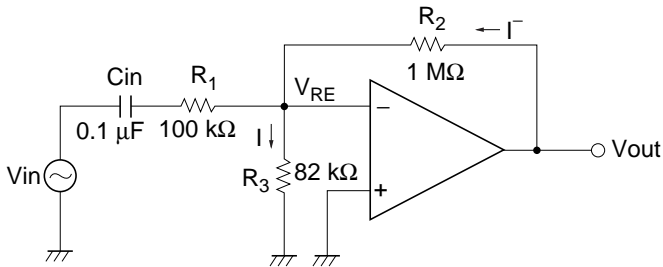

Figure 3 NV_{BE} Bias Technique

This is the most useful application of an inverting AC amplifier. In this circuit, the input bias voltage V_{BE} for the inverting input is determined by the current that flows to ground through the resistor R_3 .

$$\frac{V_{out}}{V_{in}} = -\frac{R_2}{R_1} \quad (2)$$

Triangular Wave oscillator

Triangular waveforms are usually acquired by integrating an alternating positive and negative DC voltage. Figure 4 shows the relation between the input and output in this circuit.

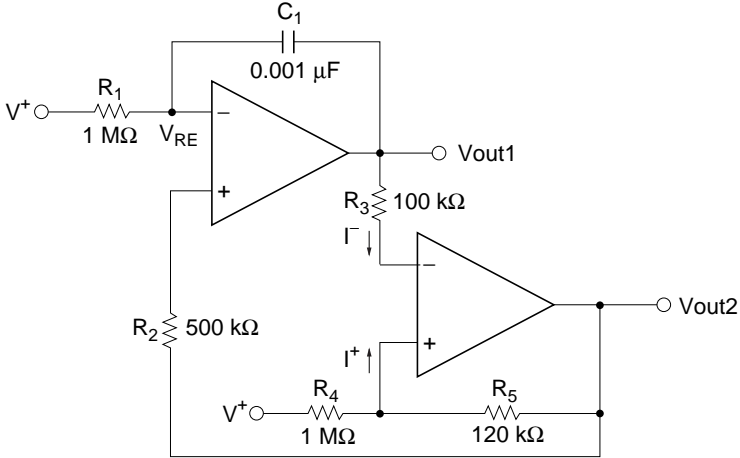

Figure 4 Triangular Wave Oscillator

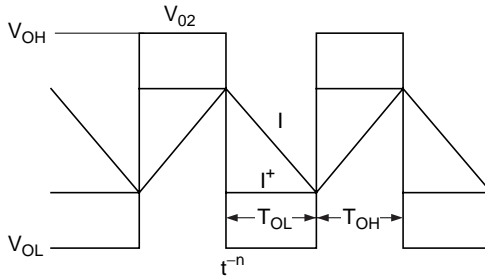

Figure 5 Triangular Wave Generator Operation

$$T_{OL} = \frac{C_1 R_1 R_3 V_{OH}}{R_5 (V^+ - V_{BE})} \quad (3)$$

$$T_{OH} = \frac{C_1 R_3 V^+}{R_5 \left(\frac{V_{OH}}{R_2} - \frac{V^+ - V_{BE}}{R_1} \right)} \quad (4)$$

Here, if $R_1 = 2 \cdot R_2$, $V_{OH} = V^+$, and $V^+ > V_{BE}$, then:

$$T_{OH} + T_{OL} = \frac{2C_1 R_1 R_3}{R_5} \quad (5)$$

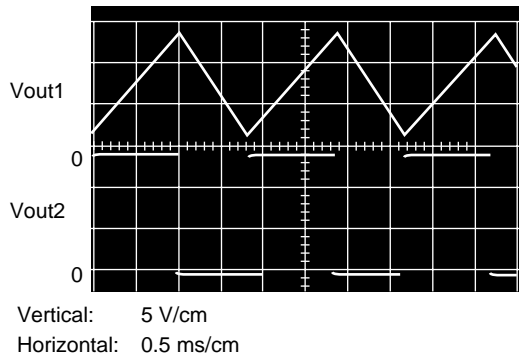

Figure 6 Triangular Wave Generator Operating Waveform

Table 1

Test Item		Tested Value	Calculated Value	Unit	Test Condition
Triangular wave generator	T_{OH}	1.06	0.83	ms	$V_{CC} = 15\text{ V}$, $V^+ = 15\text{ V}$, $C_1 = 0.001\text{ }\mu\text{F}$,
	T_{OL}	0.82	0.83	ms	$R_1 = 1\text{ M}\Omega$, $R_2 = 500\text{ k}\Omega$, $R_3 = 100\text{ k}\Omega$,
	V_{OH}	13.5	14	V	$R_4 = 1\text{ M}\Omega$, $R_5 = 120\text{ k}\Omega$
	V_{OL}	1.5	1.5	V	Figure 4

Comparators

This section describes three comparator circuits implemented using the HA17301P, a positive input voltage comparator, a negative input voltage comparator, and a power voltage comparator.

1. Positive Input Voltage Comparator

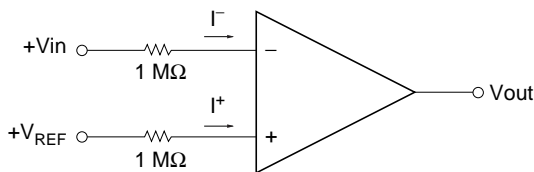

Figure 7 Positive Input Voltage Comparator

V_{out} in the circuit shown in figure 7 will be V_{OH} when $I^- < I^+$ and V_{OL} when $I^- > I^+$. To assure that this circuit operates correctly, the reference voltage must be greater than V_{BE} .

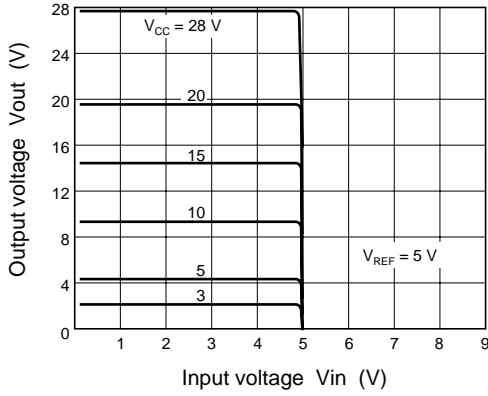

Figure 8 Positive Input Voltage Comparator Operating Characteristics (1)

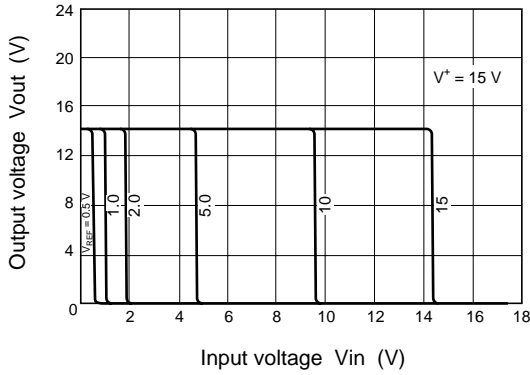

Figure 9 Positive Input Voltage Comparator Operating Characteristics (2)

2. Negative Input Voltage Comparator

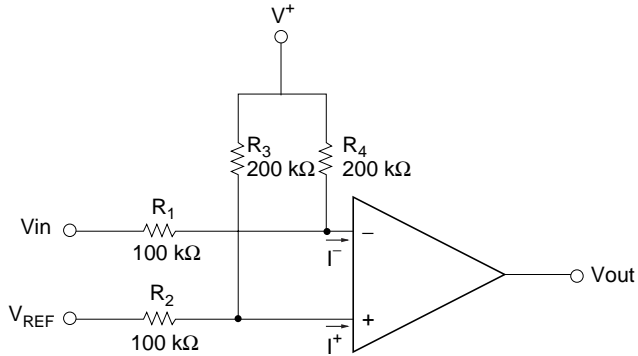

Figure 10 Negative Input Voltage Comparator

$$V_{IN} > R_1 \left\{ V_{BE} \left(\frac{1}{R_1} + \frac{1}{R_4} \right) - \frac{V^+}{R_4} \right\} \quad (6)$$

If resistor R_4 is chosen so that formula 6 holds, and

$$V_{REF} > R_2 \left\{ V_{BE} \left(\frac{1}{R_2} + \frac{1}{R_3} \right) - \frac{V^+}{R_3} \right\} \quad (7)$$

if resistor R_4 is chosen so that formula 7 holds, then even if V_{IN} and V_{REF} are negative, V_{out} will be V_{OH} when $\Gamma < \Gamma^+$ and V_{OL} when $\Gamma > \Gamma^+$, as was the case for the positive input voltage comparator.

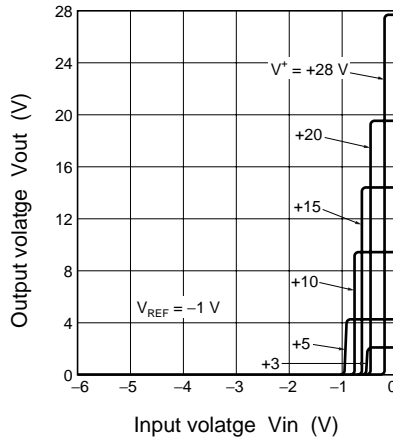

Figure 11 Negative Input Voltage Comparator Operating Characteristics (1)

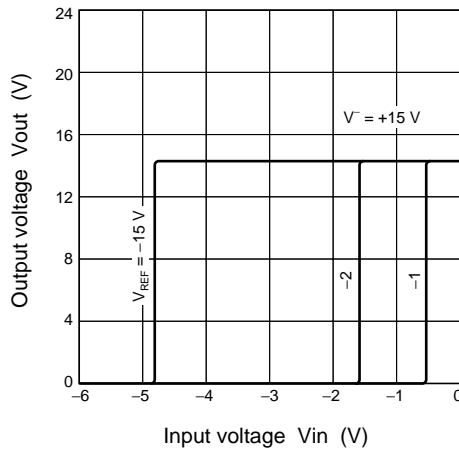

Figure 12 Negative Input Voltage Comparator Operating Characteristics (2)

3. Power Comparator

As shown in figure 13, adding an external transistor allows the circuit to drive loads that require a larger current than the output current that the HA17301P can supply.

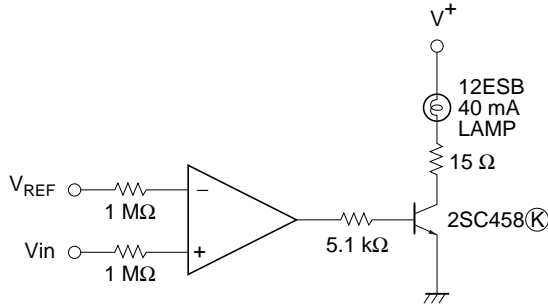

Figure 13 Power Comparator

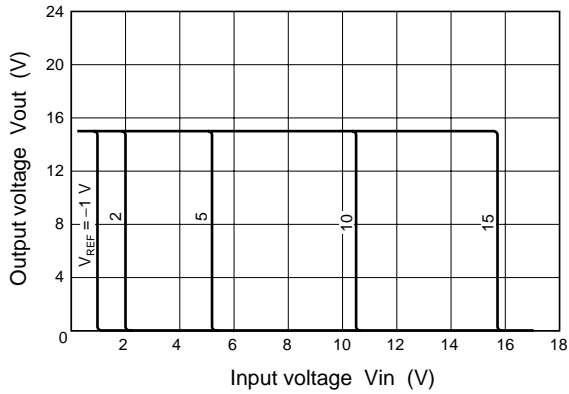
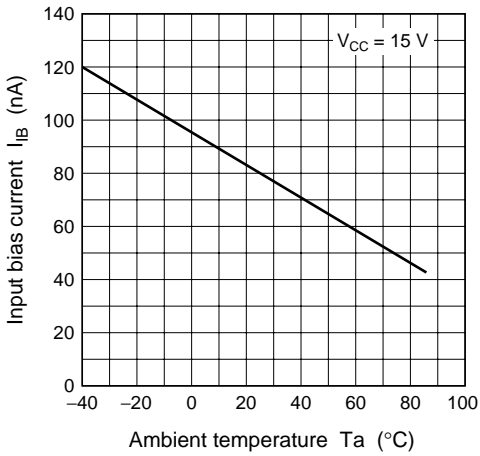

Figure 14 Power Comparator Operating Characteristics

Characteristic Curves

Input Bias Current vs. Ambient Temperature



Supply current vs. Power-Supply Voltage (1)

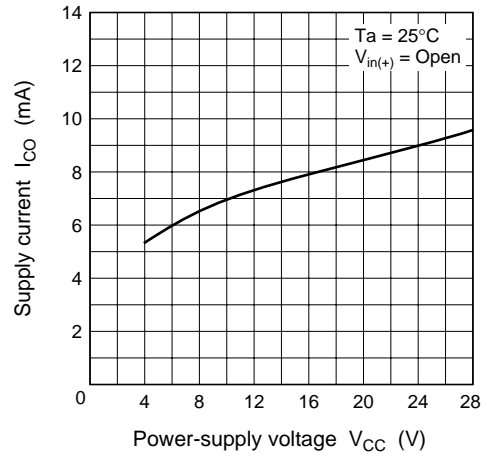

Supply current vs. Power-Supply Voltage (2)

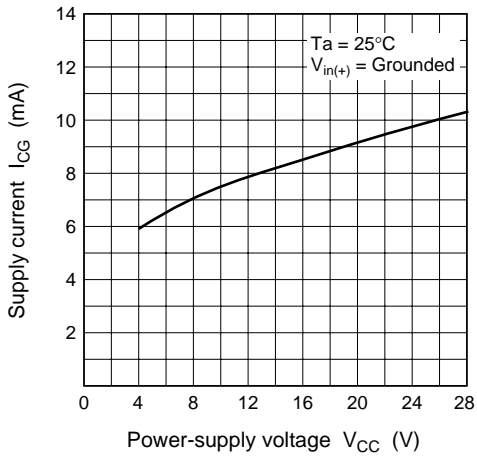

Current Mirror Gain vs. Ambient Temperature

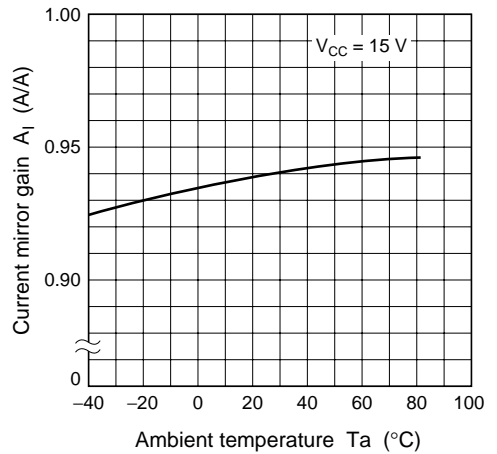

Output Source Current vs. Power-Supply Voltage

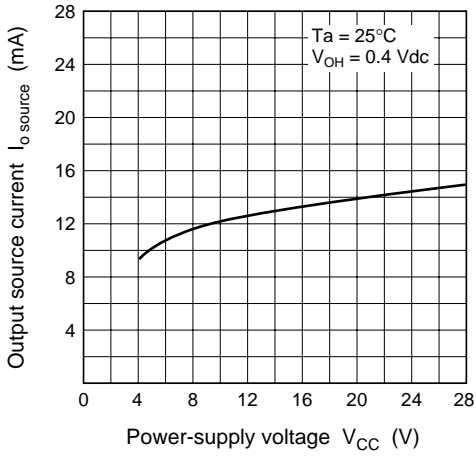

Output Sink Current vs. Power-Supply Voltage

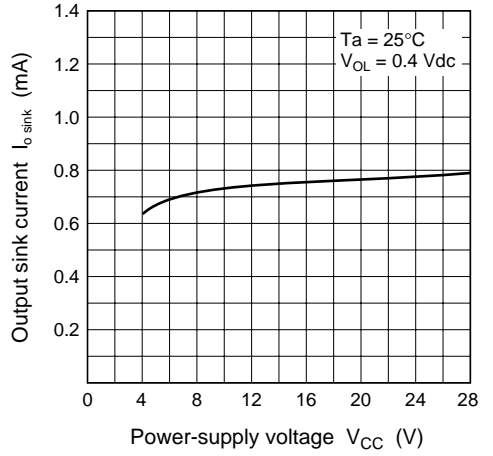

Voltage Gain vs. Frequency

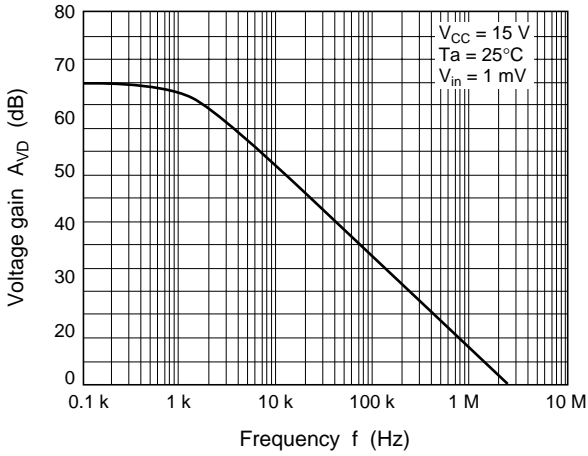

Voltage Gain vs. Ambient Temperature

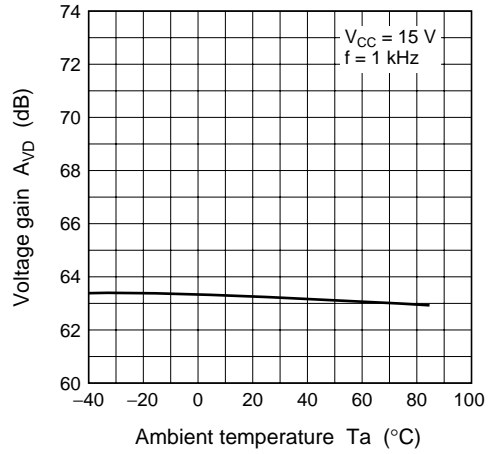

Package Dimensions

Unit: mm

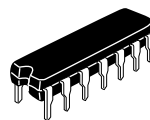
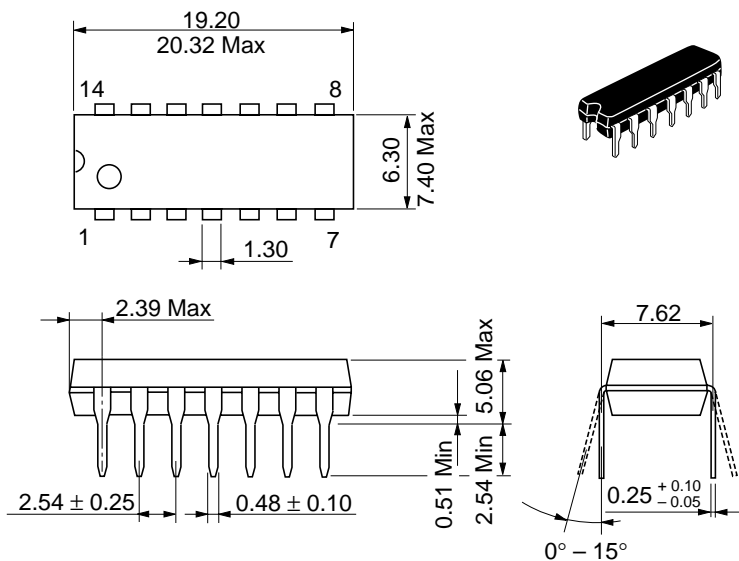

Hitachi Code	DP-14
JEDEC	Conforms
EIAJ	Conforms
Mass (reference value)	0.97 g

Cautions

1. Hitachi neither warrants nor grants licenses of any rights of Hitachi's or any third party's patent, copyright, trademark, or other intellectual property rights for information contained in this document. Hitachi bears no responsibility for problems that may arise with third party's rights, including intellectual property rights, in connection with use of the information contained in this document.
2. Products and product specifications may be subject to change without notice. Confirm that you have received the latest product standards or specifications before final design, purchase or use.
3. Hitachi makes every attempt to ensure that its products are of high quality and reliability. However, contact Hitachi's sales office before using the product in an application that demands especially high quality and reliability or where its failure or malfunction may directly threaten human life or cause risk of bodily injury, such as aerospace, aeronautics, nuclear power, combustion control, transportation, traffic, safety equipment or medical equipment for life support.
4. Design your application so that the product is used within the ranges guaranteed by Hitachi particularly for maximum rating, operating supply voltage range, heat radiation characteristics, installation conditions and other characteristics. Hitachi bears no responsibility for failure or damage when used beyond the guaranteed ranges. Even within the guaranteed ranges, consider normally foreseeable failure rates or failure modes in semiconductor devices and employ systemic measures such as fail-safes, so that the equipment incorporating Hitachi product does not cause bodily injury, fire or other consequential damage due to operation of the Hitachi product.
5. This product is not designed to be radiation resistant.
6. No one is permitted to reproduce or duplicate, in any form, the whole or part of this document without written approval from Hitachi.
7. Contact Hitachi's sales office for any questions regarding this document or Hitachi semiconductor products.

HITACHI

Hitachi, Ltd.

Semiconductor & Integrated Circuits.

Nippon Bldg., 2-6-2, Ohite-machi, Chiyoda-ku, Tokyo 100-0004, Japan

Tel: Tokyo (03) 3270-2111 Fax: (03) 3270-5109

URL NorthAmerica : <http://semiconductor.hitachi.com/>
 Europe : <http://www.hitachi-eu.com/hel/ecg>
 Asia (Singapore) : <http://www.has.hitachi.com.sg/grp3/sicd/index.htm>
 Asia (Taiwan) : http://www.hitachi.com.tw/E/Product/SICD_Frame.htm
 Asia (HongKong) : <http://www.hitachi.com.hk/eng/bo/grp3/index.htm>
 Japan : <http://www.hitachi.co.jp/Sicd/indx.htm>

For further information write to:

Hitachi Semiconductor
 (America) Inc.
 179 East Tasman Drive,
 San Jose, CA 95134
 Tel: <1> (408) 433-1990
 Fax: <1> (408) 433-0223

Hitachi Europe GmbH
 Electronic components Group
 Dornacher Straße 3
 D-85622 Feldkirchen, Munich
 Germany
 Tel: <49> (89) 9 9180-0
 Fax: <49> (89) 9 29 30 00

Hitachi Europe Ltd.
 Electronic Components Group.
 Whitebrook Park
 Lower Cookham Road
 Maidenhead
 Berkshire SL6 8YA, United Kingdom
 Tel: <44> (1628) 585000
 Fax: <44> (1628) 778322

Hitachi Asia Pte. Ltd.
 16 Collyer Quay #20-00
 Hitachi Tower
 Singapore 049318
 Tel: 535-2100
 Fax: 535-1533

Hitachi Asia Ltd.
 Taipei Branch Office
 3F, Hung Kuo Building, No.167,
 Tun-Hwa North Road, Taipei (105)
 Tel: <886> (2) 2718-3666
 Fax: <886> (2) 2718-8180

Hitachi Asia (Hong Kong) Ltd.
 Group III (Electronic Components)
 7/F., North Tower, World Finance Centre,
 Harbour City, Canton Road, Tsim Sha Tsui,
 Kowloon, Hong Kong
 Tel: <852> (2) 735 9218
 Fax: <852> (2) 730 0281
 Telex: 40815 HITEC HX

Copyright ' Hitachi, Ltd., 1998. All rights reserved. Printed in Japan.

HITACHI



LittleDiode supplies new, hard to find or obsolete electronic components and semiconductors all over the world.

With over two million different components listed you are sure to find the part you need.

Feel free to visit us today at our online store:

LittleDiode.com

Looking forward to providing you with the best possible service.