

100V - 100W DMOS AUDIO AMPLIFIER WITH MUTE/ST-BY

- VERY HIGH OPERATING VOLTAGE RANGE ($\pm 40V$)
- DMOS POWER STAGE
- HIGH OUTPUT POWER (UP TO 100W MUSIC POWER)
- MUTING/STAND-BY FUNCTIONS
- NO SWITCH ON/OFF NOISE
- NO BOUCHEROT CELLS
- VERY LOW DISTORTION
- VERY LOW NOISE
- SHORT CIRCUIT PROTECTION
- THERMAL SHUTDOWN

MULTIPOWER BCD TECHNOLOGY

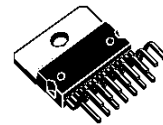

Multiwatt15

ORDERING NUMBER: TDA7294V

DESCRIPTION

The TDA7294 is a monolithic integrated circuit in Multiwatt15 package, intended for use as audio class AB amplifier in Hi-Fi field applications (Home Stereo, self powered loudspeakers, Top-class TV). Thanks to the wide voltage range and

to the high out current capability it is able to supply the highest power into both 4 Ω and 8 Ω loads even in presence of poor supply regulation, with high Supply Voltage Rejection.

The built in muting function with turn on delay simplifies the remote operation avoiding switching on-off noises.

Figure 1: Typical Application and Test Circuit

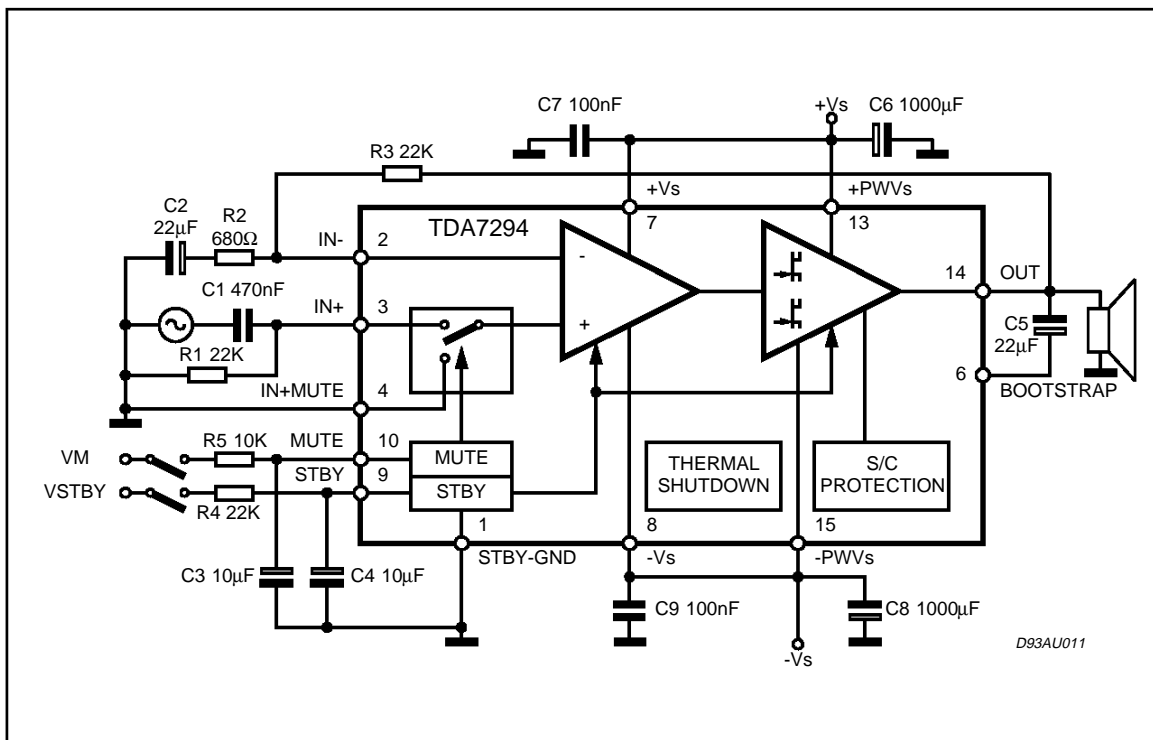

TDA7294

PIN CONNECTION (Top view)

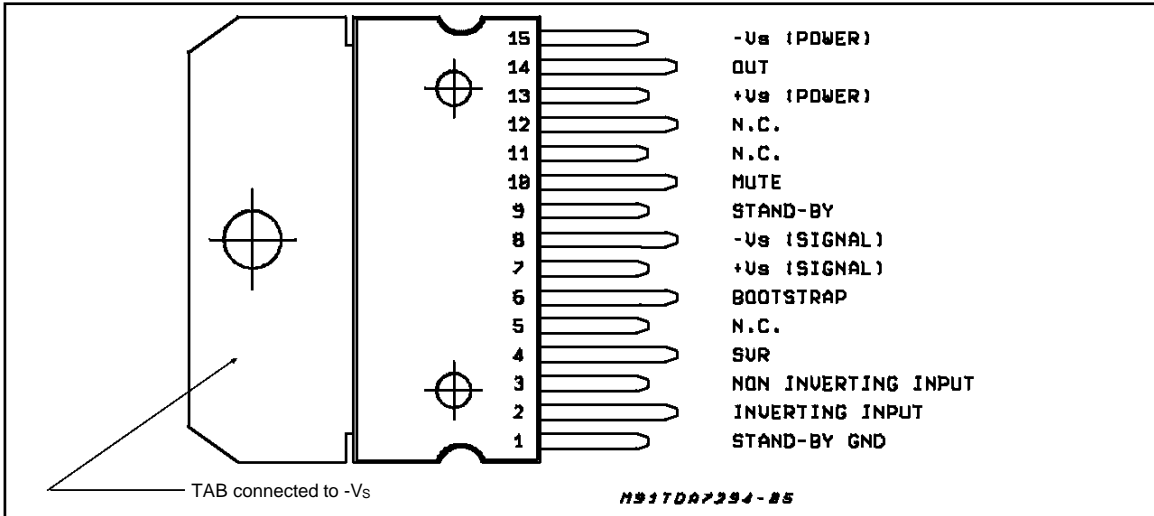

BLOCK DIAGRAM

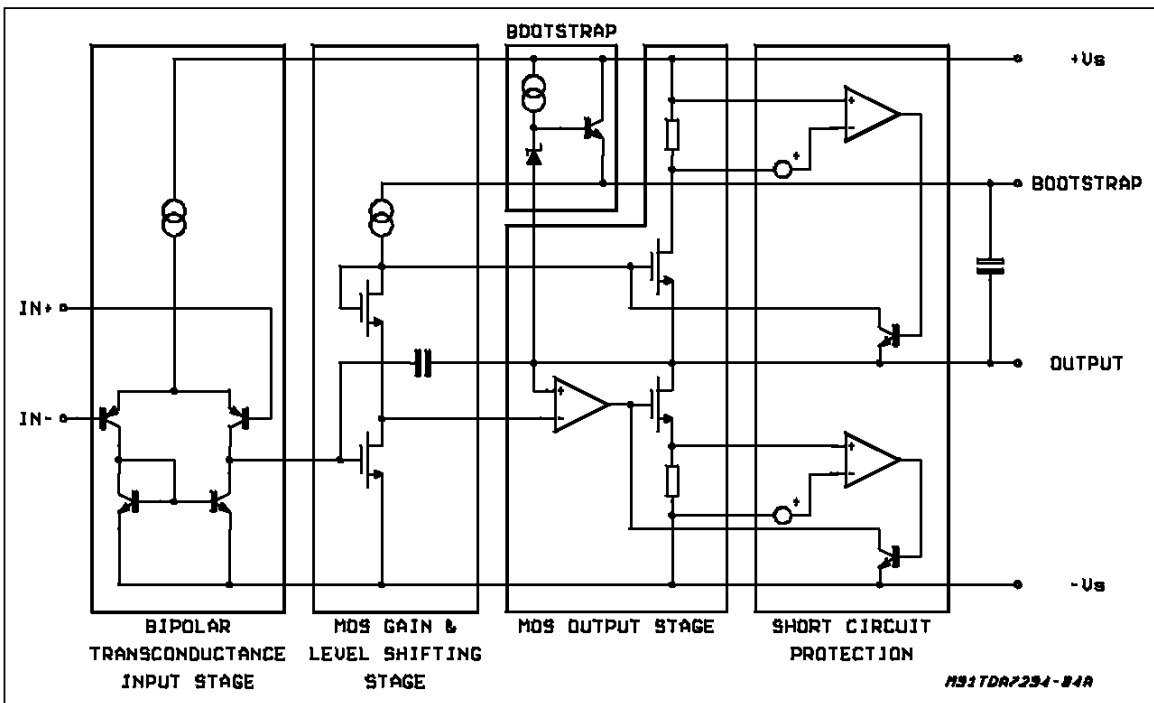

ABSOLUTE MAXIMUM RATINGS

Symbol	Parameter	Value	Unit
V_S	Supply Voltage (No Signal)	± 50	V
I_o	Output Peak Current	10	A
P_{tot}	Power Dissipation $T_{case} = 70^\circ\text{C}$	50	W
T_{op}	Operating Ambient Temperature Range	0 to 70	$^\circ\text{C}$
T_{stg}, T_j	Storage and Junction Temperature	150	$^\circ\text{C}$

THERMAL DATA

Symbol	Description	Value	Unit
$R_{th\ j-case}$	Thermal Resistance Junction-case	Max	1.5 °C/W

ELECTRICAL CHARACTERISTICS (Refer to the Test Circuit $V_S = \pm 35V$, $R_L = 8\Omega$, $G_V = 30dB$; $R_g = 50\Omega$; $T_{amb} = 25^\circ C$, $f = 1\ kHz$; unless otherwise specified.)

Symbol	Parameter	Test Condition	Min.	Typ.	Max.	Unit
V_S	Supply Range		± 10		± 40	V
I_q	Quiescent Current		20	30	60	mA
I_b	Input Bias Current				500	nA
V_{OS}	Input Offset Voltage				± 10	mV
I_{OS}	Input Offset Current				± 100	nA
P_O	RMS Continuous Output Power	$d = 0.5\%$: $V_S = \pm 35V$, $R_L = 8\Omega$ $V_S = \pm 31V$, $R_L = 6\Omega$ $V_S = \pm 27V$, $R_L = 4\Omega$	60 60 60	70 70 70		W W W
	Music Power (RMS) IEC268.3 RULES - $\Delta t = 1s$ (*)	$d = 10\%$ $R_L = 8\Omega$; $V_S = \pm 38V$ $R_L = 6\Omega$; $V_S = \pm 33V$ $R_L = 4\Omega$; $V_S = \pm 29V$ (***)		100 100 100		W W W
d	Total Harmonic Distortion (**)	$P_O = 5W$; $f = 1kHz$ $P_O = 0.1$ to $50W$; $f = 20Hz$ to $20kHz$		0.005	0.1	% %
		$V_S = \pm 27V$, $R_L = 4\Omega$: $P_O = 5W$; $f = 1kHz$ $P_O = 0.1$ to $50W$; $f = 20Hz$ to $20kHz$		0.01	0.1	% %
SR	Slew Rate		7	10		V/ μs
G_V	Open Loop Voltage Gain			80		dB
G_V	Closed Loop Voltage Gain		24	30	40	dB
e_N	Total Input Noise	A = curve $f = 20Hz$ to $20kHz$		1 2	5	μV μV
f_L, f_H	Frequency Response (-3dB)	$P_O = 1W$	20Hz to 20kHz			
R_i	Input Resistance		100			k Ω
SVR	Supply Voltage Rejection	$f = 100Hz$; $V_{ripple} = 0.5V_{rms}$	60	75		dB
T_S	Thermal Shutdown			145		°C
STAND-BY FUNCTION (Ref: -V_S or GND)						
$V_{ST\ on}$	Stand-by on Threshold				1.5	V
$V_{ST\ off}$	Stand-by off Threshold		3.5			V
ATT_{st-by}	Stand-by Attenuation		70	90		dB
$I_{q\ st-by}$	Quiescent Current @ Stand-by			1	3	mA
MUTE FUNCTION (Ref: -V_S or GND)						
V_{Mon}	Mute on Threshold				1.5	V
V_{Moff}	Mute off Threshold		3.5			V
ATT_{mute}	Mute Attenuation		60	80		dB

Note (*):

MUSIC POWER CONCEPT

MUSIC POWER is the maximal power which the amplifier is capable of producing across the rated load resistance (regardless of non linearity) 1 sec after the application of a sinusoidal input signal of frequency 1kHz.

Note ():** Tested with optimized Application Board (see fig. 2)

Note (*):** Limited by the max. allowable current.

Figure 2: P.C.B. and components layout of the circuit of figure 1. (1:1 scale)

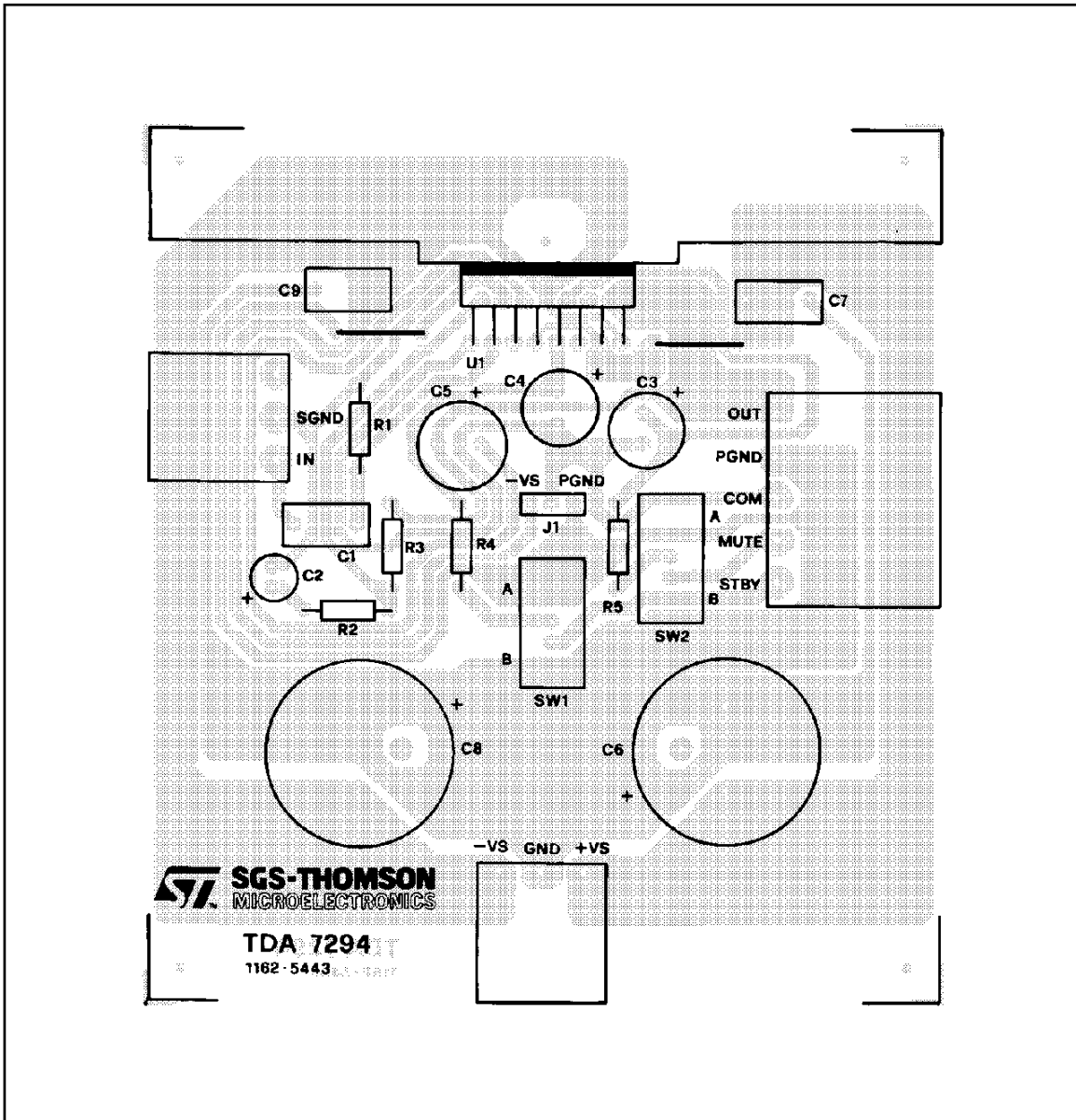

Note:

The Stand-by and Mute functions can be referred either to GND or -VS.
 On the P.C.B. is possible to set both the configuration through the jumper J1.

APPLICATION SUGGESTIONS (see Test and Application Circuits of the Fig. 1)

The recommended values of the external components are those shown on the application circuit of Figure 1. Different values can be used; the following table can help the designer.

COMPONENTS	SUGGESTED VALUE	PURPOSE	LARGER THAN SUGGESTED	SMALLER THAN SUGGESTED
R1 (*)	22k	INPUT RESISTANCE	INCREASE INPUT IMPEDANCE	DECREASE INPUT IMPEDANCE
R2	680Ω	CLOSED LOOP GAIN SET TO 30dB (**)	DECREASE OF GAIN	INCREASE OF GAIN
R3 (*)	22k		INCREASE OF GAIN	DECREASE OF GAIN
R4	22k	ST-BY TIME CONSTANT	LARGER ST-BY ON/OFF TIME	SMALLER ST-BY ON/OFF TIME; POP NOISE
R5	10k	MUTE TIME CONSTANT	LARGER MUTE ON/OFF TIME	SMALLER MUTE ON/OFF TIME
C1	0.47μF	INPUT DC DECOUPLING		HIGHER LOW FREQUENCY CUTOFF
C2	22μF	FEEDBACK DC DECOUPLING		HIGHER LOW FREQUENCY CUTOFF
C3	10μF	MUTE TIME CONSTANT	LARGER MUTE ON/OFF TIME	SMALLER MUTE ON/OFF TIME
C4	10μF	ST-BY TIME CONSTANT	LARGER ST-BY ON/OFF TIME	SMALLER ST-BY ON/OFF TIME; POP NOISE
C5	22μF	BOOTSTRAPPING		SIGNAL DEGRADATION AT LOW FREQUENCY
C6, C8	1000μF	SUPPLY VOLTAGE BYPASS		DANGER OF OSCILLATION
C7, C9	0.1μF	SUPPLY VOLTAGE BYPASS		DANGER OF OSCILLATION

(*) R1 = R3 FOR POP OPTIMIZATION

(**) CLOSED LOOP GAIN HAS TO BE ≥ 24 dB

TYPICAL CHARACTERISTICS

(Application Circuit of fig 1 unless otherwise specified)

Figure 3: Output Power vs. Supply Voltage.

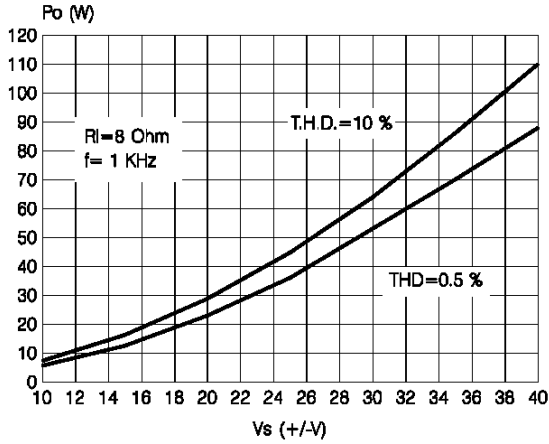

Figure 4: Distortion vs. Output Power

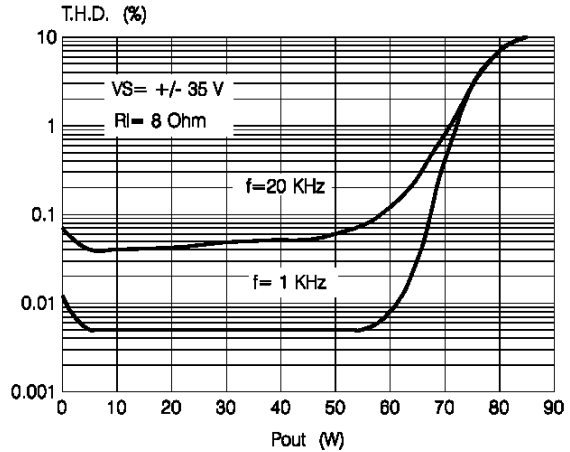

Figure 5: Output Power vs. Supply Voltage

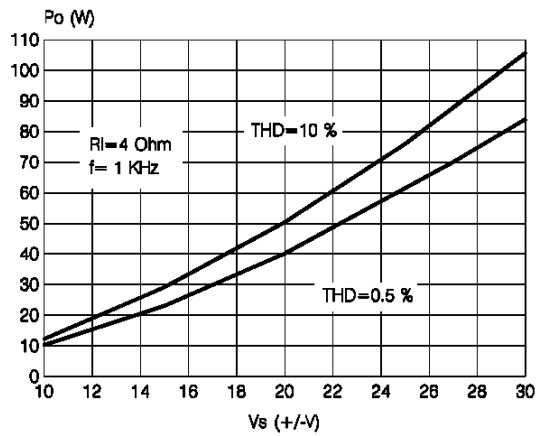

Figure 6: Distortion vs. Output Power

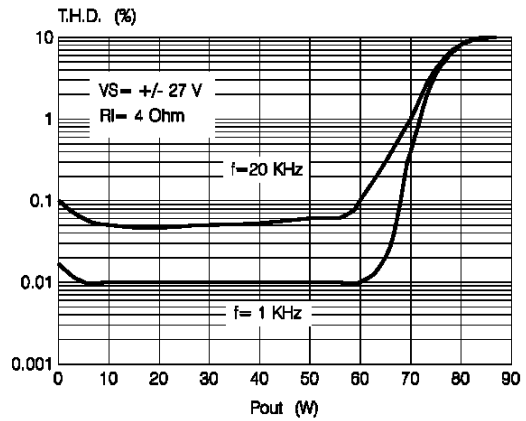

Figure 7: Distortion vs. Frequency

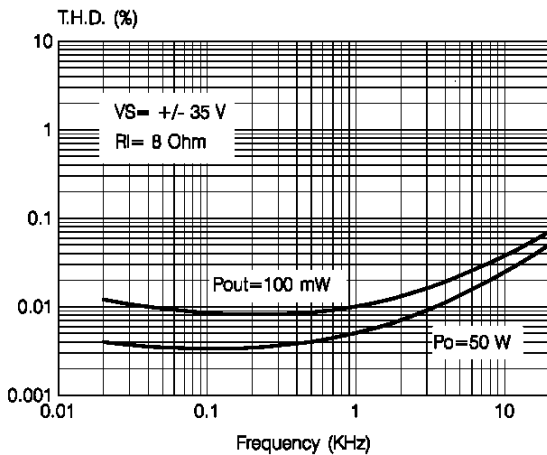
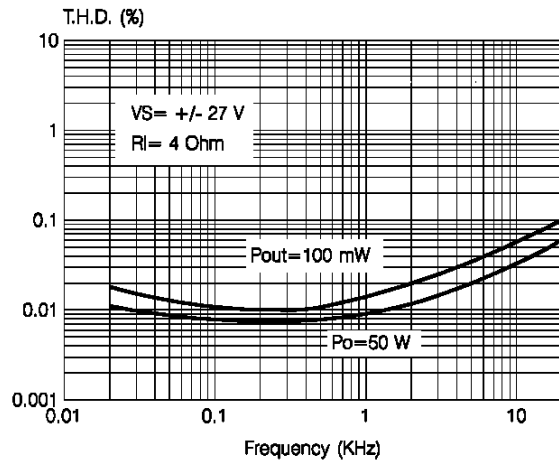

Figure 8: Distortion vs. Frequency



TYPICAL CHARACTERISTICS (continued)

Figure 9: Quiescent Current vs. Supply Voltage

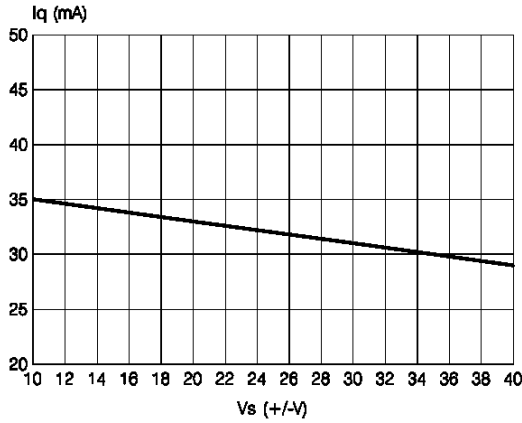

Figure 10: Supply Voltage Rejection vs. Frequency

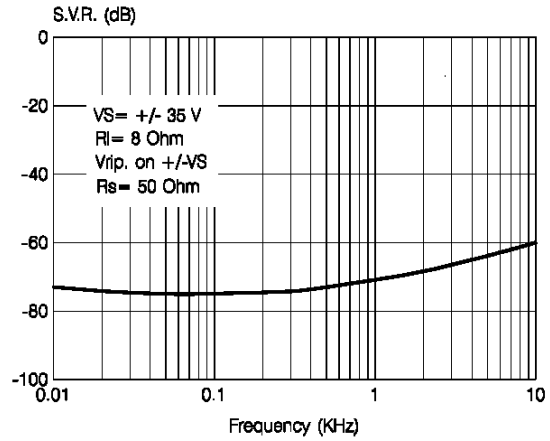

Figure 11: Mute Attenuation vs. V_{pin10}

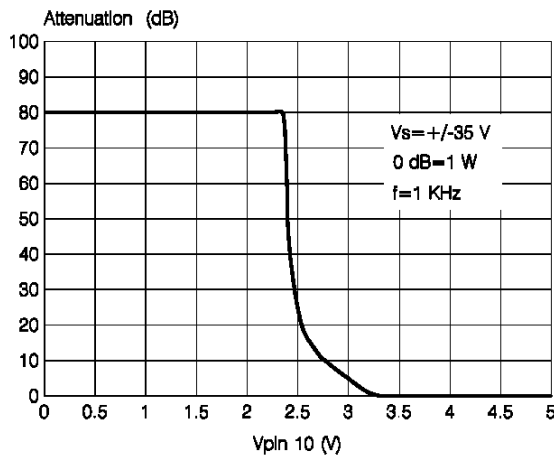

Figure 12: St-by Attenuation vs. V_{pin9}

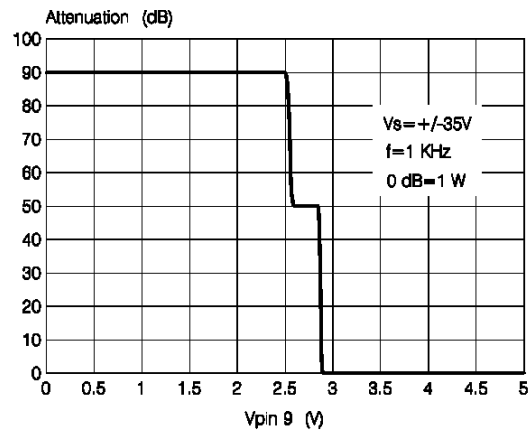

Figure 13: Power Dissipation vs. Output Power

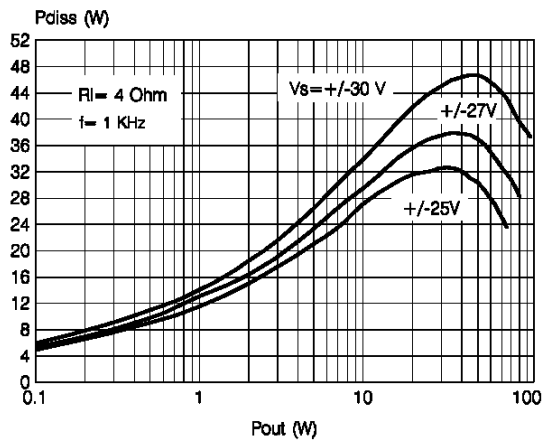

Figure 14: Power Dissipation vs. Output Power

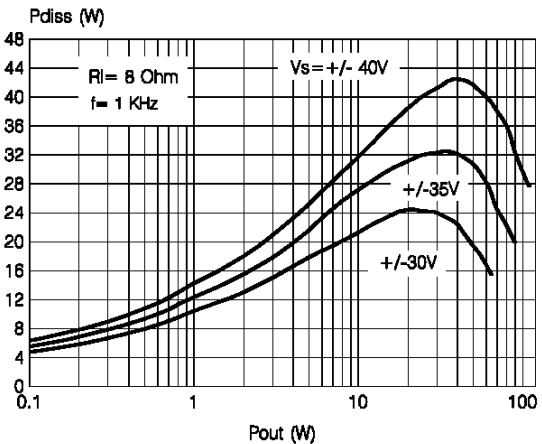
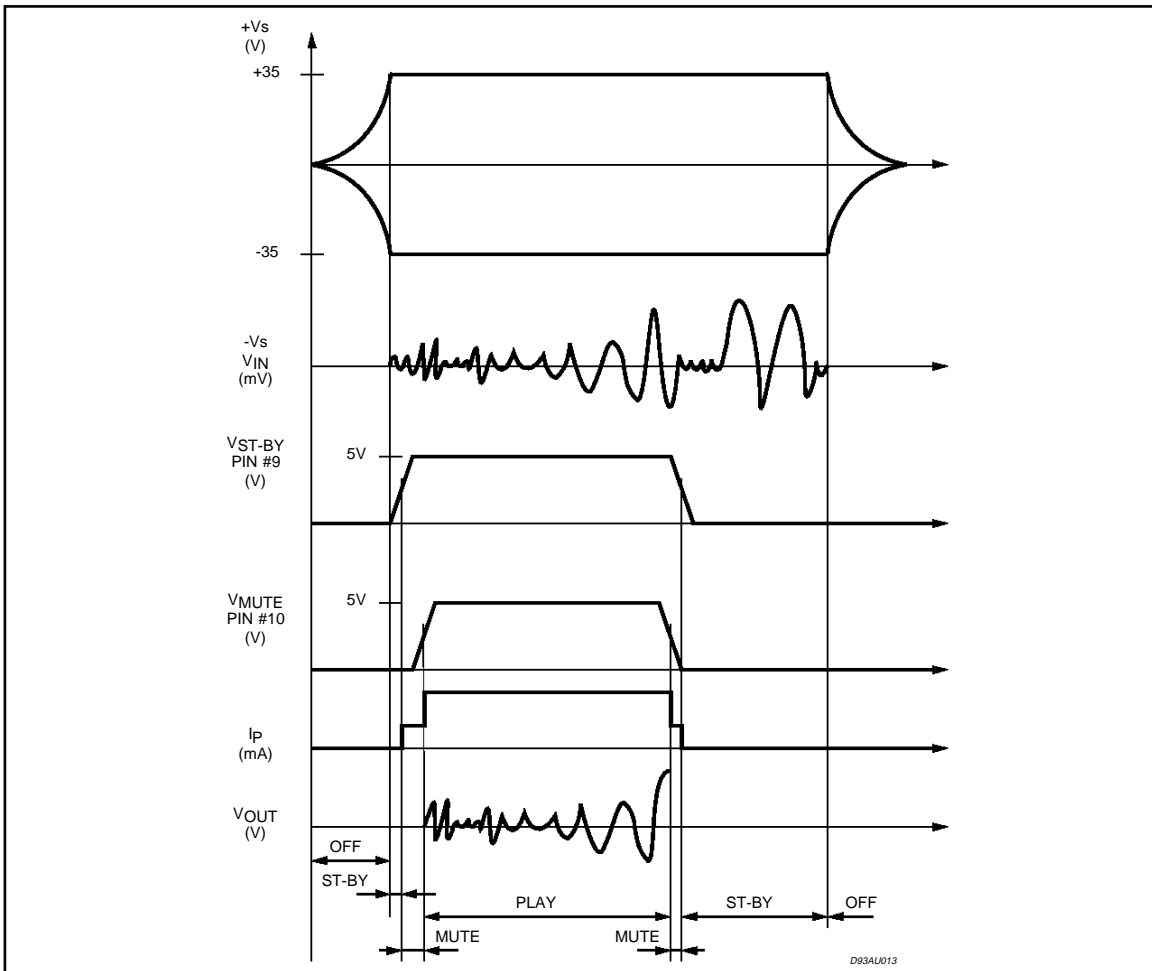

Figure 16: Turn ON/OFF Suggested Sequence



In addition to the overload protection described above, the device features a thermal shutdown circuit which initially puts the device into a muting state (@ $T_j = 145^\circ\text{C}$) and then into stand-by (@

$T_j = 150^\circ\text{C}$).

Full protection against electrostatic discharges on every pin is included.

Figure 17: Single Signal ST-BY/MUTE Control Circuit

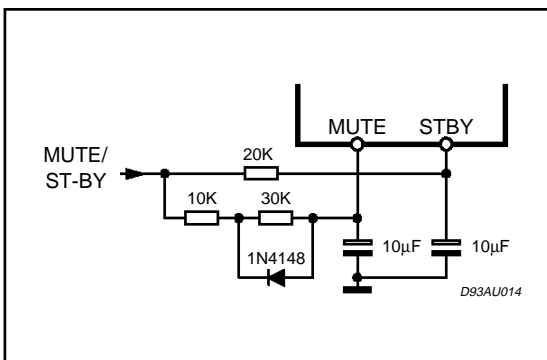

3) Other Features

The device is provided with both stand-by and mute functions, independently driven by two CMOS logic compatible input pins.

The circuits dedicated to the switching on and off of the amplifier have been carefully optimized to avoid any kind of uncontrolled audible transient at the output.

The sequence that we recommend during the ON/OFF transients is shown by Figure 16.

The application of figure 17 shows the possibility of using only one command for both st-by and mute functions. On both the pins, the maximum applicable range corresponds to the operating supply voltage.

APPLICATION INFORMATION

HIGH-EFFICIENCY

Constraints of implementing high power solutions are the power dissipation and the size of the power supply. These are both due to the low efficiency of conventional AB class amplifier approaches.

Here below (figure 18) is described a circuit proposal for a high efficiency amplifier which can be adopted for both HI-FI and CAR-RADIO applications.

The TDA7294 is a monolithic MOS power amplifier which can be operated at 80V supply voltage (100V with no signal applied) while delivering output currents up to ± 10 A.

This allows the use of this device as a very high power amplifier (up to 180W as peak power with T.H.D.=10 % and $R_L = 4$ Ohm); the only drawback is the power dissipation, hardly manageable in the above power range.

Figure 20 shows the power dissipation versus output power curve for a class AB amplifier, compared with a high efficiency one.

In order to dimension the heatsink (and the power supply), a generally used average output power value is one tenth of the maximum output power at T.H.D.=10 %.

From fig. 20, where the maximum power is around 200 W, we get an average of 20 W, in this condition, for a class AB amplifier the average power dissipation is equal to 65 W.

The typical junction-to-case thermal resistance of the TDA7294 is 1°C/W (max= 1.5°C/W). To avoid that, in worst case conditions, the chip temperature exceeds 150°C , the thermal resistance of the heatsink must be 0.038°C/W (@ max ambient temperature of 50°C).

As the above value is practically unreachable; a high efficiency system is needed in those cases where the continuous RMS output power is higher than 50-60 W.

The TDA7294 was designed to work also in higher efficiency way.

For this reason there are four power supply pins: two intended for the signal part and two for the power part.

T1 and T2 are two power transistors that only operate when the output power reaches a certain threshold (e.g. 20 W). If the output power increases, these transistors are switched on during the portion of the signal where more output voltage swing is needed, thus "bootstrapping" the power supply pins (#13 and #15).

The current generators formed by T4, T7, zener

Figure 18: High Efficiency Application Circuit

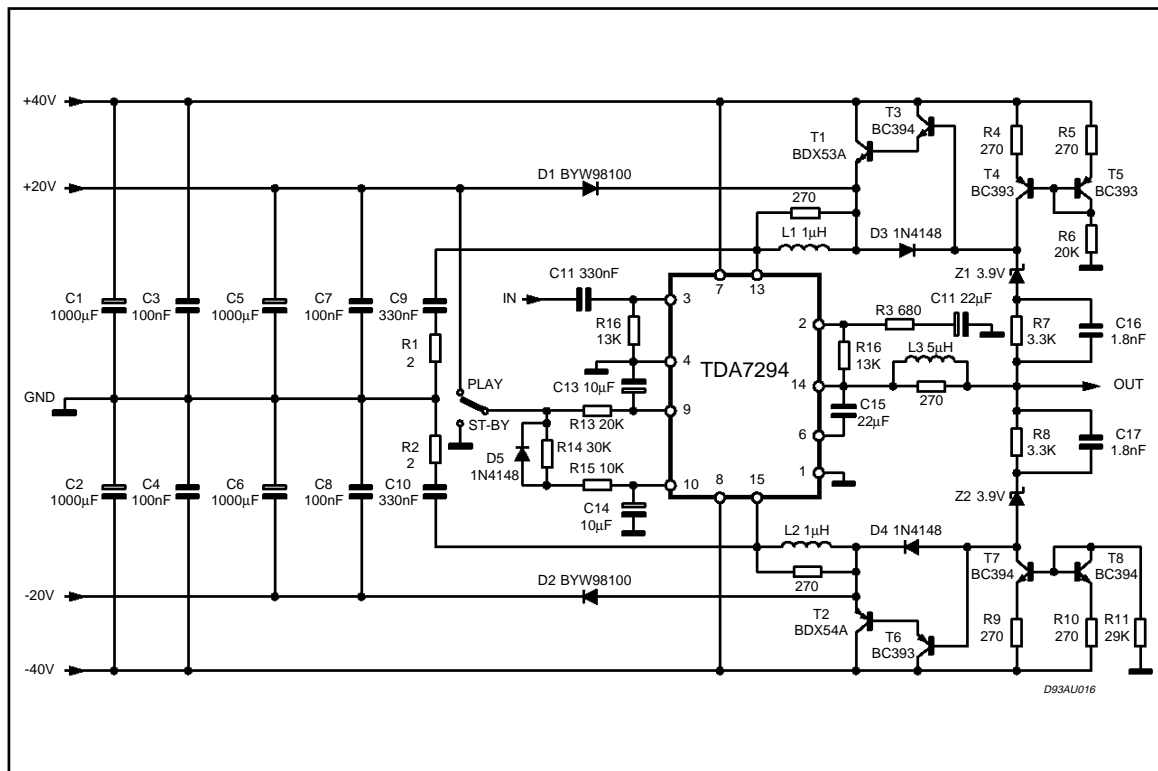
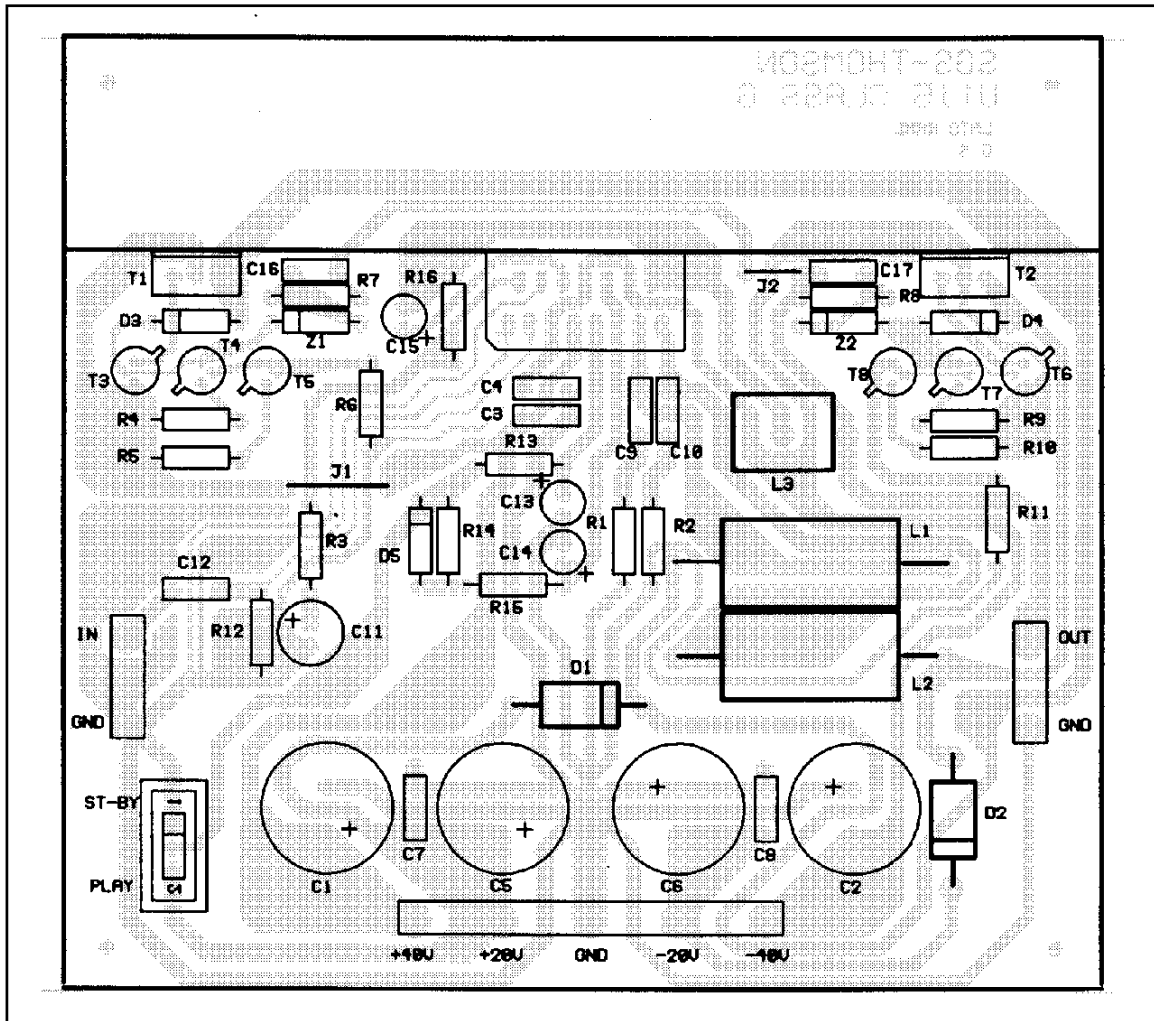

Figure 19: P.C.B. and Components Layout of the Circuit of figure 18 (1:1 scale)



diodes Z1,Z2 and resistors R7,R8 define the minimum drop across the power MOS transistors of the TDA7294. L1, L2, L3 and the snubbers C9, R1 and C10, R2 stabilize the loops formed by the "bootstrap" circuits and the output stage of the TDA7294.

In figures 21,22 the performances of the system in terms of distortion and output power at various frequencies (measured on PCB shown in fig. 19) are displayed.

The output power that the TDA7294 in high-efficiency application is able to supply at $V_s = +40V/+20V/-20V/-40V$; $f = 1$ KHz is:

- **Pout = 150 W @ T.H.D.=10 % with $R_l = 4$ Ohm**
- **Pout = 120 W @ " = 1% " " "**
- **Pout = 100 W @ " =10 % with $R_l = 8$ Ohm**
- **Pout = 80 W @ " = 1% " " "**

Results from efficiency measurements (4 and 8 Ohm loads, $V_s = \pm 40V$) are shown by figures 23 and 24. We have 3 curves: total power dissipation, power dissipation of the TDA7294 and power dissipation of the darlington.

By considering again a maximum average output power (music signal) of 20W, in case of the high efficiency application, the thermal resistance value needed from the heatsink is $2.2^\circ C/W$ ($V_s = \pm 40 V$ and $R_l = 4$ Ohm).

All components (TDA7294 and power transistors T1 and T2) can be placed on a $1.5^\circ C/W$ heatsink, with the power darlington electrically insulated from the heatsink.

Since the total power dissipation is less than that of a usual class AB amplifier, additional cost savings can be obtained while optimizing the power supply, even with a high headroom.

Figure 20: Power Dissipation vs. Output Power

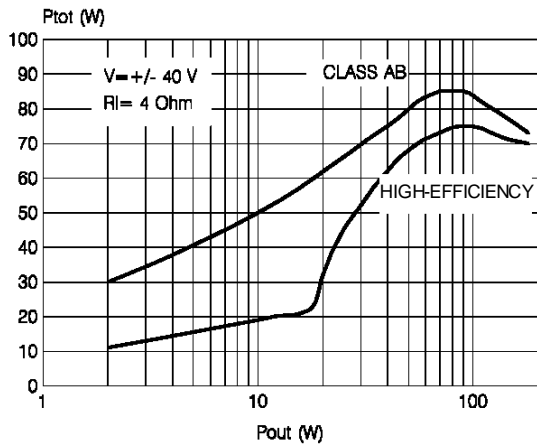

Figure 21: Distortion vs. Output Power

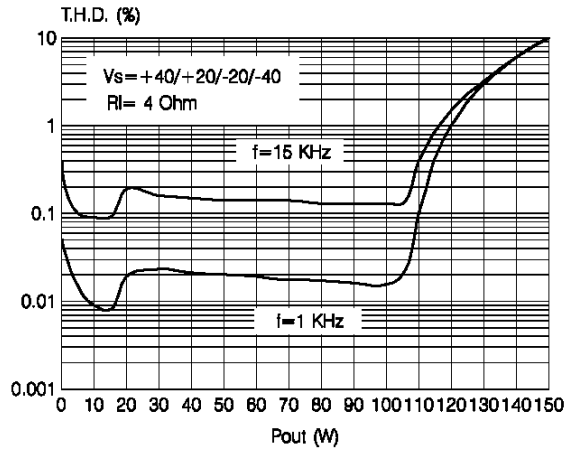

Figure 22: Distortion vs. Output Power

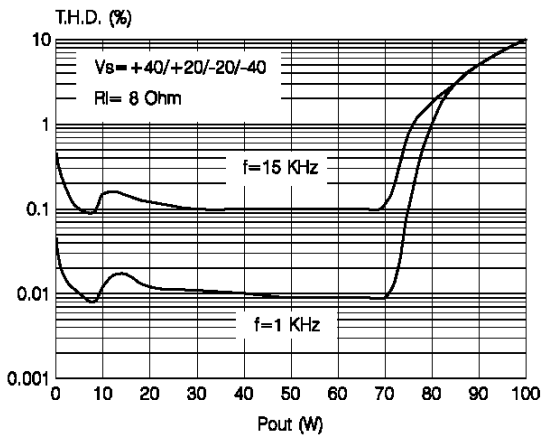

Figure 23: Power Dissipation vs. Output Power

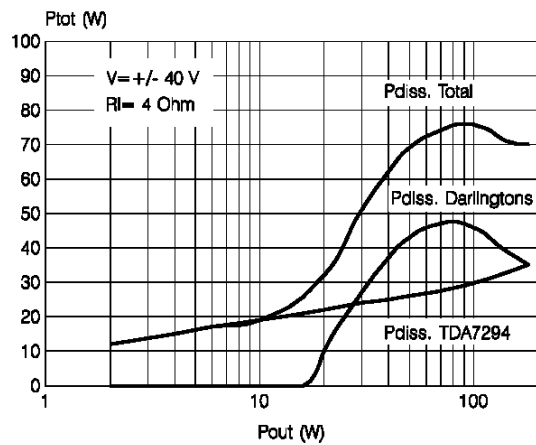
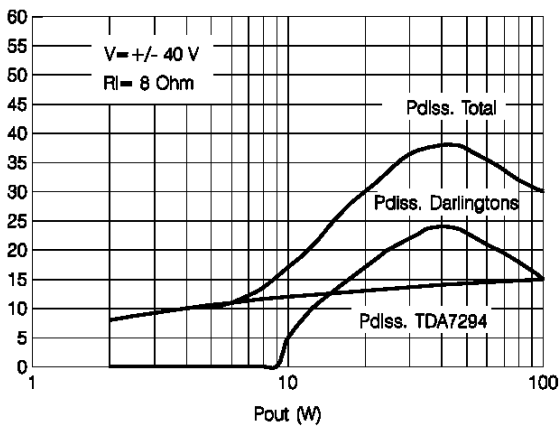

Figure 24: Power Dissipation vs. Output Power



BRIDGE APPLICATION

Another application suggestion is the BRIDGE configuration, where two TDA7294 are used, as shown by the schematic diagram of figure 25.

In this application, the value of the load must not be lower than 8 Ohm for dissipation and current capability reasons.

A suitable field of application includes HI-FI/TV subwoofers realizations.

The main advantages offered by this solution are:

- High power performances with limited supply voltage level.
- Considerably high output power even with high load values (i.e. 16 Ohm).

The characteristics shown by figures 27 and 28, measured with loads respectively 8 Ohm and 16 Ohm.

With $R_L = 8 \text{ Ohm}$, $V_s = \pm 25\text{V}$ the maximum output power obtainable is 150 W, while with $R_L = 16 \text{ Ohm}$, $V_s = \pm 35\text{V}$ the maximum Pout is 170 W.

Figure 25: Bridge Application Circuit

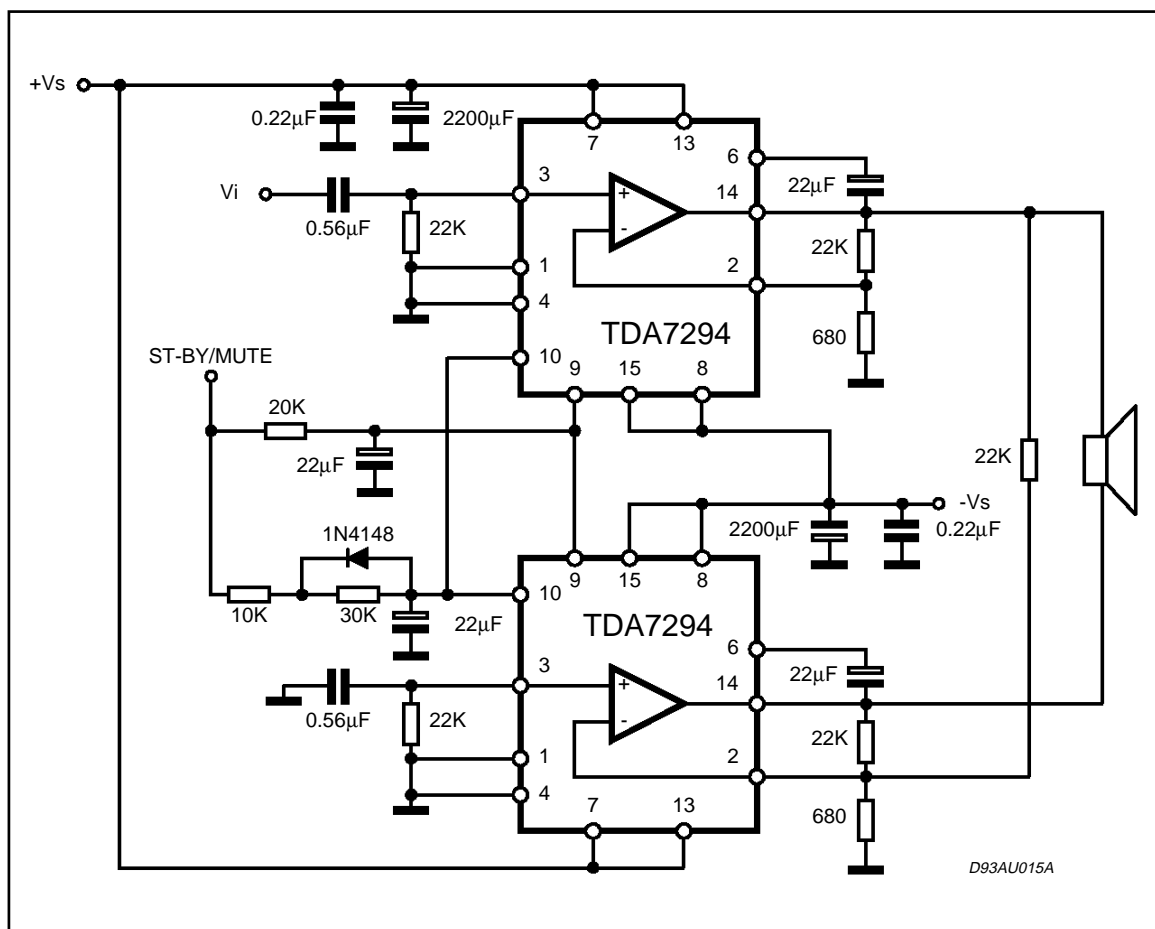

Figure 26: Frequency Response of the Bridge Application

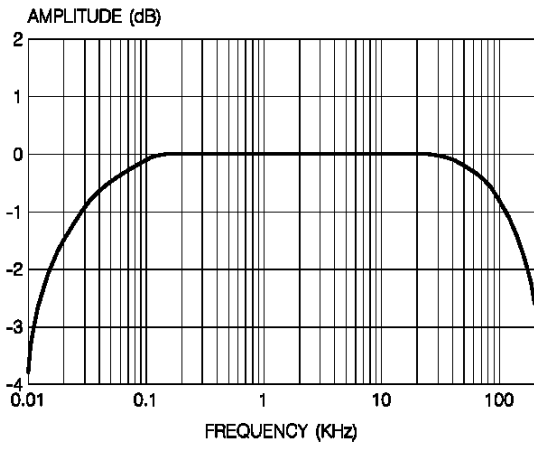

Figure 27: Distortion vs. Output Power

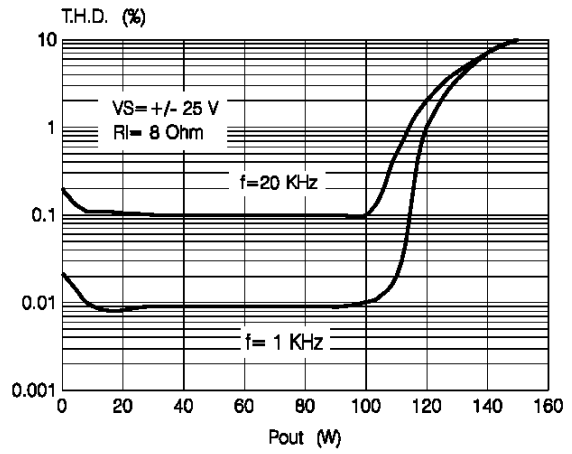
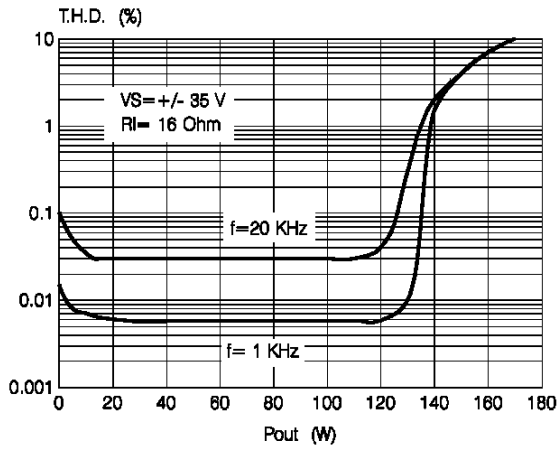
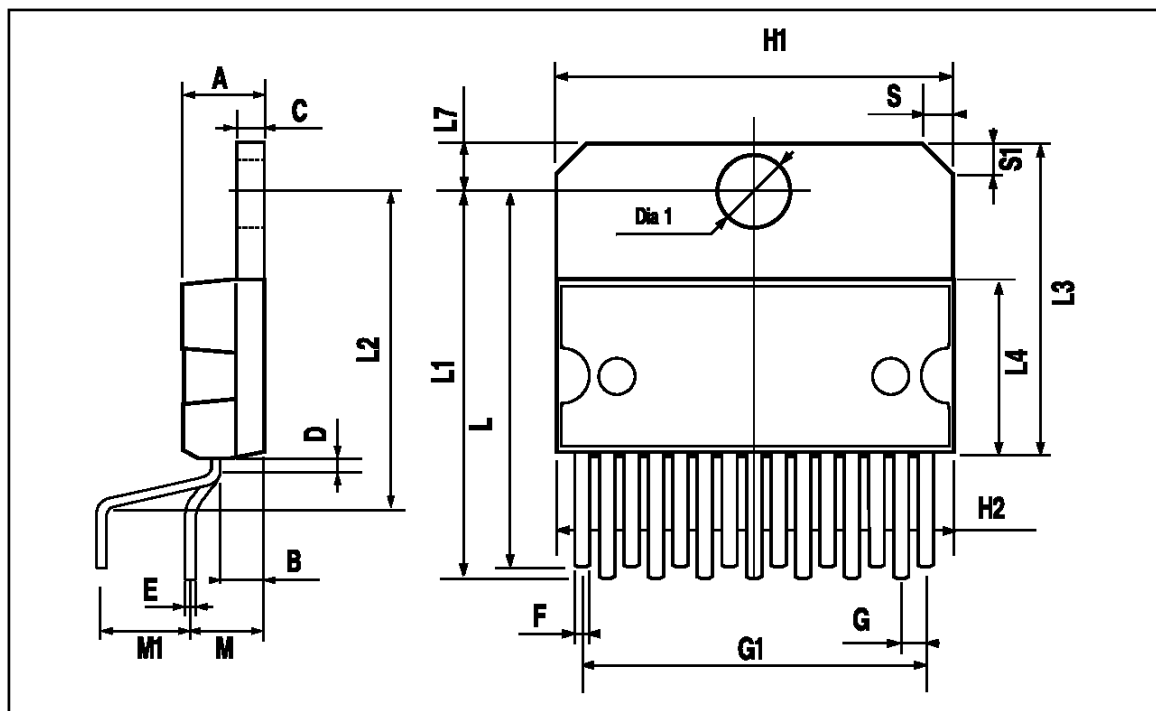

Figure 28: Distortion vs. Output Power



MULTIWATT15 PACKAGE MECHANICAL DATA (Vertical)

DIM.	mm			inch		
	MIN.	TYP.	MAX.	MIN.	TYP.	MAX.
A			5			0.197
B			2.65			0.104
C			1.6			0.063
D		1			0.039	
E	0.49		0.55	0.019		0.022
F	0.66		0.75	0.026		0.030
G	1.14	1.27	1.4	0.045	0.050	0.055
G1	17.57	17.78	17.91	0.692	0.700	0.705
H1	19.6			0.772		
H2			20.2			0.795
L	22.1		22.6	0.870		0.890
L1	22		22.5	0.866		0.886
L2	17.65		18.1	0.695		0.713
L3	17.25	17.5	17.75	0.679	0.689	0.699
L4	10.3	10.7	10.9	0.406	0.421	0.429
L7	2.65		2.9	0.104		0.114
M	4.2	4.3	4.6	0.165	0.169	0.181
M1	4.5	5.08	5.3	0.177	0.200	0.209
S	1.9		2.6	0.075		0.102
S1	1.9		2.6	0.075		0.102
Dia1	3.65		3.85	0.144		0.152



Information furnished is believed to be accurate and reliable. However, SGS-THOMSON Microelectronics assumes no responsibility for the consequences of use of such information nor for any infringement of patents or other rights of third parties which may result from its use. No license is granted by implication or otherwise under any patent or patent rights of SGS-THOMSON Microelectronics. Specifications mentioned in this publication are subject to change without notice. This publication supersedes and replaces all information previously supplied. SGS-THOMSON Microelectronics products are not authorized for use as critical components in life support devices or systems without express written approval of SGS-THOMSON Microelectronics.

© 1996 SGS-THOMSON Microelectronics All Rights Reserved

SGS-THOMSON Microelectronics GROUP OF COMPANIES

Australia - Brazil - France - Germany - Hong Kong - Italy - Japan - Korea - Malaysia - Malta - Morocco - The Netherlands - Singapore - Spain - Sweden - Switzerland - Taiwan - Thailand - United Kingdom - U.S.A.