

## CD4029BM/CD4029BC Presettable Binary/Decade Up/Down Counter

### General Description

The CD4029BM/CD4029BC is a presettable up/down counter which counts in either binary or decade mode depending on the voltage level applied at binary/decade input. When binary/decade is at logical "1", the counter counts in binary, otherwise it counts in decade. Similarly, the counter counts up when the up/down input is at logical "1" and vice versa.

A logical "1" preset enable signal allows information at the "jam" inputs to preset the counter to any state asynchronously with the clock. The counter is advanced one count at the positive-going edge of the clock if the carry in and preset enable inputs are at logical "0". Advancement is inhibited when either or both of these two inputs is at logical "1". The carry out signal is normally at logical "1" state and goes to logical "0" state when the counter reaches its maximum

count in the "up" mode or the minimum count in the "down" mode provided the carry input is at logical "0" state.

All inputs are protected against static discharge by diode clamps to both  $V_{DD}$  and  $V_{SS}$ .

### Features

- Wide supply voltage range 3V to 15V
- High noise immunity 0.45  $V_{DD}$  (typ.)
- Low power fan out of 2 driving 74L or 1 driving 74LS
- TTL compatibility
- Parallel jam inputs
- Binary or BCD decade up/down counting

### Logic Diagram

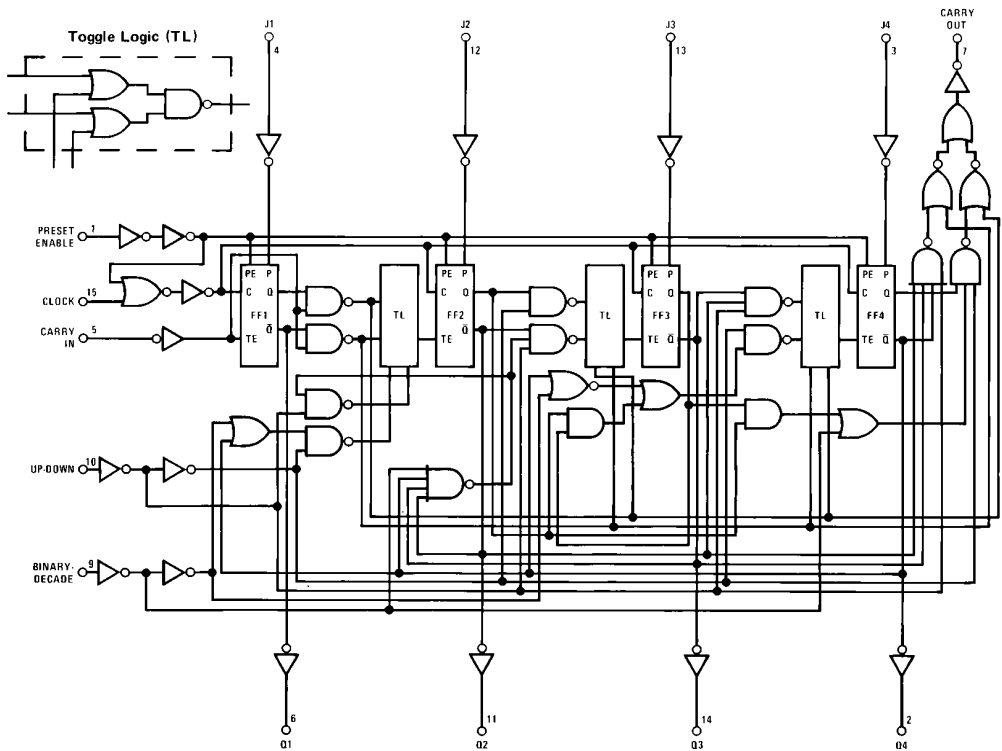

TL/F/5960-1

## Absolute Maximum Ratings

(Notes 1 and 2)

If Military/Aerospace specified devices are required, please contact the National Semiconductor Sales Office/Distributors for availability and specifications.

DC Supply Voltage ( $V_{DD}$ )	-0.5V to +18 $V_{DC}$
Input Voltage ( $V_{IN}$ )	-0.5V to $V_{DD}$ + 0.5 $V_{DC}$
Storage Temperature Range ( $T_S$ )	-65°C to +150°C
Power Dissipation ( $P_D$ )	
Dual-In-Line	700 mW
Small Outline	500 mW
Lead Temperature ( $T_L$ )	
(Soldering, 10 seconds)	260°C

## Recommended Operating Conditions

(Note 2)

DC Supply Voltage ( $V_{DD}$ )	3V to 15 $V_{DC}$
Input Voltage ( $V_{IN}$ )	0V to $V_{DD}$ $V_{DC}$
Operating Temperature Range ( $T_A$ )	
CD4029BM	-55°C to +125°C
CD4029BC	-40°C to +85°C

## DC Electrical Characteristics CD4029BM (Note 2)

Symbol	Parameter	Conditions	-55°C		+25°C			+125°C		Units
			Min	Max	Min	Typ	Max	Min	Max	
$I_{DD}$	Quiescent Device Current	$V_{DD} = 5V$		5			5	5	150	$\mu A$
		$V_{DD} = 10V$		10			10		300	$\mu A$
		$V_{DD} = 15V$		20			20		600	$\mu A$
$V_{OL}$	Low Level Output Voltage	$ I_O  < 1 \mu A$								
		$V_{DD} = 5V$		0.05		0	0.05		0.05	V
		$V_{DD} = 10V$		0.05		0	0.05		0.05	V
$V_{OH}$	High Level Output Voltage	$ I_O  < 1 \mu A$								
		$V_{DD} = 5V$	4.95		4.95	5		4.95		V
		$V_{DD} = 10V$	9.95		9.95	10		9.95		V
$V_{IL}$	Low Level Input Voltage	$V_{DD} = 5V, V_O = 0.5V$ or 4.5V		1.5			1.5		1.5	V
		$V_{DD} = 10V, V_O = 1V$ or 9V		3.0			3.0		3.0	V
		$V_{DD} = 15V, V_O = 1.5V$ or 13.5V		4.0			4.0		4.0	V
$V_{IH}$	High Level Input Voltage	$V_{DD} = 5V, V_O = 0.5V$ or 4.5V	3.5		3.5			3.5		V
		$V_{DD} = 10V, V_O = 1V$ or 9V	7.0		7.0			7.0		V
		$V_{DD} = 15V, V_O = 1.5V$ or 13.5V	11.0		11.0			11.0		V
$I_{OL}$	Low Level Output Current (Note 3)	$V_{DD} = 5V, V_O = 0.4V$	0.64		0.51	0.88		0.36		mA
		$V_{DD} = 10V, V_O = 0.5V$	1.6		1.3	2.25		0.9		mA
		$V_{DD} = 15V, V_O = 1.5V$	4.2		3.4	8.8		2.4		mA
$I_{OH}$	High Level Output Current (Note 3)	$V_{DD} = 5V, V_O = 4.6V$	-0.64		-0.51	-0.88		-0.36		mA
		$V_{DD} = 10V, V_O = 9.5V$	-1.6		-1.3	-2.25		-0.9		mA
		$V_{DD} = 15V, V_O = 13.5V$	-4.2		-3.4	-8.8		-2.4		mA
$I_{IN}$	Input Current	$V_{DD} = 15V, V_{IN} = 0V$		-0.1		$-10^{-5}$	-0.1		-1.0	$\mu A$
		$V_{DD} = 15V, V_{IN} = 15V$		0.1		$10^{-5}$	0.1		1.0	$\mu A$

## DC Electrical Characteristics CD4029BC (Note 2)

Symbol	Parameter	Conditions	-40°C		+25°C			+85°C		Units
			Min	Max	Min	Typ	Max	Min	Max	
$I_{DD}$	Quiescent Device Current	$V_{DD} = 5V$		20			20		150	$\mu A$
		$V_{DD} = 10V$		40			40		300	$\mu A$
		$V_{DD} = 15V$		80			80		600	$\mu A$
$V_{OL}$	Low Level Output Voltage	$ I_O  < 1 \mu A$								
		$V_{DD} = 5V$		0.05		0	0.05		0.05	V
		$V_{DD} = 10V$		0.05		0	0.05		0.05	V
$V_{OH}$	High Level Output Voltage	$ I_O  < 1 \mu A$								
		$V_{DD} = 5V$	4.95		4.95	5		4.95		V
		$V_{DD} = 10V$	9.95		9.95	10		9.95		V
$V_{OH}$	High Level Output Voltage	$V_{DD} = 15V$	14.95		14.95	15		14.95		V

**Note 1:** "Absolute Maximum Ratings" are those values beyond which the safety of the device cannot be guaranteed. Except for "Operating Temperature Range" they are not meant to imply that the devices should be operated at these limits. The table of "Electrical Characteristics" provides conditions for actual device operation.

**Note 2:**  $V_{SS} = 0V$  unless otherwise specified.

**Note 3:**  $I_{OH}$  and  $I_{OL}$  are tested one output at a time.

## DC Electrical Characteristics CD4029BC (Note 2) (Continued)

Symbol	Parameter	Conditions	-40°C		+25°C			+85°C		Units
			Min	Max	Min	Typ	Max	Min	Max	
V <sub>IL</sub>	Low Level Input Voltage	V <sub>DD</sub> = 5V, V <sub>O</sub> = 0.5V or 4.5V		1.5			1.5		1.5	V
		V <sub>DD</sub> = 10V, V <sub>O</sub> = 1V or 9V		3.0			3.0		3.0	V
		V <sub>DD</sub> = 15V, V <sub>O</sub> = 1.5V or 13.5V		4.0			4.0		4.0	V
V <sub>IH</sub>	High Level Input Voltage	V <sub>DD</sub> = 5V, V <sub>O</sub> = 0.5V or 4.5V	3.5		3.5			3.5		V
		V <sub>DD</sub> = 10V, V <sub>O</sub> = 1V or 9V	7.0		7.0			7.0		V
		V <sub>DD</sub> = 15V, V <sub>O</sub> = 1.5V or 13.5V	11.0		11.0			11.0		V
I <sub>OL</sub>	Low Level Output Current (Note 3)	V <sub>DD</sub> = 5V, V <sub>O</sub> = 0.4V	0.52		0.44	0.88		0.36		mA
		V <sub>DD</sub> = 10V, V <sub>O</sub> = 0.5V	1.3		1.1	2.25		0.9		mA
		V <sub>DD</sub> = 15V, V <sub>O</sub> = 1.5V	3.6		3.0	8.8		2.4		mA
I <sub>OH</sub>	High Level Output Current (Note 3)	V <sub>DD</sub> = 5V, V <sub>O</sub> = 4.6V	-0.52		-0.44	-0.88		-0.36		mA
		V <sub>DD</sub> = 10V, V <sub>O</sub> = 9.5V	-1.3		-1.1	-2.25		-0.9		mA
		V <sub>DD</sub> = 15V, V <sub>O</sub> = 13.5V	-3.6		-3.0	-8.8		-2.4		mA
I <sub>IN</sub>	Input Current	V <sub>DD</sub> = 15V, V <sub>IN</sub> = 0V V <sub>DD</sub> = 15V, V <sub>IN</sub> = 15V		-0.3 0.3		-10 <sup>-5</sup> 10 <sup>-5</sup>	-0.3 0.3		-1.0 1.0	μA μA

## AC Electrical Characteristics\*

T<sub>A</sub> = 25°C, C<sub>L</sub> = 50 pF, R<sub>L</sub> = 200k, Input t<sub>rCL</sub> = t<sub>fCL</sub> = 20 ns, unless otherwise specified

Symbol	Parameter	Conditions	Min	Typ	Max	Units		
<b>CLOCKED OPERATION</b>								
t <sub>PHL</sub> or t <sub>PLH</sub>	Propagation Delay Time to Q Outputs	V <sub>DD</sub> = 5V		200	400	ns		
		V <sub>DD</sub> = 10V		85	170	ns		
		V <sub>DD</sub> = 15V		70	140	ns		
t <sub>PHL</sub> or t <sub>PLH</sub>	Propagation Delay Time to Carry Output	V <sub>DD</sub> = 5V		320	640	ns		
		V <sub>DD</sub> = 10V		135	270	ns		
		V <sub>DD</sub> = 15V		110	220	ns		
t <sub>PHL</sub> or t <sub>PLH</sub>	Propagation Delay Time to Carry Output	C <sub>L</sub> = 15 pF						
		V <sub>DD</sub> = 5V		285	570	ns		
		V <sub>DD</sub> = 10V		120	240	ns		
t <sub>PHL</sub> or t <sub>PLH</sub>	Propagation Delay Time to Carry Output	V <sub>DD</sub> = 15V		95	190	ns		
		V <sub>DD</sub> = 5V		100	200	ns		
		V <sub>DD</sub> = 10V		50	100	ns		
t <sub>THL</sub> or t <sub>TLH</sub>	Transition Time/Q or Carry Output	V <sub>DD</sub> = 15V		40	80	ns		
		V <sub>DD</sub> = 5V		160	320	ns		
		V <sub>DD</sub> = 10V		70	135	ns		
t <sub>WH</sub> or t <sub>WL</sub>	Minimum Clock Pulse Width	V <sub>DD</sub> = 15V		55	110	ns		
		V <sub>DD</sub> = 5V		15		μs		
		V <sub>DD</sub> = 10V		10		μs		
t <sub>rCL</sub> or t <sub>fCL</sub>	Maximum Clock Rise and Fall Time	V <sub>DD</sub> = 15V		5		μs		
		V <sub>DD</sub> = 5V		180	360	ns		
		V <sub>DD</sub> = 10V		70	140	ns		
t <sub>SU</sub>	Minimum Set-Up Time	V <sub>DD</sub> = 15V		55	110	ns		
		V <sub>DD</sub> = 5V		1.5	3.1	MHz		
		V <sub>DD</sub> = 10V		3.7	7.4	MHz		
f <sub>CL</sub>	Maximum Clock Frequency	V <sub>DD</sub> = 15V		4.5	9	MHz		
		C <sub>IN</sub>	Average Input Capacitance	Any Input		5	7.5	pF
		C <sub>PD</sub>	Power Dissipation Capacitance	Per Package (Note 4)		65		pF

**Note 1:** "Absolute Maximum Ratings" are those values beyond which the safety of the device cannot be guaranteed. Except for "Operating Temperature Range" they are not meant to imply that the devices should be operated at these limits. The table of "Electrical Characteristics" provides conditions for actual device operation.

**Note 2:** V<sub>SS</sub> = 0V unless otherwise specified.

**Note 3:** I<sub>OH</sub> and I<sub>OL</sub> are tested one output at a time.

## AC Electrical Characteristics\*

$T_A = 25^\circ\text{C}$ ,  $C_L = 50\text{ pF}$ ,  $R_L = 200\text{ k}$ , Input  $t_{rCL} = t_{fCL} = 20\text{ ns}$ , unless otherwise specified (Continued)

Symbol	Parameter	Conditions	Min	Typ	Max	Units
<b>PRESET ENABLE OPERATION</b>						
$t_{PHL}$ or $t_{PLH}$	Propagation Delay Time to Q output	$V_{DD} = 5\text{V}$		285	570	ns
		$V_{DD} = 10\text{V}$		115	230	ns
		$V_{DD} = 15\text{V}$		95	195	ns
$t_{PHL}$ or $t_{PLH}$	Propagation Delay Time to Carry Output	$V_{DD} = 5\text{V}$		400	800	ns
		$V_{DD} = 10\text{V}$		165	330	ns
		$V_{DD} = 15\text{V}$		135	260	ns
$t_{WH}$	Minimum Preset Enable Pulse Width	$V_{DD} = 5\text{V}$		80	160	ns
		$V_{DD} = 10\text{V}$		30	60	ns
		$V_{DD} = 15\text{V}$		25	50	ns
$t_{REM}$	Minimum Preset Enable Removal Time	$V_{DD} = 5\text{V}$		150	300	ns
		$V_{DD} = 10\text{V}$		60	120	ns
		$V_{DD} = 15\text{V}$		50	100	ns
<b>CARRY INPUT OPERATION</b>						
$t_{PHL}$ or $t_{PLH}$	Propagation Delay Time to Carry Output	$V_{DD} = 5\text{V}$		265	530	ns
		$V_{DD} = 10\text{V}$		110	220	ns
		$V_{DD} = 15\text{V}$		90	180	ns
$t_{PHL}$ , $t_{PLH}$	Propagation Delay Time to Carry Output	$C_L = 15\text{ pF}$				
		$V_{DD} = 5\text{V}$		200	400	ns
		$V_{DD} = 10\text{V}$		85	170	ns
		$V_{DD} = 15\text{V}$		70	140	ns

\*AC Parameters are guaranteed by DC correlated testing.

**Note 1:** "Absolute Maximum Ratings" are those values beyond which the safety of the device cannot be guaranteed. Except for "Operating Temperature Range" they are not meant to imply that the devices should be operated at these limits. The table of "Electrical Characteristics" provides conditions for actual device operation.

**Note 2:**  $V_{SS} = 0\text{V}$  unless otherwise specified.

**Note 3:**  $I_{OH}$  and  $I_{OL}$  are tested one output at a time.

**Note 4:**  $C_{pD}$  determines the no load AC power consumption of any CMOS device. For complete explanation, see 54C/74C Family Characteristics application note, AN-90.

## Connection Diagram

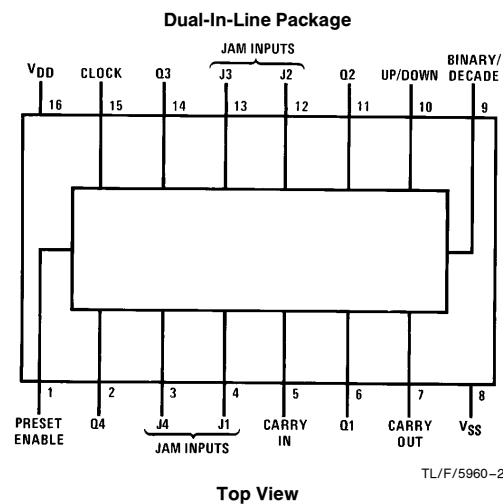

Order Number CD4029B

# Logic Waveforms

## Decade Mode

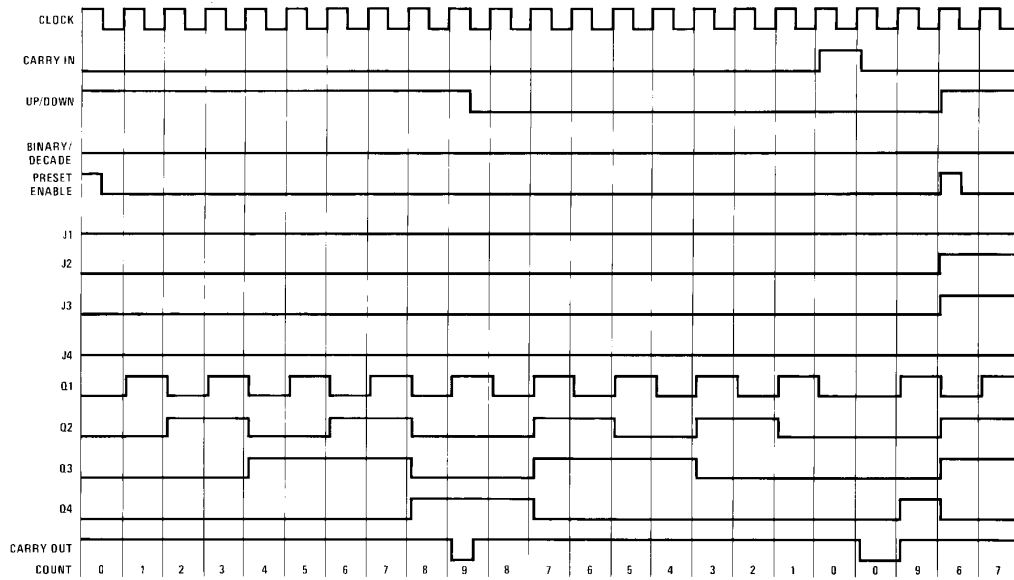

TL/F/5960-3

## Binary Mode

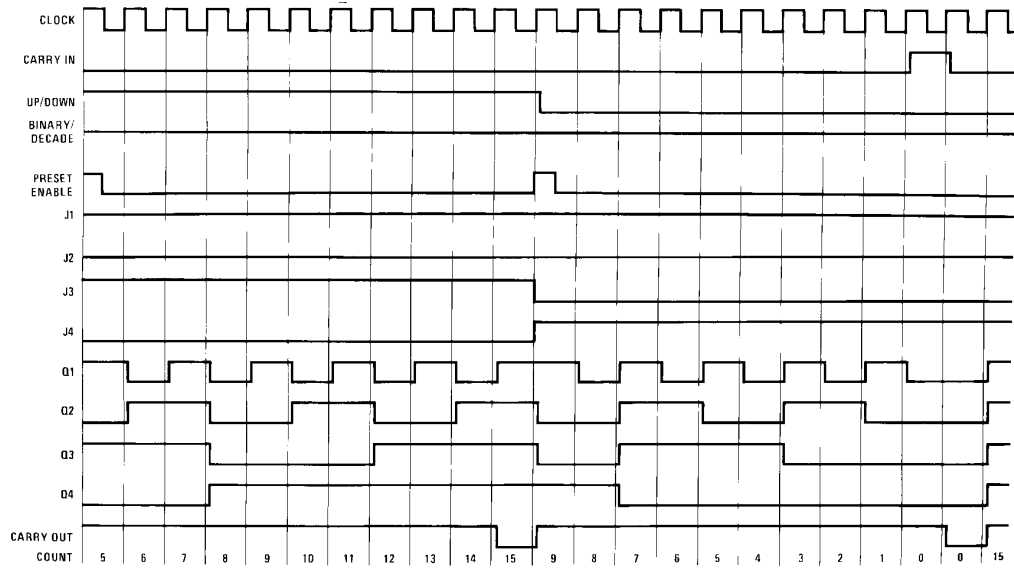

TL/F/5960-4

## Switching Time Waveforms

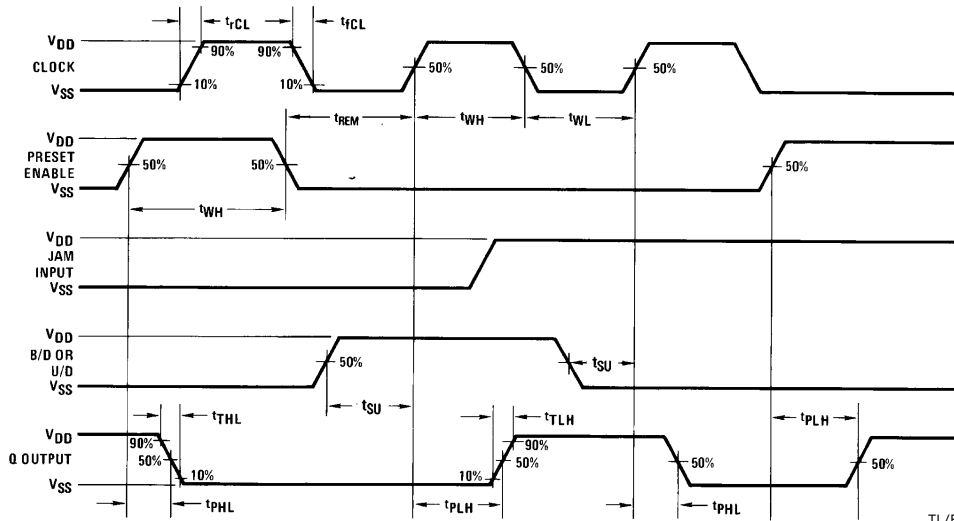

TL/F/5960-5

## Cascading Packages

### Parallel Clocking

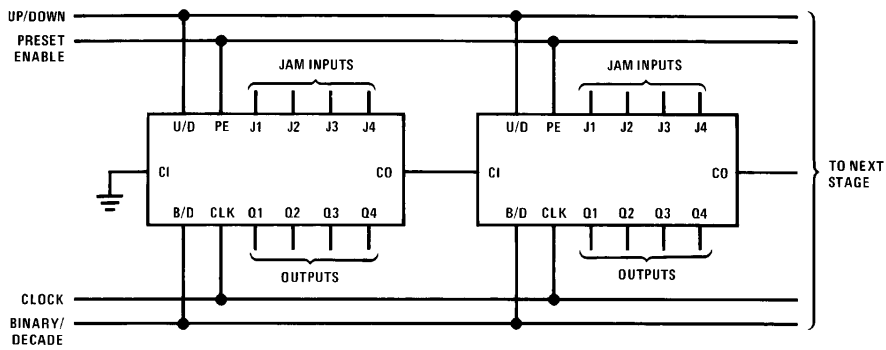

TL/F/5960-6

### Ripple Clocking

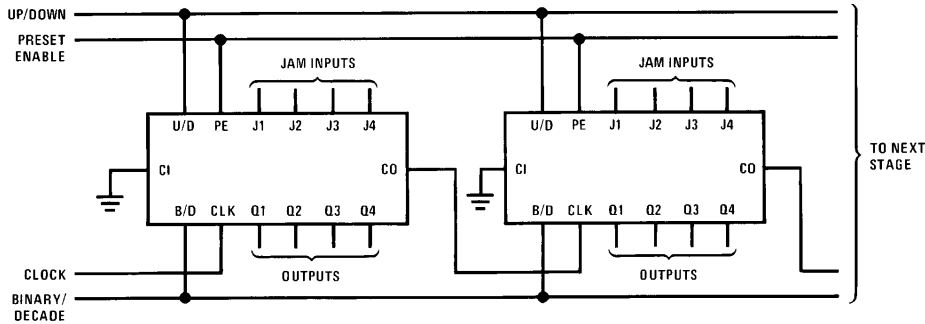

TL/F/5960-7

Carry out lines at the 2nd or later stages may have a negative-going spike due to differential internal delays. These spikes do not affect counter operation, but if the carry out is used to trigger external circuitry the carry out should be gated with the clock.



**Physical Dimensions** inches (millimeters)

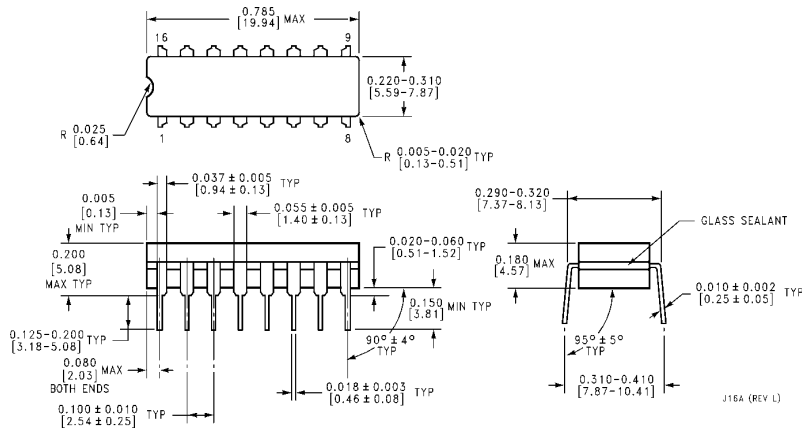

**Order Number CD4029BMJ or CD4029BCJ**  
**NS Package Number J16A**

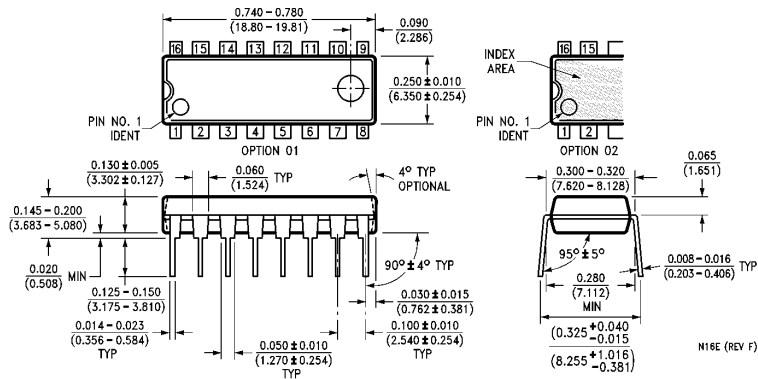

**Order Number CD4029BMN or CD4029BCN**  
**NS Package Number N16E**

**LIFE SUPPORT POLICY**

NATIONAL'S PRODUCTS ARE NOT AUTHORIZED FOR USE AS CRITICAL COMPONENTS IN LIFE SUPPORT DEVICES OR SYSTEMS WITHOUT THE EXPRESS WRITTEN APPROVAL OF THE PRESIDENT OF NATIONAL SEMICONDUCTOR CORPORATION. As used herein:

1. Life support devices or systems are devices or systems which, (a) are intended for surgical implant into the body, or (b) support or sustain life, and whose failure to perform, when properly used in accordance with instructions for use provided in the labeling, can be reasonably expected to result in a significant injury to the user.
2. A critical component is any component of a life support device or system whose failure to perform can be reasonably expected to cause the failure of the life support device or system, or to affect its safety or effectiveness.



**National Semiconductor Corporation**  
1111 West Bardin Road  
Arlington, TX 76017  
Tel: 1(800) 272-9959  
Fax: 1(800) 737-7018

**National Semiconductor Europe**  
Fax: (+49) 0-180-530 85 86  
Email: cnjwge@tevm2.nsc.com  
Deutsch Tel: (+49) 0-180-530 85 85  
English Tel: (+49) 0-180-532 78 32  
Français Tel: (+49) 0-180-532 93 58  
Italiano Tel: (+49) 0-180-534 16 80

**National Semiconductor Hong Kong Ltd.**  
19th Floor, Straight Block,  
Ocean Centre, 5 Canton Rd.  
Tsimshatsui, Kowloon  
Hong Kong  
Tel: (852) 2737-1600  
Fax: (852) 2736-9960

**National Semiconductor Japan Ltd.**  
Tel: 81-043-299-2309  
Fax: 81-043-299-2408

National does not assume any responsibility for use of any circuitry described, no circuit patent licenses are implied and National reserves the right at any time without notice to change said circuitry and specifications.

This datasheet has been downloaded from:

[www.DatasheetCatalog.com](http://www.DatasheetCatalog.com)

Datasheets for electronic components.

# Texas Instruments

<http://www.ti.com>

This file is the datasheet for the following electronic components:

CD4029 - <http://www.ti.com/product/cd4029?HQS=TI-null-null-dscatalog-df-pf-null-ww>



LittleDiode supplies new, hard to find or obsolete electronic components and semiconductors all over the world.

With over two million different components listed you are sure to find the part you need.

Feel free to visit us today at our online store:

[LittleDiode.com](http://LittleDiode.com)

Looking forward to providing you with the best possible service.