



DM54193 Synchronous Up/Down 4-Bit Binary Counter with Dual Clock

General Description

This circuit is a synchronous up/down 4-bit binary counter. Synchronous operation is provided by having all flip-flops clocked simultaneously, so that the outputs change together when so instructed by the steering logic. This mode of operation eliminates the output counting spikes normally associated with asynchronous (ripple-clock) counters.

The outputs of the four master-slave flip-flops are triggered by a low-to-high level transition of either count (clock) input. The direction of counting is determined by which count input is pulsed, while the other count input is held high.

This counter is fully programmable; that is, each output may be preset to either level by entering the desired data at the inputs while the load input is low. The output will change independently of the count pulses. This feature allows the counter to be used as modulo-N divider by simply modifying the count length with the preset inputs.

A clear input has been provided which, when taken to a high level, forces all outputs to the low level; independent of the count and load inputs. The clear, count, and load inputs are buffered to lower the drive requirements of clock drivers, etc., required for long words.

This counter was designed to be cascaded without the need for external circuitry. Both borrow and carry outputs are available to cascade both the up and down counting functions. The borrow output produces a pulse equal in width to the count down input when the counter underflows. Similarly, the carry output produces a pulse equal in width to the count up input when an overflow condition exists. The counter can then be easily cascaded by feeding the borrow and carry outputs to the count down and count up inputs respectively of the succeeding counter.

Features

- Fully independent clear input
- Synchronous operation
- Cascading circuitry provided internally
- Individual preset each flip-flop

Connection Diagram

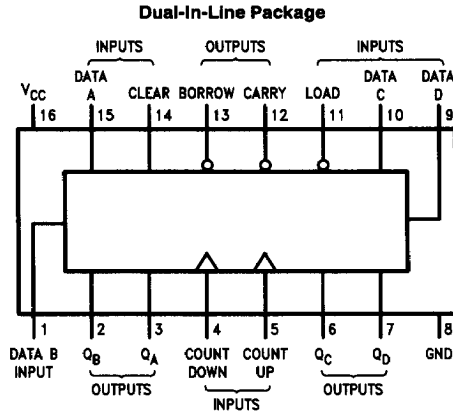

TL/F/6563-1

Absolute Maximum Ratings (Note)

If Military/Aerospace specified devices are required, please contact the National Semiconductor Sales Office/Distributors for availability and specifications.

Supply Voltage	7V
Input Voltage	5.5V
Operating Free Air Temperature Range	-55°C to +125°C
Storage Temperature Range	-65°C to +150°C

Note: The "Absolute Maximum Ratings" are those values beyond which the safety of the device cannot be guaranteed. The device should not be operated at these limits. The parametric values defined in the "Electrical Characteristics" table are not guaranteed at the absolute maximum ratings. The "Recommended Operating Conditions" table will define the conditions for actual device operation.

Recommended Operating Conditions

Symbol	Parameter	Min	Nom	Max	Units
V _{CC}	Supply Voltage	4.5	5	5.5	V
V _{IH}	High Level Input Voltage	2			V
V _{IL}	Low Level Input Voltage			0.8	V
I _{OH}	High Level Output Current			-0.4	mA
I _{OL}	Low Level Output Current			16	mA
f _{CLK}	Clock Frequency (Note 4)	0	25	20	MHz
t _w	Pulse Width (Note 4)	Clock Low	30		ns
		Clock, Clear High Load Low	20		
t _{SU}	Data Setup Time (Note 4)	20			ns
t _H	Hold Time (Note 4)	0			ns
T _A	Free Air Operating Temperature	-55		125	°C

Electrical Characteristics over recommended operating free air temperature range (unless otherwise noted)

Symbol	Parameter	Conditions	Min	Typ (Note 1)	Max	Units
V _I	Input Clamp Voltage	V _{CC} = Min, I _I = -12 mA			-1.5	V
V _{OH}	High Level Output Voltage	V _{CC} = Min, I _{OH} = Max V _{IL} = Max, V _{IH} = Min	2.4			V
V _{OL}	Low Level Output Voltage	V _{CC} = Min, I _{OL} = Max V _{IH} = Min, V _{IL} = Max			0.4	V
I _I	Input Current @ Max Input Voltage	V _{CC} = Max, V _I = 5.5V			1	mA
I _{IH}	High Level Input Current	V _{CC} = Max, V _I = 2.4V			40	μA
I _{IL}	Low Level Input Current	V _{CC} = Max, V _I = 0.4V			-1.6	mA
I _{OS}	Short Circuit Output Current	V _{CC} = Max (Note 2)	-20		-55	mA
I _{CC}	Supply Current	V _{CC} = Max (Note 3)		65	89	mA

Note 1: All typicals are at V_{CC} = 5V, T_A = 25°C.

Note 2: Not more than one output should be shorted at a time.

Note 3: I_{CC} is measured with all outputs open, CLEAR and LOAD inputs grounded, and all other inputs at 4.5V.

Note 4: T_A = 25°C and V_{CC} = 5V.

Switching Characteristics at $V_{CC} = 5V$ and $T_A = 25^\circ C$ (See Section 1 for Test Waveforms and Output Load)

Symbol	Parameter	From (Input) To (Output)	$R_L = 400\Omega, C_L = 15\text{ pF}$		Units
			Min	Max	
f_{MAX}	Maximum Clock Frequency		20		MHz
t_{PLH}	Propagation Delay Time Low to High Level Output	Count Up to Carry		26	ns
t_{PHL}	Propagation Delay Time High to Low Level Output	Count Up to Carry		24	ns
t_{PLH}	Propagation Delay Time Low to High Level Output	Count Down to Borrow		24	ns
t_{PHL}	Propagation Delay Time High to Low Level Output	Count Down to Borrow		24	ns
t_{PLH}	Propagation Delay Time Low to High Level Output	Either Count to Q		38	ns
t_{PHL}	Propagation Delay Time High to Low Level Output	Either Count to Q		47	ns
t_{PLH}	Propagation Delay Time Low to High Level Output	Load to Q		40	ns
t_{PHL}	Propagation Delay Time High to Low Level Output	Load to Q		40	ns
t_{PHL}	Propagation Delay Time High to Low Level Output	Clear to Q		35	ns

Logic Diagrams

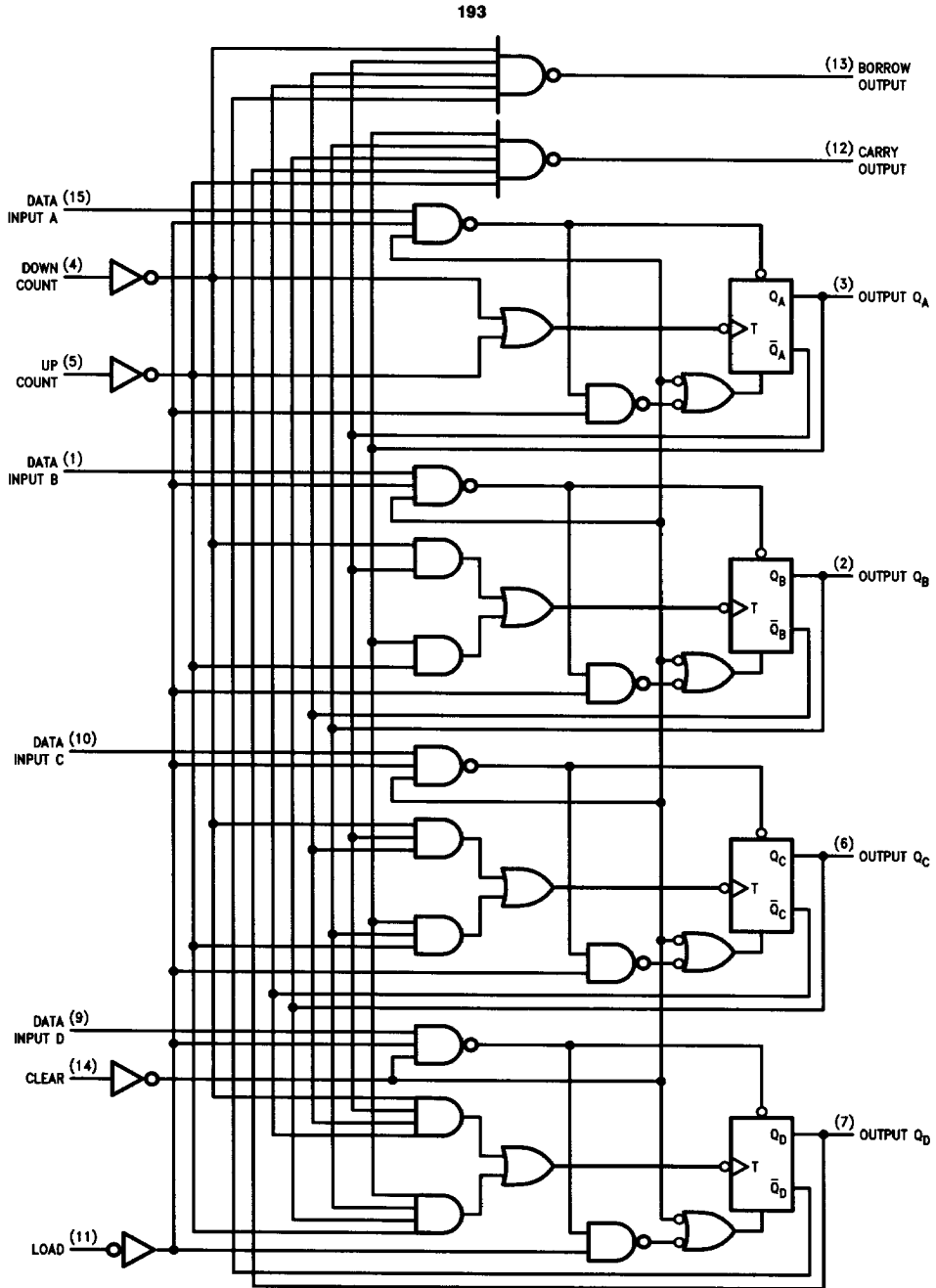

TL/F/6563-2

Timing Diagram

193 Binary Counter Typical Clear, Load, and Count Sequences

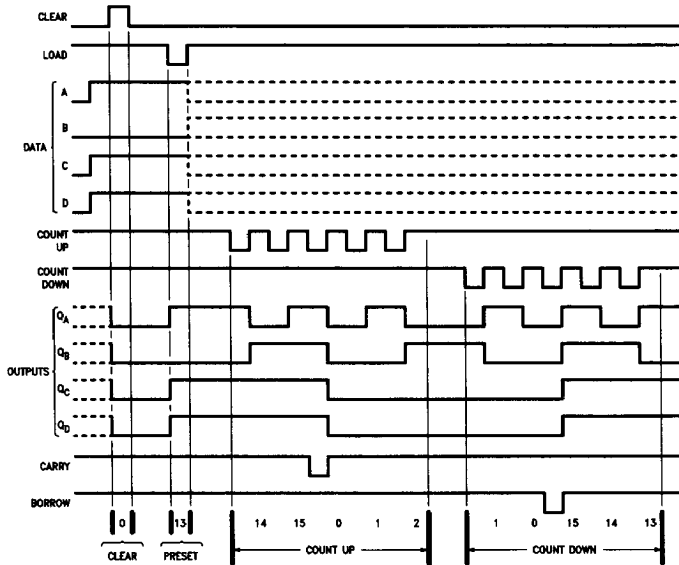

TL/F/6563-3

Note A: Clear overrides load, data, and count inputs.

Note B: When counting up, count-down input must be high, when counting down, count-up input must be high.

This datasheet has been downloaded from:

www.DatasheetCatalog.com

Datasheets for electronic components.

National Semiconductor was acquired by Texas Instruments.

http://www.ti.com/corp/docs/investor_relations/pr_09_23_2011_national_semiconductor.html

This file is the datasheet for the following electronic components:

DM54193W - <http://www.ti.com/product/dm54193w?HQS=TI-null-null-dscatalog-df-pf-null-ww>

DM54193J - <http://www.ti.com/product/dm54193j?HQS=TI-null-null-dscatalog-df-pf-null-ww>



LittleDiode supplies new, hard to find or obsolete electronic components and semiconductors all over the world.

With over two million different components listed you are sure to find the part you need.

Feel free to visit us today at our online store:

LittleDiode.com

Looking forward to providing you with the best possible service.