

HD74LS669 • Synchronous Up/Down 4-bit Binary Counters

This synchronous presettable 4-bit binary counter features an internal carry look-ahead for cascading in high-speed counting applications. Synchronous operation is provided by having all flip-flops clocked simultaneously so that the outputs change coincident with each other when so instructed by the count-enable inputs and internal gating. This mode of operation helps eliminate the output counting spikes that are normally associated with asynchronous (ripple-clock) counters. A buffered clock input triggers the four master-slave flip-flops on the rising (positive-going) edge of the clock waveform. This counter is fully programmable; that is, the outputs may each be preset to either level. The load input circuitry allows loading with the carry-enable output of cascaded counters. As loading is synchronous, setting up a low level at the load input disables the counter and causes the outputs to agree with the data inputs after the next clock pulse. The carry look-ahead circuitry provides for cascading counters for n -bit synchronous applications without additional gating. Instrumental in accomplishing this function are two count enable inputs and a carry output. Both count enable inputs (\bar{P} and \bar{T})

must be low to count. The direction of the count is determined by the level of the up/down input. When the input is high, the counter counts up; when low, it counts down. Input \bar{T} is fed forward to enable the carry output. The carry output thus enabled will produce a low-level output pulse with a duration approximately equal to the high portion of the Q_A output when counting up and approximately equal to the low portion of the Q_A output when counting down. This low level overflow carry pulse can be used to enable successive cascaded stages.

Transitions at the enable \bar{P} or \bar{T} inputs are allowed regardless of the level of the clock input. All inputs are diode-clamped to minimize transmission-line effects, thereby simplifying system design. This counter features a fully independent clock circuit. Changes at control inputs (enable \bar{P} , enable \bar{T} , load, up/down) that will modify the operating mode have no effect until clocking occurs. The function of the counter (whether enabled, disabled, loading, or counting) will be dictated solely by the conditions meeting the stable setup and hold times.

■ BLOCK DIAGRAM

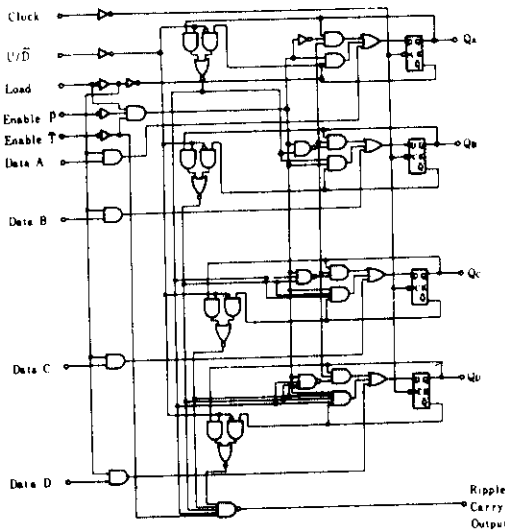

■ PIN ARRANGEMENT

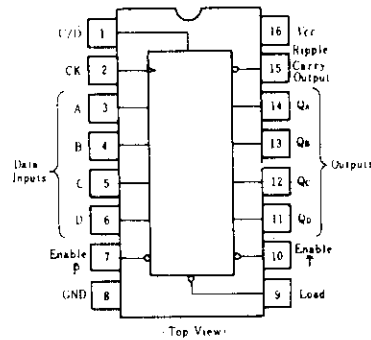

■ RECOMMENDED OPERATING CONDITIONS

Item	Symbol	min	typ	max	Unit
Output current	I_{OH}	—	—	-400	μA
Output current	I_{OL}	—	—	8	mA
Clock frequency	f_{clock}	0	—	25	MHz
Clock pulse width	$t_{w(CK)}$	25	—	—	ns
Setup time	Input Data A, B, C, D	25	—	—	ns
	Enable \bar{P} , \bar{T}	35	—	—	
	Load	30	—	—	
	Up/Down	35	—	—	
Hold time	t_h	0	—	—	ns

■ ELECTRICAL CHARACTERISTICS ($T_a = -20 \sim +75^\circ\text{C}$)

Item		Symbol	Test Conditions	min	typ*	max	Unit	
Input voltage		V_{IH}		2	—	—	V	
		V_{IL}		—	—	0.8	V	
Output voltage		V_{OH}	$V_{CC}=4.75\text{V}, V_{IH}=2\text{V}, V_{IL}=0.8\text{V}, I_{OH}=-400\mu\text{A}$	2.7	—	—	V	
		V_{OL}	$V_{CC}=4.75\text{V}, V_{IH}=2\text{V}, V_{IL}=0.8\text{V}$	$I_{OL}=4\text{mA}$	—	—	0.4	V
				$I_{OL}=8\text{mA}$	—	—	0.5	V
Input current	A, B, C, D, \bar{P} , U/ \bar{D}	I_{IH}	$V_{CC}=5.25\text{V}, V_I=2.7\text{V}$	—	—	20	μA	
	Clock, \bar{T}			—	—	20		
	Load			—	—	40		
	A, B, C, D, \bar{P} , U/ \bar{D}	I_{IL}	$V_{CC}=5.25\text{V}, V_I=0.4\text{V}$	—	—	-0.4	mA	
	Clock, \bar{T}			—	—	-0.4		
	Load			—	—	-0.8		
	A, B, C, D, \bar{P} , U/ \bar{D}	I_I	$V_{CC}=5.25\text{V}, V_I=7\text{V}$	—	—	0.1	mA	
	Clock, \bar{T}			—	—	0.1		
	Load			—	—	0.2		
Short-circuit output current		I_{OS}	$V_{CC}=5.25\text{V}$	-20	—	-100	mA	
Supply current **		I_{CC}	$V_{CC}=5.25\text{V}$	—	20	34	mA	
Input clamp voltage		V_{IK}	$V_{CC}=4.75\text{V}, I_{IH}=-18\text{mA}$	—	—	-1.5	V	

* $V_{CC}=5\text{V}, T_a=25^\circ\text{C}$

** I_{CC} is measured after applying a momentary 4.5V, then ground, to clock input with all other inputs grounded the outputs open.

■ SWITCHING CHARACTERISTICS ($V_{CC}=5\text{V}, T_a=25^\circ\text{C}$)

Item	Symbol	Inputs	Outputs	Test Conditions	min	typ	max	Unit
Maximum count frequency	f_{MAX}				25	32	—	MHz
Propagation delay time	t_{PLH}	Clock	Ripple	$C_L=15\text{pF}, R_L=2\text{k}\Omega$	—	26	40	ns
	t_{PHL}		Carry		—	40	60	
	t_{PLH}	Clock	$Q_A \sim Q_D$		—	18	27	ns
	t_{PHL}				—	18	27	
	t_{PLH}	Enable \bar{T}	Ripple		—	11	17	ns
	t_{PHL}		Carry		—	29	45	
	t_{PLH}	Up/Down	Ripple		—	22	35	ns
	t_{PHL}		Carry		—	26	40	

HD74LS669

TESTING METHOD

1) Test Circuit

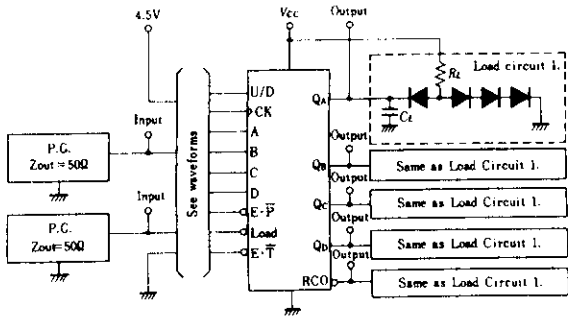

- Notes) 1. C_L includes probe and jig capacitance.
2. All diodes are 1S2074 (H).

Waveform

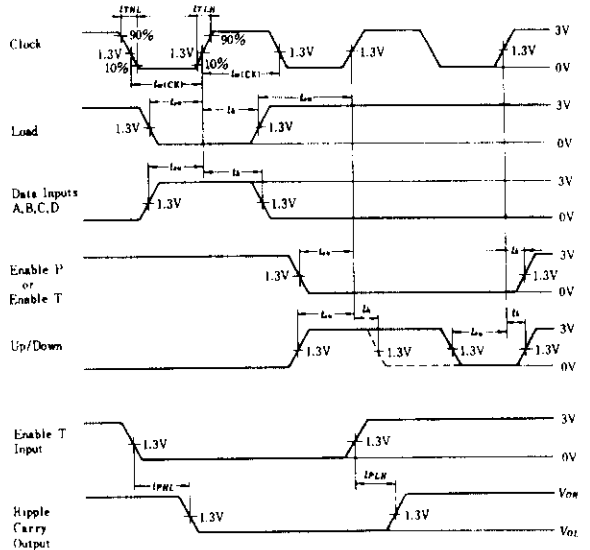

COUNT SEQUENCE

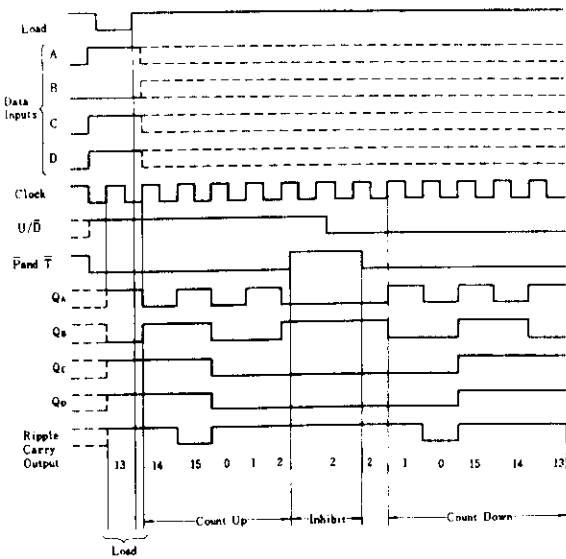

- Notes) 1. t_{PLH} and t_{PHL} from enable \bar{T} input to ripple carry output assume that the counter is at the maximum count (Q_A through Q_D high).
2. Propagation delay time from up/down to ripple carry must be measured with the counter at either a minimum or a maximum count. As the logic level of the up/down input is changed, the ripple carry output will follow. If the count is minimum (0) the ripple carry output transition will be in phase. If the count is maximum (15) the ripple carry output will be out of phase.
3. Input pulse: $t_{TLH} \leq 15\text{ns}$, $t_{THL} \leq 6\text{ns}$, $PRR = 1\text{MHz}$

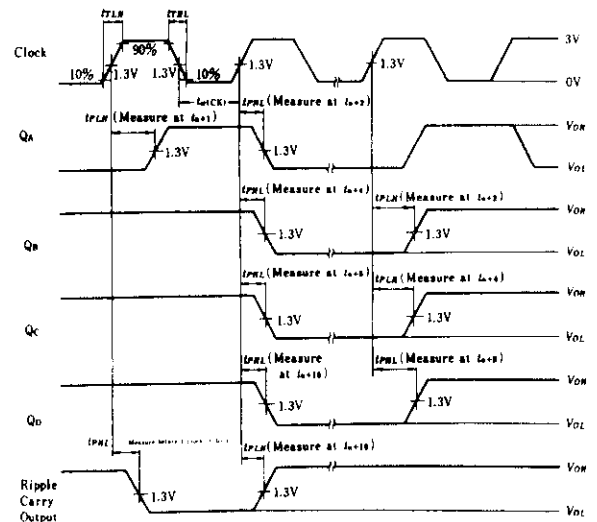

- Notes) 1. Input pulse: $t_{TLH} \leq 15\text{ns}$, $t_{THL} \leq 6\text{ns}$, $PRR = 1\text{MHz}$, duty cycle 50%.
2. For f_{max} , $t_{TLH} + t_{THL} \leq 2.5\text{ns}$.
3. t_n is the bit-time when all outputs are low.

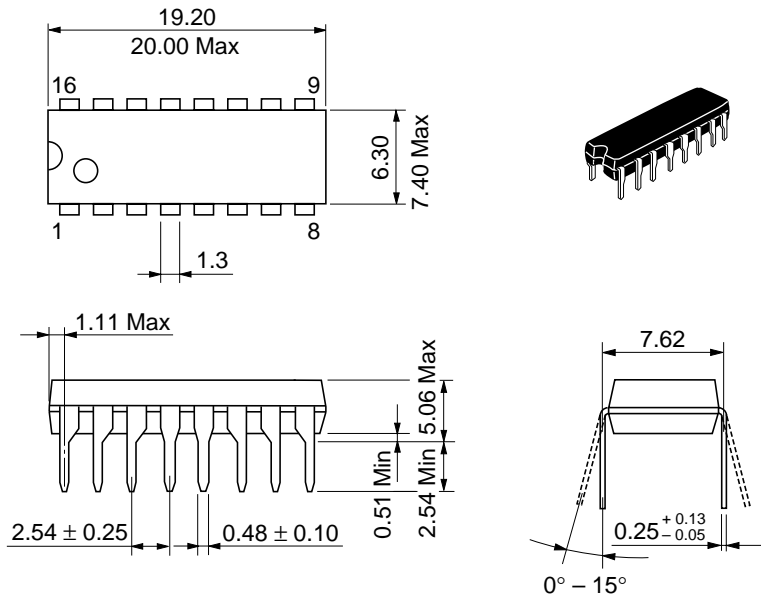

Hitachi Code	DP-16
JEDEC	Conforms
EIAJ	Conforms
Weight (reference value)	1.07 g

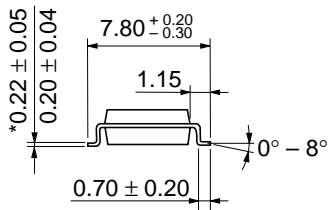

*Dimension including the plating thickness
Base material dimension

Hitachi Code	FP-16DA
JEDEC	—
EIAJ	Conforms
Weight (reference value)	0.24 g



*Dimension including the plating thickness
 Base material dimension

Hitachi Code	FP-16DN
JEDEC	Conforms
EIAJ	Conforms
Weight (reference value)	0.15 g

Cautions

1. Hitachi neither warrants nor grants licenses of any rights of Hitachi's or any third party's patent, copyright, trademark, or other intellectual property rights for information contained in this document. Hitachi bears no responsibility for problems that may arise with third party's rights, including intellectual property rights, in connection with use of the information contained in this document.
2. Products and product specifications may be subject to change without notice. Confirm that you have received the latest product standards or specifications before final design, purchase or use.
3. Hitachi makes every attempt to ensure that its products are of high quality and reliability. However, contact Hitachi's sales office before using the product in an application that demands especially high quality and reliability or where its failure or malfunction may directly threaten human life or cause risk of bodily injury, such as aerospace, aeronautics, nuclear power, combustion control, transportation, traffic, safety equipment or medical equipment for life support.
4. Design your application so that the product is used within the ranges guaranteed by Hitachi particularly for maximum rating, operating supply voltage range, heat radiation characteristics, installation conditions and other characteristics. Hitachi bears no responsibility for failure or damage when used beyond the guaranteed ranges. Even within the guaranteed ranges, consider normally foreseeable failure rates or failure modes in semiconductor devices and employ systemic measures such as fail-safes, so that the equipment incorporating Hitachi product does not cause bodily injury, fire or other consequential damage due to operation of the Hitachi product.
5. This product is not designed to be radiation resistant.
6. No one is permitted to reproduce or duplicate, in any form, the whole or part of this document without written approval from Hitachi.
7. Contact Hitachi's sales office for any questions regarding this document or Hitachi semiconductor products.

HITACHI

Hitachi, Ltd.

Semiconductor & Integrated Circuits.
Nippon Bldg., 2-6-2, Ohte-machi, Chiyoda-ku, Tokyo 100-0004, Japan
Tel: Tokyo (03) 3270-2111 Fax: (03) 3270-5109

URL North America : <http://semiconductor.hitachi.com/>
 Europe : <http://www.hitachi-eu.com/hel/ecg>
 Asia (Singapore) : <http://www.has.hitachi.com.sg/grp3/sicd/index.htm>
 Asia (Taiwan) : http://www.hitachi.com.tw/E/Product/SICD_Frame.htm
 Asia (HongKong) : <http://www.hitachi.com.hk/eng/bo/grp3/index.htm>
 Japan : <http://www.hitachi.co.jp/Sicd/indx.htm>

For further information write to:

Hitachi Semiconductor
(America) Inc.
179 East Tasman Drive,
San Jose, CA 95134
Tel: <1> (408) 433-1990
Fax: <1> (408) 433-0223

Hitachi Europe GmbH
Electronic components Group
Dornacher Straße 3
D-85622 Feldkirchen, Munich
Germany
Tel: <49> (89) 9 9180-0
Fax: <49> (89) 9 29 30 00

Hitachi Europe Ltd.
Electronic Components Group.
Whitebrook Park
Lower Cookham Road
Maidenhead
Berkshire SL6 8YA, United Kingdom
Tel: <44> (1628) 585000
Fax: <44> (1628) 778322

Hitachi Asia Pte. Ltd.
16 Collyer Quay #20-00
Hitachi Tower
Singapore 049318
Tel: 535-2100
Fax: 535-1533

Hitachi Asia Ltd.
Taipei Branch Office
3F, Hung Kuo Building, No.167,
Tun-Hwa North Road, Taipei (105)
Tel: <886> (2) 2718-3666
Fax: <886> (2) 2718-8180

Hitachi Asia (Hong Kong) Ltd.
Group III (Electronic Components)
7/F., North Tower, World Finance Centre,
Harbour City, Canton Road, Tsim Sha Tsui,
Kowloon, Hong Kong
Tel: <852> (2) 735 9218
Fax: <852> (2) 730 0281
Telex: 40815 HITEC HX

Copyright ' Hitachi, Ltd., 1999. All rights reserved. Printed in Japan.

HITACHI



LittleDiode supplies new, hard to find or obsolete electronic components and semiconductors all over the world.

With over two million different components listed you are sure to find the part you need.

Feel free to visit us today at our online store:

LittleDiode.com

Looking forward to providing you with the best possible service.