

74F525 Programmable Counter

General Description

The 'F525 is a multi-function 28-pin device. It consists of a 16-bit count-down counter, logic to control the counter, logic to control the state of the outputs and a PLA to decode the particular function selected by the user. The list of high-speed timing applications include:

Features

- Baud rate generator
- Digitally programmed monostable
- Variable system frequency generator
- Digital filter variable sampling rate
- 16-bit data path
- External trigger
- Extremely accurate one shot w/pulse widths from 50 ns to 3.27 ms @CP = 40 MHz

Commercial	Package Number	Package Description
74F525QC (Note 1)	V28A	28-Lead Molded Plastic Leaded Chip Carrier
74F525SC (Note 1)	M28B	28-Lead (0.300" Wide) Molded Small Outline, JEDEC
74F525PC	N28B	28-Lead (0.600" Wide) Molded Dual-In-Line Package

Note 1: Devices also available in 13" reel. Use suffix = SCX and QCX.

Connection Diagrams

**Pin Assignment
DIP and SOIC**

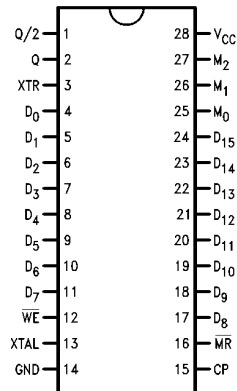

TL/F/9547-2

**Pin Assignment
for PCC**

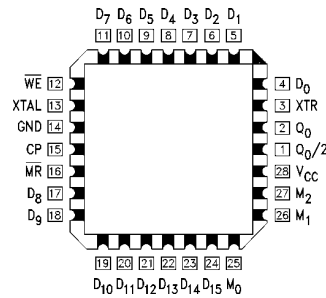

TL/F/9547-3

Logic Symbol

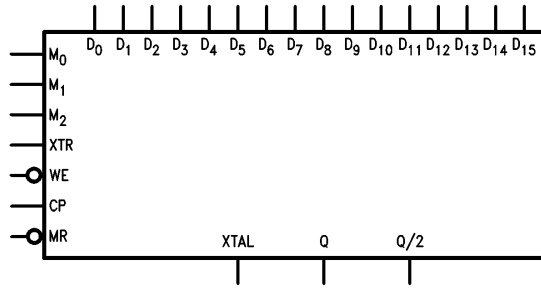

TL/F/9547-1

Unit Loading/Fan Out

Pin Names	Description	74F	
		U.L. HIGH/LOW	Input I _{IH} /I _{IL} Output I _{OH} /I _{OL}
Q	Ouput (Primarily indicates when the counter has reached zero)	50/33.3	- 1 mA/20 mA
Q/2	Output (Divides Q by 2)	50/33.3	- 1 mA/20 mA
M ₀ -M ₂	Status Inputs	1.0/1.0	20 μA/-0.6 mA
MR	Master Reset	1.0/1.0	20 μA/-0.6 mA
CP	Clock Pulse	1.0/2.0	20 μA/-1.2 mA
D ₀ -D ₁₅	Data Inputs	1.0/1.0	20 μA/-0.6 mA
WE	Write Enable Input	1.0/1.0	20 μA/-0.6 mA
XTR	External Trigger Input	1.0/2.0	20 μA/-1.2 mA
XTAL	Crystal Output	1.0/1.0	20 μA/-0.6 mA

Functional Description

The multi-function aspect of the device consists of eight different modes of operation. An explanation of the operation of the device in each of the modes follows. However, there is one operation that is independent of the selected mode: the loading of data. Data is latched into a set of data latches when \overline{WE} is brought from a LOW to a HIGH state. The latches are transparent when \overline{WE} is held LOW.

Operation Notes:

1. Device should be reset before operation.
2. The XTR input acts as a select line for the clock.
3. With XTR low, the clock goes into the counter.
4. With XTR high, the clock loads the counter.
5. In mode 4 and 5, during counting, the counter cannot be reloaded. XTR high freezes the count.
6. Mode 7 is the only auto-reload mode, all other modes require an XTR pulse to begin.
7. Loading 0 into the latches idles the device.

MODE 0: Interval Timer with Level Output

While XTR is HIGH, the data in the data latches is loaded into the counter upon the next positive edge of CP. The negative edge of XTR enables the count-down to begin with the next positive edge of CP. When the count reaches zero,

Q, normally LOW, is brought HIGH and Q/2 toggles state. Taking XTR HIGH at any time enables the data in the data latches to be loaded into the counter on the rising edge of CP and clears Q. See *Figure 1*.

MODE 1: Interval Timer with Inverted Level Output

The operation is exactly the same as in Mode 0 except that Q is normally HIGH and goes LOW when the count reaches zero. Q/2 toggles on the negative-edge of Q. See *Figure 1*.

MODE 2: Interval Timer with Pulse Output

While XTR is HIGH, the data in the data latches is loaded into the counter upon the next positive edge of CP. The negative edge of XTR enables the count-down to begin with the next positive edge of CP. When the count reaches zero, Q, normally LOW, is brought HIGH for a single period of CP. Q/2 toggles state on the positive edge of Q. Taking XTR HIGH at any time causes the data in the data latches to be loaded into the counter on the rising edge of CP and clears Q. See *Figure 2*.

MODE 3: Interval Timer with Inverted Pulse Output

The operation is exactly the same as in Mode 2 except that Q is normally HIGH and goes LOW for a single period of CP. Q/2 toggles on the negative edge of Q. See *Figure 2*.

Functional Description (Continued)

Function Table

M ₂	M ₁	M ₀	Function
0	0	0	Mode 0
0	0	1	Mode 1
0	1	0	Mode 2
0	1	1	Mode 3
1	0	0	Mode 4
1	0	1	Mode 5
1	1	0	Mode 6
1	1	1	Mode 7

MODE 4: Interval Timer, Pulse Output with Count Hold

While XTR is HIGH, the data in the data latches is loaded into the counter upon the positive edge of CP. The negative edge of XTR enables the count-down to begin with the next positive edge of CP. When the count reaches zero, Q, normally low, is brought HIGH for a single period of CP. Q/2 toggles state on the positive edge of Q. Taking XTR HIGH before the counters reach zero, stops the count-down from the point where it was held. Data cannot be reloaded into the counter until a count of zero is reached. See *Figure 3*.

MODE 5: Interval Timer, Inverted Pulse Output with Count Hold

The operation is exactly the same as Mode 4 except that Q is normally HIGH and goes LOW for a single period of CP. Q/2 toggles on the negative-edge of Q. See *Figure 3*.

MODE 6: Retriggerable Synchronous One-Shot

When XTR is HIGH, the data in the data latches is loaded into the counter upon the positive edge of CP. The negative edge of XTR enables the count-down to begin with the next positive edge of CP, where Q, normally LOW, is then brought HIGH and the counter is decremented when the count reaches zero, Q is brought LOW, and Q/2 is toggled. Bringing XTR HIGH during the count-down will allow the data in the data latches to be loaded into the counter with the next positive edge of CP, but will not affect Q. See *Figure 4*. NOTE that the pulse width of Q will be N-1 clock cycles, where N is the number loaded into the counter. N=1 should not be used as this may cause unpredictable results.

MODE 7: Frequency Generator

When XTR is HIGH, the data in the data latches is loaded into the counter upon the positive edge of CP. The negative edge of XTR enables the count-down to begin with the next positive edge of CP. When the count reaches zero, Q, normally LOW, is brought HIGH for a single period of CP and Q/2 is toggled. The same clock edge that brings Q HIGH, also loads the data in the data latches into the counter. The counter will start to count on the next positive edge of CP. This mode will run continuously after an initial XTR until stopped by MR. Taking XTR HIGH at any time causes the data in the data latches to be loaded into the counter and Q output to be cleared with the next positive edge of CP. See *Figure 5*.

Block Diagram

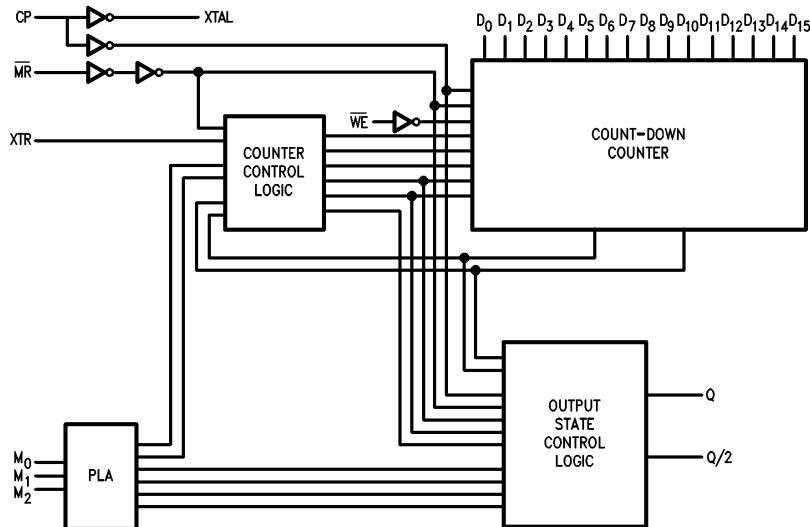

TL/F/9547-4

Timing Diagrams

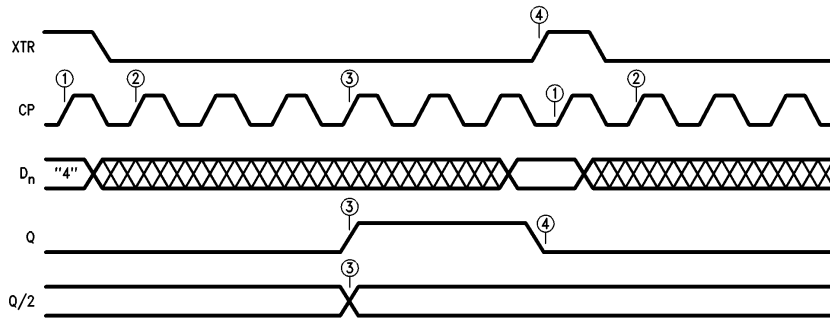

TL/F/9547-5

- ⊙ With XTR HIGH, the rising edge of CP loads data from the latches to the counter.
- ⊙ With XTR LOW, the rising edge of CP begins count-down cycle.
- ⊙ When the count reaches zero, Q goes HIGH, and Q/2 toggles state.
- ⊙ The next occurrence of XTR clears Q.

FIGURE 1. MODE 0 and MODE 1 (Inverse Output of Mode 0)
 $\overline{M}_n = 000, 001$

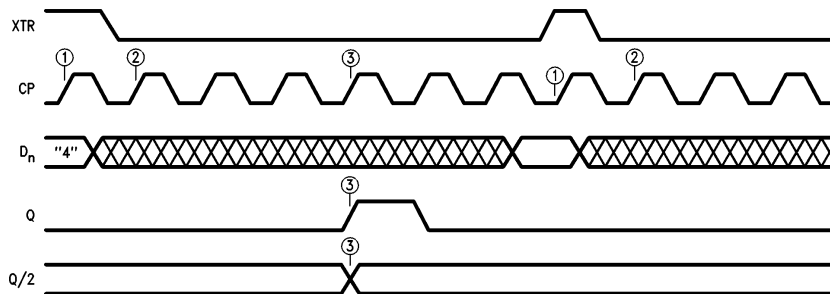

TL/F/9547-6

- ⊙ With XTR HIGH, the rising edge of CP loads data from the latches to the counter.
- ⊙ With XTR LOW, the rising edge of CP begins the count-down cycle.
- ⊙ When the count reaches zero, Q goes HIGH for one period of CP, and Q/2 toggles state.

FIGURE 2. MODE 2 and MODE 3 (Inverse Output of Mode 2)
 $\overline{M}_n = 010, 011$

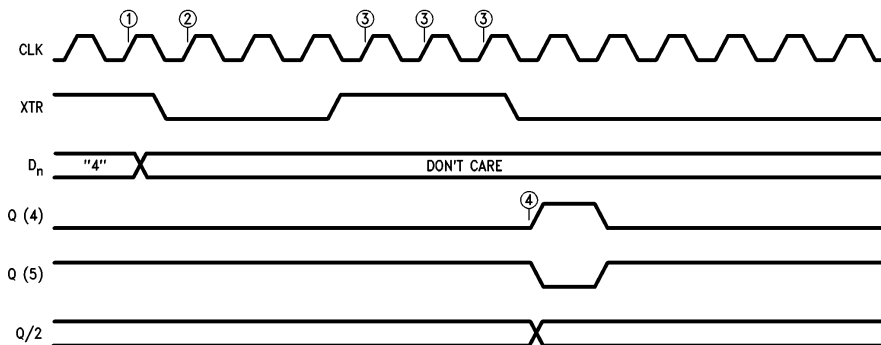

TL/F/9547-7

FIGURE 3. MODE 4 and MODE 5
 $\overline{M}_n = 100, 101$

- ⊙ With XTR HIGH, the rising edge of CP loads data from the latches into the counter.
 - ⊙ With XTR LOW, the rising edge of CP begins the count-down.
 - ⊙ With XTR HIGH, during count-down, the rising edge of CP does nothing.
 - ⊙ When the count reaches zero, Q goes HIGH for one clock cycle and Q/2 toggles state.
- Note:** Once the count reaches zero, the counter can be reloaded with XTR HIGH.

Timing Diagrams (Continued)

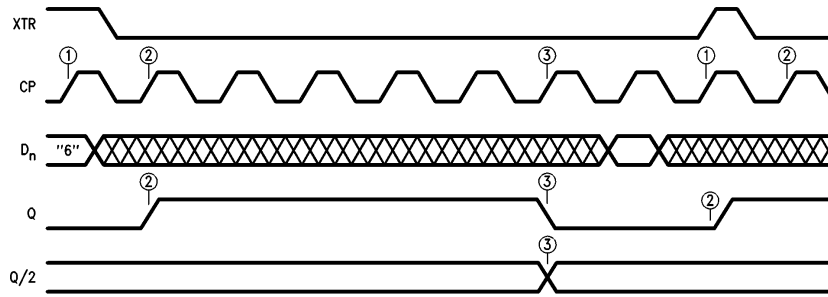

TL/F/9547-8

FIGURE 4. MODE 6
 $\bar{M}_n = 110$

⊙ With XTR HIGH, the rising edge of CP loads data from the latches to the counter.

⊙ With XTR LOW, the rising edge of CP begins the count, and Q goes HIGH.

⊙ When the count reaches zero, Q goes LOW, and Q/2 toggles state. Bringing XTR HIGH before count reaches zero will reload the counter, but not affect Q.

Notes:

Loading N=0 halts counter; loading N=1 will result in undefined operation.

$$\text{Pulse width} = (2/CP) * (N - 1)$$

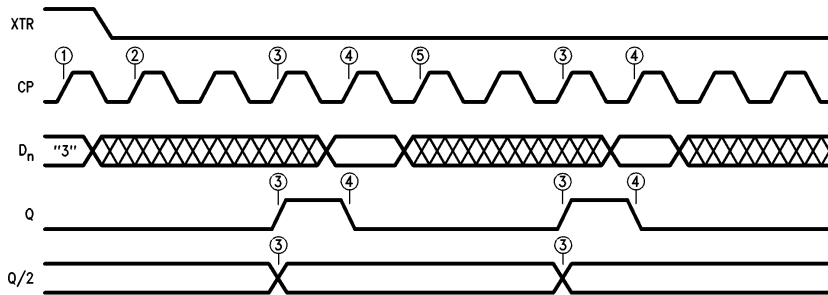

TL/F/9547-9

FIGURE 5. MODE 7
 $\bar{M}_n = 111$

⊙ With XTR HIGH, the rising edge of CP, loads data from the latches to the counter.

⊙ On the falling edge of XTR, the rising edge of CP begins count-down.

⊙ When count reaches zero, Q goes HIGH for one period of CP, and Q/2 toggles on the Q rising edge.

⊙ On the rising edge of CP on which Q goes LOW, the counters are reloaded.

⊙ Count-down begins again.

Absolute Maximum Ratings (Note 1)

Storage Temperature	-65°C to +150°C
Ambient Temperature under Bias	-55°C to +125°C
Junction Temperature under Bias	-55°C to +175°C
Plastic	-55°C to +150°C
V _{CC} Pin Potential to Ground Pin	-0.5V to +7.0V
Input Voltage (Note 2)	-0.5V to +7.0V
Input Current (Note 2)	-30 mA to +5.0 mA
Voltage Applied to Output in HIGH State (with V _{CC} = 0V)	
Standard Output	-0.5V to V _{CC}
TRI-STATE® Output	-0.5V to +5.5V
Current Applied to Output in LOW State (Max)	twice the rated I _{OL} (mA)

Note 1: Absolute maximum ratings are values beyond which the device may be damaged or have its useful life impaired. Functional operation under these conditions is not implied.

Note 2: Either voltage limit or current limit is sufficient to protect inputs.

Recommended Operating Conditions

Free Air Ambient Temperature	0°C to +70°C
Commercial	
Supply Voltage	+4.5V to +5.5V
Commercial	

DC Electrical Characteristics

Symbol	Parameter	74F			Units	V _{CC}	Conditions
		Min	Typ	Max			
V _{IH}	Input HIGH Voltage	2.0			V		Recognized as a HIGH Signal
V _{IL}	Input LOW Voltage			0.8	V		Recognized as a LOW Signal
V _{CD}	Input Clamp Diode Voltage			-1.2	V	Min	I _{IN} = -18 mA
V _{OH}	Output HIGH Voltage	74F 10% V _{CC} 74F 5% V _{CC}	2.5 2.7		V	Min	I _{OH} = -1 mA I _{OH} = -1 mA
V _{OL}	Output LOW Voltage	74F 10% V _{CC}		0.5	V	Min	I _{OL} = 20 mA
I _{IH}	Input HIGH Current	74F		5.0	μA	Max	V _{IN} = 2.7V
I _{BVI}	Input HIGH Current Breakdown Test	74F		7.0	μA	Max	V _{IN} = 7.0V
I _{CEX}	Output HIGH Leakage Current	74F		50	μA	Max	V _{OUT} = V _{CC}
V _{ID}	Input Leakage Test	74F	4.75		V	0.0	I _{ID} = 1.9 μA All Other Pins Grounded
I _{OD}	Output Leakage Circuit Current	74F		3.75	μA	0.0	V _{IOD} = 150 mV All Other Pins Grounded
I _{IL}	Input LOW Current			-0.6 -1.2	mA	Max	V _{IN} = 0.5V (D0-D15) V _{IN} = 0.5V (CP, XTR)
I _{OS}	Output Short-Circuit Current		-60	-150	mA	Max	V _{OUT} = 0V
I _{CCH}	Power Supply Current		106	160	mA	Max	V _O = HIGH
I _{CCL}	Power Supply Current		106	160	mA	Max	V _O = LOW

AC Electrical Characteristics

Symbol	Parameter	74F			74F		Units
		T _A = +25°C V _{CC} = +5.0V C _L = 50 pF			T _A , V _{CC} = Com C _L = 50 pF		
		Min	Typ	Max	Min	Max	
f _{max}	Maximum Clock Frequency	50	60		40		MHz
t _{PLH} t _{PHL}	Propagation Delay CP to Q	9.0 8.0	16.0 12.0	20.5 15.5	8.0 7.0	22.5 17.5	ns
t _{PLH} t _{PHL}	Propagation Delay CP to Q/2	9.0 10.0	15.5 15.5	20.0 20.0	8.0 9.0	22.0 22.0	ns
t _{PLH} t _{PHL}	Propagation Delay XTR to Q	8.5 6.0	12.0 10.5	15.5 13.5	7.5 5.0	17.5 15.0	ns
t _{PLH} t _{PHL}	Propagation Delay MR to Q	11.5 9.0	16.5 12.5	21.0 16.0	10.5 8.0	23.0 18.0	ns
t _{PLH} t _{PHL}	Propagation Delay MR to Q/2	8.0 7.0	14.0 10.5	17.5 13.5	7.0 6.0	19.5 15.0	ns
t _{PLH} t _{PHL}	Propagation Delay M _n to Q	10.0 10.5	15.0 17.0	19.0 21.5	9.0 9.5	21.0 23.5	ns

AC Operating Requirements

Symbol	Parameter	74F		74F		Units
		T _A = +25°C V _{CC} = +5.0V		T _A , V _{CC} = Com		
		Min	Max	Min	Max	
t _s (H) t _s (L)	Setup Time, HIGH or LOW D _n to WE	2.0 4.0		2.5 4.5		ns
t _h (H) t _h (L)	Hold Time, HIGH or LOW D _n to WE	0 2.0		0 2.5		ns
t _s (H) t _s (L)	Setup Time, HIGH or LOW D _n to CP	9.0 10.5		10.0 12.0		ns
t _h (H) t _h (L)	Hold Time, HIGH or LOW D _n to CP	0 0		0 0		ns
t _s (H) t _s (L)	Setup Time, HIGH or LOW XTR to CP	7.0 8.0		8.0 9.0		ns
t _h (H)	Hold Time, HIGH or LOW XTR to CP	0		0		ns
t _s (H) t _s (L)	Setup Time, HIGH or LOW Mode to CP	33.5 33.5		35.5 35.5		ns
t _w (H)	XTR Pulse Width, HIGH	11.5		13.0		ns
t _w (L)	MR Pulse Width, LOW	7.0		8.0		ns
t _w (L)	WE Pulse Width, LOW	4.5		5.0		ns
t _w (H) t _w (L)	CP Pulse Width HIGH or LOW	3.5 9.5		4.0 10.5		ns
t _{rec}	Recovery Time MR to CP	5.0		6.0		ns
t _{rec}	Recovery Time Mode to CP	30.0		32.0		ns

Ordering Information

The device number is used to form part of a simplified purchasing code where the package type and temperature range are defined as follows:

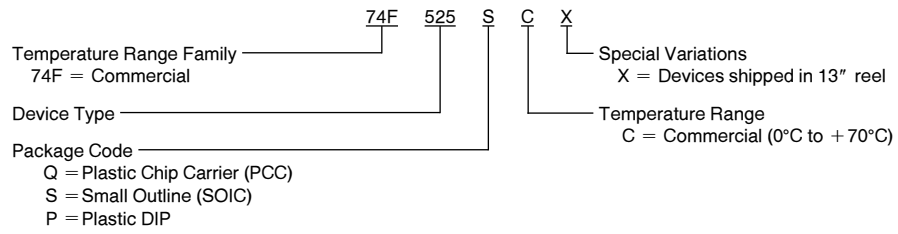

Physical Dimensions inches (millimeters)

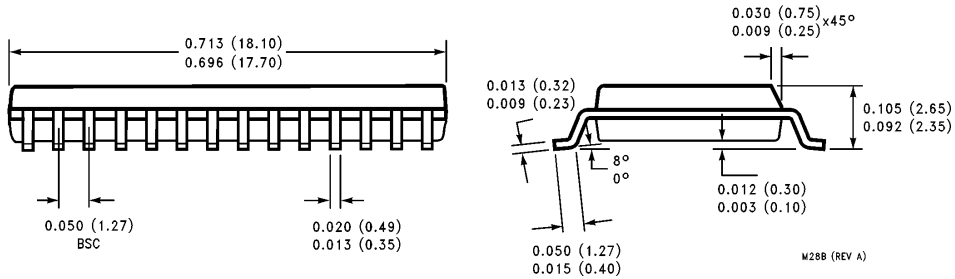
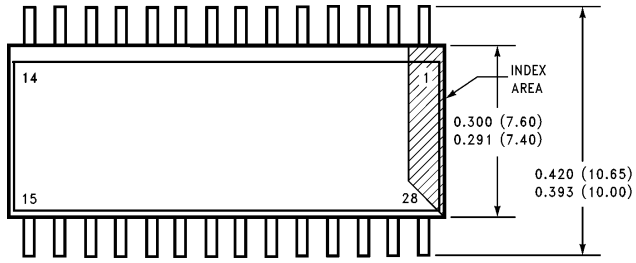

28-Lead (0.300" Wide) Molded Small Outline Package, JEDEC (S)
NS Package Number M28B

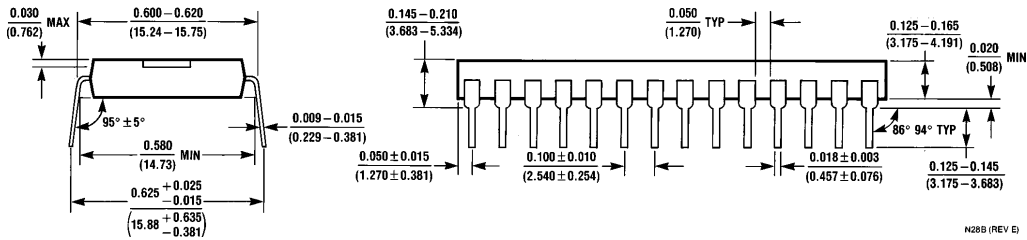
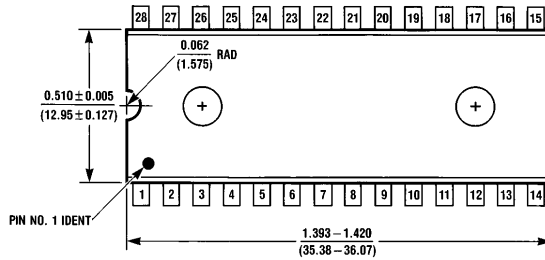

28-Lead (0.600" Wide) Molded Dual-In-Line Package, (P)
NS Package Number N28B

Physical Dimensions inches (millimeters) (Continued)

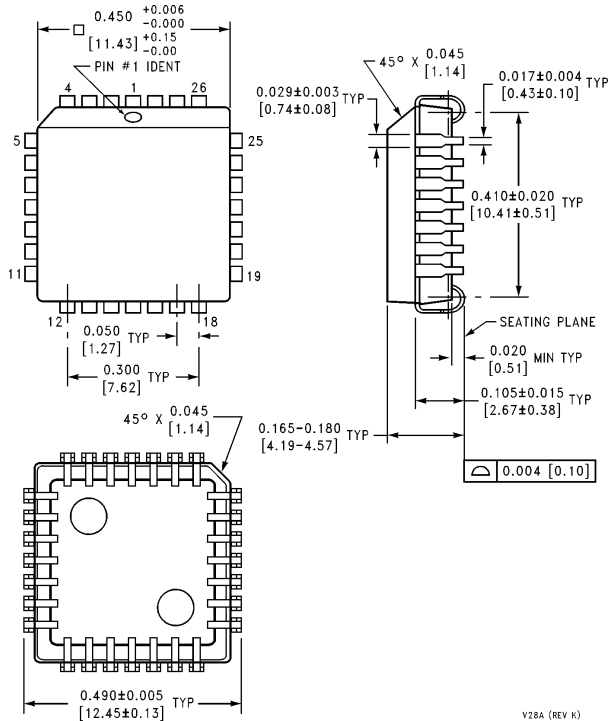

28-Lead Molded Plastic Leaded Chip Carrier (Q)
NS Package Number V28A

V28A (REV K)

LIFE SUPPORT POLICY

NATIONAL'S PRODUCTS ARE NOT AUTHORIZED FOR USE AS CRITICAL COMPONENTS IN LIFE SUPPORT DEVICES OR SYSTEMS WITHOUT THE EXPRESS WRITTEN APPROVAL OF THE PRESIDENT OF NATIONAL SEMICONDUCTOR CORPORATION. As used herein:

1. Life support devices or systems are devices or systems which, (a) are intended for surgical implant into the body, or (b) support or sustain life, and whose failure to perform, when properly used in accordance with instructions for use provided in the labeling, can be reasonably expected to result in a significant injury to the user.
2. A critical component is any component of a life support device or system whose failure to perform can be reasonably expected to cause the failure of the life support device or system, or to affect its safety or effectiveness.



National Semiconductor Corporation
1111 West Bardin Road
Arlington, TX 76017
Tel: 1(800) 272-9959
Fax: 1(800) 737-7018

National Semiconductor Europe
Fax: (+49) 0-180-530 85 86
Email: cnjwge@tevm2.nsc.com
Deutsch Tel: (+49) 0-180-530 85 85
English Tel: (+49) 0-180-532 78 32
Français Tel: (+49) 0-180-532 93 58
Italiano Tel: (+49) 0-180-534 16 80

National Semiconductor Hong Kong Ltd.
19th Floor, Straight Block,
Ocean Centre, 5 Canton Rd.
Tsimshatsui, Kowloon
Hong Kong
Tel: (852) 2737-1600
Fax: (852) 2736-9960

National Semiconductor Japan Ltd.
Tel: 81-043-299-2309
Fax: 81-043-299-2408

National does not assume any responsibility for use of any circuitry described, no circuit patent licenses are implied and National reserves the right at any time without notice to change said circuitry and specifications.

National Semiconductor was acquired by Texas Instruments.

http://www.ti.com/corp/docs/investor_relations/pr_09_23_2011_national_semiconductor.html

This file is the datasheet for the following electronic components:

74F525 - <http://www.ti.com/product/74f525?HQS=TI-null-null-dscatalog-df-pf-null-ww>



LittleDiode supplies new, hard to find or obsolete electronic components and semiconductors all over the world.

With over two million different components listed you are sure to find the part you need.

Feel free to visit us today at our online store:

LittleDiode.com

Looking forward to providing you with the best possible service.