

### FEATURES

- Operates at Supply Voltages From 1.0 V to 30 V
- Step-Up or Step-Down Mode
- Minimal External Components Required
- Low-Battery Detector
- User-Adjustable Current Limiting
- Fixed or Adjustable Output Voltage Versions
- 8-Pin DIP or SO-8 Package

### APPLICATIONS

- Cellular Telephones
- Single-Cell to 5 V Converters
- Laptop and Palmtop Computers
- Pagers
- Cameras
- Battery Backup Supplies
- Portable Instruments
- Laser Diode Drivers
- Hand-Held Inventory Computers

### GENERAL DESCRIPTION

The ADP1110 is part of a family of step-up/step-down switching regulators that operate from an input voltage supply as little as 1.0 V. This very low input voltage allows the ADP1110 to be used in applications that use a single cell as the primary power source.

The ADP1110 can be configured to operate in either step-up or step-down mode, but for input voltages greater than 3 V, the ADP1111 would be a more effective solution.

An auxiliary gain amplifier can serve as a low battery detector or as a linear regulator.

The quiescent current of 300  $\mu$ A makes the ADP1110 useful in remote or battery powered applications.

### FUNCTIONAL BLOCK DIAGRAMS

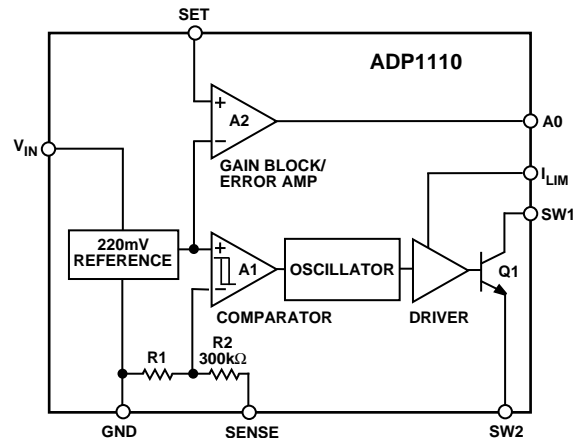

ADP1110 Block Diagram—Fixed Output Version

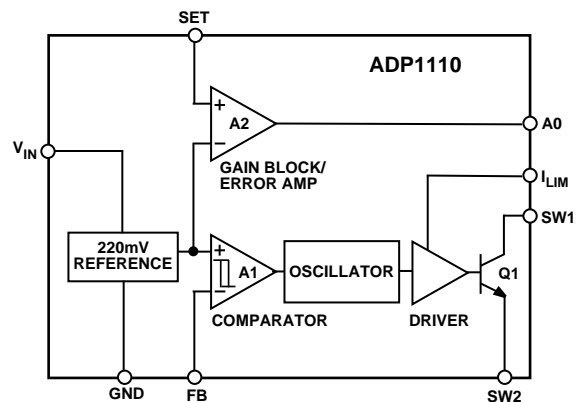

ADP1110 Block Diagram—Adjustable Output Version

The 70 kHz frequency operation also allows for the use of surface-mount external capacitors and inductors.

Battery protection circuitry limits the effect of reverse current to safe levels at reverse voltages up to 1.6 V.

### REV. 0

Information furnished by Analog Devices is believed to be accurate and reliable. However, no responsibility is assumed by Analog Devices for its use, nor for any infringements of patents or other rights of third parties which may result from its use. No license is granted by implication or otherwise under any patent or patent rights of Analog Devices.

# ADP1110—SPECIFICATIONS (0°C to +70°C, $V_{IN} = 1.5$ V unless otherwise noted)

Parameter	Conditions	$V_S$	Min	Typ	Max	Units
QUIESCENT CURRENT	Switch Off	$I_Q$		300		$\mu$ A
INPUT VOLTAGE	Step-Up Mode Step-Down Mode	$V_{IN}$	1.15		12.6 30	V V
COMPARATOR TRIP POINT VOLTAGE	ADP1110 <sup>1</sup>		210	220	230	mV
OUTPUT SENSE VOLTAGE	ADP1110-3.3 <sup>2</sup> ADP1110-5 <sup>2</sup> ADP1110-12 <sup>2</sup>	$V_{OUT}$	3.13 4.75 11.4	3.30 5.00 12.00	3.47 5.25 12.6	V V V
COMPARATOR HYSTERESIS	ADP1110			4	8	mV
OUTPUT HYSTERESIS	ADP1110-3.3 ADP1110-5 ADP1110-12			66 90 200	130 180 400	mV mV mV
OSCILLATOR FREQUENCY		$f_{OSC}$	52	70	90	kHz
DUTY CYCLE	Full Load ( $V_{FB} < V_{REF}$ )	DC	62	69	78	%
SWITCH ON TIME		$t_{ON}$	7.5	10	12.5	$\mu$ s
FEEDBACK PIN BIAS CURRENT	ADP1110 $V_{FB} = 0$ V	$I_{FB}$		150	240	nA
SET PIN BIAS CURRENT	$V_{SET} = V_{REF}$	$I_{SET}$		300	500	nA
A0 OUTPUT LOW	$I_{AO} = 300$ $\mu$ A $V_{SET} = 150$ mV	$V_{AO}$		0.15	0.4	V
REFERENCE LINE REGULATION	$1.0$ V $\leq V_{IN} \leq 1.5$ V $1.5$ V $\leq V_{IN} \leq 12$ V			0.35 0.05	0.1	%/V %/V
SWITCH SATURATION VOLTAGE STEP-UP MODE	$V_{IN} = 1.5$ V, $I_{SW} = 400$ mA, +25°C $T_{MIN}$ to $T_{MAX}$ $V_{IN} = 1.5$ V, $I_{SW} = 500$ mA, +25°C $T_{MIN}$ to $T_{MAX}$ $V_{IN} = 5$ V, $I_{SW} = 1$ A, +25°C	$V_{CESAT}$		300 400 700	500 600 650 750 1000	mV mV mV mV mV
A2 ERROR AMP GAIN	$R_L = 100$ k $\Omega$ <sup>3</sup>	$A_V$	1000	5000		V/V
REVERSE BATTERY CURRENT	$T_A = +25^\circ$ C <sup>4</sup>	$I_{REV}$		750		mA
CURRENT LIMIT TEMPERATURE COEFFICIENT	$V_{IN}, T_A = +25^\circ$ C			-0.3		%/°C
SWITCH OFF LEAKAGE CURRENT	Measured at SW1 Pin, $T_A = +25^\circ$ C	$I_{LEAK}$		1	10	$\mu$ A
MAXIMUM EXCURSION BELOW GND	$I_{SW1} \leq 10$ $\mu$ A, Switch Off $T_A = +25^\circ$ C	$V_{SW2}$		-400	-350	mV

## NOTES

<sup>1</sup>This specification guarantees that both the high and low trip point of the comparator fall within the 210 mV to 230 mV range.

<sup>2</sup>This specification guarantees that the output voltage of the fixed versions will always fall within the specified range. The waveform at the sense pin will exhibit a saw-tooth shape due to the comparator hysteresis.

<sup>3</sup>100 k $\Omega$  resistor connected between a 5 V source and the AO pin.

<sup>4</sup>The ADP1110 is guaranteed to withstand continuous application of +1.6 V applied to the GND and SW2 pins while  $V_{IN}$ ,  $I_{LIM}$ , and SW1 pins are grounded.

<sup>5</sup>All limits at temperature extremes are guaranteed via correlation using standard statistical quality control methods.

Specifications subject to change without notice.

## ABSOLUTE MAXIMUM RATINGS

Input Supply Voltage, Step-Up Mode	15 V
Input Supply Voltage, Step-Down Mode	36 V
SW1 Pin Voltage	50 V
SW2 Pin Voltage	-0.5 V to $V_{IN}$
Feedback Pin Voltage (ADP1110)	5.5 V
Switch Current	1.5 A
Maximum Power Dissipation	500 mW
Operating Temperature Range	0°C to +70°C
Storage Temperature Range	-65°C to 150°C
Lead Temperature (Soldering, 10 sec)	300°C

## PIN CONFIGURATIONS

### 8-Lead Plastic DIP (N-8)

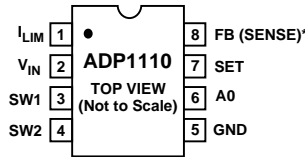

$T_{JMAX} = 90^{\circ}, \theta_{JA} = 130^{\circ}C/W$

\*FIXED VERSIONS

### 8-Lead SOIC (SO-8)

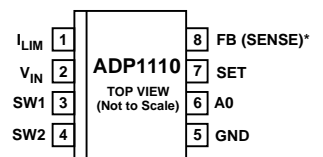

$T_{JMAX} = 90^{\circ}, \theta_{JA} = 150^{\circ}C/W$

\*FIXED VERSIONS

## TYPICAL APPLICATION

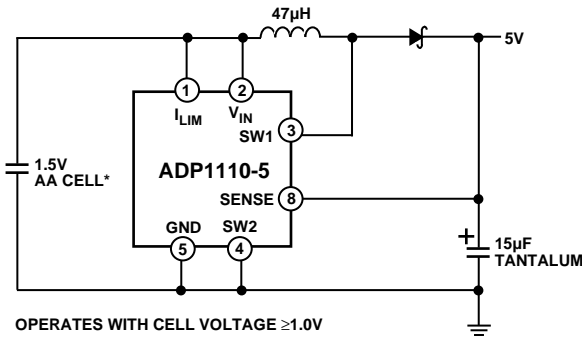

OPERATES WITH CELL VOLTAGE  $\geq 1.0V$

\*ADD 10µF DECOUPLING CAPACITOR IF BATTERY IS MORE THAN 2' AWAY FROM ADP1110.

Figure 1. 1.5 V to 5 V Converter

## ORDERING GUIDE

Model	Output Voltage	Package
ADP1110AN	ADJ	N-8
ADP1110AR	ADJ	SO-8
ADP1110AN-3.3	3.3 V	N-8
ADP1110AR-3.3	3.3 V	SO-8
ADP1110AN-5	5 V	N-8
ADP1110AR-5	5 V	SO-8
ADP1110AN-12	12 V	N-8
ADP1110AR-12	12 V	SO-8

## PIN DESCRIPTION

Mnemonic	Function
$I_{LIM}$	For normal conditions this pin is connected to $V_{IN}$ . When lower current is required, a resistor should be connected between $I_{LIM}$ and $V_{IN}$ . Limiting the switch current to 400 mA is achieved by connecting a 220 $\Omega$ resistor.
$V_{IN}$	Input Voltage.
SW1	Collector Node of Power Transistor. For step-down configuration, connect to $V_{IN}$ . For step-up configuration, connect to an inductor/diode.
SW2	Emitter Node of Power Transistor. For step-down configuration, connect to inductor/diode. For step-up configuration, connect to ground. Do not allow this pin to go more than a diode drop below ground.
GND	Ground.
AO	Auxiliary Gain (GB) Output. The open collector can sink 300 $\mu A$ . It can be left open if unused.
SET	Gain Amplifier Input. The amplifier has positive input connected to SET pin and negative input connected to 220 mV reference. It can be left open if unused.
FB/SENSE	On the ADP1110 (adjustable) version this pin is connected to the comparator input. On the ADP1110-3.3, ADP1110-5 and ADP1110-12, the pin goes directly to the internal application resistor that set output voltage.

## CAUTION

ESD (electrostatic discharge) sensitive device. Electrostatic charges as high as 4000 V readily accumulate on the human body and test equipment and can discharge without detection. Although the ADP1110 features proprietary ESD protection circuitry, permanent damage may occur on devices subjected to high energy electrostatic discharges. Therefore, proper ESD precautions are recommended to avoid performance degradation or loss of functionality.



# ADP1110-Typical Characteristics

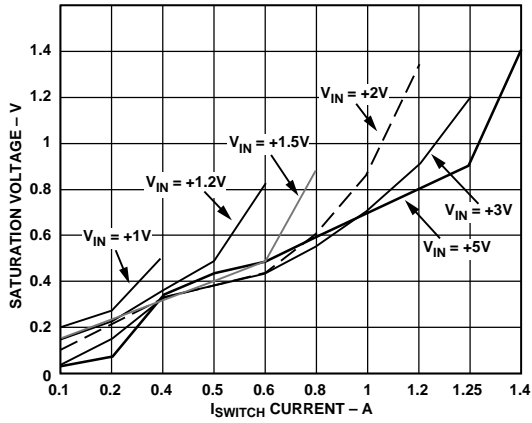

Figure 2. Saturation Voltage vs.  $I_{SWITCH}$  Current in Step-Up Mode

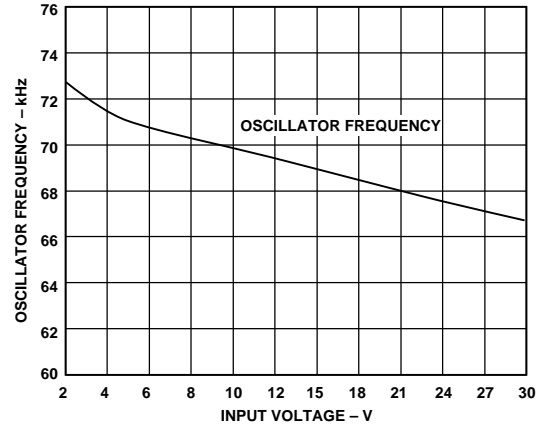

Figure 5. Oscillator Frequency vs. Input Voltage

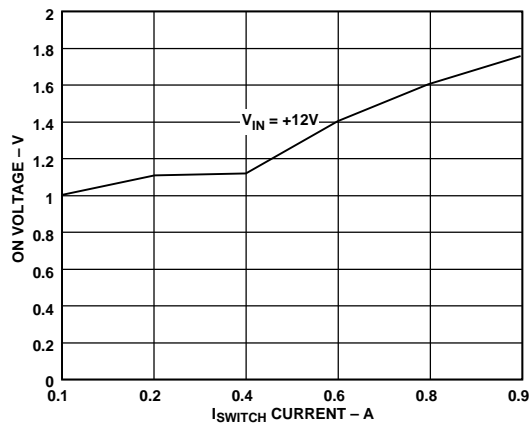

Figure 3. Switch ON Voltage vs.  $I_{SWITCH}$  Current In Step-Down Mode

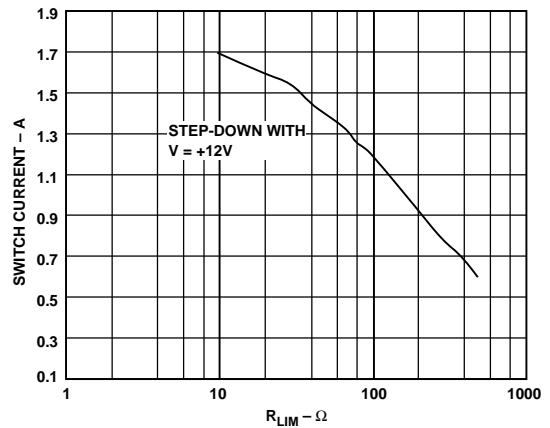

Figure 6. Maximum Switch Current vs.  $R_{LIM}$

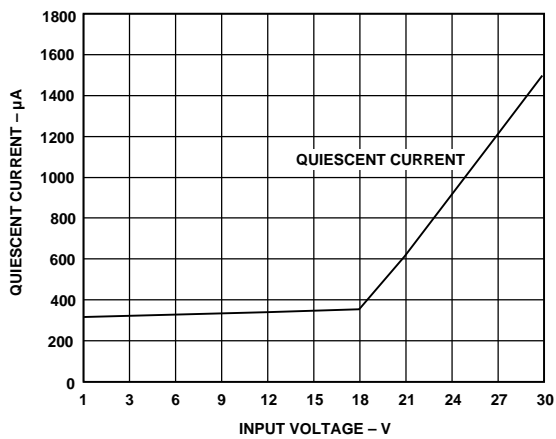

Figure 4. Quiescent Current vs. Input Voltage

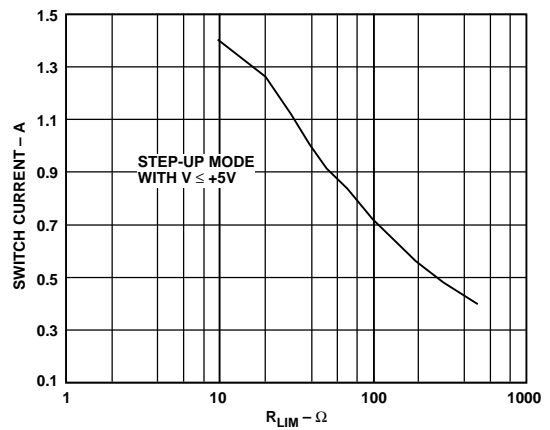

Figure 7. Maximum Switch Current vs.  $R_{LIM}$

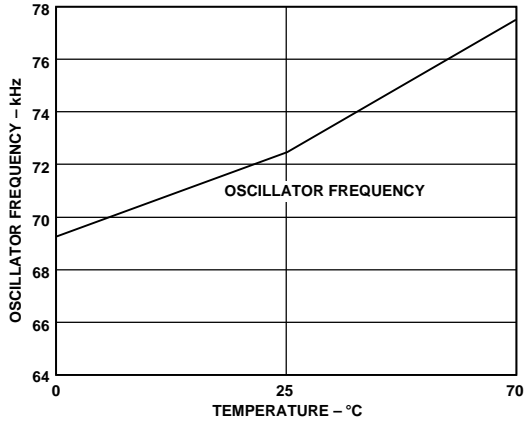

Figure 8. Oscillator Frequency vs. Temperature

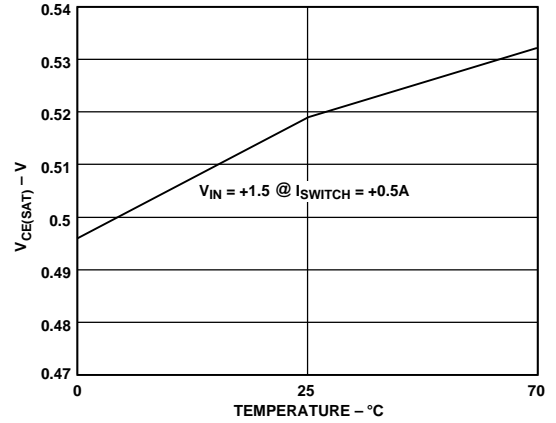

Figure 11. Switch ON Voltage Step-Down vs. Temperature

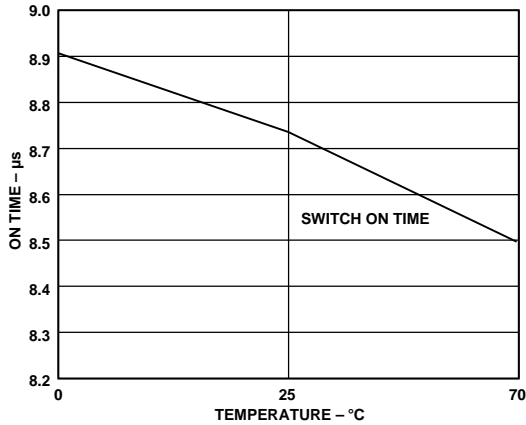

Figure 9. Switch ON Time vs. Temperature

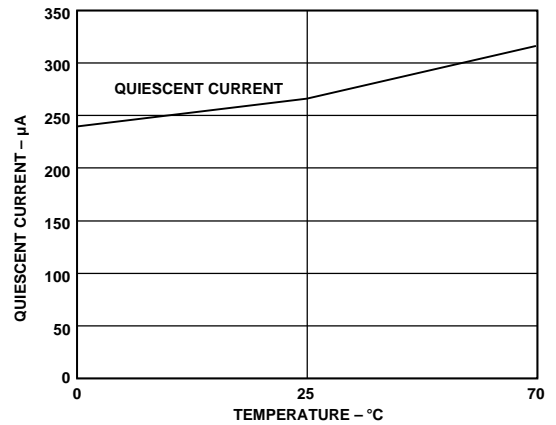

Figure 12. Quiescent Current vs. Temperature

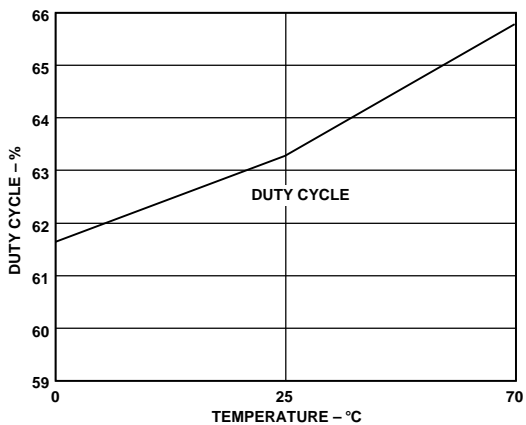

Figure 10. Duty Cycle vs. Temperature

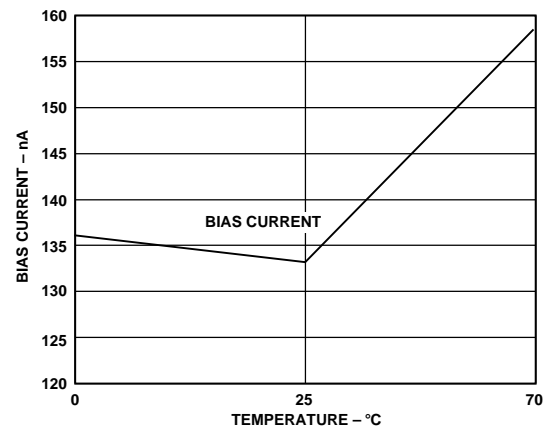

Figure 13. FB Pin Bias Current vs. Temperature

# ADP1110

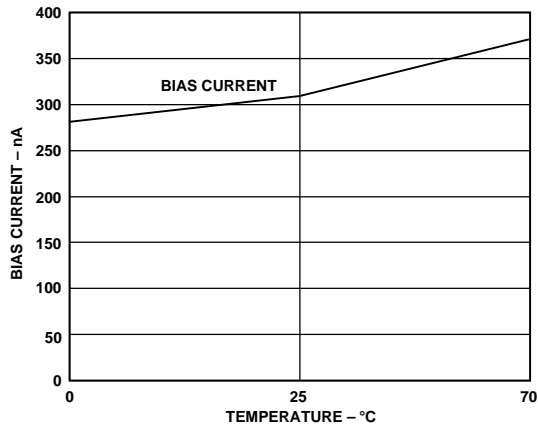

Figure 14. Set Pin Bias Current vs. Temperature

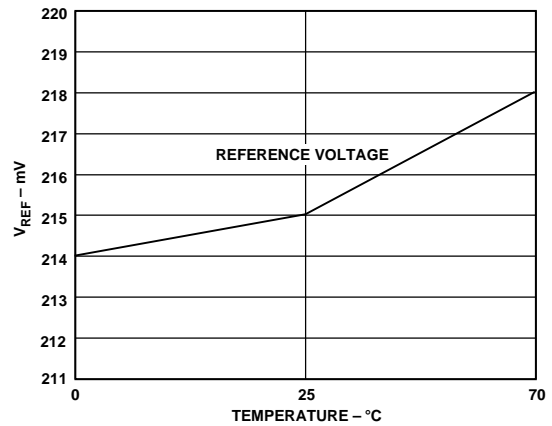

Figure 15. Reference Voltage vs. Temperature

## THEORY OF OPERATION

The ADP1110 is a flexible, low-power, switch-mode power supply (SMPS) controller. The regulated output voltage can be greater than the input voltage (boost or step-up mode) or less than the input (buck or step-down mode). This device uses a gated-oscillator technique to provide very high performance with low quiescent current.

A functional block diagram of the ADP1110 is shown on the first page. The internal 220 mV reference is connected to one input of the comparator, while the other input is externally connected (via the FB pin) to a feedback network connected to the regulated output. When the voltage at the FB pin falls below 220 mV, the 70 kHz oscillator turns on. A driver amplifier provides base drive to the internal power switch, and the switching action raises the output voltage. When the voltage at the FB pin exceeds 220 mV, the oscillator is shut off. While the oscillator is off, the ADP1110 quiescent current is only 300  $\mu$ A. The comparator includes a small amount of hysteresis, which ensures loop stability without requiring external components for frequency compensation.

The maximum current in the internal power switch can be set by connecting a resistor between  $V_{IN}$  and the  $I_{LIM}$  pin. When the maximum current is exceeded, the switch is turned OFF. The current limit circuitry has a time delay of about 800 ns. If an external resistor is not used, connect  $I_{LIM}$  to  $V_{IN}$ . Further information on  $I_{LIM}$  is included in the “Applications” section of this data sheet.

The ADP1110 internal oscillator provides 10  $\mu$ s ON and 5  $\mu$ s OFF times, which is ideal for applications where the ratio between  $V_{IN}$  and  $V_{OUT}$  is roughly a factor of three (such as generating +5 V from a single 1.5 V cell). Wider range conversions, as well as step-down converters, can also be accomplished with a slight loss in the maximum output power that can be obtained.

An uncommitted gain block on the ADP1110 can be connected as a low-battery detector. The inverting input of the gain block is internally connected to the 220 mV reference. The noninverting input is available at the SET pin. A resistor divider, connected between  $V_{IN}$  and GND with the junction connected to the SET pin, causes the AO output to go LOW when the low battery set point is exceeded. The AO output is an open collector NPN transistor that can sink 300  $\mu$ A.

The ADP1110 provides external connections for both the collector and emitter of its internal power switch, which permits

both step-up and step-down modes of operation. For the step-up mode, the emitter (Pin SW2) is connected to GND and the collector (Pin SW1) drives the inductor. For step-down mode, the emitter drives the inductor while the collector is connected to  $V_{IN}$ .

The output voltage of the ADP1110 is set with two external resistors. Three fixed-voltage models are also available: ADP1110-3.3 (+3.3 V), ADP1110-5 (+5 V) and ADP1110-12 (+12 V). The fixed-voltage models are identical to the ADP1110 except that laser-trimmed voltage-setting resistors are included on the chip. Only three external components are required to form a +3.3 V, +5 V or +12 V converter. On the fixed-voltage models of the ADP1110, simply connect the SENSE pin (Pin 8) directly to the output voltage.

## COMPONENT SELECTION

### General Notes on Inductor Selection

When the ADP1110 internal power switch turns on, current begins to flow in the inductor. Energy is stored in the inductor core while the switch is on, and this stored energy is then transferred to the load when the switch turns off. Because both the collector and the emitter of the switch transistor are accessible on the ADP1110, the output voltage can be higher, lower, or of opposite polarity than the input voltage.

To specify an inductor for the ADP1110, the proper values of inductance, saturation current, and DC resistance must be determined. This process is not difficult, and specific equations for each circuit configuration are provided in this data sheet. In general terms, however, the inductance value must be low enough to store the required amount of energy (when both input voltage and switch ON time are at a minimum) but high enough that the inductor will not saturate when both  $V_{IN}$  and switch ON time are at their maximum values. The inductor must also store enough energy to supply the load without saturating. Finally, the dc resistance of the inductor should be low so that excessive power will not be wasted by heating the windings. For most ADP1110 applications, an inductor of 15  $\mu$ H to 100  $\mu$ H with a saturation current rating of 300 mA to 1A and dc resistance <0.4  $\Omega$  is suitable. Ferrite-core inductors that meet these specifications are available in small, surface-mount packages.

To minimize Electro-Magnetic Interference (EMI), a toroid or pot-core type inductor is recommended. Rod-core inductors are a lower-cost alternative if EMI is not a problem.

## CALCULATING THE INDUCTOR VALUE

Selecting the proper inductor value is a simple three-step process:

1. Define the operating parameters: minimum input voltage, maximum input voltage, output voltage and output current.
2. Select the appropriate conversion topology (step-up, step-down, or inverting).
3. Calculate the inductor value, using the equations in the following sections.

## INDUCTOR SELECTION-STEP-UP CONVERTER

In a step-up or boost converter (Figure 19), the inductor must store enough power to make up the difference between the input voltage and the output voltage. The power that must be stored is calculated from the equation:

$$P_L = (V_{OUT} + V_D - V_{IN(MIN)}) \cdot (I_{OUT}) \quad (\text{Equation 1})$$

where  $V_D$  is the diode forward voltage ( $\approx 0.5$  V for a 1N5818 Schottky). Because energy is only stored in the inductor while the ADP1110 switch is ON, the energy stored in the inductor on each switching cycle must be equal to or greater than:

$$\frac{P_L}{f_{OSC}} \quad (\text{Equation 2})$$

in order for the ADP1110 to regulate the output voltage.

When the internal power switch turns ON, current flow in the inductor increases at the rate of:

$$I_L(t) = \frac{V_{IN}}{R'} \left( 1 - e^{-\frac{Rt}{L}} \right) \quad (\text{Equation 3})$$

where  $L$  is in Henrys and  $R'$  is the sum of the switch equivalent resistance (typically  $0.8 \Omega$  at  $+25^\circ\text{C}$ ) and the dc resistance of the inductor. If the voltage drop across the switch is small compared to  $V_{IN}$ , a simpler equation can be used:

$$I_L(t) = \frac{V_{IN}}{L} t \quad (\text{Equation 4})$$

Replacing ' $t$ ' in the above equation with the ON time of the ADP1110 ( $10 \mu\text{s}$ , typical) will define the peak current for a given inductor value and input voltage. At this point, the inductor energy can be calculated as follows:

$$E_L = \frac{1}{2} L \cdot I_{PEAK}^2 \quad (\text{Equation 5})$$

As previously mentioned,  $E_L$  must be greater than  $P_L/f_{OSC}$  so that the ADP1110 can deliver the necessary power to the load. For best efficiency, peak current should be limited to 1 A or less. Higher switch currents will reduce efficiency because of increased saturation voltage in the switch. High peak current also increases output ripple. As a general rule, keep peak current as low as possible to minimize losses in the switch, inductor and diode.

In practice, the inductor value is easily selected using the equations above. For example, consider a supply that will generate 12 V at 120 mA from a 4.5 V to 8 V source. The inductor power required is from Equation 1:

$$P_L = (12 \text{ V} + 0.5 \text{ V} - 4.5 \text{ V}) \cdot 120 \text{ mA} = 960 \text{ mW}$$

On each switching cycle, the inductor must supply:

$$\frac{P_L}{f_{OSC}} = \frac{960 \text{ mW}}{70 \text{ kHz}} = 13.7 \mu\text{J}$$

Assuming a peak current of 1 A as a starting point, (Equation 4) can be rearranged to recommend an inductor value:

$$L = \frac{V_{IN}}{I_{L(MAX)}} t = \frac{4.5 \text{ V}}{1 \text{ A}} 10 \mu\text{s} = 45 \mu\text{H}$$

Substituting a standard inductor value of  $47 \mu\text{H}$  with  $0.2 \Omega$  dc resistance will produce a peak switch current of:

$$I_{PEAK} = \frac{4.5 \text{ V}}{1.0 \Omega} \left( 1 - e^{-\frac{-1.0 \Omega \cdot 10 \mu\text{s}}{47 \mu\text{H}}} \right) = 862 \text{ mA}$$

Once the peak current is known, the inductor energy can be calculated from Equation 5:

$$E_L = \frac{1}{2} (47 \mu\text{H}) \cdot (862 \text{ mA})^2 = 17.5 \mu\text{J}$$

Since the inductor energy of  $17.5 \mu\text{J}$  is greater than the  $P_L/f_{OSC}$  requirement of  $13.7 \mu\text{J}$ , the  $47 \mu\text{H}$  inductor will work in this application. By substituting other inductor values into the same equations, the optimum inductor value can be determined. When selecting an inductor, the peak current must not exceed the maximum switch current of 1.5 A.

The peak current must be evaluated for both minimum and maximum values of input voltage. If the switch current is high when  $V_{IN}$  is at its minimum, the 1.5 A limit may be exceeded at the maximum value of  $V_{IN}$ . In this case, the ADP1110's current limit feature can be used to limit switch current. Simply select a resistor (using Figure 7) that will limit the maximum switch current to the  $I_{PEAK}$  value calculated for the minimum value of  $V_{IN}$ . This will improve efficiency by producing a constant  $I_{PEAK}$  as  $V_{IN}$  increases. See the "Limiting the Switch Current" section of this data sheet for more information.

Note that the switch current limit feature does not protect the circuit if the output is shorted to ground. In this case, current is only limited by the dc resistance of the inductor and the forward voltage of the diode.

## INDUCTOR SELECTION-STEP-DOWN CONVERTER

The step-down mode of operation is shown in Figure 20.

Unlike the step-up mode, the ADP1110's power switch does not saturate when operating in the step-down mode; therefore, switch current should be limited to 800 mA in this mode. If the input voltage will vary over a wide range, the  $I_{LIM}$  pin can be used to limit the maximum switch current. Higher switch current is possible by adding an external switching transistor as shown in Figure 22.

The first step in selecting the step-down inductor is to calculate the peak switch current as follows:

$$I_{PEAK} = \frac{2 I_{OUT}}{DC} \left( \frac{V_{OUT} + V_D}{V_{IN} - V_{SW} + V_D} \right) \quad (\text{Equation 6})$$

where:  $DC$  = duty cycle (0.69 for the ADP1110)

$V_{SW}$  = voltage drop across the switch

$V_D$  = diode drop (0.5 V for a 1N5818)

$I_{OUT}$  = output current

$V_{OUT}$  = the output voltage

$V_{IN}$  = the minimum input voltage

# ADP1110

As previously mentioned, the switch voltage is higher in step-down mode than in step-up mode.  $V_{SW}$  is a function of switch current and is therefore a function of  $V_{IN}$ ,  $L$ , time and  $V_{OUT}$ . For most applications, a  $V_{SW}$  value of 1.5 V is recommended.

The inductor value can now be calculated:

$$L = \frac{V_{IN(MIN)} - V_{SW} - V_{OUT}}{I_{PEAK}} \cdot t_{ON} \quad (\text{Equation 7})$$

where:  $t_{ON}$  = Switch ON time (10  $\mu$ s)

If the input voltage will vary (such as an application that must operate from a 9 V, 12 V or 15 V source), an  $R_{LIM}$  resistor should be selected from Figure 6. The  $R_{LIM}$  resistor will keep switch current constant as the input voltage rises. Note that there are separate  $R_{LIM}$  values for step-up and step-down modes of operation.

For example, assume that +5 V at 250 mA is required from a +9 V to +18 V source. Deriving the peak current from Equation 6 yields:

$$I_{PEAK} = \frac{2 \cdot 250 \text{ mA}}{0.69} \left( \frac{5 + 0.5}{9 - 1.5 + 0.5} \right) = 498 \text{ mA}$$

Then, the peak current can be inserted into Equation 7 to calculate the inductor value:

$$L = \frac{9 - 1.5 - 5}{498 \text{ mA}} \cdot 10 \mu\text{s} = 50 \mu\text{s}$$

Since 50  $\mu$ H is not a standard value, the next lower standard value of 47  $\mu$ H would be specified.

To avoid exceeding the maximum switch current when the input voltage is at +18 V, an  $R_{LIM}$  resistor should be specified. Using the step-down curve of Figure 6, a value of 560  $\Omega$  will limit the switch current to 500 mA.

## INDUCTOR SELECTION—POSITIVE-TO-NEGATIVE CONVERTER

The configuration for a positive-to-negative converter using the ADP1110 is shown in Figure 23. As with the step-up converter, all of the output power for the inverting circuit must be supplied by the inductor. The required inductor power is derived from the formula:

$$P_L = (|V_{OUT}| + V_D) \cdot (I_{OUT}) \quad (\text{Equation 8})$$

The ADP1110 power switch does not saturate in positive-to-negative mode. The voltage drop across the switch can be modeled as a 0.75 V base-emitter diode in series with a 0.65  $\Omega$  resistor. When the switch turns on, inductor current will rise at a rate determined by:

$$I_L(t) = \frac{V_L}{R'} \left( 1 - e^{-\frac{R't}{L}} \right) \quad (\text{Equation 9})$$

where:  $R' = 0.65 \Omega + R_{L(DC)}$   
 $V_L = V_{IN} - 0.75 \text{ V}$

For example, assume that a -5 V output at 75 mA is to be generated from a +4.5 V to +5.5 V source. The power in the inductor is calculated from Equation 8:

$$P_L = (|-5 \text{ V}| + 0.5 \text{ V}) \cdot (75 \text{ mA}) = 413 \text{ mW}$$

During each switching cycle, the inductor must supply the following energy:

$$\frac{P_L}{f_{OSC}} = \frac{413 \text{ mW}}{70 \text{ kHz}} = 5.9 \mu\text{J}$$

Using a standard inductor value of 56  $\mu$ H with 0.2  $\Omega$  dc resistance will produce a peak switch current of:

$$I_{PEAK} = \frac{4.5 \text{ V} - 0.75 \text{ V}}{0.65 \Omega + 0.2 \Omega} \left( 1 - e^{-\frac{0.85 \Omega \cdot 10 \mu\text{s}}{56 \mu\text{H}}} \right) = 621 \text{ mA}$$

Once the peak current is known, the inductor energy can be calculated from Equation 9:

$$E_L = \frac{1}{2} (56 \mu\text{H}) \cdot (621 \text{ mA})^2 = 10.8 \mu\text{J}$$

Since the inductor energy of 10.8  $\mu$ J is greater than the  $P_L/f_{OSC}$  requirement of 5.9  $\mu$ J, the 56  $\mu$ H inductor will work in this application.

The input voltage only varies between 4.5 V and 5.5 V in this example. Therefore, the peak current will not change enough to require an  $R_{LIM}$  resistor and the  $I_{LIM}$  pin can be connected directly to  $V_{IN}$ . Care should be taken, of course, to ensure that the peak current does not exceed 800 mA.

## CAPACITOR SELECTION

For optimum performance, the ADP1110's output capacitor must be selected carefully. Choosing an inappropriate capacitor can result in low efficiency and/or high output ripple.

Ordinary aluminum electrolytic capacitors are inexpensive but often have poor Equivalent Series Resistance (ESR) and Equivalent Series Inductance (ESL). Low ESR aluminum capacitors, specifically designed for switch mode converter applications, are also available, and these are a better choice than general purpose devices. Even better performance can be achieved with tantalum capacitors, although their cost is higher. Very low values of ESR can be achieved by using OS-CON capacitors (Sanyo Corporation, San Diego, CA). These devices are fairly small, available with tape-and-reel packaging and have very low ESR.

The effects of capacitor selection on output ripple are demonstrated in Figures 16, 17 and 18. These figures show the output of the same ADP1110 converter, that was evaluated with three different output capacitors. In each case, the peak switch current is 500 mA, and the capacitor value is 100  $\mu$ F. Figure 16 shows a Panasonic HF-series 16-volt radial cap. When the switch turns off, the output voltage jumps by about 90 mV and then decays as the inductor discharges into the capacitor. The rise in voltage indicates an ESR of about 0.18  $\Omega$ . In Figure 17, the aluminum electrolytic has been replaced by a Sprague 293D series, a 6 V tantalum device. In this case the output jumps

about 30 mV, which indicates an ESR of 0.06 Ω. Figure 18 shows an OS-CON 16-volt capacitor in the same circuit, and ESR is only 0.02 Ω.

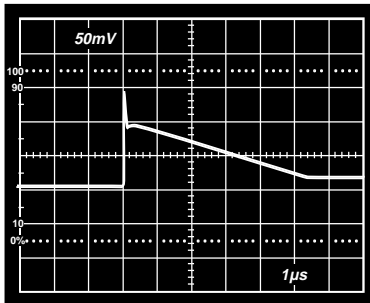

Figure 16. Aluminum Electrolytic

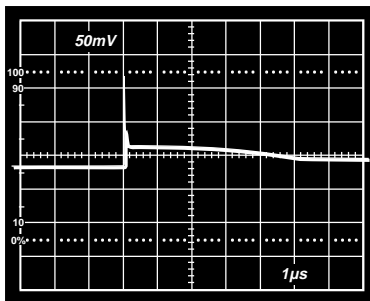

Figure 17. Tantalum Electrolytic

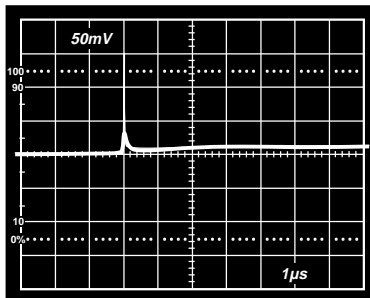

Figure 18. OS-CON Capacitor

If low output ripple is important, the user should consider the ADP3000. Because this device switches at 400 kHz, lower peak current can be used. Also, the higher switching frequency simplifies the design of the output filter. Consult the ADP3000 data sheet for additional details.

### DIODE SELECTION

In specifying a diode, consideration must be given to speed, forward voltage drop and reverse leakage current. When the ADP1110 switch turns off, the diode must turn on rapidly if high efficiency is to be maintained. Schottky rectifiers, as well as fast signal diodes such as the 1N4148, are appropriate. The forward voltage of the diode represents power that is not delivered to the load, so  $V_F$  must also be minimized. Again, Schottky diodes are recommended. Leakage current is especially

important in low-current applications, where the leakage can be a significant percentage of the total quiescent current.

For most circuits, the 1N5818 is a suitable companion to the ADP1110. This diode has a  $V_F$  of 0.5 V at 1 A, 4 μA to 10 μA leakage, and fast turn-on and turn-off times. A surface mount version, the MBR5130LT3, is also available.

For switch currents of 100 mA or less, a Schottky diode such as the BAT85 provides a  $V_F$  of 0.8 V at 100 mA and leakage less than 1 μA. A similar device, the BAT54, is available in a SOT23 package. Even lower leakage, in the 1 nA to 5 nA range, can be obtained with a 1N4148 signal diode.

General purpose rectifiers, such as the 1N4001, are not suitable for ADP1110 circuits. These devices, which have turn-on times of 10 μs or more, are too slow for switching power supply applications. Using such a diode “just to get started” will result in wasted time and effort. Even if an ADP1110 circuit appears to function with a 1N4001, the resulting performance will not be indicative of the circuit performance when the correct diode is used.

### CIRCUIT OPERATION, STEP-UP (BOOST) MODE

In boost mode, the ADP1110 produces an output voltage that is higher than the input voltage. For example, +5 V can be derived from one alkaline cell (+1.5 V), or +12 V can be generated from a +5 V logic power supply.

Figure 19 shows an ADP1110 configured for step-up operation. The collector of the internal power switch is connected to the output side of the inductor, while the emitter is connected to GND. When the switch turns on, pin SW1 is pulled near ground. This action forces a voltage across L1 equal to  $V_{IN} - V_{CE(SAT)}$ , and current begins to flow through L1. This current reaches a final value (ignoring second-order effects) of:

$$I_{PEAK} \cong \frac{V_{IN} - V_{CE(SAT)}}{L} \cdot 10 \mu s$$

where 10 μs is the ADP1110 switch’s “on” time.

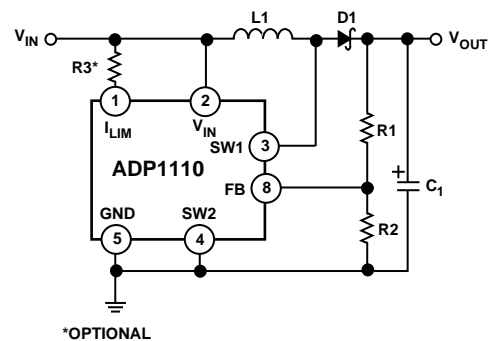

Figure 19. Step-Up Mode Operation

When the switch turns off, the magnetic field collapses. The polarity across the inductor changes, current begins to flow through D1 into the load, and the output voltage is driven above the input voltage.

The output voltage is fed back to the ADP1110 via resistors R1 and R2. When the voltage at pin FB falls below 220 mV, SW1

# ADP1110

turns “on” again, and the cycle repeats. The output voltage is therefore set by the formula:

$$V_{OUT} = 220\text{ mV} \cdot \left(1 + \frac{R1}{R2}\right)$$

The circuit of Figure 19 shows a direct current path from  $V_{IN}$  to  $V_{OUT}$ , via the inductor and D1. Therefore, the boost converter is not protected if the output is short circuited to ground.

## CIRCUIT OPERATION, STEP-DOWN (BUCK) MODE

The ADP1110’s step-down mode is used to produce an output voltage that is lower than the input voltage. For example, the output of four NiCd cells (+4.8 V) can be converted to a +3 V logic supply.

A typical configuration for step-down operation of the ADP1110 is shown in Figure 20. In this case, the collector of the internal power switch is connected to  $V_{IN}$  and the emitter drives the inductor. When the switch turns on, SW2 is pulled up towards  $V_{IN}$ . This forces a voltage across L1 equal to  $V_{IN} - V_{CE} - V_{OUT}$  and causes current to flow in L1. This current reaches a final value of:

$$I_{PEAK} \cong \frac{V_{IN} - V_{CE} - V_{OUT}}{L} \cdot 10\ \mu\text{s}$$

where  $10\ \mu\text{s}$  is the ADP1110 switch’s “on” time.

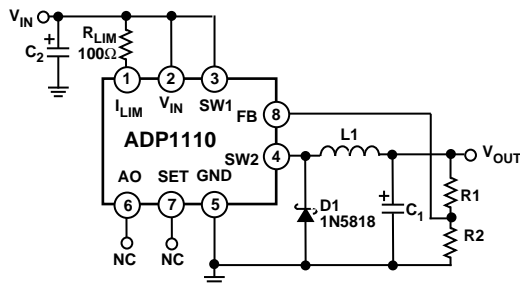

Figure 20. Step-Down Mode Operation

When the switch turns off, the magnetic field collapses. The polarity across the inductor changes, and the switch side of the inductor is driven below ground. Schottky diode D1 then turns on, and current flows into the load. Notice that the Absolute Maximum Rating for the ADP1110’s SW2 pin is 0.5 V below ground. To avoid exceeding this limit, D1 must be a Schottky diode. Using a silicon diode in this application will generate forward voltages above 0.5 V that will cause potentially damaging power dissipation within the ADP1110.

The output voltage of the buck regulator is fed back to the ADP1110’s FB pin by resistors R1 and R2. When the voltage at pin FB falls below 220 mV, the internal power switch turns “on” again and the cycle repeats. The output voltage is set by the formula:

$$V_{OUT} = 220\text{ mV} \cdot \left(1 + \frac{R1}{R2}\right)$$

When operating the ADP1110 in step-down mode, the output voltage is impressed across the internal power switch’s emitter-

base junction when the switch is off. To protect the switch, the output voltage should be limited to 6.2 V or less. If a higher output voltage is required, a Schottky diode should be placed in series with SW2, as shown in Figure 21.

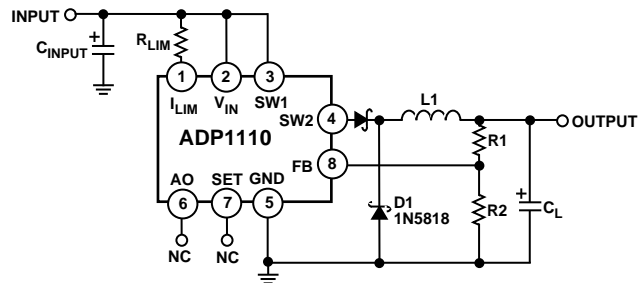

Figure 21. Step-Down Mode,  $V_{OUT} > 6.2\text{ V}$

If the input voltage to the ADP1110 varies over a wide range, a current limiting resistor at Pin 1 may be required. If a particular circuit requires high peak inductor current with minimum input supply voltage, the peak current may exceed the switch maximum rating and/or saturate the inductor when the supply voltage is at the maximum value. See the “Limiting the Switch Current” section of this data sheet for specific recommendations.

## INCREASING OUTPUT CURRENT IN THE STEP-DOWN REGULATOR

Unlike the boost configuration, the ADP1110’s internal power switch is not saturated when operating in step-down mode. A conservative value for the voltage across the switch in step-down mode is 1.5 V. This results in high power dissipation within the ADP1110 when high peak current is required. To increase the output current, an external PNP switch can be added (Figure 22). In this circuit, the ADP1110 provides base drive to Q1 through R3, while R4 ensures that Q1 turns off rapidly. Because the ADP1110’s internal current limiting function will not work in this circuit, R5 is provided for this purpose. With the value shown, R5 limits current to 2 A. In addition to reducing power dissipation on the ADP1110, this circuit also reduces the switch voltage. When selecting an inductor value for the circuit of Figure 22, the switch voltage can be calculated from the formula:

$$V_{SW} = V_{R5} + V_{Q1(SAT)} \cong 0.6\text{ V} + 0.4\text{ V} \cong 1\text{ V}$$

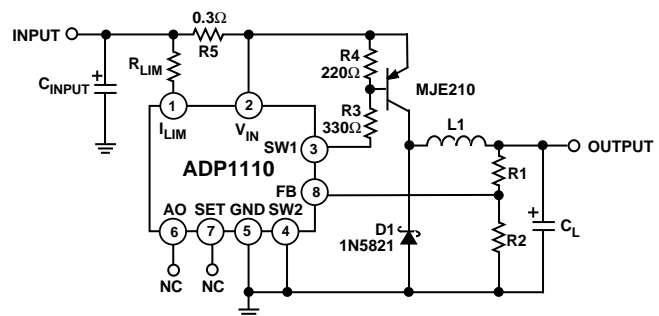

Figure 22. High Current Step-Down Operation

## POSITIVE-TO-NEGATIVE CONVERSION

The ADP1110 can convert a positive input voltage to a negative output voltage as shown in Figure 23. This circuit is essentially identical to the step-down application of Figure 19, except that the “output” side of the inductor is connected to power ground. When the ADP1110’s internal power switch turns off, current flowing in the inductor forces the output ( $-V_{OUT}$ ) to a negative potential. The ADP1110 will continue to turn the switch on until its FB pin is 220 mV above its GND pin, so the output voltage is determined by the formula:

$$V_{OUT} = 220 \text{ mV} \cdot \left(1 + \frac{R1}{R2}\right)$$

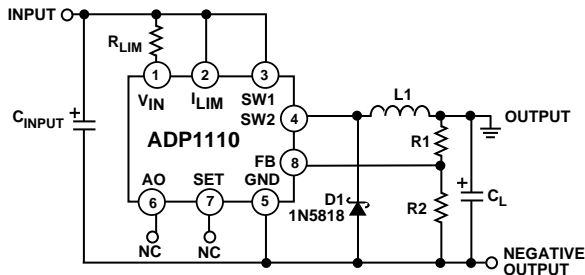

Figure 23. A Positive-to-Negative Converter

The design criteria for the step-down application also apply to the positive-to-negative converter. The output voltage should be limited to  $|6.2 \text{ V}|$  unless a diode is inserted in series with the SW2 pin (see Figure 21.) Also, D1 must again be a Schottky diode to prevent excessive power dissipation in the ADP1110.

## NEGATIVE-TO-POSITIVE CONVERSION

The circuit of Figure 24 converts a negative input voltage to a positive output voltage. Operation of this circuit configuration is similar to the step-up topology of Figure 19, except the current through feedback resistor R1 is level-shifted below ground by a PNP transistor. The voltage across R1 is  $V_{OUT} - V_{BEQ1}$ . However, diode D2 level-shifts the base of Q1 about 0.6 V below ground thereby cancelling the  $V_{BE}$  of Q1. The addition of D2 also reduces the circuit’s output voltage sensitivity to temperature, which otherwise would be dominated by the  $-2 \text{ mV } V_{BE}$  contribution of Q1. The output voltage for this circuit is determined by the formula:

$$V_{OUT} = 220 \text{ mV} \cdot \left(\frac{R1}{R2}\right)$$

Unlike the positive step-up converter, the negative-to-positive converter’s output voltage can be either higher or lower than the input voltage.

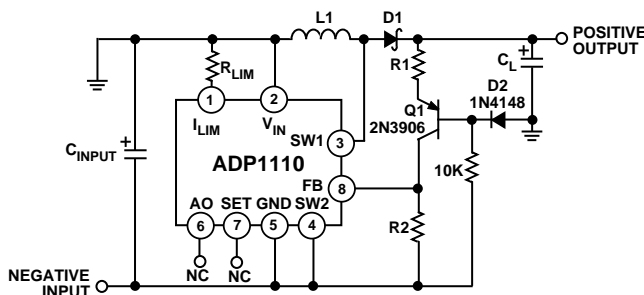

Figure 24. A Negative-to-Positive Converter

## LIMITING THE SWITCH CURRENT

The ADP1110’s  $R_{LIM}$  pin permits the switch current to be limited with a single resistor. This current limiting action occurs on a pulse by pulse basis. This feature allows the input voltage to vary over a wide range without saturating the inductor or exceeding the maximum switch rating. For example, a particular design may require peak switch current of 800 mA with a 2.0 V input. If  $V_{IN}$  rises to 4 V, however, the switch current will exceed 1.6 A. The ADP1110 limits switch current to 1.5 A and thereby protects the switch, but the output ripple will increase. Selecting the proper resistor will limit the switch current to 800 mA, even if  $V_{IN}$  increases. The relationship between  $R_{LIM}$  and maximum switch current is shown in Figure 6.

The  $I_{LIM}$  feature is also valuable for controlling inductor current when the ADP1110 goes into continuous-conduction mode. This occurs in the step-up mode when the following condition is met:

$$\left(\frac{V_{OUT} + V_{DIODE}}{V_{IN} - V_{SW}}\right) < \frac{1}{1 - DC}$$

where DC is the ADP1110’s duty cycle. When this relationship exists, the inductor current does not go all the way to zero during the time that the switch is OFF. When the switch turns on for the next cycle, the inductor current begins to ramp up from the residual level. If the switch ON time remains constant, the inductor current will increase to a high level (see Figure 25). This increases output ripple and can require a larger inductor and capacitor. By controlling switch current with the  $I_{LIM}$  resistor, output ripple current can be maintained at the design values. Figure 26 illustrates the action of the  $I_{LIM}$  circuit.

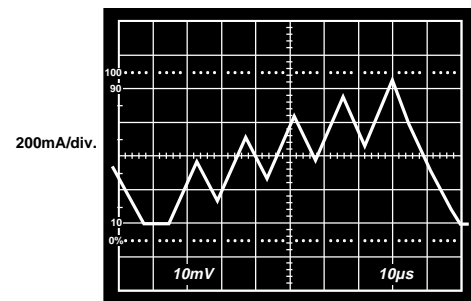

Figure 25.  $I_{LIM}$  Operation— $I_L$  Characteristic

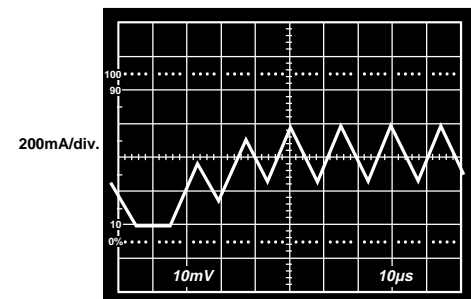

Figure 26.  $I_{LIM}$  Operation— $I_L$  Characteristic

# ADP1110

The internal structure of the  $I_{LIM}$  circuit is shown in Figure 27. Q1 is the ADP1110's internal power switch, that is paralleled by sense transistor Q2. The relative sizes of Q1 and Q2 are scaled so that  $I_{Q2}$  is 0.5% of  $I_{Q1}$ . Current flows to Q2 through an internal  $80\ \Omega$  resistor and through the  $R_{LIM}$  resistor. These two resistors parallel the base-emitter junction of the oscillator-disable transistor, Q3. When the voltage across R1 and  $R_{LIM}$  exceeds 0.6 V, Q3 turns on and terminates the output pulse. If only the  $80\ \Omega$  internal resistor is used (i.e., the  $I_{LIM}$  pin is connected directly to  $V_{IN}$ ), the maximum switch current will be 1.5 A. Figure 6 gives  $R_{LIM}$  values for lower current-limit values.

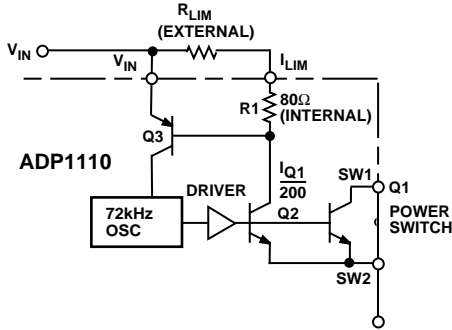

Figure 27. ADP1110 Current Limit Operation

The delay through the current limiting circuit is approximately 800 ns. If the switch ON time is reduced to less than 3  $\mu$ s, accuracy of the current trip-point is reduced. Attempting to program a switch ON time of 800 ns or less will produce spurious responses in the switch ON time; however, the ADP1110 will still provide a properly-regulated output voltage.

## PROGRAMMING THE GAIN BLOCK

The gain block of the ADP1110 can be used as a low-battery detector, error amplifier or linear post regulator. The gain block consists of an op amp with PNP inputs and an open-collector NPN output. The inverting input is internally connected to the ADP1110's 220 mV reference, while the noninverting input is available at the SET pin. The NPN output transistor will sink about 300  $\mu$ A.

Figure 28 shows the gain block configured as a low-battery monitor. Resistors R1 and R2 should be set to high values to reduce quiescent current, but not so high that bias current in the SET input causes large errors. A value of 33 k $\Omega$  for R2 is a good compromise. The value for R1 is then calculated from the formula:

$$R1 = \frac{V_{LOBATT} - 220\text{ mV}}{\frac{220\text{ mV}}{R2}}$$

where  $V_{LOBATT}$  is the desired low battery trip point. Since the gain block output is an open-collector NPN, a pull-up resistor should be connected to the positive logic power supply.

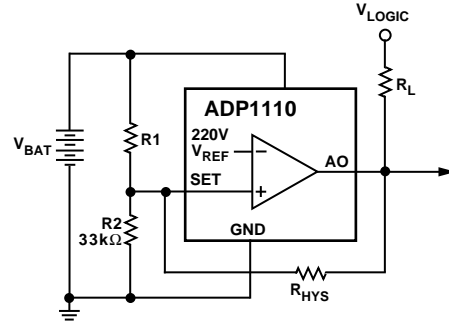

Figure 28. Setting the Low Battery Detector Trip Point

The circuit of Figure 28 may produce multiple pulses when approaching the trip point due to noise coupled into the SET input. To prevent multiple interrupts to the digital logic, hysteresis can be added to the circuit. Resistor  $R_{HYS}$ , with a value of 1 M $\Omega$  to 10 M $\Omega$ , provides the hysteresis. The addition of  $R_{HYS}$  will change the trip point slightly, so the new value for R1 will be:

$$R1 = \frac{V_{LOBATT} - 220\text{ mV}}{\frac{220\text{ mV}}{R2} - \left( \frac{V_L - 220\text{ mV}}{R_L + R_{HYS}} \right)}$$

where  $V_L$  is the logic power supply voltage,  $R_L$  is the pull-up resistor, and  $R_{HYS}$  creates the hysteresis.

The gain block can also be used as a control element to reduce output ripple. The ADP3000 is normally recommended for low-ripple applications, but its minimum input voltage is 2 V. The gain-block technique using the ADP1110 can be useful for step-up converters operating down to 1 V.

A step-up converter using this technique is shown in Figure 29. This configuration uses the gain block to sense the output voltage and control the comparator. The result is that the comparator hysteresis is reduced by the open loop gain of the gain block. Output ripple can be reduced to only a few millivolts with this technique, versus a typical value of 90 mV for a +5 V converter using just the comparator. For best results, a large output capacitor (1000  $\mu$ F or more) should be specified. This technique can also be used for step-down or inverting applications, but the ADP3000 is usually a more appropriate choice. See the ADP3000 data sheet for further details.

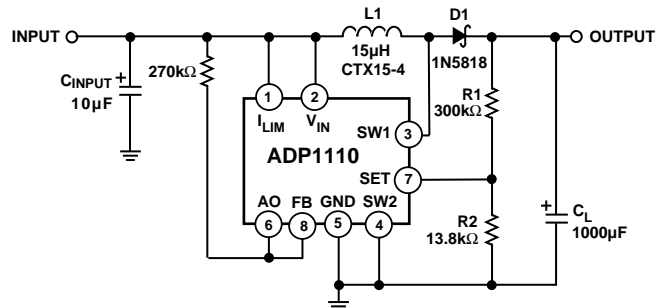

Figure 29. Using the Gain Block to Reduce Output Ripple

## APPLICATION CIRCUITS

### All-Surface-Mount, Single-Cell to 5 V Converter

This is a very simple, compact, low-part-count circuit that takes a single alkaline 1.5 V cell input and produces a 5 V output. The output current should be kept to 10 mA or less to conserve battery life.

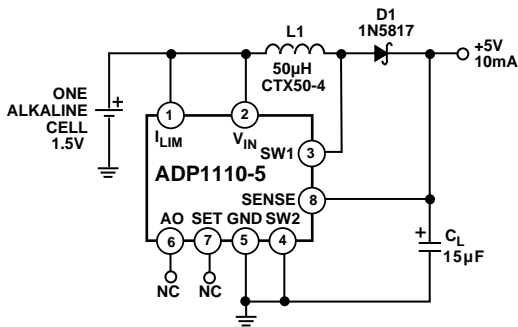

Figure 30. All-Surface-Mount, Single-Cell to 5 V Converter

### All-Surface-Mount, 3 V to 5 V Step-Up Converter

Similar to the previous circuit, this circuit takes a 3-volt input and provides a 5 V output at 40 mA. As in the single-cell version, the circuit is compact and uses only four external components.

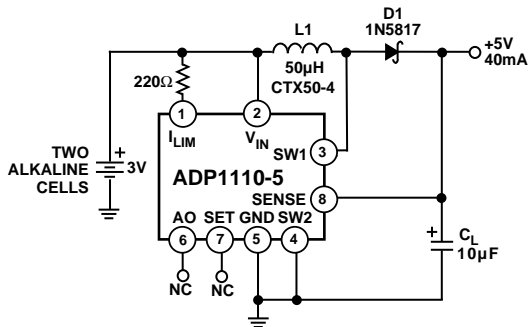

Figure 31. All-Surface-Mount, 3 V to 5 V Step-Up Converter

### All-Surface-Mount, 9 V to 5 V Step-Down Converter

Featuring the same low parts count of the step-up design, this circuit is the complement to the preceding one. The 220 Ω resistor programs the current limit to around 600 mA.

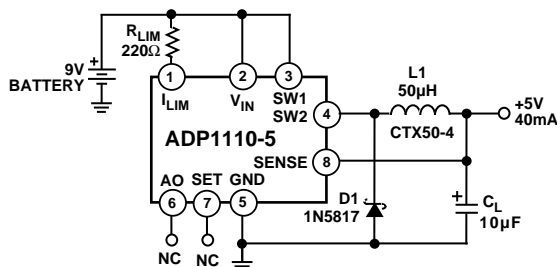

Figure 32. All-Surface-Mount, 9 V to 5 V Step-Down Converter

### 1.5 V to ±5 V Dual-Output Step-Up Converter

This circuit works from a single 1.5 V cell and provides simultaneous outputs of +5 V and -5 V. The accuracy of the negative output suffers slightly because of the extra diode drop of around 0.4 V.

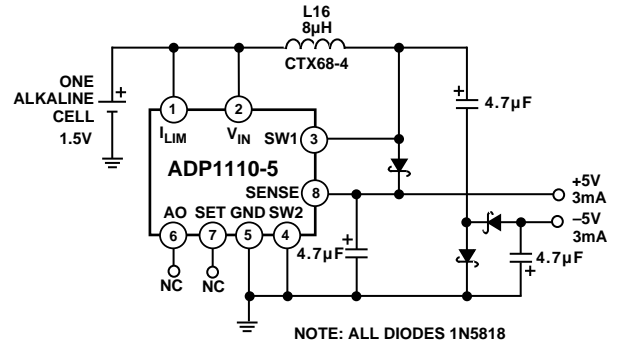

Figure 33. 1.5 V to ±5 V Dual-Output Step-Up Converter

### All-Surface-Mount Flash Memory VPP Generator

Figure 34 shows a circuit that can generate the programming voltage, VPP, to program flash memory. The key components are the MOSFET and the bipolar transistor. These two devices form a switch that, when ON, allows the ADP1110 to power-up and function as a step-up converter. The output is +12 V at 120 mA. When the MOSFET switch is OFF, the output of the circuit drops to just under +5 V thereby disabling the programming capability.

Care should be taken so there is no short-circuit-current limiting in the circuit in either operating mode.

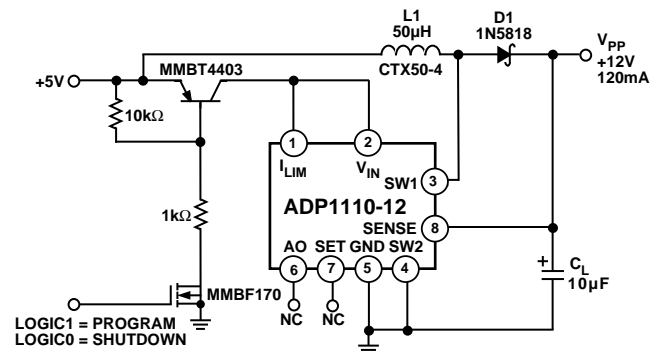

Figure 34. All Surface-Mount Flash Memory VPP Generator

# ADP1110

## 1.5 V to +5 V, +10 V Dual Output Step-Up Converter

The circuit of Figure 35 illustrates a way to get outputs of +10 V and +5 V from the same converter. The main 5 V output is derived from the feedback provided by the 487 k $\Omega$  and 11 k $\Omega$  resistors. Capacitor C1 should be a multilayer ceramic variety for best performance, but a good quality tantalum capacitor will also give good performance at lower cost.

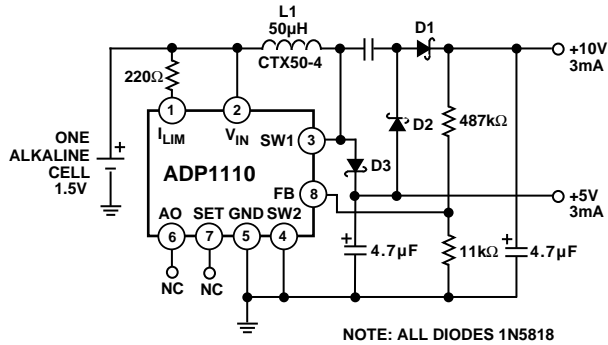

Figure 35. 1.5 V to +5 V, +10 V Dual Output Step-Up Converter

## 1.5 V-Powered Laser Diode Driver

Figure 36 shows a circuit suitable for driving many laser diodes that incorporate a photodiode to monitor the laser diode current, this circuit makes use of the gain block and current-limit functions to provide a feedback system based on the average laser diode current. This current must be controlled very closely or permanent damage to the laser diode is likely to be the result.

To ensure that the laser is operating at the proper power level, the actual optical power from the laser should be monitored with a calibrated photodiode or optical power meter. In addition, the actual diode current should also be monitored, and R1 can be adjusted to give the correct output power.

### NOTES

1. All inductors referenced are Coiltronics CTX-series except where noted.
2. If the source of power is more than an inch or so from the converter, the input to the converter should be bypassed with approximately 10  $\mu$ F of capacitance. This capacitor should be a good quality tantalum or aluminum electrolytic.

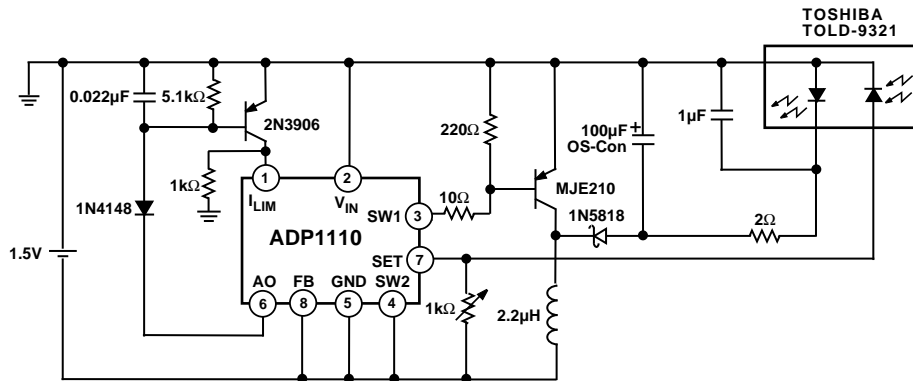
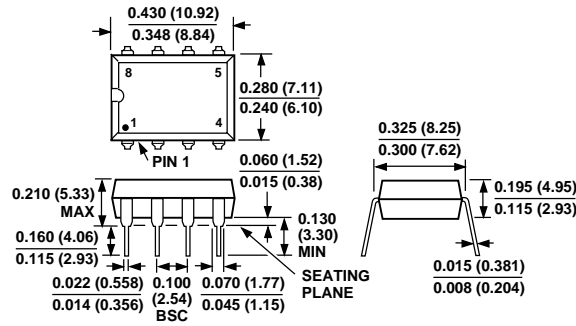

Figure 36. 1.5 V-Powered Laser Diode Driver

**OUTLINE DIMENSIONS**

Dimensions shown in inches and (mm).

**8-Lead Plastic DIP  
(N-8)**



**8-Lead SOIC  
(SO-8)**

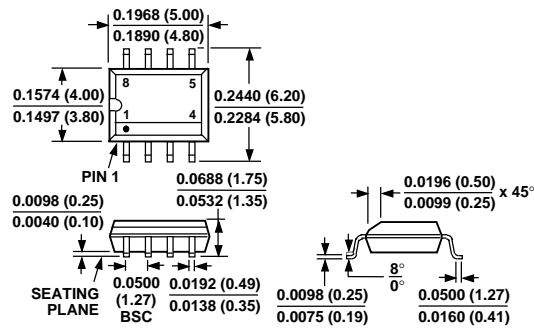





LittleDiode supplies new, hard to find or obsolete electronic components and semiconductors all over the world.

With over two million different components listed you are sure to find the part you need.

Feel free to visit us today at our online store:

[LittleDiode.com](http://LittleDiode.com)

Looking forward to providing you with the best possible service.