

# Am25LS2520

Octal D-Type Flip-Flop with Clear, Clock Enable and Three-State Control

## DISTINCTIVE CHARACTERISTICS

- Buffered common clock enable input
- Buffered common asynchronous clear input
- Three-state outputs
- 8-bit, high-speed parallel register with positive edge-triggered, D-type flip-flops
- Am25LS Family offers improved sink current, source current and noise margin

## GENERAL DESCRIPTION

The Am25LS2520 is an 8-bit register built using advanced Low-Power Schottky technology. The register consists of eight D-type flip-flops with a buffered common clock, a buffered common clock enable, a buffered asynchronous clear input, and three-state outputs.

When the clear input is LOW, the internal flip-flops of the register are reset to logic 0 (LOW), independent of all other inputs. When the clear input is HIGH, the register operates in the normal fashion.

When the three-state output enable ( $\overline{OE}$ ) input is LOW, the Y outputs are enabled and appear as normal TTL outputs.

When the output enable ( $\overline{OE}$ ) input is HIGH, the Y outputs are in the high impedance (three-state) condition. This does not affect the internal state of the flip-flop Q output.

The clock enable input ( $\overline{E}$ ) is used to selectively load data into the register. When the  $\overline{E}$  input is HIGH, the register will retain its current data. When the  $\overline{E}$  is LOW, new data is entered into the register on the LOW-to-HIGH transition of the clock input.

This device is packaged in a space-saving (0.4-inch row spacing) 22-pin package and in a 24-pin flatpack.

## BLOCK DIAGRAM

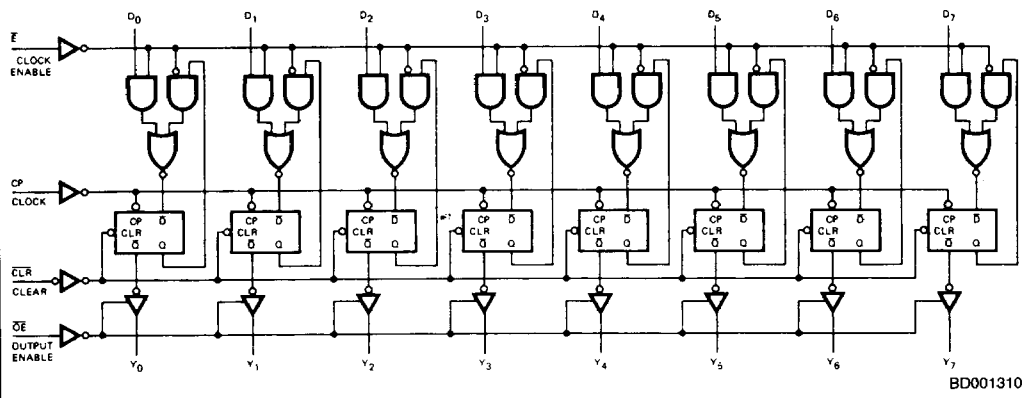

## RELATED PRODUCTS

Part No.	Description
Am25S18	Quad D Register
Am2920	Octal D-Type Flip-flop
Am2954/5	Octal D Registers

**CONNECTION DIAGRAM  
Top View**

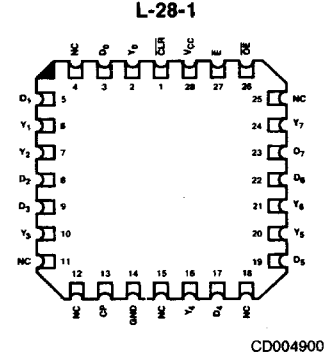
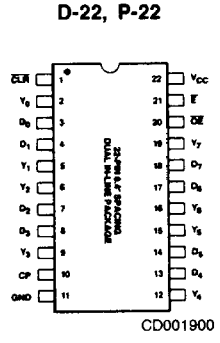
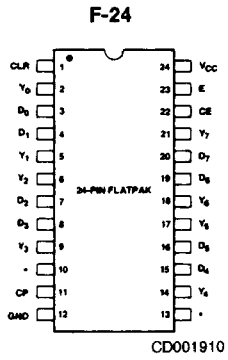

Note: Pin 1 is marked for orientation  
\*Reserved - do not use.

**LOGIC SYMBOL**

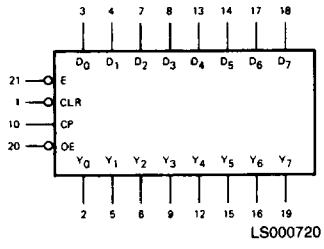

**METALLIZATION AND PAD LAYOUT**

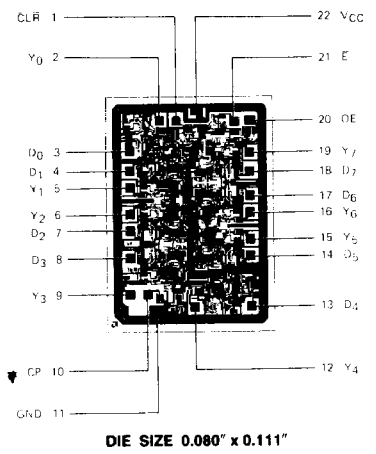

**ORDERING INFORMATION**

AMD products are available in several packages and operating ranges. The order number is formed by a combination of the following: Device number, speed option (if applicable), package type, operating range and screening option (if desired).

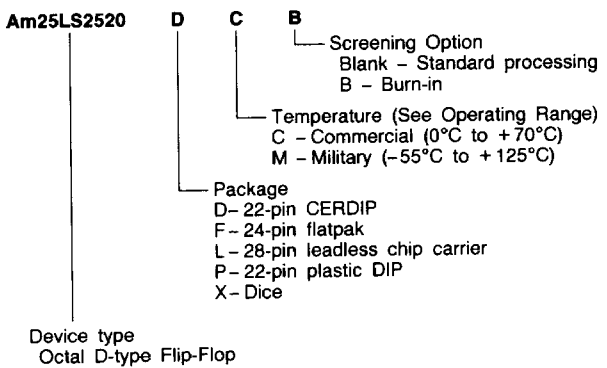

Valid Combinations	
Am25LS2520	PC DC, DM FM LC, LM XC, XM

**Valid Combinations**  
Consult the AMD sales office in your area to determine if a device is currently available in the combination you wish.

## PIN DESCRIPTION

Pin No.	Name	I/O	Description
	D <sub>i</sub>	I	The D flip-flop data inputs.
1	CLR	I	When the clear input is LOW, the Q <sub>i</sub> outputs are LOW, regardless of the other inputs. When the clear input is HIGH, data can be entered into the register.
11	CP	I	Clock Pulse for the Register; enters data into the register on the LOW-to-HIGH transition.
	Y <sub>i</sub>	O	The register three-state outputs.
21	E	I	Clock Enable. When the clock enable is LOW, data on the D <sub>i</sub> input is transferred to the Q <sub>i</sub> output on the LOW-to-HIGH clock transition. When the clock enable is HIGH, the Q <sub>i</sub> outputs do not change state, regardless of the data or clock input transitions.
20	OE	I	Output Control. When the OE input is HIGH, the Y <sub>i</sub> outputs are in the high impedance state. When the OE <sub>i</sub> input is LOW, the TRUE register data is present at the Y <sub>i</sub> outputs.

## FUNCTION TABLE

Function	Inputs					Internal	Outputs
	OE	CLR	E	D <sub>i</sub>	CP	Q <sub>i</sub>	Y <sub>i</sub>
Hi-Z	H	X	X	X	X	X	Z
Clear	H	L	X	X	X	L	Z
	L	L	X	X	X	L	L
Hold	H	H	H	X	X	NC	Z
	L	H	H	X	X	NC	NC
Load	H	H	L	L	↑	L	Z
	H	H	L	H	↑	H	Z
	L	H	L	L	↑	L	L
	L	H	L	H	↑	H	H

H = HIGH  
L = LOW  
NC = No change

↑ = LOW-to-HIGH Transition  
X = Don't Care  
Z = High-Impedance

APPLICATIONS

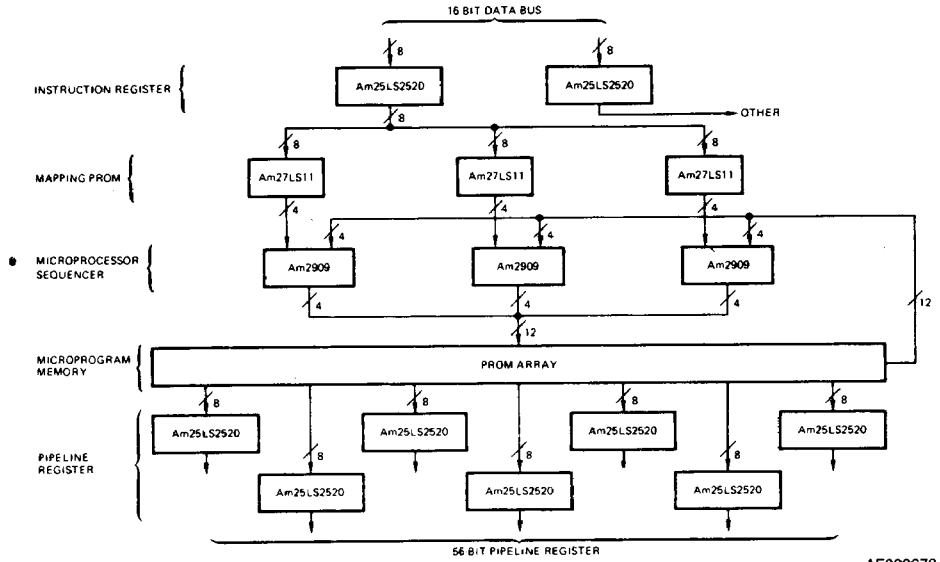

AF000670

A typical Computer Control Unit for a microprogrammed machine.

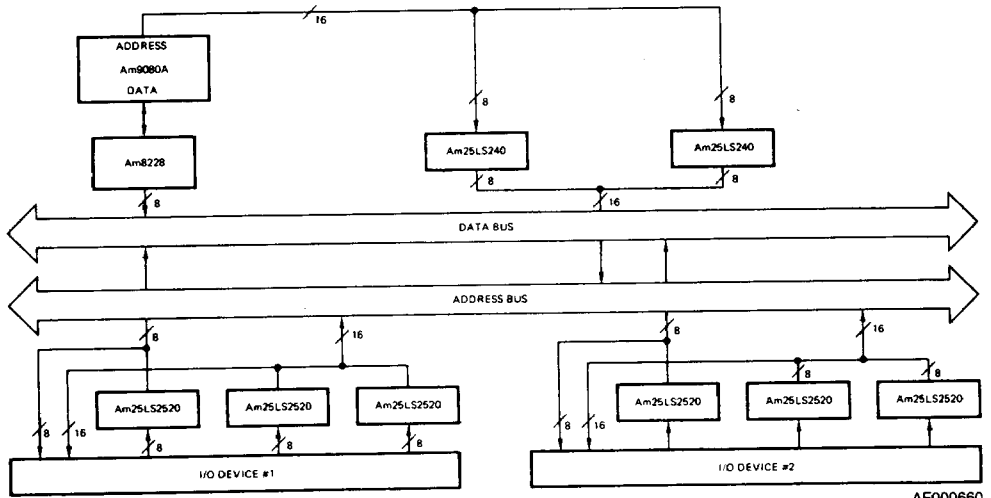

AF000660

The Am25LS2520 is a useful device in interfacing with the Am9080A system buses.

**ABSOLUTE MAXIMUM RATINGS**

Storage Temperature .....	-65°C to +150°C
(Ambient) Temperature Under Bias .....	-55°C to +125°C
Supply Voltage to Ground Potential	
Continuous .....	-0.5V to +7.0V
DC Voltage Applied to Outputs For	
High Output State .....	-0.5V to +V <sub>CC</sub> max
DC Input Voltage .....	-0.5V to +7.0V
DC Output Current, into Outputs .....	30mA
DC Input Current .....	-30mA to +5.0mA

Stresses above those listed under ABSOLUTE MAXIMUM RATINGS may cause permanent device failure. Functionality at or above these limits is not implied. Exposure to absolute maximum ratings for extended periods may affect device reliability.

**OPERATING RANGES**

Commercial (C) Devices	
Temperature .....	0°C to +70°C
Supply Voltage .....	+4.75V to +5.25V
Military (M) Devices	
Temperature .....	-55°C to +125°C
Supply Voltage .....	+4.5V to +5.5V

Operating ranges define those limits over which the functionality of the device is guaranteed.

**DC CHARACTERISTICS** over operating range unless otherwise specified

Parameters	Description	Test Conditions (Note 2)		Min	Typ (Note 1)	Max	Units
V <sub>OH</sub>	Output HIGH Voltage	V <sub>CC</sub> = MIN V <sub>IN</sub> = V <sub>IH</sub> or V <sub>IL</sub>	MIL, I <sub>OH</sub> = -1.0mA	2.4	3.4		Volts
			COM'L, I <sub>OH</sub> = -2.6mA	2.4	3.4		
V <sub>OL</sub>	Output LOW Voltage	V <sub>CC</sub> = MIN V <sub>IN</sub> = V <sub>IH</sub> or V <sub>IL</sub>	I <sub>OL</sub> = 4.0 mA			0.4	Volts
			I <sub>OL</sub> = 8.0mA			0.45	
V <sub>IH</sub>	Input HIGH Level	Guaranteed input logical HIGH voltage for all inputs		2.0			Volts
V <sub>IL</sub>	Input LOW Level	Guaranteed input logical LOW voltage for all inputs.		MIL		0.7	Volts
				COM'L		0.8	
V <sub>I</sub>	Input Clamp Voltage	V <sub>CC</sub> = MIN, I <sub>IN</sub> = -18mA				-1.5	Volts
I <sub>IL</sub>	Input LOW Current	V <sub>CC</sub> = MAX, V <sub>IN</sub> = 0.4V				-0.36	mA
I <sub>IH</sub>	Input HIGH Current	V <sub>CC</sub> = MAX, V <sub>IN</sub> = 2.7V				20	μA
I <sub>I</sub>	Input HIGH Current	V <sub>CC</sub> = MAX, V <sub>IN</sub> = 7.0V				0.1	mA
I <sub>O</sub>	Off-State (High-Impedance) Output Current	V <sub>CC</sub> = MAX	V <sub>O</sub> = 0.4V			-20	μA
			V <sub>O</sub> = 2.4V			20	
I <sub>SC</sub>	Output Short Circuit Current (Note 3)	V <sub>CC</sub> = MAX		-15		-85	mA
I <sub>CC</sub>	Power Supply Current (Note 4)	V <sub>CC</sub> = MAX			24	37	mA

- Notes: 1. Typical limits are at V<sub>CC</sub> = 5.0V, 25°C ambient and maximum loading.  
 2. For conditions shown as MIN or MAX, use the appropriate value specified under Operating Ranges for the applicable device type.  
 3. Not more than one output should be shorted at a time. Duration of the short circuit test should not exceed one second.  
 4. All outputs open,  $\bar{E}$  = GND, Di inputs = CLR =  $\bar{OE}$  = 4.5V. Apply momentary ground, then 4.5V to clock input.

**SWITCHING CHARACTERISTICS** ( $T_A = +25^\circ\text{C}$ ,  $V_{CC} = 5.0\text{V}$ )

Parameters	Description	Test Conditions	Min	Typ	Max	Units	
$t_{PLH}$	Clock to $Y_i$ ( $\overline{OE}$ LOW)	$C_L = 15\text{pF}$ $R_L = 2.0\text{k}\Omega$		18	27	ns	
$t_{PHL}$				24	36		
$t_{PHL}$	Clear to Y			22	35	ns	
$t_s$	Data ( $D_i$ )			10	3	ns	
$t_h$	Data ( $D_i$ )			10	3	ns	
$t_s$	Enable ( $\overline{E}$ )		Active		15	10	ns
			Inactive		20	12	
$t_h$	Enable ( $\overline{E}$ )			0	0	ns	
$t_s$	Clear Recovery (In-Active) to Clock			11	7	ns	
$t_w$	Clock		HIGH		20	14	ns
			LOW		25	13	
$t_{pw}$	Clear			20	13	ns	
$t_{ZH}$	$\overline{OE}$ to $Y_i$				9	13	ns
$t_{ZL}$					14	21	
$t_{HZ}$	$\overline{OE}$ to $Y_i$		$C_L = 5.0\text{pF}$ $R_L = 2.0\text{k}\Omega$		20	30	ns
$t_{LZ}$				24	36		
$f_{max}$	Maximum Clock Frequency (Note 1)				40		MHz

Note 1. Per industry convention,  $f_{max}$  is the worst case value of the maximum device operating frequency with no constraints on  $t_r$ ,  $t_f$ , pulse width or duty cycle.

**SWITCHING CHARACTERISTICS** over operating range unless otherwise specified\*

Parameters	Description	Test Conditions	COMMERCIAL		MILITARY		Units	
			Am25LS2520		Am25LS2520			
			Min	Max	Min	Max		
$t_{PLH}$	Clock to $Y_i$ ( $\overline{OE}$ LOW)	$C_L = 50\text{pF}$ $R_L = 2.0\text{k}\Omega$		33		39	ns	
$t_{PHL}$				45		54		
$t_{PHL}$	Clear to Y			43		51	ns	
$t_s$	Data ( $D_i$ )			12		15	ns	
$t_h$	Data ( $D_i$ )			12		15	ns	
$t_s$	Enable ( $\overline{E}$ )		Active		17		20	ns
			Inactive		20		23	
$t_h$	Enable ( $\overline{E}$ )			0		0	ns	
$t_s$	Clear Recovery (In-Active) to Clock			13		15	ns	
$t_{pw}$	Clock		HIGH		25		30	ns
			LOW		30		35	
$t_{pw}$	Clear			22		25	ns	
$t_{ZH}$	$\overline{OE}$ to $Y_i$				19		25	ns
$t_{ZL}$					30		39	
$t_{HZ}$	$\overline{OE}$ to $Y_i$		$C_L = 5.0\text{pF}$ $R_L = 2.0\text{k}\Omega$		35		40	ns
$t_{LZ}$				39		42		
$f_{max}$	Maximum Clock Frequency (Note 1)			25		20		MHz

\*AC performance over the operating temperature range is guaranteed by testing defined in Group A, Subgroup 9.

### Am25LS2520 LOW-POWER SCHOTTKY INPUT/OUTPUT CURRENT INTERFACE CONDITIONS

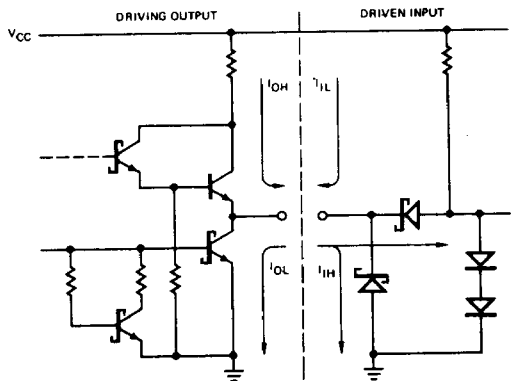

IC000090

Note: Actual current flow direction shown.

This datasheet has been downloaded from:

[www.DatasheetCatalog.com](http://www.DatasheetCatalog.com)

Datasheets for electronic components.



LittleDiode supplies new, hard to find or obsolete electronic components and semiconductors all over the world.

With over two million different components listed you are sure to find the part you need.

Feel free to visit us today at our online store:

[LittleDiode.com](http://LittleDiode.com)

Looking forward to providing you with the best possible service.