

FM / TV front end

BA4424N

The BA4424N is a monolithic IC designed for FM front end use. It consists of an RF amplifier circuit, mixer circuit, local oscillation circuit, IF buffer amplifier, and a variable capacitor-diode for AFC.

●Features

- 1) An RF amplifier, mixer, local oscillator, IF buffer amplifier, and AFC diode are included on-chip.
- 2) Reception of VHF terrestrial TV channels is possible.
- 3) Uses a double balance mixer to improve intermodulation characteristics.
- 4) Includes a clamp diode in the mixer output.
- 5) Local oscillation buffer on-chip for improved response to strong input.
- 6) The output impedance of the IF buffer amplifier is matched with the ceramic filter impedance at 330Ω.
- 7) A resistive load can also be used for the mixer output.
- 8) Mixer input coupling capacitor included on-chip.
- 9) Includes a feedback capacitor for the local oscillation circuit.
- 10) Compact 9-pin SIP package. Pins arranged for convenient mounting.

●Absolute maximum ratings (Ta = 25°C)

Parameter	Symbol	Limits	Unit
Power supply voltage	V _{CC}	7.0	V
Power dissipation*	P _d	500	mW
Operating temperature	T _{opr}	-25~+75	°C
Storage temperature	T _{stg}	-55~+125	°C
AFC applied voltage	V _r	5.0	V

* Reduced by 5.0 mW each increase in Ta of 1°C over 25°C.

●Recommended operating conditions (Ta = 25°C)

Parameter	Symbol	Min.	Typ.	Max.	Unit
Power supply voltage	V _{CC}	1.6	4.0	6.0	V

●Block diagram

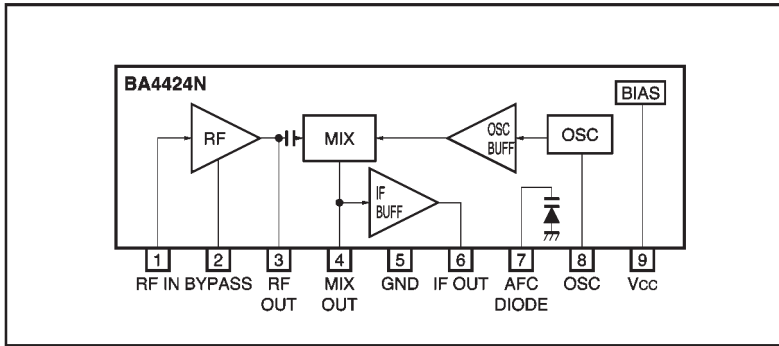

●Electrical characteristics

DC characteristics (unless otherwise noted, $T_a = 25^\circ\text{C}$, $V_{CC} = 4\text{V}$, no input)

Pin No.	Symbol	Typ.	Unit
1	V_1	0.5	V
2	V_2	1.2	V
3	V_3	3.8	V
4	V_4	4.0	V
5	V_5	0	V
6	V_6	3.3	V
7	V_7	0	V
8	V_8	3.9	V
9	V_9	4.0	V

AC characteristics (unless otherwise noted, $T_a = 25^\circ\text{C}$ and $V_{CC} = 4\text{V}$)

Parameter	Symbol	Min.	Typ.	Max.	Unit	Conditions
Quiescent current	I_q	2.6	4.5	7.2	mA	—
Output saturation voltage	V_o	30	50	72	mV _{rms}	$f_d=98\text{MHz}$ 100dB μV
Local oscillation voltage	V_{OSC}	200	400	630	mV _{rms}	$f_{OSC}=108.7\text{MHz}$ $R_S=0\Omega$
Conversion gain	G_{VC}	31	36	42	dB	$f_d=98\text{MHz}$, 55dB μV
Local oscillation stop voltage	V_{stop}	—	0.9	1.2	V _{DC}	$R_S=0\Omega$
AFC diode capacitance	C_{AFC}	—	13	—	pF	$V_r=2V_{DC}$

● Measurement circuit

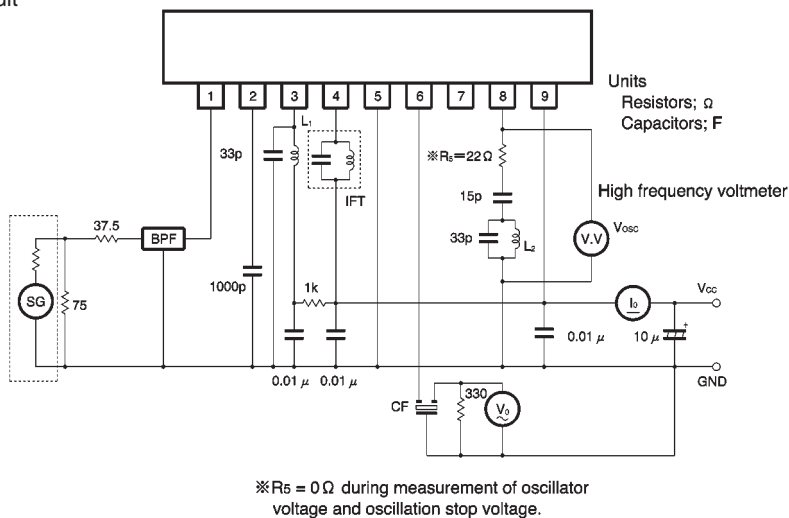

Fig. 1

● Pin connections

- | | | | |
|--------------------------------|--------------------------------------|---------------------------|---|
| ① FM ANT input pin | : Connect to BPF $Z_{IN} = 75\Omega$ | ⑥ IF amplifier output pin | : $Z_{OUT} = 330\Omega$ |
| ② RF amplifier bypass pin | : Connect to bypass capacitor | ⑦ AFC diode pin | : Cathode pin (anode pin is connected internally to ground) |
| ③ RF amplifier output load pin | : Connect to RF tuning circuit | ⑧ OSC pin | : Connect to resonating circuit |
| ④ MIX output pin | : IFT or resistor load | ⑨ V_{CC} pin | : IC voltage supply pin |
| ⑤ GND pin | : IC ground pin | | |

● Circuit operation

(1) RF amplifier circuit

The RF amplifier consists of a common base transistor. A band pass filter (BPF) is used in the ANT circuit, and as the RF amplifier is base-grounded, a BPF with an output impedance of 75Ω should be used. If a BPF without DC cutoff is used, a coupling capacitor will be necessary. An LC tuning circuit is connected to form the output load of the RF amplifier. A coil with tap or coil with secondary winding can be used to reduce spurious ratios such as image ratios. A coupling capacitor for the mixer circuit is included on-chip. The bypass capacitor for the RF amplifier should have good high frequency characteristics, and it should be connected to the input BPF ground connection as close as possible to Pin 5 (GND), such that the connection pattern absolutely does not allow supply current to flow from Pin 5.

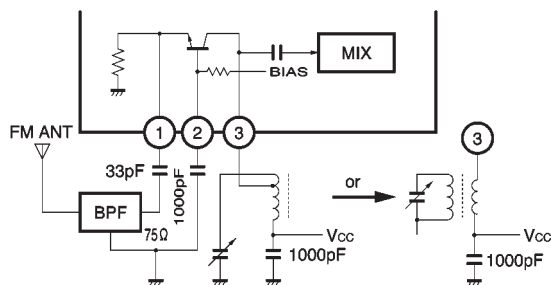

Fig.2

(2) Mixer circuit

The mixer circuit is a double balance type with minimal OSC leakage and little spurious interference. The mixer output includes a diode limiter for improved response to strong input signals.

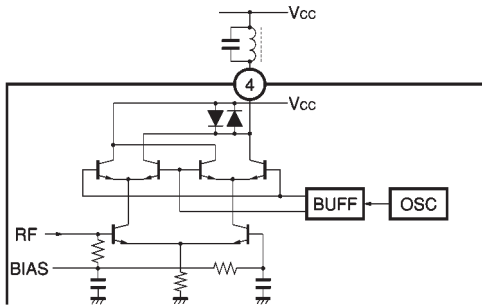

Fig. 3

In addition to an IFT, a resistive load can also be used for the mixer output load. However, take care in this case as the gain will fall.

(3) Local oscillation circuit

The local oscillation circuit is a Colpitts circuit with grounded collector. The capacitor between the base and emitter and the capacitor between the collector and emitter which form the oscillation circuit are included on the IC. A buffer has been added for input to the mixer circuit to protect the circuit when strong input is present. R_s is to prevent spurious radiation. Take care when setting the value.

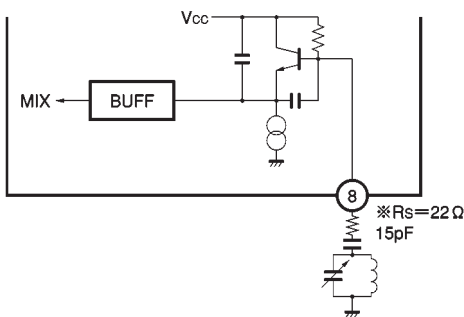

Fig. 4

(4) IF buffer amplifier circuit

The IF buffer amplifier consists of an emitter-follower amplifier circuit. The output impedance is set in the IC to 330Ω , and it can be directly connected to a ceramic filter.

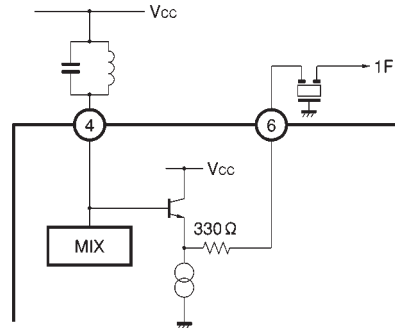

Fig. 5

(5) Variable capacitor-diode for AFC

A variable capacitor-diode is included in the IC for AFC. Utilize the FM detection output as AFC signal. The anode is connected to ground.

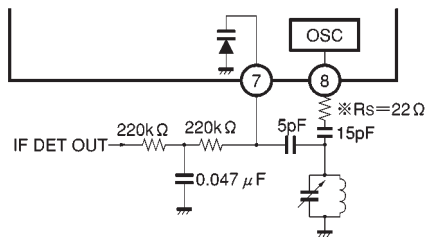

Fig. 6

● Operation notes

(1) Application circuit

The example application circuit is the one which we recommend, however, when using it, verify characteristics carefully.

If external circuit values are changed, set them with sufficient margin to allow for deviations of both the Rohm IC and external components in the quiescent and transient characteristics. Also, please note that we have not completely verified any possible patent issues which the application circuit may involve.

(2) Operating power supply voltage range

As long as the operating power supply voltage range is not exceeded, the circuit functions are guaranteed within the ambient operating temperature. Although we cannot guarantee that the electrical characteristic values rated under the rating conditions will be obtained, there will be no abrupt changes in the characteristics within this range.

(3) RF amplifier

A band pass filter (BPF) is used in the ANT circuit, and as the RF amplifier is base-grounded, a BPF with an output impedance of 75Ω must be used. If a BPF without DC cutoff is used, a coupling capacitor will be necessary. Connect the bypass capacitor to the ground connection of the input BPF. The pattern connecting these should be such that supply current will absolutely not flow from Pin 5 (the ground line should be laid in the same fashion as shown in the measurement circuit schematic).

(4) Mixer load

In addition to an IFT, a resistive load can also be used for the mixer output load. However, take care in this case as the gain and intermodulation characteristics will be affected.

(5) Local oscillation circuit

To reduce spurious radiation, the oscillation level at Pin 8 (OSC) can be adjusted. This is done by adding a resistor (several Ω to several tens of Ω) between Pin 8 and the tank circuit. However, when setting the value, take care regarding the oscillation margin as related to the tank circuit Q damp.

(6) IF buffer amplifier

If the buffer amplifier pin is connected to another circuit to use the buffer amplifier pin's voltage, take care that a reverse voltage never appears at the pin.

(7) Power supply RC filter

Do not insert a resistor between the V_{CC} pin (Pin 9) and the MIX OUT pins (Pins 3 and 4), as a resistor inserted in the power supply line will decrease sensitivity due to the drop in the voltage. Regarding the resistor between Pin 9 and the RFout pin (Pin 3), set the value so that the voltage at Pin 3 is not lower than the voltage at Pin 2.

●Electrical characteristic curves

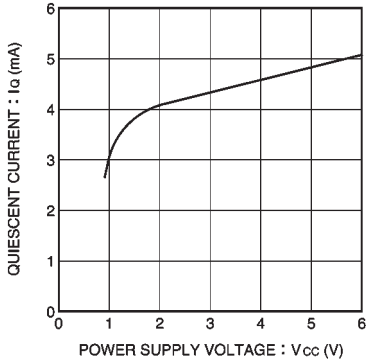

Fig. 7 Quiescent current vs. power supply voltage

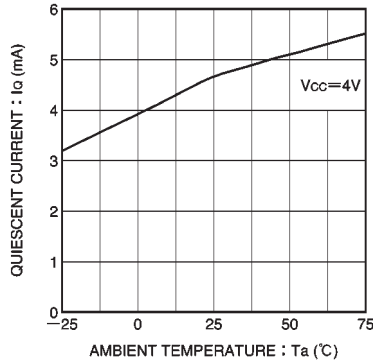

Fig. 8 Quiescent current vs. ambient temperature

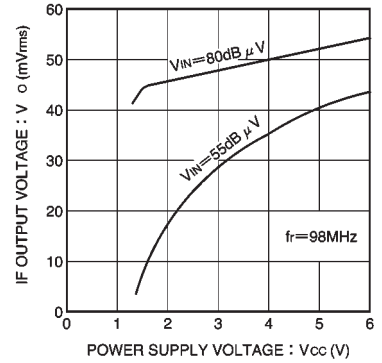

Fig. 9 IF output voltage vs. power supply voltage

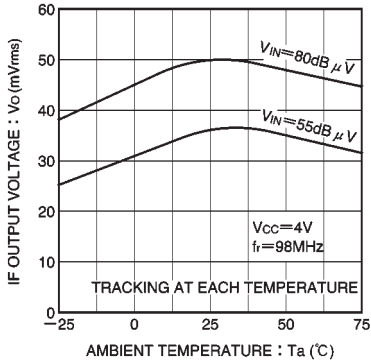

Fig. 10 IF output voltage vs. ambient temperature

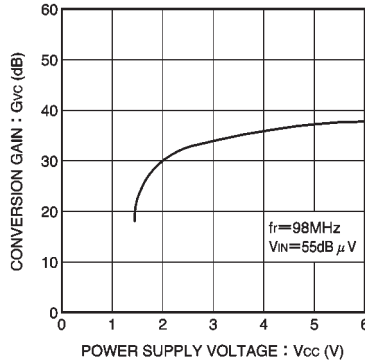

Fig. 11 Conversion gain vs. power supply voltage

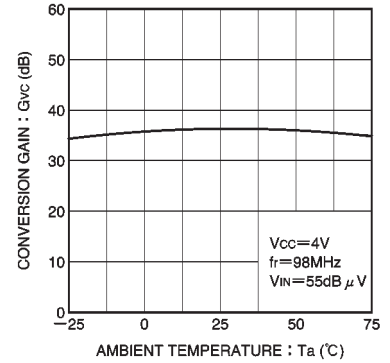

Fig. 12 Conversion gain vs. ambient temperature

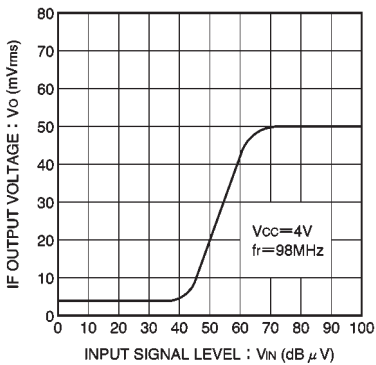

Fig. 13 IF output voltage vs. input signal level

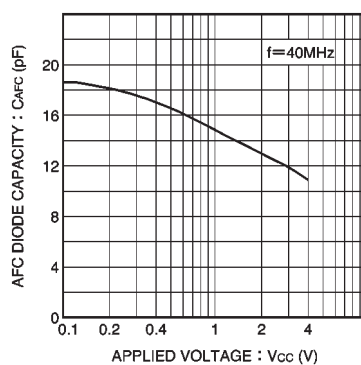

Fig. 14 AFC diode capacity vs. applied voltage

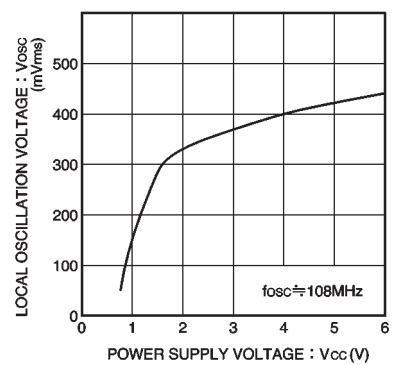

Fig. 15 Local oscillation voltage vs. power supply voltage

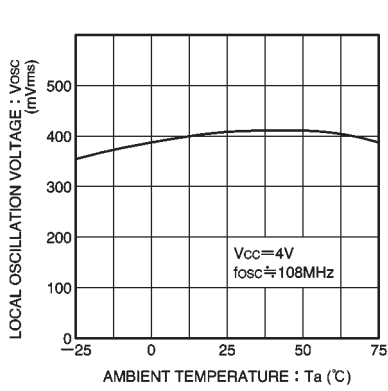

Fig. 16 Local oscillation voltage vs. ambient temperature

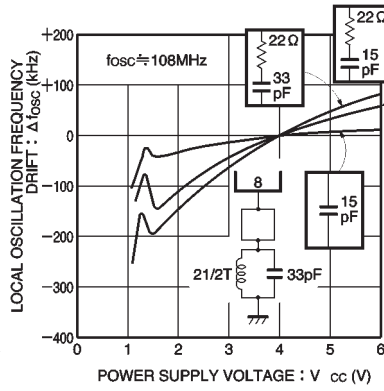

Fig. 17 Local oscillation frequency vs. power supply voltage

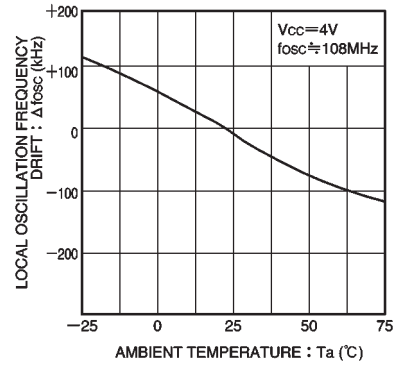
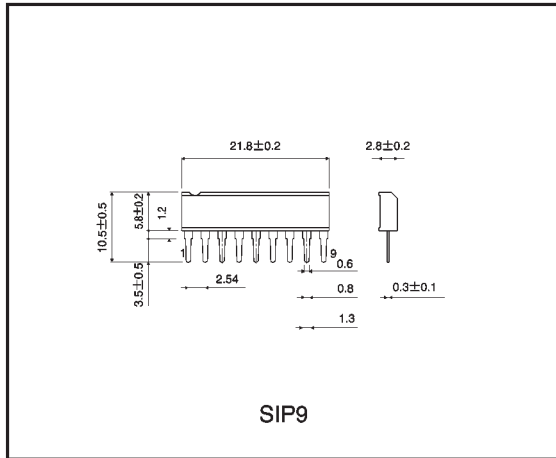

Fig. 18 Local oscillation frequency vs. ambient temperature

● External dimensions (Units: mm)



This datasheet has been downloaded from:

www.DatasheetCatalog.com

Datasheets for electronic components.



LittleDiode supplies new, hard to find or obsolete electronic components and semiconductors all over the world.

With over two million different components listed you are sure to find the part you need.

Feel free to visit us today at our online store:

LittleDiode.com

Looking forward to providing you with the best possible service.