

HD14160B, HD14161B HD14162B, HD14163B

- HD14160B.....Decade Counter with Asynchronous Clear
- HD14161B.....4-bit Binary Counter with Asynchronous Clear
- HD14162B.....Decade Counter with Synchronous Clear
- HD14163B.....4-bit Binary Counter with Synchronous Clear

The HD14160B to HD14163B are synchronous programmable counters and functionally equivalent to the 74160 to 74163 TTL counters. Two are synchronous programmable decade counters with asynchronous and synchronous clear inputs respectively (HD14160B, HD14162B). The other two are synchronous programmable 4-bit binary counters with the asynchronous and synchronous clear respectively (HD14161B, HD14163B).

■ FEATURES

- Internal Look-Ahead for Fast Counting
- Carry Output for N-bit Cascading
- Synchronously Programmable
- Synchronous Counting
- Load Control Line
- Synchronous or Asynchronous Clear Positive Edge Clocked

■ PIN ARRANGEMENT

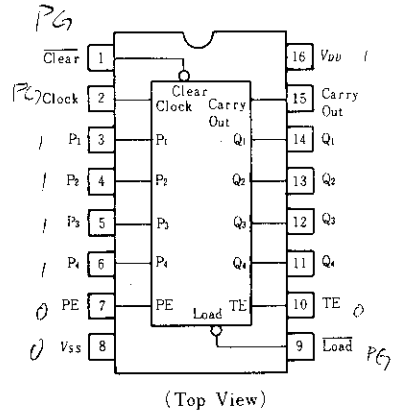

■ LOGIC DIAGRAM

● HD14160B, HD14162B

(Clear is synchronous for HD14162B)

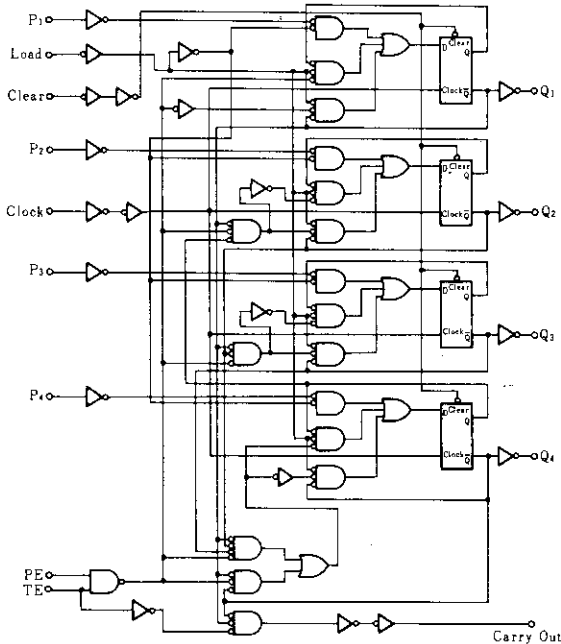

● HD14161B, HD14163B

(Clear is Synchronous for HD14163B)

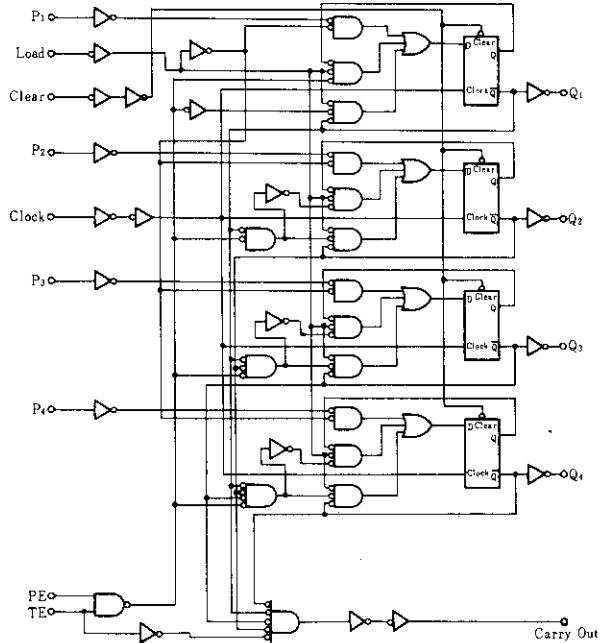

ELECTRICAL CHARACTERISTICS

Characteristic	Symbol	Test Conditions	-40°C		25°C			85°C		Unit	
			min	max	min	typ	max	min	max		
Output Voltage	V_{OL}	V_{DD} (V)									
		5.0		0.05	—	0	0.05	—	0.05	V	
		10	$V_{in}=V_{DD}$ or 0	—	0.05	—	0	0.05	—		0.05
	15		—	0.05	—	0	0.05	—	0.05		
	V_{OH}	5.0		4.95	—	4.95	5.0	—	4.95	V	
		10	$V_{in}=0$ or V_{DD}	9.95	—	9.95	10	—	9.95		
15			14.95	—	14.95	15	—	14.95			
Input Voltage	V_{IL}	5.0	$V_{out}=4.5$ or 0.5V	—	1.5	—	2.25	1.5	—	1.5	V
		10	$V_{out}=9.0$ or 1.0V	—	3.0	—	4.50	3.0	—	3.0	
		15	$V_{out}=13.5$ or 1.5V	—	4.0	—	6.75	4.0	—	4.0	
	V_{IH}	5.0	$V_{out}=0.5$ or 4.5V	3.5	—	3.5	2.75	—	3.5	—	V
		10	$V_{out}=1.0$ or 9.0V	7.0	—	7.0	5.50	—	7.0	—	
		15	$V_{out}=1.5$ or 13.5V	11.0	—	11.0	8.25	—	11.0	—	
Output Drive Current	I_{OH}	5.0	$V_{OH}=2.5$ V	-2.5	—	-2.1	-4.2	—	-1.7	—	mA
		5.0	$V_{OH}=4.6$ V	-0.52	—	-0.44	-0.88	—	-0.36	—	
		10	$V_{OH}=9.5$ V	-1.3	—	-1.1	-2.25	—	-0.9	—	
		15	$V_{OH}=13.5$ V	-3.6	—	-3.0	-8.8	—	-2.4	—	
	I_{OL}	5.0	$V_{OL}=0.4$ V	0.52	—	0.44	0.88	—	0.36	—	mA
		10	$V_{OL}=0.5$ V	1.3	—	1.1	2.25	—	0.9	—	
15		$V_{OL}=1.5$ V	3.6	—	3.0	8.8	—	2.4	—		
Input Current	I_{in}	15		—	± 0.3	—	± 0.0001	± 0.3	—	± 1.0	μA
Input Capacitance	C_{in}	—	$V_{in}=0$	—	—	—	5.0	7.5	—	—	pF
Quiescent Current	I_{DD}	5.0	Zero Signal, per Package	—	20	—	0.005	20	—	150	μA
		10		—	40	—	0.010	40	—	300	
		15		—	80	—	0.015	80	—	600	
Total Supply Current*	I_T	5.0	Dynamic + I_{DD} ,	—	—	—	0.56	—	—	—	μA
		10	per Gate, $C_L=50$ pF	—	—	—	1.1	—	—	—	
		15	$f=1$ kHz	—	—	—	1.9	—	—	—	

* To calculate total supply current at frequency other than 1kHz.
 @ $V_{DD}=5.0$ V $I_T=(0.56\mu A/kHz)f+I_{DD}$, @ $V_{DD}=10$ V $I_T=(1.1\mu A/kHz)f+I_{DD}$, @ $V_{DD}=15$ V $I_T=(1.9\mu A/kHz)f+I_{DD}$

DYNAMIC SIGNAL WAVEFORMS

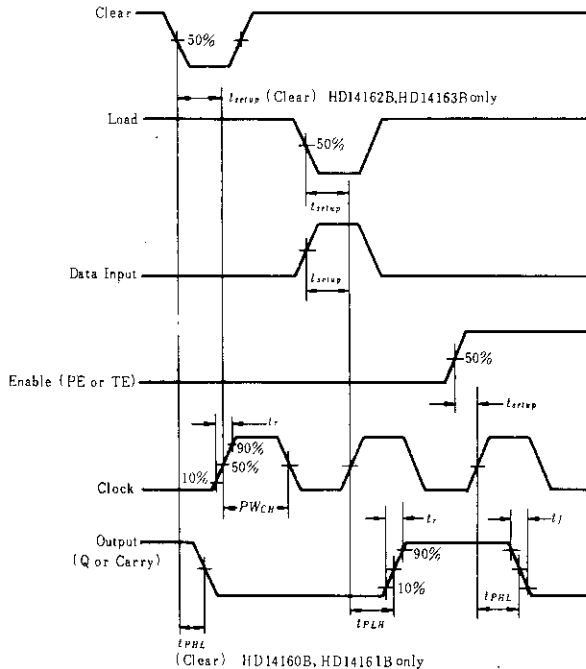

■ SWITCHING CHARACTERISTICS ($C_L=50\text{pF}$, $T_a=25^\circ\text{C}$)

Characteristic		Symbol	V_{DD} (V)	min	typ	max	Unit	
Output Rise Time		t_r	5.0	—	100	200	ns	
			10	—	50	100		
			15	—	40	80		
Output Fall Time		t_f	5.0	—	100	200	ns	
			10	—	50	100		
			15	—	40	80		
Propagation Delay Time	Clock to Q		5.0	—	350	700	ns	
			10	—	150	300		
			15	—	100	200		
	Clock to Carry Out	t_{PLH}	5.0	—	440	880		
			10	—	185	370		
			15	—	125	250		
	TE to Carry Out	t_{PHL}	5.0	—	300	600		
			10	—	130	260		
			15	—	90	180		
	Clear to Q (HD14160B, HD14161B only)			5.0	—	155		310
				10	—	55		110
				15	—	35		70
Setup Time	Data to Clock		5.0	320	160	—	ns	
			10	130	65	—		
			15	90	45	—		
	Load to Clock	t_{setup}	5.0	600	300	—		
			10	260	130	—		
			15	180	90	—		
	Enable to Clock (PE or TE)		5.0	420	210	—		
			10	170	85	—		
			15	120	60	—		
	Clear to Clock (HD14162B, HD14163B only)		5.0	310	155	—		
			10	110	55	—		
			15	70	35	—		
Clock Pulse Width		PW_{CH}	5.0	250	125	—	ns	
			10	100	50	—		
			15	70	35	—		
Clock Rise Time		t_r	5.0	—	—	15	μs	
			10	—	—	15		
			15	—	—	15		
Clock Frequency		PRF	5.0	—	2.0	1.0	MHz	
			10	—	5.0	2.5		
			15	—	8.0	4.0		

■ TIMING DIAGRAM

● HD14160B, HD14162B

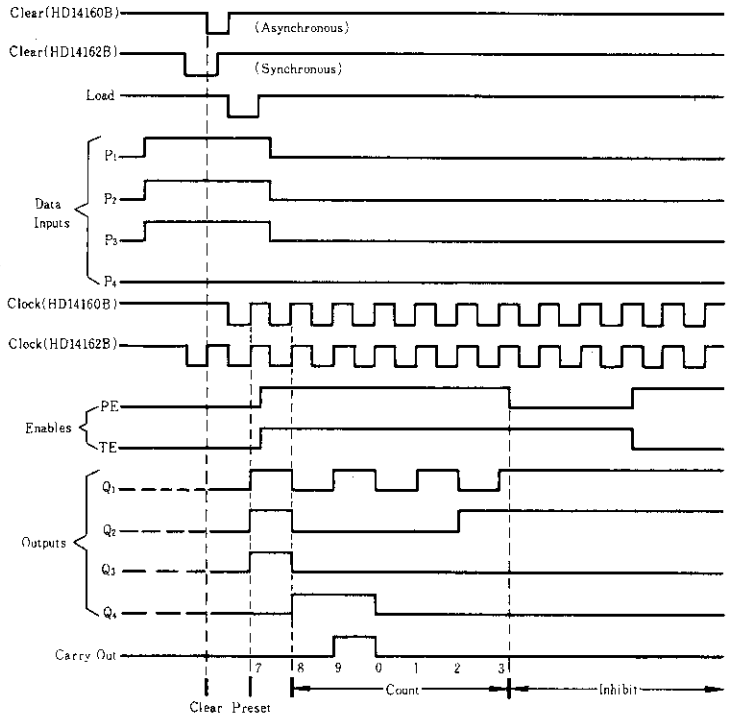

Sequence illustrated in waveforms :

1. Clear outputs to zero.
2. Preset to BCD seven.
3. Count to eight, nine, zero, one, two, and three.
4. Inhibit

● HD14161B, HD14163B

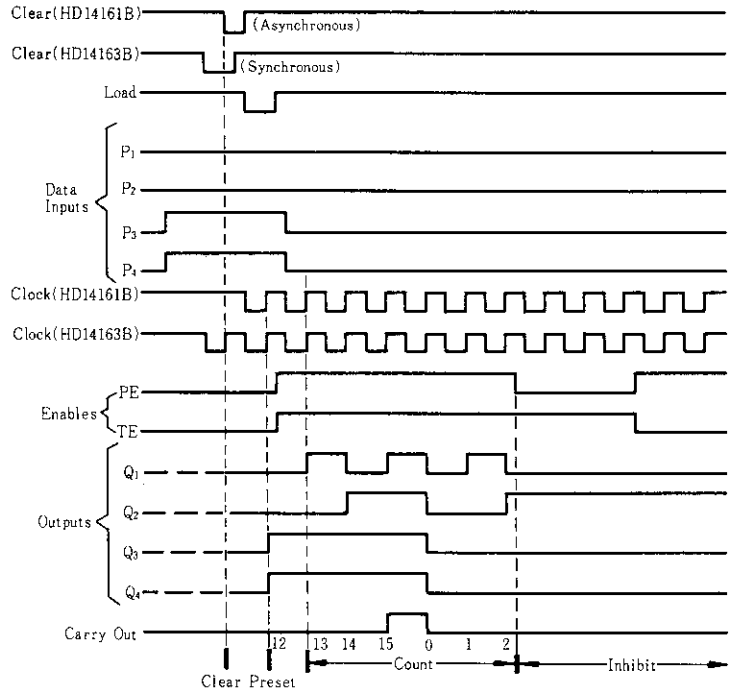

Sequence illustrated in waveforms :

1. Clear outputs to zero.
2. Preset to binary twelve.
3. Count to thirteen, fourteen, fifteen, zero, one, and two.
4. Inhibit

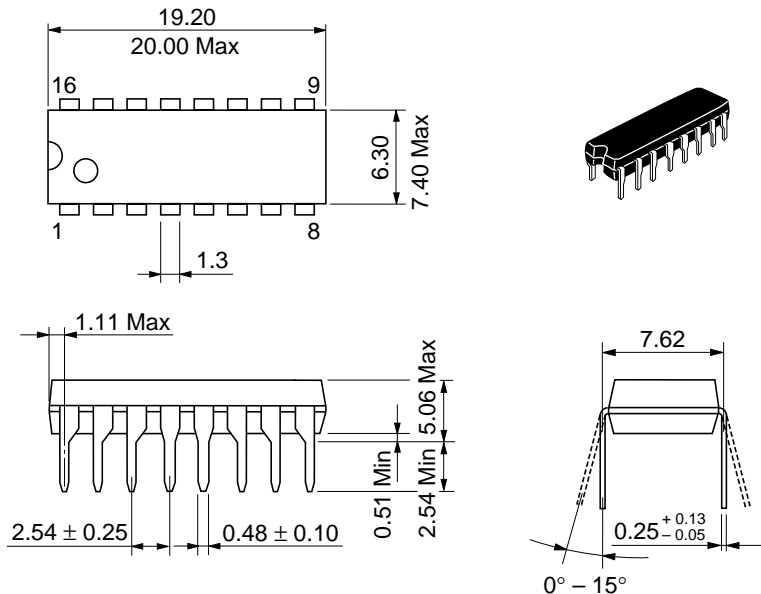

Hitachi Code	DP-16
JEDEC	Conforms
EIAJ	Conforms
Weight (reference value)	1.07 g

Cautions

1. Hitachi neither warrants nor grants licenses of any rights of Hitachi's or any third party's patent, copyright, trademark, or other intellectual property rights for information contained in this document. Hitachi bears no responsibility for problems that may arise with third party's rights, including intellectual property rights, in connection with use of the information contained in this document.
2. Products and product specifications may be subject to change without notice. Confirm that you have received the latest product standards or specifications before final design, purchase or use.
3. Hitachi makes every attempt to ensure that its products are of high quality and reliability. However, contact Hitachi's sales office before using the product in an application that demands especially high quality and reliability or where its failure or malfunction may directly threaten human life or cause risk of bodily injury, such as aerospace, aeronautics, nuclear power, combustion control, transportation, traffic, safety equipment or medical equipment for life support.
4. Design your application so that the product is used within the ranges guaranteed by Hitachi particularly for maximum rating, operating supply voltage range, heat radiation characteristics, installation conditions and other characteristics. Hitachi bears no responsibility for failure or damage when used beyond the guaranteed ranges. Even within the guaranteed ranges, consider normally foreseeable failure rates or failure modes in semiconductor devices and employ systemic measures such as fail-safes, so that the equipment incorporating Hitachi product does not cause bodily injury, fire or other consequential damage due to operation of the Hitachi product.
5. This product is not designed to be radiation resistant.
6. No one is permitted to reproduce or duplicate, in any form, the whole or part of this document without written approval from Hitachi.
7. Contact Hitachi's sales office for any questions regarding this document or Hitachi semiconductor products.

HITACHI

Hitachi, Ltd.

Semiconductor & Integrated Circuits.
Nippon Bldg., 2-6-2, Ohte-machi, Chiyoda-ku, Tokyo 100-0004, Japan
Tel: Tokyo (03) 3270-2111 Fax: (03) 3270-5109

URL North America : <http://semiconductor.hitachi.com/>
Europe : <http://www.hitachi-eu.com/hel/ecg>
Asia (Singapore) : <http://www.has.hitachi.com.sg/grp3/sicd/index.htm>
Asia (Taiwan) : http://www.hitachi.com.tw/E/Product/SICD_Frame.htm
Asia (HongKong) : <http://www.hitachi.com.hk/eng/bo/grp3/index.htm>
Japan : <http://www.hitachi.co.jp/Sicd/indx.htm>

For further information write to:

Hitachi Semiconductor
(America) Inc.
179 East Tasman Drive,
San Jose, CA 95134
Tel: <1> (408) 433-1990
Fax: <1> (408) 433-0223

Hitachi Europe GmbH
Electronic components Group
Dornacher Straße 3
D-85622 Feldkirchen, Munich
Germany
Tel: <49> (89) 9 9180-0
Fax: <49> (89) 9 29 30 00

Hitachi Europe Ltd.
Electronic Components Group.
Whitebrook Park
Lower Cookham Road
Maidenhead
Berkshire SL6 8YA, United Kingdom
Tel: <44> (1628) 585000
Fax: <44> (1628) 778322

Hitachi Asia Pte. Ltd.
16 Collyer Quay #20-00
Hitachi Tower
Singapore 049318
Tel: 535-2100
Fax: 535-1533

Hitachi Asia Ltd.
Taipei Branch Office
3F, Hung Kuo Building, No.167,
Tun-Hwa North Road, Taipei (105)
Tel: <886> (2) 2718-3666
Fax: <886> (2) 2718-8180

Hitachi Asia (Hong Kong) Ltd.
Group III (Electronic Components)
7/F., North Tower, World Finance Centre,
Harbour City, Canton Road, Tsim Sha Tsui,
Kowloon, Hong Kong
Tel: <852> (2) 735 9218
Fax: <852> (2) 730 0281
Telex: 40815 HITEC HX

Copyright ' Hitachi, Ltd., 1999. All rights reserved. Printed in Japan.

HITACHI



LittleDiode supplies new, hard to find or obsolete electronic components and semiconductors all over the world.

With over two million different components listed you are sure to find the part you need.

Feel free to visit us today at our online store:

LittleDiode.com

Looking forward to providing you with the best possible service.