

DM5490/DM7490A, DM7493A Decade and Binary Counters

General Description

Each of these monolithic counters contains four master-slave flip-flops and additional gating to provide a divide-by-two counter and a three-stage binary counter for which the count cycle length is divide-by-five for the 90A and divide-by-eight for the 93A.

All of these counters have a gated zero reset and the 90A also has gated set-to-nine inputs for use in BCD nine's complement applications.

To use their maximum count length (decade or four-bit binary), the B input is connected to the Q_A output. The input count pulses are applied to input A and the outputs are as

described in the appropriate truth table. A symmetrical divide-by-ten count can be obtained from the 90A counters by connecting the Q_D output to the A input and applying the input count to the B input which gives a divide-by-ten square wave at output Q_A .

Features

- Typical power dissipation
 - 90A 145 mW
 - 93A 130 mW
- Count frequency 42 MHz

Connection Diagrams

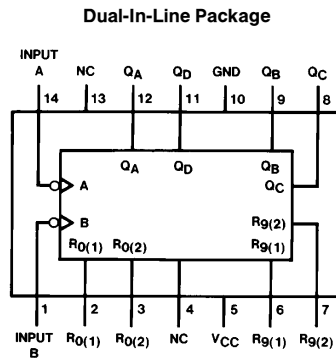

TL/F/6533-1

Order Number DM5490J, DM5490W or DM7490AN
See NS Package Number J14A, N14A or W14B

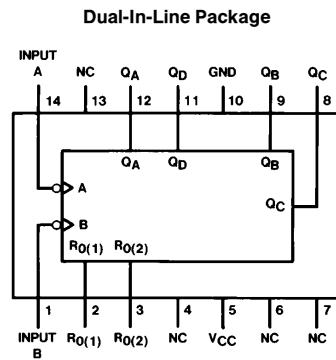

TL/F/6533-2

Order Number DM7493AN
See NS Package Number N14A

Absolute Maximum Ratings (Note)

If Military/Aerospace specified devices are required, please contact the National Semiconductor Sales Office/Distributors for availability and specifications.

Supply Voltage	7V
Input Voltage	5.5V
Operating Free Air Temperature Range	
DM54	−55°C to +125°C
DM74	0°C to +70°C
Storage Temperature Range	−65°C to +150°C

Note: The "Absolute Maximum Ratings" are those values beyond which the safety of the device cannot be guaranteed. The device should not be operated at these limits. The parametric values defined in the "Electrical Characteristics" table are not guaranteed at the absolute maximum ratings. The "Recommended Operating Conditions" table will define the conditions for actual device operation.

Recommended Operating Conditions

Symbol	Parameter		DM5490			DM7490A			Units
			Min	Nom	Max	Min	Nom	Max	
V _{CC}	Supply Voltage		4.5	5	5.5	4.75	5	5.25	V
V _{IH}	High Level Input Voltage		2			2			V
V _{IL}	Low Level Input Voltage				0.8			0.8	V
I _{OH}	High Level Output Current				−0.8			−0.8	mA
I _{OL}	Low Level Output Current				16			16	mA
f _{CLK}	Clock Frequency (Note 5)	A	0		32	0		32	MHz
		B	0		16	0		16	
t _w	Pulse Width (Note 5)	A	15			15			ns
		B	30			30			
		Reset	15			15			
t _{REL}	Reset Release Time (Note 5)		25			25			ns
T _A	Free Air Operating Temperature		−55		125	0		70	°C

'90A Electrical Characteristics

over recommended operating free air temperature range (unless otherwise noted)

Symbol	Parameter	Conditions	Min	Typ (Note 1)	Max	Units
V _I	Input Clamp Voltage	V _{CC} = Min, I _I = −12 mA			−1.5	V
V _{OH}	High Level Output Voltage	V _{CC} = Min, I _{OH} = Max V _{IL} = Max, V _{IH} = Min	2.4	3.4		V
V _{OL}	Low Level Output Voltage	V _{CC} = Min, I _{OL} = Max V _{IH} = Min, V _{IL} = Max (Note 4)		0.2	0.4	V
I _I	Input Current @ Max Input Voltage	V _{CC} = Max, V _I = 5.5V			1	mA
I _{IH}	High Level Input Current	V _{CC} = Max V _I = 2.7V	A		80	μA
			Reset		40	
			B		120	
I _{IL}	Low Level Input Current	V _{CC} = Max V _I = 0.4V	A		−3.2	mA
			Reset		−1.6	
			B		−4.8	
I _{OS}	Short Circuit Output Current	V _{CC} = Max (Note 2)	DM54	−20	−57	mA
			DM74	−18	−57	
I _{CC}	Supply Current	V _{CC} = Max (Note 3)		29	42	mA

Note 1: All typicals are at V_{CC} = 5V, T_A = 25°C.

Note 2: Not more than one output should be shorted at a time.

Note 3: I_{CC} is measured with all outputs open, both RO inputs grounded following momentary connection to 4.5V, and all other inputs grounded.

Note 4: Q_A outputs are tested at I_{OL} = Max plus the limit value of I_{IL} for the B input. This permits driving the B input while maintaining full fan-out capability.

Note 5: T_A = 25°C and V_{CC} = 5V.

'90A Switching Characteristics

at $V_{CC} = 5V$ and $T_A = 25^\circ C$ (See Section 1 for Test Waveforms and Output Load)

Symbol	Parameter	From (Input) To (Output)	$R_L = 400\Omega$ $C_L = 15\text{ pF}$		Units
			Min	Max	
f_{MAX}	Maximum Clock Frequency	A to Q_A	32		MHz
		B to Q_B	16		
t_{PLH}	Propagation Delay Time Low to High Level Output	A to Q_A		16	ns
t_{PHL}	Propagation Delay Time High to Low Level Output	A to Q_A		18	ns
t_{PLH}	Propagation Delay Time Low to High Level Output	A to Q_D		48	ns
t_{PHL}	Propagation Delay Time High to Low Level Output	A to Q_D		50	ns
t_{PLH}	Propagation Delay Time Low to High Level Output	B to Q_B		16	ns
t_{PHL}	Propagation Delay Time High to Low Level Output	B to Q_B		21	ns
t_{PLH}	Propagation Delay Time Low to High Level Output	B to Q_C		32	ns
t_{PHL}	Propagation Delay Time High to Low Level Output	B to Q_C		35	ns
t_{PLH}	Propagation Delay Time Low to High Level Output	B to Q_D		32	ns
t_{PHL}	Propagation Delay Time High to Low Level Output	B to Q_D		35	ns
t_{PLH}	Propagation Delay Time Low to High Level Output	SET-9 to Q_A, Q_D		30	ns
t_{PHL}	Propagation Delay Time High to Low Level Output	SET-9 to Q_B, Q_C		40	ns
t_{PHL}	Propagation Delay Time High to Low Level Output	SET-0 Any Q		40	ns

Recommended Operating Conditions

Symbol	Parameter	DM7493A			Units
		Min	Nom	Max	
V _{CC}	Supply Voltage	4.75	5	5.25	V
V _{IH}	High Level Input Voltage	2			V
V _{IL}	Low Level Input Voltage			0.8	V
I _{OH}	High Level Output Current			-0.8	mA
I _{OL}	Low Level Output Current			16	mA
f _{CLK}	Clock Frequency (Note 5)	A	0	32	MHz
		B	0	16	
t _w	Pulse Width (Note 5)	A	15		ns
		B	30		
		Reset	15		
t _{REL}	Reset Release Time (Note 5)	25			ns
T _A	Free Air Operating Temperature	0		70	°C

'93A Electrical Characteristics

over recommended operating free air temperature range (unless otherwise noted)

Symbol	Parameter	Conditions	Min	Typ (Note 1)	Max	Units
V _I	Input Clamp Voltage	V _{CC} = Min, I _I = -12 mA			-1.5	V
V _{OH}	High Level Output Voltage	V _{CC} = Min, I _{OH} = Max V _{IL} = Max, V _{IH} = Min	2.4	3.4		V
V _{OL}	Low Level Output Voltage	V _{CC} = Min, I _{OL} = Max V _{IH} = Min, V _{IL} = Max (Note 4)		0.2	0.4	V
I _I	Input Current @ Max Input Voltage	V _{CC} = Max, V _I = 5.5V			1	mA
I _{IH}	High Level Input Current	V _{CC} = Max V _I = 2.4V	Reset		40	μA
			A		80	
			B		80	
I _{IL}	Low Level Input Current	V _{CC} = Max V _I = 0.4V	Reset		-1.6	mA
			A		-3.2	
			B		-3.2	
I _{OS}	Short Circuit Output Current	V _{CC} = Max (Note 2)	-18		-57	mA
I _{CC}	Supply Current	V _{CC} = Max (Note 3)		26	39	mA

Note 1: All typicals are at V_{CC} = 5V, T_A = 25°C.

Note 2: Not more than one output should be shorted at a time.

Note 3: I_{CC} is measured with all outputs open, both R0 inputs grounded following momentary connection to 4.5V and all other inputs grounded.

Note 4: Q_A outputs are tested at I_{OL} = Max plus the limit value of I_{IL} for the B input. This permits driving the B input while maintaining full fan-out capability.

Note 5: T_A = 25°C and V_{CC} = 5V.

'93A Switching Characteristics

at $V_{CC} = 5V$ and $T_A = 25^\circ C$ (See Section 1 for Test Waveforms and Output Load)

Symbol	Parameter	From (Input) To (Output)	$R_L = 400\Omega$ $C_L = 15\text{ pF}$		Units
			Min	Max	
f_{MAX}	Maximum Clock Frequency	A to Q_A	32		MHz
		B to Q_B	16		
t_{PLH}	Propagation Delay Time Low to High Level Output	A to Q_A		16	ns
t_{PHL}	Propagation Delay Time High to Low Level Output	A to Q_A		18	ns
t_{PLH}	Propagation Delay Time Low to High Level Output	A to Q_D		70	ns
t_{PHL}	Propagation Delay Time High to Low Level Output	A to Q_D		70	ns
t_{PLH}	Propagation Delay Time Low to High Level Output	B to Q_B		16	ns
t_{PHL}	Propagation Delay Time High to Low Level Output	B to Q_B		21	ns
t_{PLH}	Propagation Delay Time Low to High Level Output	B to Q_C		32	ns
t_{PHL}	Propagation Delay Time High to Low Level Output	B to Q_C		35	ns
t_{PLH}	Propagation Delay Time Low to High Level Output	B to Q_D		51	ns
t_{PHL}	Propagation Delay Time High to Low Level Output	B to Q_D		51	ns
t_{PHL}	Propagation Delay Time High to Low Level Output	SET-0 to Any Q		40	ns

Function Tables (Note D)

90A
BCD Count Sequence
(See Note A)

Count	Outputs			
	Q _D	Q _C	Q _B	Q _A
0	L	L	L	L
1	L	L	L	H
2	L	L	H	L
3	L	L	H	H
4	L	H	L	L
5	L	H	L	H
6	L	H	H	L
7	L	H	H	H
8	H	L	L	L
9	H	L	L	H

90A
BCD Bi-Quinary (5-2)
(See Note B)

Count	Outputs			
	Q _A	Q _D	Q _C	Q _B
0	L	L	L	L
1	L	L	L	H
2	L	L	H	L
3	L	L	H	H
4	L	H	L	L
5	H	L	L	L
6	H	L	L	H
7	H	L	H	L
8	H	L	H	H
9	H	H	L	L

93A
Count Sequence
(See Note C)

Count	Outputs			
	Q _D	Q _C	Q _B	Q _A
0	L	L	L	L
1	L	L	L	H
2	L	L	H	L
3	L	L	H	H
4	L	H	L	L
5	L	H	L	H
6	L	H	H	L
7	L	H	H	H
8	H	L	L	L
9	H	L	L	H
10	H	L	H	L
11	H	L	H	H
12	H	H	L	L
13	H	H	L	H
14	H	H	H	L
15	H	H	H	H

90A
Reset/Count Function Table

Reset Inputs				Outputs			
R0(1)	R0(2)	R9(1)	R9(2)	Q _D	Q _C	Q _B	Q _A
H	H	L	X	L	L	L	L
H	H	X	L	L	L	L	L
X	X	H	H	H	L	L	H
X	L	X	L				COUNT
L	X	L	X				COUNT
L	X	X	L				COUNT
X	L	L	X				COUNT

93A
Reset/Count Function Table

Reset Inputs		Outputs			
R0(1)	R0(2)	Q _D	Q _C	Q _B	Q _A
H	H	L	L	L	L
L	X				COUNT
X	L				COUNT

Note A: Output Q_A is connected to input B for BCD count.

Note B: Output Q_D is connected to input A for bi-quinary count.

Note C: Output Q_A is connected to input B.

Note D: H = High Level, L = Low Level, X = Don't Care.

Logic Diagrams

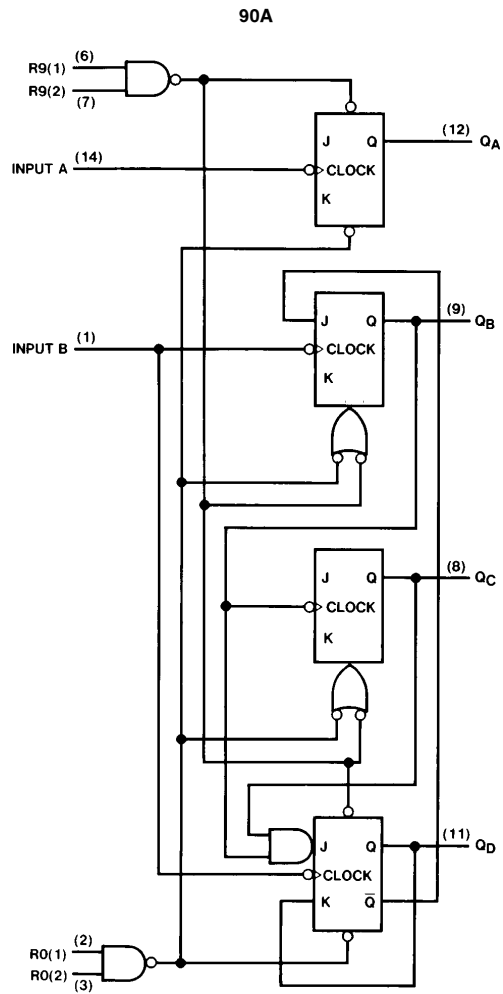

TL/F/6533-3

The J and K inputs shown without connection are for reference only and are functionally at a high level.

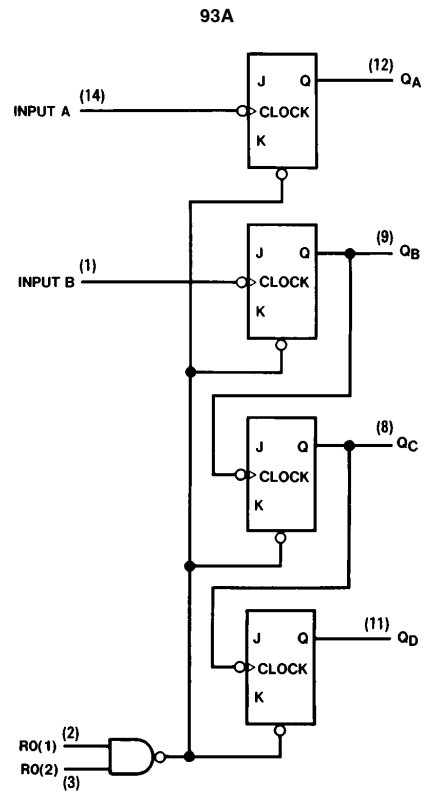

TL/F/6533-4

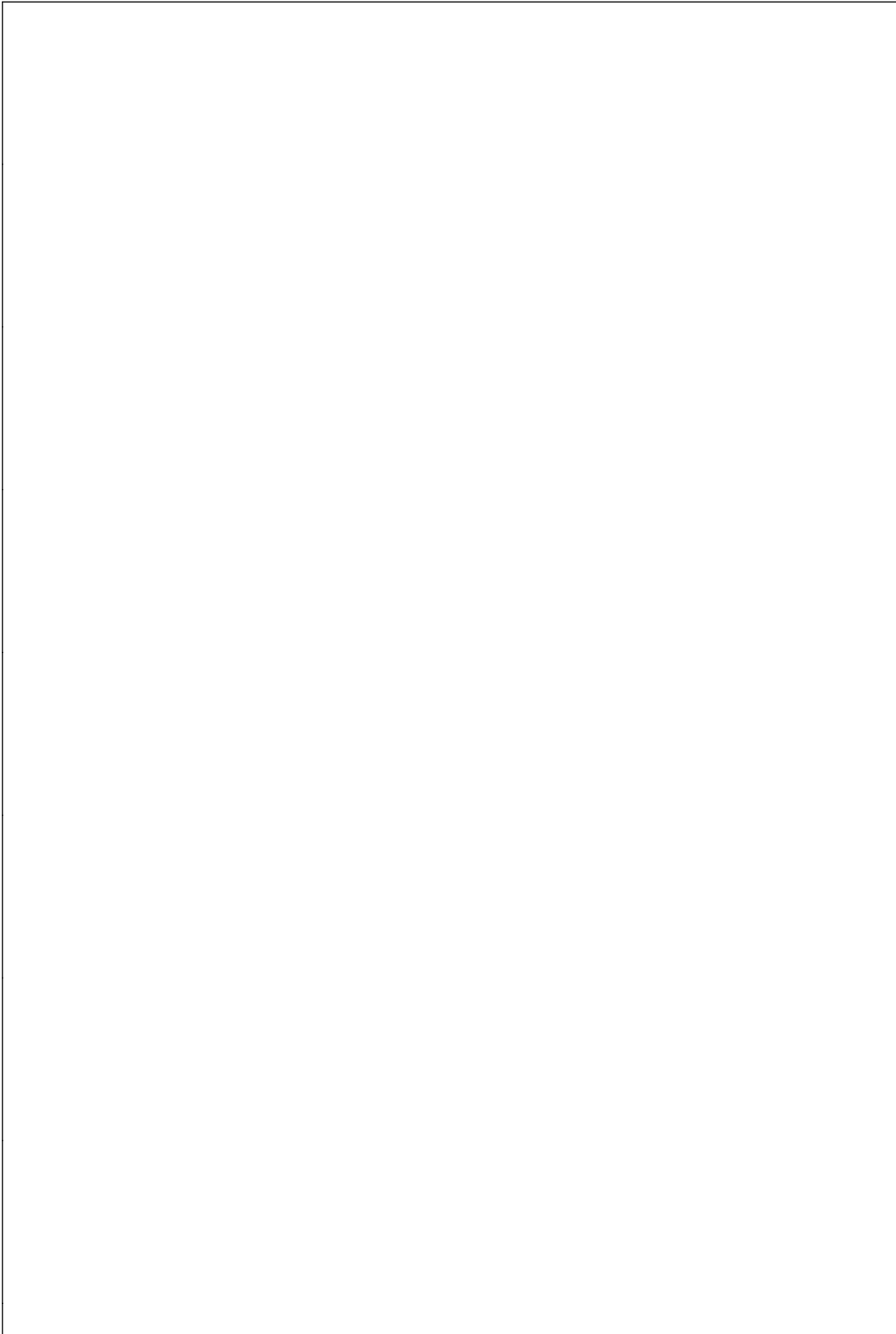

Physical Dimensions inches (millimeters)

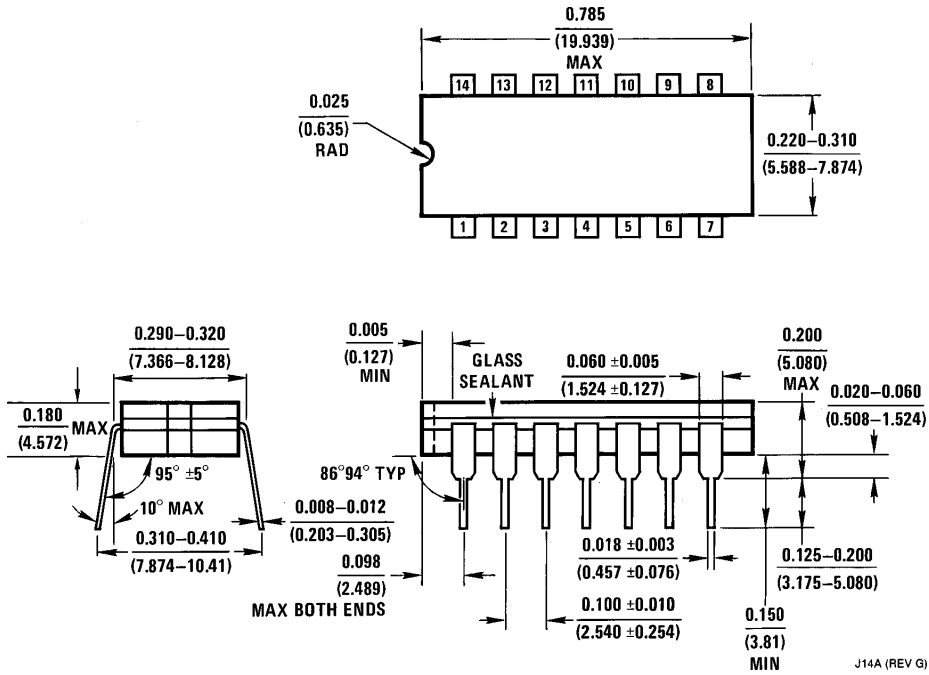

14-Lead Ceramic Dual-In-Line Package (J)
Order Number DM5490J
NS Package Number J14A

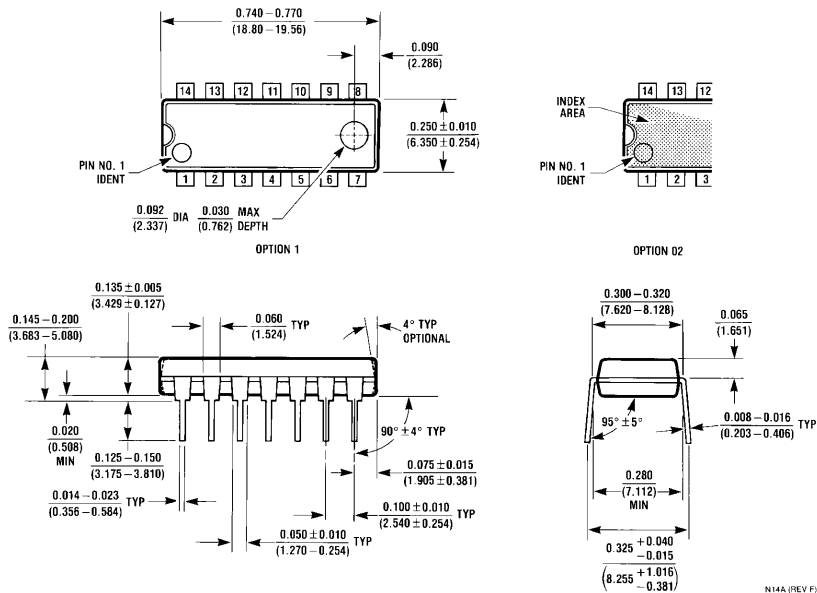

14-Lead Molded Dual-In-Line Package (N)
Order Number DM7490AN or DM7493AN
NS Package Number N14A

**DM5490/DM7490A, DM7493A
Decade and Binary Counters**

Physical Dimensions inches (millimeters) (Continued)

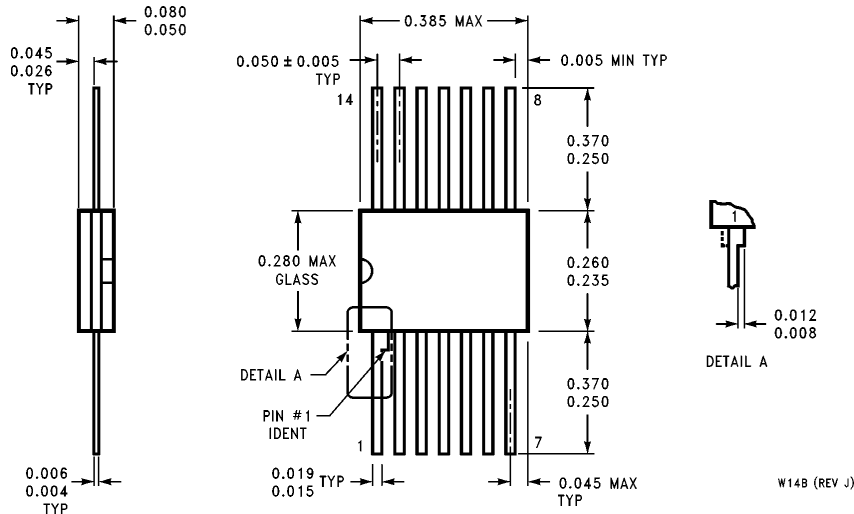

**14-Lead Ceramic Flat Package (W)
Order Number DM5490W
NS Package Number W14B**

LIFE SUPPORT POLICY

NATIONAL'S PRODUCTS ARE NOT AUTHORIZED FOR USE AS CRITICAL COMPONENTS IN LIFE SUPPORT DEVICES OR SYSTEMS WITHOUT THE EXPRESS WRITTEN APPROVAL OF THE PRESIDENT OF NATIONAL SEMICONDUCTOR CORPORATION. As used herein:

1. Life support devices or systems are devices or systems which, (a) are intended for surgical implant into the body, or (b) support or sustain life, and whose failure to perform, when properly used in accordance with instructions for use provided in the labeling, can be reasonably expected to result in a significant injury to the user.
2. A critical component is any component of a life support device or system whose failure to perform can be reasonably expected to cause the failure of the life support device or system, or to affect its safety or effectiveness.



National Semiconductor Corporation
1111 West Bardin Road
Arlington, TX 76017
Tel: 1(800) 272-9959
Fax: 1(800) 737-7018

National Semiconductor Europe
Fax: (+49) 0-180-530 85 86
Email: cnjwge@tevm2.nsc.com
Deutsch Tel: (+49) 0-180-530 85 85
English Tel: (+49) 0-180-532 78 32
Français Tel: (+49) 0-180-532 93 58
Italiano Tel: (+49) 0-180-534 16 80

National Semiconductor Hong Kong Ltd.
19th Floor, Straight Block,
Ocean Centre, 5 Canton Rd.
Tsimshatsui, Kowloon
Hong Kong
Tel: (852) 2737-1600
Fax: (852) 2736-9960

National Semiconductor Japan Ltd.
Tel: 81-043-299-2309
Fax: 81-043-299-2408

National does not assume any responsibility for use of any circuitry described, no circuit patent licenses are implied and National reserves the right at any time without notice to change said circuitry and specifications.

This datasheet has been downloaded from:

www.DatasheetCatalog.com

Datasheets for electronic components.

National Semiconductor was acquired by Texas Instruments.

http://www.ti.com/corp/docs/investor_relations/pr_09_23_2011_national_semiconductor.html

This file is the datasheet for the following electronic components:

DM5490W - <http://www.ti.com/product/dm5490w?HQS=TI-null-null-dscatalog-df-pf-null-ww>

DM5490 - <http://www.ti.com/product/dm5490?HQS=TI-null-null-dscatalog-df-pf-null-ww>

DM5490J - <http://www.ti.com/product/dm5490j?HQS=TI-null-null-dscatalog-df-pf-null-ww>



LittleDiode supplies new, hard to find or obsolete electronic components and semiconductors all over the world.

With over two million different components listed you are sure to find the part you need.

Feel free to visit us today at our online store:

LittleDiode.com

Looking forward to providing you with the best possible service.