

SELF-OSCILLATING HALF-BRIDGE DRIVER

Features

- Floating channel designed for bootstrap operation
Fully operational to +600V
Tolerant to negative transient voltage
dV/dt immune
- Undervoltage lockout
- Programmable oscillator frequency

$$f = \frac{1}{1.4 \times (R_T + 150\Omega) \times C_T}$$

- Matched propagation delay for both channels
- Micropower supply startup current of 125 μ A typ.
- Low side output in phase with R_T

Description

The IR2155 is a high voltage, high speed, self-oscillating power MOSFET and IGBT driver with both high and low side referenced output channels. Proprietary HVIC and latch immune CMOS technologies enable ruggedized monolithic construction. The front end features a programmable oscillator which is similar to the 555 timer. The output drivers feature a high pulse current buffer stage and an internal deadtime designed for minimum driver cross-conduction. Propagation delays for the two channels are matched to simplify use in 50% duty cycle applications. The floating channel can be used to drive an N-channel power

Product Summary

V_{OFFSET}	600V max.
Duty Cycle	50%
$I_{O+/-}$	210 mA / 420 mA
V_{OUT}	10 - 20V
Deadtime (typ.)	1.2 μ s

Package

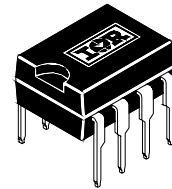

8 Lead PDIP

MOSFET or IGBT in the high side configuration that operates off a high voltage rail up to 600 volts.

Typical Connection

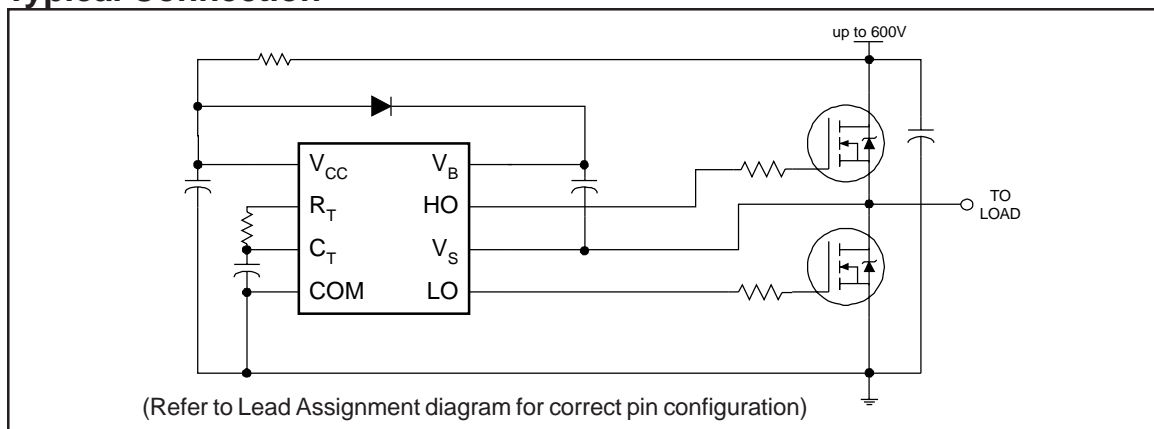

Absolute Maximum Ratings

Absolute Maximum Ratings indicate sustained limits beyond which damage to the device may occur. All voltage parameters are absolute voltages referenced to COM. The Thermal Resistance and Power Dissipation ratings are measured under board mounted and still air conditions.

Symbol	Parameter Definition	Value		Units
		Min.	Max.	
V _B	High Side Floating Supply Voltage	-0.3	625	V
V _S	High Side Floating Supply Offset Voltage	V _B - 25	V _B + 0.3	
V _{HO}	High Side Floating Output Voltage	V _S - 0.3	V _B + 0.3	
V _{LO}	Low Side Output Voltage	-0.3	V _{CC} + 0.3	
V _{RT}	R _T Voltage	-0.3	V _{CC} + 0.3	
V _{CT}	C _T Voltage	-0.3	V _{CC} + 0.3	
I _{CC}	Supply Current (Note 1)	—	25	mA
I _{RT}	R _T Output Current	-5	5	
dV _S /dt	Allowable Offset Supply Voltage Transient	—	50	V/ns
P _D	Package Power Dissipation @ T _A ≤ +25°C (8 Lead DIP)	—	1.0	W
	(8 Lead SOIC)	—	0.625	
R _{θJA}	Thermal Resistance, Junction to Ambient (8 Lead DIP)	—	125	°C/W
	(8 Lead SOIC)	—	200	
T _J	Junction Temperature	—	150	°C
T _S	Storage Temperature	-55	150	
T _L	Lead Temperature (Soldering, 10 seconds)	—	300	

Recommended Operating Conditions

The Input/Output logic timing diagram is shown in Figure 1. For proper operation the device should be used within the recommended conditions. The V_S offset rating is tested with all supplies biased at 15V differential.

Symbol	Parameter Definition	Value		Units
		Min.	Max.	
V _B	High Side Floating Supply Absolute Voltage	V _S + 10	V _S + 20	V
V _S	High Side Floating Supply Offset Voltage	—	600	
V _{HO}	High Side Floating Output Voltage	V _S	V _B	
V _{LO}	Low Side Output Voltage	0	V _{CC}	
I _{CC}	Supply Current (Note 1)	—	5	mA
T _A	Ambient Temperature	-40	125	°C

Note 1: Because of the IR2155's application specificity toward off-line supply systems, this IC contains a zener clamp structure between the chip V_{CC} and COM which has a nominal breakdown voltage of 15.6V. Therefore, the IC supply voltage is normally derived by forcing current into the supply lead (typically by means of a high value resistor connected between the chip V_{CC} and the rectified line voltage and a local decoupling capacitor from V_{CC} to COM) and allowing the internal zener clamp circuit to determine the nominal supply voltage. Therefore, this circuit should not be driven by a DC, low impedance power source of greater than V_{CLAMP}.

Dynamic Electrical Characteristics

$V_{BIAS} (V_{CC}, V_{BS}) = 12V$, $C_L = 1000 \text{ pF}$ and $T_A = 25^\circ\text{C}$ unless otherwise specified.

Symbol	Parameter Definition	Value			Units	Test Conditions
		Min.	Typ.	Max.		
t_r	Turn-On Rise Time	—	80	120	ns	
t_f	Turn-Off Fall Time	—	40	70		
DT	Deadtime	0.50	1.20	2.25	μs	
D	R_T Duty Cycle	48	50	52	%	

Static Electrical Characteristics

$V_{BIAS} (V_{CC}, V_{BS}) = 12V$, $C_L = 1000 \text{ pF}$, $C_T = 1 \text{ nF}$ and $T_A = 25^\circ\text{C}$ unless otherwise specified. The V_{IN} , V_{TH} and I_{IN} parameters are referenced to COM. The V_O and I_O parameters are referenced to COM and are applicable to the respective output leads: HO or LO.

Symbol	Parameter Definition	Value			Units	Test Conditions
		Min.	Typ.	Max.		
f_{OSC}	Oscillator Frequency	19.4	20.0	20.6	kHz	$R_T = 35.7 \text{ k}\Omega$
		94	100	106		$R_T = 7.04 \text{ k}\Omega$
V_{CLAMP}	V_{CC} Zener Shunt Clamp Voltage	14.4	15.6	16.8	V	$I_{CC} = 5 \text{ mA}$
V_{CT+}	$2/3 V_{CC}$ Threshold	7.8	8.0	8.2		
V_{CT-}	$1/3 V_{CC}$ Threshold	3.8	4.0	4.2		
V_{CTUV}	C_T Undervoltage Lockout	—	20	50	mV	$2.5V < V_{CC} < V_{CCUV}$
V_{RT+}	R_T High Level Output Voltage, $V_{CC} - R_T$	—	0	100		$I_{RT} = -100 \mu\text{A}$
		—	200	300		$I_{RT} = -1 \text{ mA}$
V_{RT-}	R_T Low Level Output Voltage	—	20	50		$I_{RT} = 100 \mu\text{A}$
		—	200	300		$I_{RT} = 1 \text{ mA}$
V_{RTUV}	R_T Undervoltage Lockout, $V_{CC} - R_T$	—	0	100		$2.5V < V_{CC} < V_{CCUV}$
V_{OH}	High Level Output Voltage, $V_{BIAS} - V_O$	—	—	100	$I_O = 0 \text{ A}$	
V_{OL}	Low Level Output Voltage, V_O	—	—	100	$I_O = 0 \text{ A}$	
I_{LK}	Offset Supply Leakage Current	—	—	50	μA	$V_B = V_S = 600V$
I_{QBS}	Quiescent V_{BS} Supply Current	—	70	150		
I_{QBSUV}	Micropower V_{BS} Supply Startup Current	—	55	125		
I_{QCC}	Quiescent V_{CC} Supply Current	—	500	1000		
I_{QCCUV}	Micropower V_{CC} Supply Startup Current	—	70	150		
I_{CT}	C_T Input Current	—	0.001	1.0		
V_{BSUV+}	V_{BS} Supply Undervoltage Positive Going Threshold	7.7	8.4	9.2		V
V_{BSUV-}	V_{BS} Supply Undervoltage Negative Going Threshold	7.3	8.1	8.9		
V_{BSUVH}	V_{BS} Supply Undervoltage Lockout Hysteresis	100	400	—	mV	
V_{CCUV+}	V_{CC} Supply Undervoltage Positive Going Threshold	7.7	8.4	9.2	V	
V_{CCUV-}	V_{CC} Supply Undervoltage Negative Going Threshold	7.4	8.1	8.9		
V_{CCUVH}	V_{CC} Supply Undervoltage Lockout Hysteresis	200	400	—	mV	
I_{O+}	Output High Short Circuit Pulsed Current	210	250	—	mA	$V_O = 0V$
I_{O-}	Output Low Short Circuit Pulsed Current	420	500	—		$V_O = 15V$

IR2155

Functional Block Diagram

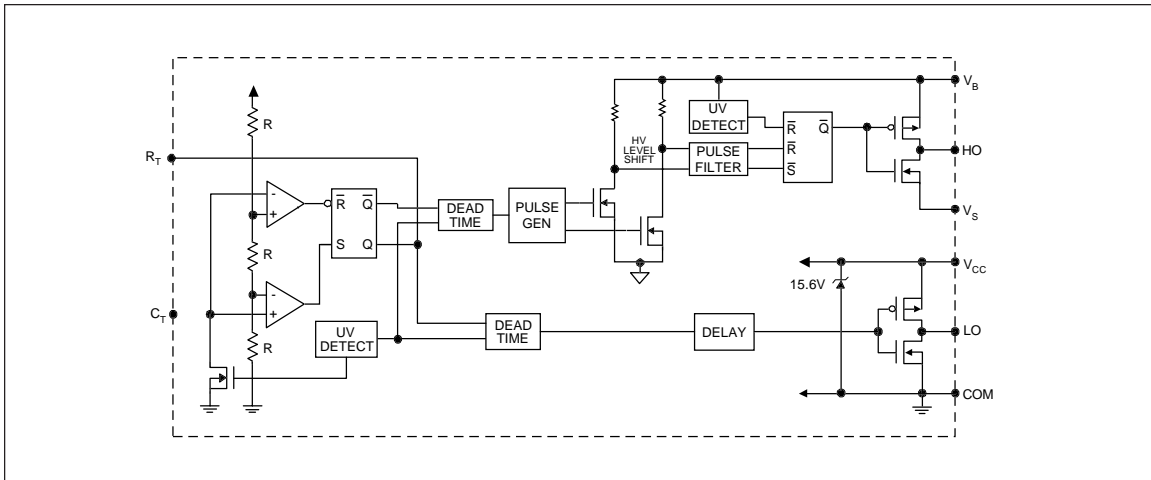

Lead Definitions

Symbol	Description
R _T	Oscillator timing resistor input, in phase with LO for normal IC operation
C _T	Oscillator timing capacitor input, the oscillator frequency according to the following equation: $f = \frac{1}{1.4 \times (R_T + 150\Omega) \times C_T}$ where 150Ω is the effective impedance of the R _T output stage
V _B	High side floating supply
HO	High side gate drive output
V _S	High side floating supply return
V _{CC}	Low side and logic fixed supply
LO	Low side gate drive output
COM	Low side return

Lead Assignments

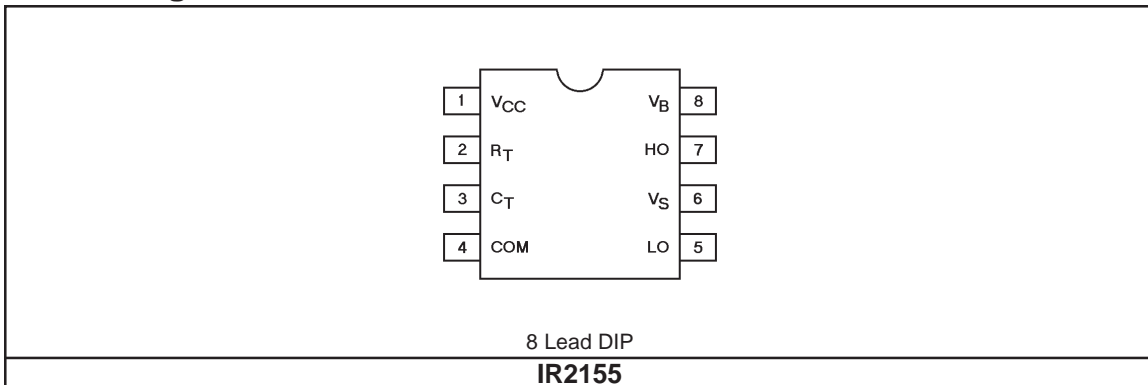

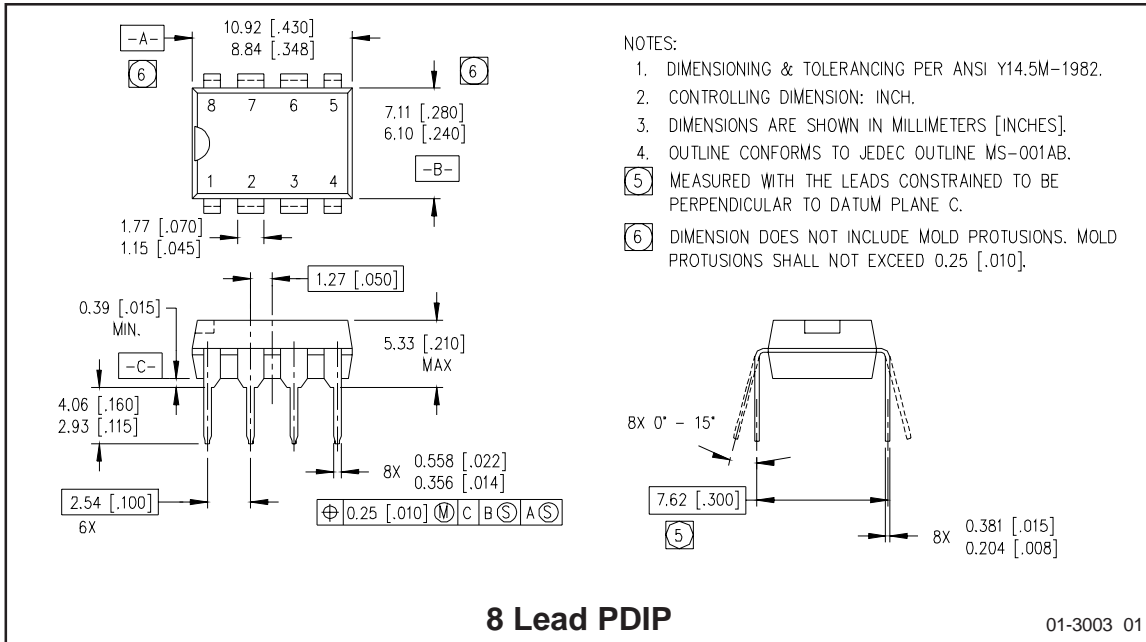

- NOTES:
1. DIMENSIONING & TOLERANCING PER ANSI Y14.5M-1982.
 2. CONTROLLING DIMENSION: INCH.
 3. DIMENSIONS ARE SHOWN IN MILLIMETERS [INCHES].
 4. OUTLINE CONFORMS TO JEDEC OUTLINE MS-001AB.
 5. MEASURED WITH THE LEADS CONSTRAINED TO BE PERPENDICULAR TO DATUM PLANE C.
 6. DIMENSION DOES NOT INCLUDE MOLD PROTUSIONS. MOLD PROTUSIONS SHALL NOT EXCEED 0.25 [.010].

8 Lead PDIP

01-3003 01

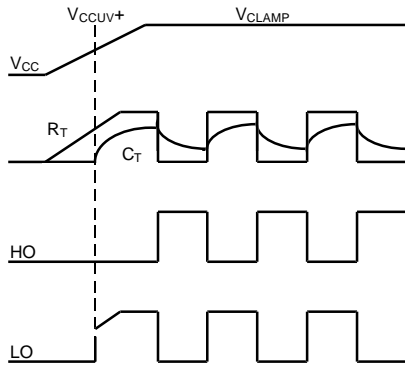

Figure 1. Input/Output Timing Diagram

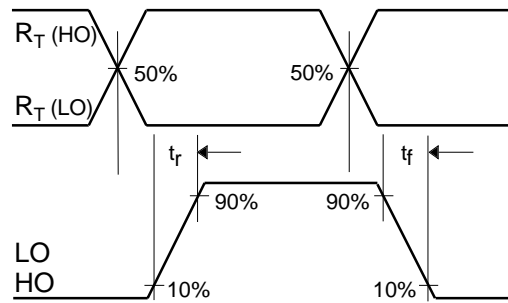

Figure 2. Switching Time Waveform Definitions

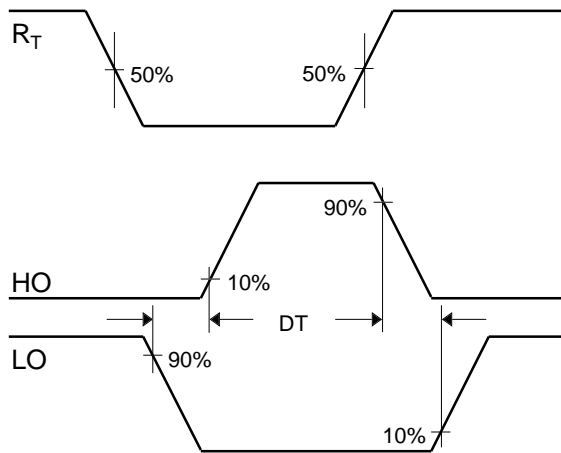

Figure 3. Deadtime Waveform Definitions



LittleDiode supplies new, hard to find or obsolete electronic components and semiconductors all over the world.

With over two million different components listed you are sure to find the part you need.

Feel free to visit us today at our online store:

LittleDiode.com

Looking forward to providing you with the best possible service.