

HD74LS390 • Dual Decade Counters

This circuit contains eight master-slave flip-flops and additional gating to implement two individual four-bit counters. The HD74LS390 incorporates dual divide-by-two and divide-by-five counters, which can be used to implement cycle lengths equal to any whole and/or cumulative multiples of 2 and/or 5 up to divide-by-100. When connected as a bi-quinary counter, the separate divide-by-two circuit can be used to provide symmetry (a square wave) at the final output stage.

■ PIN ARRANGEMENT

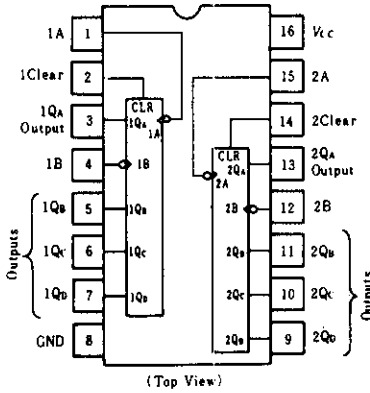

■ BLOCK DIAGRAM (1/2)

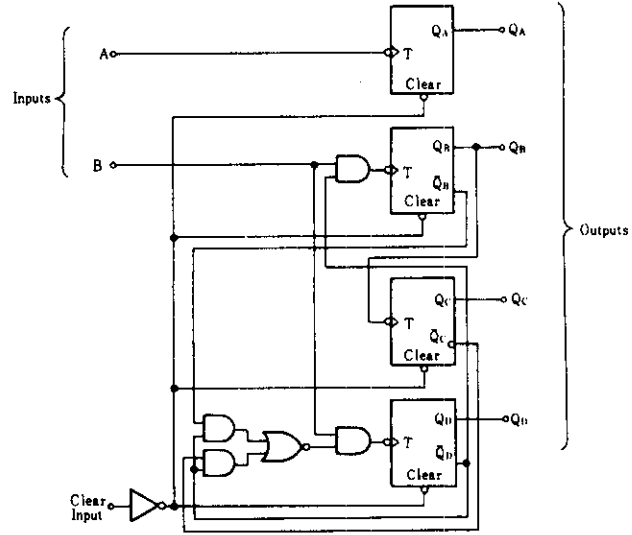

■ RECOMMENDED OPERATING CONDITIONS

Item	Symbol	min	typ	max	Unit	
Output current	I_{OH}	—	—	-400	μA	
Output current	I_{OL}	—	—	8	mA	
Count frequency	Input A	f_{count}	0	—	25	MHz
	Input B		0	—	20	
Pulse width	Input A	t_w	20	—	—	ns
	Input B		25	—	—	
	Clear		20	—	—	
Setup time	t_{su}	25	—	—	ns	

†; The arrow indicates that the falling edge of the clock pulse is used for reference.

■ FUNCTION TABLE

● BCD Count Sequence (Notes 1)

Count	Outputs			
	Q_D	Q_C	Q_B	Q_A
0	L	L	L	L
1	L	L	L	H
2	L	L	H	L
3	L	L	H	H
4	L	H	L	L
5	L	H	L	H
6	L	H	H	L
7	L	H	H	H
8	H	L	L	L
9	H	L	L	H

● Bi-Quinary (Notes 2)

Count	Outputs			
	Q_A	Q_D	Q_C	Q_B
0	L	L	L	L
1	L	L	L	H
2	L	L	H	L
3	L	L	H	H
4	L	H	L	L
5	H	L	L	L
6	H	L	L	H
7	H	L	H	L
8	H	L	H	H
9	H	H	L	L

Notes)

1. Output Q_A is connected to input B for BCD count.
2. Output Q_D is connected to input A for bi-quinary count.
3. H; high level, L; low level, X; irrelevant

■ ABSOLUTE MAXIMUM RATINGS

Item	Symbol	Ratings	Unit
Supply voltage	V_{CC}	7	V
Input voltage	Clear	7	V
	A, B	5.5	V
Operating temperature range	T_{op}	-20 ~ +75	$^{\circ}C$
Storage temperature range	T_{stg}	-65 ~ +150	$^{\circ}C$

HD74LS390

■ ELECTRICAL CHARACTERISTICS ($T_a = -20 \sim +75^\circ\text{C}$)

Item	Symbol	Test Conditions	min	typ*	max	Unit	
Input voltage	V_{IH}		2.0	—	—	V	
	V_{IL}		—	—	0.8	V	
Output voltage	V_{OH}	$V_{CC} = 4.75\text{V}$, $V_{IH} = 2\text{V}$, $V_{IL} = 0.8\text{V}$, $I_{OH} = -400\mu\text{A}$	2.7	—	—	V	
	V_{OL}	$V_{CC} = 4.75\text{V}$, $V_{IH} = 2\text{V}$, $V_{IL} = 0.8\text{V}$				V	
Input current	Clear				0.1	mA	
	Input A	$V_{CC} = 5.25\text{V}$			0.2		
	Input B				0.4		
	Clear				20		
	Input A	$V_{CC} = 5.25\text{V}$, $V_I = 2.7\text{V}$			100	μA	
	Input B				200		
	Clear				-0.4	mA	
	Input A	$V_{CC} = 5.25\text{V}$, $V_I = 0.4\text{V}$			-1.6		
	Input B				-2.4		
	Short-circuit output current	I_{OS}	$V_{CC} = 5.25\text{V}$	-20	—	-100	mA
	Supply current	I_{CC}^{**}	$V_{CC} = 5.25\text{V}$	—	15	26	mA
	Input clamp voltage	V_{IA}	$V_{CC} = 4.75\text{V}$, $I_{IN} = -18\text{mA}$	—	—	-1.5	V

* $V_{CC} = 5\text{V}$, $T_a = 25^\circ\text{C}$

** I_{CC} is measured with all outputs open, both clear inputs grounded following momentary connection to 4.5V, and all other inputs grounded.

■ SWITCHING CHARACTERISTICS ($V_{CC} = 5\text{V}$, $T_a = 25^\circ\text{C}$)

Item	Symbol	Inputs	Outputs	Test Conditions	min	typ	max	Unit
Maximum count frequency	f_{max}	A	Q_A	$C_L = 15\text{pF}$, $R_L = 2\text{k}\Omega$	25	35	—	MHz
		B	Q_B		20	30	—	
Propagation delay time	t_{PLH}	A	Q_A		—	12	20	ns
	t_{PHL}				—	13	20	
	t_{PLH}	A	Q_C		—	37	60	
	t_{PHL}				—	39	60	
	t_{PLH}	B	Q_B		—	13	21	
	t_{PHL}				—	14	21	
	t_{PLH}	B	Q_C		—	24	39	
	t_{PHL}				—	26	39	
	t_{PLH}	B	Q_D		—	13	21	
	t_{PHL}				—	14	21	
	t_{PHL}	Clear	Any	—	24	39		

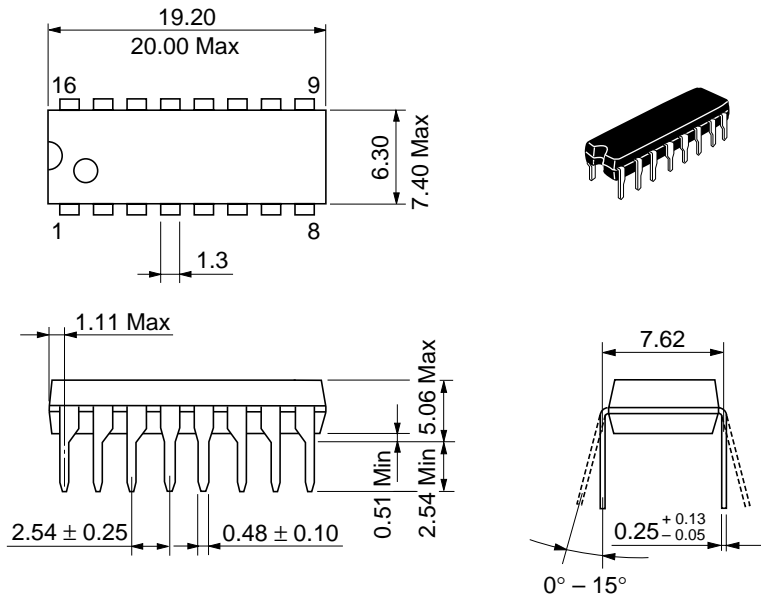

Hitachi Code	DP-16
JEDEC	Conforms
EIAJ	Conforms
Weight (reference value)	1.07 g

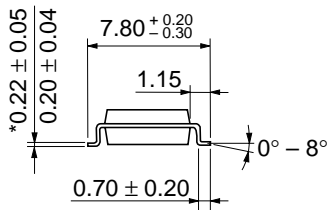
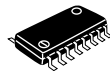
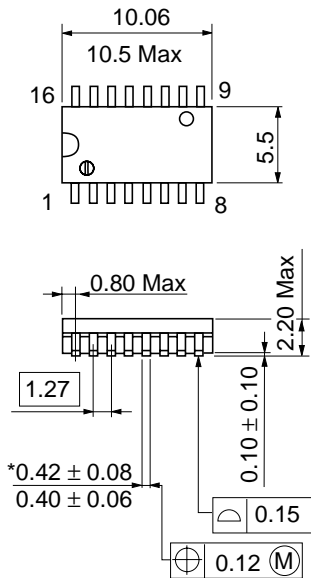

*Dimension including the plating thickness
Base material dimension

Hitachi Code	FP-16DA
JEDEC	—
EIAJ	Conforms
Weight (reference value)	0.24 g

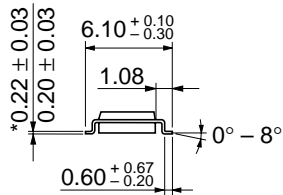
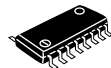
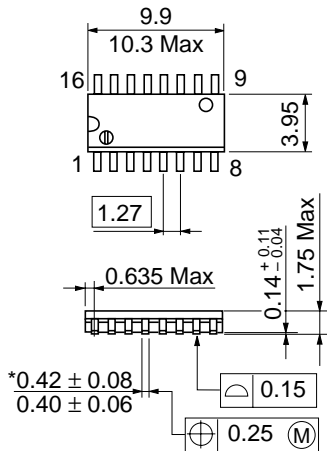

*Dimension including the plating thickness
Base material dimension

Hitachi Code	FP-16DN
JEDEC	Conforms
EIAJ	Conforms
Weight (reference value)	0.15 g

Cautions

1. Hitachi neither warrants nor grants licenses of any rights of Hitachi's or any third party's patent, copyright, trademark, or other intellectual property rights for information contained in this document. Hitachi bears no responsibility for problems that may arise with third party's rights, including intellectual property rights, in connection with use of the information contained in this document.
2. Products and product specifications may be subject to change without notice. Confirm that you have received the latest product standards or specifications before final design, purchase or use.
3. Hitachi makes every attempt to ensure that its products are of high quality and reliability. However, contact Hitachi's sales office before using the product in an application that demands especially high quality and reliability or where its failure or malfunction may directly threaten human life or cause risk of bodily injury, such as aerospace, aeronautics, nuclear power, combustion control, transportation, traffic, safety equipment or medical equipment for life support.
4. Design your application so that the product is used within the ranges guaranteed by Hitachi particularly for maximum rating, operating supply voltage range, heat radiation characteristics, installation conditions and other characteristics. Hitachi bears no responsibility for failure or damage when used beyond the guaranteed ranges. Even within the guaranteed ranges, consider normally foreseeable failure rates or failure modes in semiconductor devices and employ systemic measures such as fail-safes, so that the equipment incorporating Hitachi product does not cause bodily injury, fire or other consequential damage due to operation of the Hitachi product.
5. This product is not designed to be radiation resistant.
6. No one is permitted to reproduce or duplicate, in any form, the whole or part of this document without written approval from Hitachi.
7. Contact Hitachi's sales office for any questions regarding this document or Hitachi semiconductor products.

HITACHI

Hitachi, Ltd.

Semiconductor & Integrated Circuits.
Nippon Bldg., 2-6-2, Ohte-machi, Chiyoda-ku, Tokyo 100-0004, Japan
Tel: Tokyo (03) 3270-2111 Fax: (03) 3270-5109

URL North America : <http://semiconductor.hitachi.com/>
Europe : <http://www.hitachi-eu.com/hel/ecg>
Asia (Singapore) : <http://www.has.hitachi.com.sg/grp3/sicd/index.htm>
Asia (Taiwan) : http://www.hitachi.com.tw/E/Product/SICD_Frame.htm
Asia (HongKong) : <http://www.hitachi.com.hk/eng/bo/grp3/index.htm>
Japan : <http://www.hitachi.co.jp/Sicd/indx.htm>

For further information write to:

Hitachi Semiconductor
(America) Inc.
179 East Tasman Drive,
San Jose, CA 95134
Tel: <1> (408) 433-1990
Fax: <1> (408) 433-0223

Hitachi Europe GmbH
Electronic components Group
Dornacher Straße 3
D-85622 Feldkirchen, Munich
Germany
Tel: <49> (89) 9 9180-0
Fax: <49> (89) 9 29 30 00

Hitachi Europe Ltd.
Electronic Components Group.
Whitebrook Park
Lower Cookham Road
Maidenhead
Berkshire SL6 8YA, United Kingdom
Tel: <44> (1628) 585000
Fax: <44> (1628) 778322

Hitachi Asia Pte. Ltd.
16 Collyer Quay #20-00
Hitachi Tower
Singapore 049318
Tel: 535-2100
Fax: 535-1533

Hitachi Asia Ltd.
Taipei Branch Office
3F, Hung Kuo Building, No.167,
Tun-Hwa North Road, Taipei (105)
Tel: <886> (2) 2718-3666
Fax: <886> (2) 2718-8180

Hitachi Asia (Hong Kong) Ltd.
Group III (Electronic Components)
7/F., North Tower, World Finance Centre,
Harbour City, Canton Road, Tsim Sha Tsui,
Kowloon, Hong Kong
Tel: <852> (2) 735 9218
Fax: <852> (2) 730 0281
Telex: 40815 HITEC HX

Copyright ' Hitachi, Ltd., 1999. All rights reserved. Printed in Japan.

HITACHI



LittleDiode supplies new, hard to find or obsolete electronic components and semiconductors all over the world.

With over two million different components listed you are sure to find the part you need.

Feel free to visit us today at our online store:

LittleDiode.com

Looking forward to providing you with the best possible service.