

Radiation Hardened Synchronous 4-Bit Up/Down Counter

September 1995

Features

- 3 Micron Radiation Hardened SOS CMOS
- Total Dose 200K RAD (Si)
- SEP Effective LET No Upsets: >100 MEV-cm²/mg
- Single Event Upset (SEU) Immunity < 2 x 10⁻⁹ Errors/Bit-Day (Typ)
- Dose Rate Survivability: >1 x 10¹² RAD (Si)/s
- Dose Rate Upset >10¹⁰ RAD (Si)/s 20ns Pulse
- Latch-Up Free Under Any Conditions
- Military Temperature Range: -55°C to +125°C
- Significant Power Reduction Compared to LSTTL ICs
- DC Operating Voltage Range: 4.5V to 5.5V
- Input Logic Levels
 - VIL = 30% of VCC Max
 - VIH = 70% of VCC Min
- Input Current Levels I_i ≤ 5μA at VOL, VOH

Description

The Intersil HCS190MS is an asynchronously presettable BCD Decade synchronous counter. Presetting the counter to the number on the preset data inputs (P0 - P3) is accomplished by a low on the parallel load input (\overline{PL}). Counting occurs when (\overline{PL}) is high, Count Enable (\overline{CE}) is low and the Up/Down ($\overline{U/D}$) input is either low for up-counting or high for down-counting. The counter is incremented or decremented synchronously with the low-to-high transition of the clock.

When an overflow or underflow of the counter occurs, the Terminal Count output (TC), which is low during counting, goes high and remains high for one clock cycle. This output can be used for look-ahead carry in high speed cascading. The TC output also initiates the Ripple Clock output (\overline{RC}) which, normally high, goes low and remains low for the low-level portion of the clock pulse. These counter can be cascaded using the Ripple Carry output.

If the decade counter is preset to an illegal state or assumes an illegal state when power is applied, it will return to the normal sequence in one or two counts.

The HCS190MS utilizes advanced CMOS/SOS technology to achieve high-speed operation. This device is a member of radiation hardened, high-speed, CMOS/SOS Logic Family.

The HCS190MS is supplied in a 16 lead Ceramic flatpack (K suffix) or a SBDIP Package (D suffix).

Pinouts

16 LEAD CERAMIC DUAL-IN-LINE
METAL SEAL PACKAGE (SBDIP)
MIL-STD-1835 CDIP2-T16
TOP VIEW

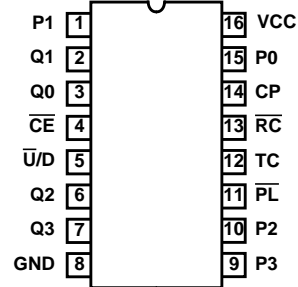

16 LEAD CERAMIC METAL SEAL
FLATPACK PACKAGE (FLATPACK)
MIL-STD-1835 CDFP4-F16
TOP VIEW

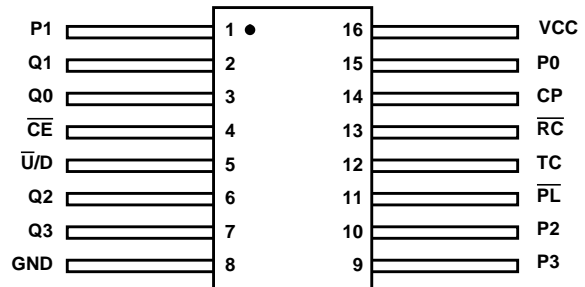

TRUTH TABLE

INPUTS				OUTPUT FUNCTION
\overline{PL}	\overline{CE}	$\overline{U/D}$	CP	
H	L	L		Count Up
H	L	H		Count Down
L	X	X	X	Preset
H	H	X	X	No Change

H = High Voltage Level X = Immaterial
L = Low Voltage Level = Positive Transition

Ordering Information

PART NUMBER	TEMPERATURE RANGE	SCREENING LEVEL	PACKAGE
HCS190DMSR	-55°C to +125°C	Intersil Class S Equivalent	16 Lead SBDIP
HCS190KMSR	-55°C to +125°C	Intersil Class S Equivalent	16 Lead Ceramic Flatpack
HCS190D/Sample	+25°C	Sample	16 Lead SBDIP
HCS190K/Sample	+25°C	Sample	16 Lead Ceramic Flatpack
HCS190HMSR	+25°C	Die	Die

Specifications HCS190MS

Absolute Maximum Ratings

Supply Voltage	-0.5V to +7.0V
Input Voltage Range, All Inputs	-0.5V to VCC +0.5V
DC Input Current, Any One Input	±10mA
DC Drain Current, Any One Output	±25mA
Storage Temperature Range (TSTG)	-65°C to +150°C
Lead Temperature (Soldering 10sec)	+265°C
Junction Temperature (TJ)	+175°C
ESD Classification	Class 1

(All Voltage Reference to the VSS Terminal)

Reliability Information

Thermal Resistance	θ_{JA}	θ_{JC}
SBDIP Package	73°C/W	24°C/W
Ceramic Flatpack Package	114°C/W	29°C/W
Maximum Package Power Dissipation at +125°C Ambient		
SBDIP Package	0.68W	
Ceramic Flatpack Package	0.44W	
If device power exceeds package dissipation capability, provide heat sinking or derate linearly at the following rate:		
SBDIP Package	13.7mW/°C	
Ceramic Flatpack Package	8.8mW/°C	
Gate Count	13 Gates	

CAUTION: Stresses above those listed in "Absolute Maximum Ratings" may cause permanent damage to the device. This is a stress only rating and operation of the device at these or any other conditions above those indicated in the operational sections of this specification is not implied.

Operating Conditions

Operating Voltage Range	+4.5V to +5.5V	Input High Voltage	VCC to 70% of VCC
Input Rise and Fall Time at 4.5V VCC (tr, tf)	100ns/V Max.	Input Low Voltage	0V to 30% of VCC
Operating Temperature Range	-55°C to +125°C		

TABLE 1. DC ELECTRICAL PERFORMANCE CHARACTERISTICS

PARAMETER	SYMBOL	(NOTE 1) CONDITIONS	GROUP A SUB- GROUPS	TEMPERATURE	LIMITS		UNITS
					MIN	MAX	
Supply Current	ICC	VCC = 5.5V, VIN = VCC or GND	1	+25°C	-	40	μA
			2, 3	+125°C, -55°C	-	750	μA
Output Current (Source)	IOH	VCC = 4.5V, VIH = 4.5V, VOU = VCC -0.4V, VIL = 0V, (Note 2)	1	+25°C	-4.8	-	mA
			2, 3	+125°C, -55°C	-4.0	-	mA
Output Current (Sink)	IOL	VCC = 4.5V, VIH = 4.5V, VOU = 0.4V, VIL = 0V, (Note 2)	1	+25°C	4.8	-	mA
			2, 3	+125°C, -55°C	4.0	-	mA
Output Voltage High	VOH	VCC = 5.5V, VIH = 3.85V, VIL = 1.65V, IOH = -50μA	1, 2, 3	+25°C, +125°C, -55°C	VCC -0.1	-	V
		VCC = 4.5V, VIH = 3.15V, VIL = 1.35V, IOH = -50μA	1, 2, 3	+25°C, +125°C, -55°C	VCC -0.1	-	V
Output Voltage Low	VOL	VCC = 5.5V, VIH = 3.85V, VIL = 1.65V, IOL = 50μA	1, 2, 3	+25°C, +125°C, -55°C	-	0.1	V
		VCC = 4.5V, VIH = 3.15V, VIL = 1.35V, IOL = 50μA	1, 2, 3	+25°C, +125°C, -55°C	-	0.1	V
Input Leakage Current	IIN	VCC = 5.5V, VIN = VCC or GND	1	+25°C	-	±0.5	μA
			2, 3	+125°C, -55°C	-	±5.0	μA
Noise Immunity Functional Test	FN	VCC = 4.5V, VIH = 3.15V, VIL = 1.35V, (Note 3)	7, 8A, 8B	+25°C, +125°C, -55°C	-	-	V

NOTES:

1. All voltages reference to device GND.
2. Force/Measure functions may be interchanged.
3. For functional tests, $VO \geq 4.0V$ is recognized as a logic "1", and $VO \leq 0.5V$ is recognized as a logic "0".

Specifications HCS190MS

TABLE 2. AC ELECTRICAL PERFORMANCE CHARACTERISTICS

PARAMETER	SYMBOL	(NOTES 1, 2) CONDITIONS	GROUP A SUB- GROUPS	TEMPERATURE	LIMITS		UNITS
					MIN	MAX	
Propagation Delay	T _{PLH}	V _{CC} = 4.5V, V _{IH} = 4.5V, V _{IL} = 0V	9	+25°C	2	30	ns
			10, 11	+125°C, -55°C	2	35	ns
$\overline{P_L}$ to Q _n	T _{PHL}	V _{CC} = 4.5V, V _{IH} = 4.5V, V _{IL} = 0V	9	+25°C	2	35	ns
			10, 11	+125°C, -55°C	2	41	ns
P _n to Q _n	T _{PLH}	V _{CC} = 4.5V, V _{IH} = 4.5V, V _{IL} = 0V	9	+25°C	2	28	ns
			10, 11	+125°C, -55°C	2	33	ns
	T _{PHL}	V _{CC} = 4.5V, V _{IH} = 4.5V, V _{IL} = 0V	9	+25°C	2	33	ns
			10, 11	+125°C, -55°C	2	38	ns
CP to Q _n	T _{PLH}	V _{CC} = 4.5V, V _{IH} = 4.5V, V _{IL} = 0V	9	+25°C	2	31	ns
			10, 11	+125°C, -55°C	2	37	ns
	T _{PHL}	V _{CC} = 4.5V, V _{IH} = 4.5V, V _{IL} = 0V	9	+25°C	2	28	ns
			10, 11	+125°C, -55°C	2	34	ns
CP to \overline{RC}	T _{PLH}	V _{CC} = 4.5V, V _{IH} = 4.5V, V _{IL} = 0V	9	+25°C	2	25	ns
			10, 11	+125°C, -55°C	2	28	ns
	T _{PHL}	V _{CC} = 4.5V, V _{IH} = 4.5V, V _{IL} = 0V	9	+25°C	2	24	ns
			10, 11	+125°C, -55°C	2	26	ns
CP to TC	T _{PLH}	V _{CC} = 4.5V, V _{IH} = 4.5V, V _{IL} = 0V	9	+25°C	2	41	ns
			10, 11	+125°C, -55°C	2	49	ns
	T _{PHL}	V _{CC} = 4.5V, V _{IH} = 4.5V, V _{IL} = 0V	9	+25°C	2	40	ns
			10, 11	+125°C, -55°C	2	47	ns
$\overline{U/D}$ to \overline{RC}	T _{PLH}	V _{CC} = 4.5V, V _{IH} = 4.5V, V _{IL} = 0V	9	+25°C	2	37	ns
			10, 11	+125°C, -55°C	2	40	ns
	T _{PHL}	V _{CC} = 4.5V, V _{IH} = 4.5V, V _{IL} = 0V	9	+25°C	2	34	ns
			10, 11	+125°C, -55°C	2	40	ns
$\overline{U/D}$ to TC	T _{PLH}	V _{CC} = 4.5V, V _{IH} = 4.5V, V _{IL} = 0V	9	+25°C	2	40	ns
			10, 11	+125°C, -55°C	2	43	ns
	T _{PHL}	V _{CC} = 4.5V, V _{IH} = 4.5V, V _{IL} = 0V	9	+25°C	2	40	ns
			10, 11	+125°C, -55°C	2	36	ns
\overline{CE} to \overline{RC}	T _{PLH}	V _{CC} = 4.5V, V _{IH} = 4.5V, V _{IL} = 0V	9	+25°C	2	24	ns
			10, 11	+125°C, -55°C	2	25	ns
	T _{PHL}	V _{CC} = 4.5V, V _{IH} = 4.5V, V _{IL} = 0V	9	+25°C	2	26	ns
			10, 11	+125°C, -55°C	2	26	ns

NOTES:

1. All voltages referenced to device GND.
2. AC measurements assume R_L = 500Ω, C_L = 50pF, Input TR = TF = 3ns.

Specifications HCS190MS

TABLE 3. ELECTRICAL PERFORMANCE CHARACTERISTICS

PARAMETER	SYMBOL	CONDITIONS	NOTES	TEMPERATURE	LIMITS		UNITS
					MIN	MAX	
Capacitance Power Dissipation	CPD	VCC = 5.0V, VIH = 5.0V, VIL = 0V, f = 1MHz	1	+25°C	-	36	pF
			1	+125°C, -55°C	-	62	pF
Input Capacitance	CIN	VCC = 5.0V, VIH = 5.0V, VIL = 0V, f = 1MHz	1	+25°C	-	10	pF
			1	+125°C, -55°C	-	10	pF
Setup Time Pn to \overline{PL}	TSU	VCC = 4.5V, VIH = 4.5V, VIL = 0V	1	+25°C	12	-	ns
			1	+125°C, -55°C	18	-	ns
\overline{CE} to CP	TSU	VCC = 4.5V, VIH = 4.5V, VIL = 0V	1	+25°C	12	-	ns
			1	+125°C, -55°C	18	-	ns
$\overline{U/D}$ to CP	TSU	VCC = 4.5V, VIH = 4.5V, VIL = 0V	1	+25°C	18	-	ns
			1	+125°C, -55°C	27	-	ns
Hold Time Pn to \overline{PL}	TH	VCC = 4.5V, VIH = 4.5V, VIL = 0V	1	+25°C	2	-	ns
			1	+125°C, -55°C	2	-	ns
\overline{CE} to CP	TH	VCC = 4.5V, VIH = 4.5V, VIL = 0V	1	+25°C	2	-	ns
			1	+125°C, -55°C	2	-	ns
$\overline{U/D}$ to CP	TH	VCC = 4.5V, VIH = 4.5V, VIL = 0V	1	+25°C	0	-	ns
			1	+125°C, -55°C	0	-	ns
Pulse Width Time CP	TW	VCC = 4.5V, VIH = 4.5V, VIL = 0V	1	+25°C	16	-	ns
			1	+125°C, -55°C	24	-	ns
\overline{PL}	TW	VCC = 4.5V, VIH = 4.5V, VIL = 0V	1	+25°C	20	-	ns
			1	+125°C, -55°C	30	-	ns
Recovery Time	TREC	VCC = 4.5V, VIH = 4.5V, VIL = 0V	1	+25°C	12	-	ns
			1	+125°C, -55°C	18	-	ns
Maximum Frequency	FMAX	VCC = 4.5V, VIH = 4.5V, VIL = 0V	1	+25°C	30	-	ns
			1	+125°C, -55°C	20	-	ns
Output Transition Time	TTHL TTLH	VCC = 4.5V, VIH = 4.5V, VIL = 0V	1	+25°C	1	15	ns
			1	+125°C, -55°C	1	22	ns

NOTE:

- The parameters listed in Table 3 are controlled via design or process parameters. Min and Max Limits are guaranteed but not directly tested. These parameters are characterized upon initial design release and upon design changes which affect these characteristics.

TABLE 4. POST IRRADIATION ELECTRICAL PERFORMANCE CHARACTERISTICS

PARAMETER	SYMBOL	(NOTE 1) CONDITIONS	TEMPERATURE	200K RAD LIMITS		UNITS
				MIN	MAX	
Supply Current	ICC	VCC = 5.5V, VIN = VCC or GND	+25°C	-	0.75	mA
Output Current (Source)	IOH	VCC = VIH = 4.5V, VOUT = VCC - 0.4V, VIL = 0	+25°C	-4.0	-	mA
Output Current (Sink)	IOL	VCC = VIH = 4.5V, VOUT = 0.4V, VIL = 0	+25°C	4.0	-	mA

Specifications HCS190MS

TABLE 4. POST IRRADIATION ELECTRICAL PERFORMANCE CHARACTERISTICS (Continued)

PARAMETER	SYMBOL	(NOTE 1) CONDITIONS	TEMPERATURE	200K RAD LIMITS		UNITS
				MIN	MAX	
Output Voltage High	VOH	VCC = 5.5V, VIH = 3.85V, VIL = 1.65V, IOH = -50μA	+25°C	VCC -0.1	-	V
		VCC = 4.5V, VIH = 3.15V, VIL = 1.35V, IOH = -50μA	+25°C	VCC -0.1	-	V
Output Voltage Low	VOL	VCC = 5.5V, VIH = 3.85V, VIL = 1.65V, IOL = 50μA	+25°C	-	0.1	V
		VCC = 4.5V, VIH = 3.15V, VIL = 1.35V, IOL = 50μA	+25°C	-	0.1	V
Input Leakage Current	IIN	VCC = 5.5V, VIN = VCC or GND	+25°C	-	±5	μA
Noise Immunity Functional Test	FN	VCC = 4.5V, VIH = 3.15V, VIL = 1.35V, (Note 2)	+25°C	-	-	V
Propagation Delay	TPLH	VCC = 4.5V, VIH = 4.5V, VIL = 0V	+25°C	2	35	ns
$\overline{P}L$ to Qn	TPHL	VCC = 4.5V, VIH = 4.5V, VIL = 0V	+25°C	2	41	ns
Pn to Qn	TPLH	VCC = 4.5V, VIH = 4.5V, VIL = 0V	+25°C	2	33	ns
	TPHL	VCC = 4.5V, VIH = 4.5V, VIL = 0V	+25°C	2	38	ns
CP to Qn	TPLH	VCC = 4.5V, VIH = 4.5V, VIL = 0V	+25°C	2	37	ns
	TPHL	VCC = 4.5V, VIH = 4.5V, VIL = 0V	+25°C	2	34	ns
CP to $\overline{R}C$	TPLH	VCC = 4.5V, VIH = 4.5V, VIL = 0V	+25°C	2	28	ns
	TPHL	VCC = 4.5V, VIH = 4.5V, VIL = 0V	+25°C	2	26	ns
CP to TC	TPLH	VCC = 4.5V, VIH = 4.5V, VIL = 0V	+25°C	2	49	ns
	TPHL	VCC = 4.5V, VIH = 4.5V, VIL = 0V	+25°C	2	47	ns
\overline{U}/D to $\overline{R}C$	TPLH	VCC = 4.5V, VIH = 4.5V, VIL = 0V	+25°C	2	40	ns
	TPHL	VCC = 4.5V, VIH = 4.5V, VIL = 0V	+25°C	2	40	ns
\overline{U}/D to TC	TPLH	VCC = 4.5V, VIH = 4.5V, VIL = 0V	+25°C	2	43	ns
	TPHL	VCC = 4.5V, VIH = 4.5V, VIL = 0V	+25°C	2	36	ns
$\overline{C}E$ to $\overline{R}C$	TPLH	VCC = 4.5V, VIH = 4.5V, VIL = 0V	+25°C	2	25	ns
	TPHL	VCC = 4.5V, VIH = 4.5V, VIL = 0V	+25°C	2	26	ns

NOTES:

1. All voltages referenced to device GND.
2. For functional tests, $V_O \geq 4.0V$ is recognized as a logic "1", and $V_O \leq 0.5V$ is recognized as a logic "0".

TABLE 5. BURN-IN AND OPERATING LIFE TEST, DELTA PARAMETERS (+25°C)

PARAMETER	GROUP B SUBGROUP	DELTA LIMIT
ICC	5	12μA
IOL/IOH	5	-15% of 0 Hour

Specifications HCS190MS

TABLE 6. APPLICABLE SUBGROUPS

CONFORMANCE GROUPS		METHOD	GROUP A SUBGROUPS	READ AND RECORD
Initial Test (Preburn-In)		100%/5004	1, 7, 9	ICC, IOL/H, IOZL/H
Interim Test I (Postburn-In)		100%/5004	1, 7, 9	ICC, IOL/H, IOZL/H
Interim Test II (Postburn-In)		100%/5004	1, 7, 9	ICC, IOL/H, IOZL/H
PDA		100%/5004	1, 7, 9, Deltas	
Interim Test III (Postburn-In)		100%/5004	1, 7, 9	ICC, IOL/H, IOZL/H
PDA		100%/5004	1, 7, 9, Deltas	
Final Test		100%/5004	2, 3, 8A, 8B, 10, 11	
Group A (Note 1)		Sample/5005	1, 2, 3, 7, 8A, 8B, 9, 10, 11	
Group B	Subgroup B-5	Sample/5005	1, 2, 3, 7, 8A, 8B, 9, 10, 11, Deltas	Subgroups 1, 2, 3, 9, 10, 11
	Subgroup B-6	Sample/5005	1, 7, 9	
Group D		Sample/5005	1, 7, 9	

NOTE:

1. Alternate group A testing in accordance with Method 5005 of Mil-Std-883 may be exercised.

TABLE 7. TOTAL DOSE IRRADIATION

CONFORMANCE GROUPS	METHOD	TEST		READ AND RECORD	
		PRE RAD	POST RAD	PRE RAD	POST RAD
Group E Subgroup 2	5005	1, 7, 9	Table 4	1, 7, 9	Table 4 (Note 1)

NOTE:

1. Except FN test which will be performed 100% go/no-go.

TABLE 8. STATIC AND DYNAMIC BURN-IN TEST CONNECTIONS

OPEN	GROUND	1/2 VCC = 3V ± 0.5V	VCC = 6V ± 0.5V	OSCILLATOR	
				50kHz	25kHz
STATIC I BURN-IN (Note 1)					
2, 3, 6, 7, 12, 13	1, 4, 5, 8, 9, 10, 11, 14, 15	-	16	-	-
STATIC II BURN-IN (Note 1)					
2, 3, 6, 7, 12, 13	8	-	1, 4, 5, 9, 10, 11, 14, 15, 16	-	-
DYNAMIC BURN-IN (Note 2)					
-	1, 4, 5, 8, 9, 10, 15	2, 3, 6, 7, 12, 13	11, 16	14	-

NOTES:

1. Each pin except VCC and GND will have a series resistor of 10K ± 5%.
2. Each pin except VCC and GND will have a series resistor of 1K ± 5%.

TABLE 9. IRRADIATION TEST CONNECTIONS

OPEN	GROUND	VCC = 5V ± 0.5V
2, 3, 6, 7, 12, 13	8	1, 4, 5, 9, 10, 11, 14, 15, 16

NOTE: Each pin except VCC and GND will have a resistor of 47KΩ ± 5% for irradiation testing. Group E, Subgroup 2, sample size is 4 dice/wafer 0 failures.

Intersil Space Level Product Flow - 'MS'

Wafer Lot Acceptance (All Lots) Method 5007 (Includes SEM)	100% Interim Electrical Test 1 (T1)
GAMMA Radiation Verification (Each Wafer) Method 1019, 4 Samples/Wafer, 0 Rejects	100% Delta Calculation (T0-T1)
100% Nondestructive Bond Pull, Method 2023	100% Static Burn-In 2, Condition A or B, 24 hrs. min., +125°C min., Method 1015
Sample - Wire Bond Pull Monitor, Method 2011	100% Interim Electrical Test 2 (T2)
Sample - Die Shear Monitor, Method 2019 or 2027	100% Delta Calculation (T0-T2)
100% Internal Visual Inspection, Method 2010, Condition A	100% PDA 1, Method 5004 (Notes 1 and 2)
100% Temperature Cycle, Method 1010, Condition C, 10 Cycles	100% Dynamic Burn-In, Condition D, 240 hrs., +125°C or Equivalent, Method 1015
100% Constant Acceleration, Method 2001, Condition per Method 5004	100% Interim Electrical Test 3 (T3)
100% PIND, Method 2020, Condition A	100% Delta Calculation (T0-T3)
100% External Visual	100% PDA 2, Method 5004 (Note 2)
100% Serialization	100% Final Electrical Test
100% Initial Electrical Test (T0)	100% Fine/Gross Leak, Method 1014
100% Static Burn-In 1, Condition A or B, 24 hrs. min., +125°C min., Method 1015	100% Radiographic, Method 2012 (Note 3)
	100% External Visual, Method 2009
	Sample - Group A, Method 5005 (Note 4)
	100% Data Package Generation (Note 5)

NOTES:

1. Failures from Interim electrical test 1 and 2 are combined for determining PDA 1.
2. Failures from subgroup 1, 7, 9 and deltas are used for calculating PDA. The maximum allowable PDA = 5% with no more than 3% of the failures from subgroup 7.
3. Radiographic (X-Ray) inspection may be performed at any point after serialization as allowed by Method 5004.
4. Alternate Group A testing may be performed as allowed by MIL-STD-883, Method 5005.
5. Data Package Contents:
 - Cover Sheet (Intersil Name and/or Logo, P.O. Number, Customer Part Number, Lot Date Code, Intersil Part Number, Lot Number, Quantity).
 - Wafer Lot Acceptance Report (Method 5007). Includes reproductions of SEM photos with percent of step coverage.
 - GAMMA Radiation Report. Contains Cover page, disposition, Rad Dose, Lot Number, Test Package used, Specification Numbers, Test equipment, etc. Radiation Read and Record data on file at Intersil.
 - X-Ray report and film. Includes penetrometer measurements.
 - Screening, Electrical, and Group A attributes (Screening attributes begin after package seal).
 - Lot Serial Number Sheet (Good units serial number and lot number).
 - Variables Data (All Delta operations). Data is identified by serial number. Data header includes lot number and date of test.
 - The Certificate of Conformance is a part of the shipping invoice and is not part of the Data Book. The Certificate of Conformance is signed by an authorized Quality Representative.

All Intersil semiconductor products are manufactured, assembled and tested under **ISO9000** quality systems certification.

Intersil products are sold by description only. Intersil Corporation reserves the right to make changes in circuit design and/or specifications at any time without notice. Accordingly, the reader is cautioned to verify that data sheets are current before placing orders. Information furnished by Intersil is believed to be accurate and reliable. However, no responsibility is assumed by Intersil or its subsidiaries for its use; nor for any infringements of patents or other rights of third parties which may result from its use. No license is granted by implication or otherwise under any patent or patent rights of Intersil or its subsidiaries.

For information regarding Intersil Corporation and its products, see web site <http://www.intersil.com>

Sales Office Headquarters

NORTH AMERICA

Intersil Corporation
P. O. Box 883, Mail Stop 53-204
Melbourne, FL 32902
TEL: (321) 724-7000
FAX: (321) 724-7240

EUROPE

Intersil SA
Mercure Center
100, Rue de la Fusee
1130 Brussels, Belgium
TEL: (32) 2.724.2111
FAX: (32) 2.724.22.05

ASIA

Intersil (Taiwan) Ltd.
Taiwan Limited
7F-6, No. 101 Fu Hsing North Road
Taipei, Taiwan
Republic of China
TEL: (886) 2 2716 9310
FAX: (886) 2 2715 3029

Propagation Delay Timing Diagram

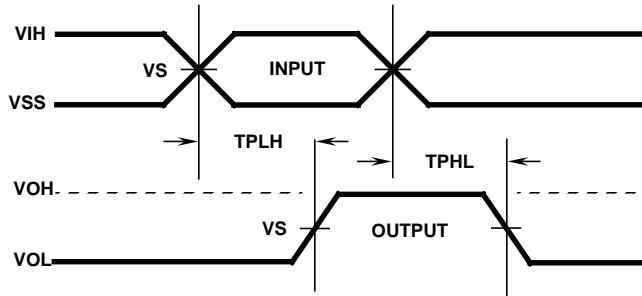

Transition Timing Diagram

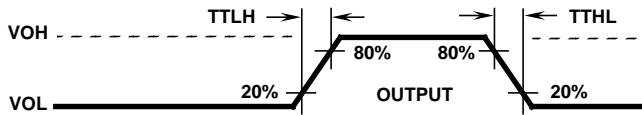

VOLTAGE LEVELS

PARAMETER	HCS	UNITS
VCC	4.50	V
VIH	4.50	V
VS	2.25	V
VIL	0	V
GND	0	V

Propagation Delay Load Circuit

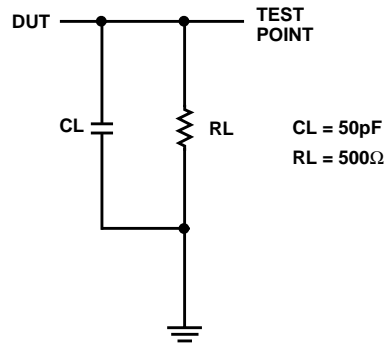

Pulse Width, Setup, Hold Timing Diagram Positive Edge Trigger

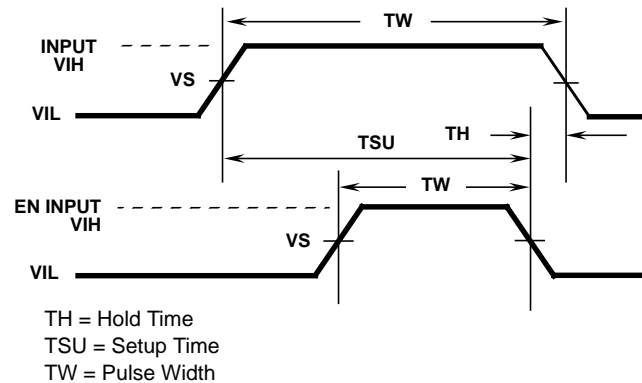

AC VOLTAGE LEVELS

PARAMETER	HCS	UNITS
VCC	4.50	V
VIH	4.50	V
VS	2.25	V
VIL	0	V
GND	0	V

Propagation Delay Load Circuit

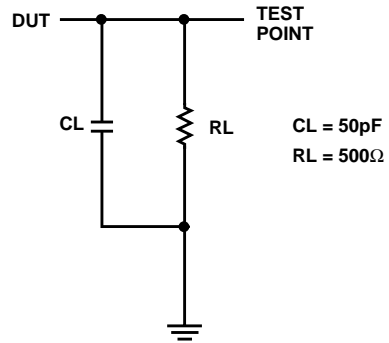

HCS190MS

Die Characteristics

DIE DIMENSIONS:

104 x 86 (mils)
2.65 x 2.19 (mm)

METALLIZATION:

Type: Si - Al
Thickness: $11\text{k}\text{\AA} \pm 1\text{k}\text{\AA}$

GLASSIVATION:

Type: SiO_2
Thickness: $13\text{k}\text{\AA} \pm 2.6\text{k}\text{\AA}$

WORST CASE CURRENT DENSITY:

$<2.0 \times 10^5 \text{ A/cm}^2$

BOND PAD SIZE:

4 x 4 (mils)
100 x 100 μm

Metallization Mask Layout

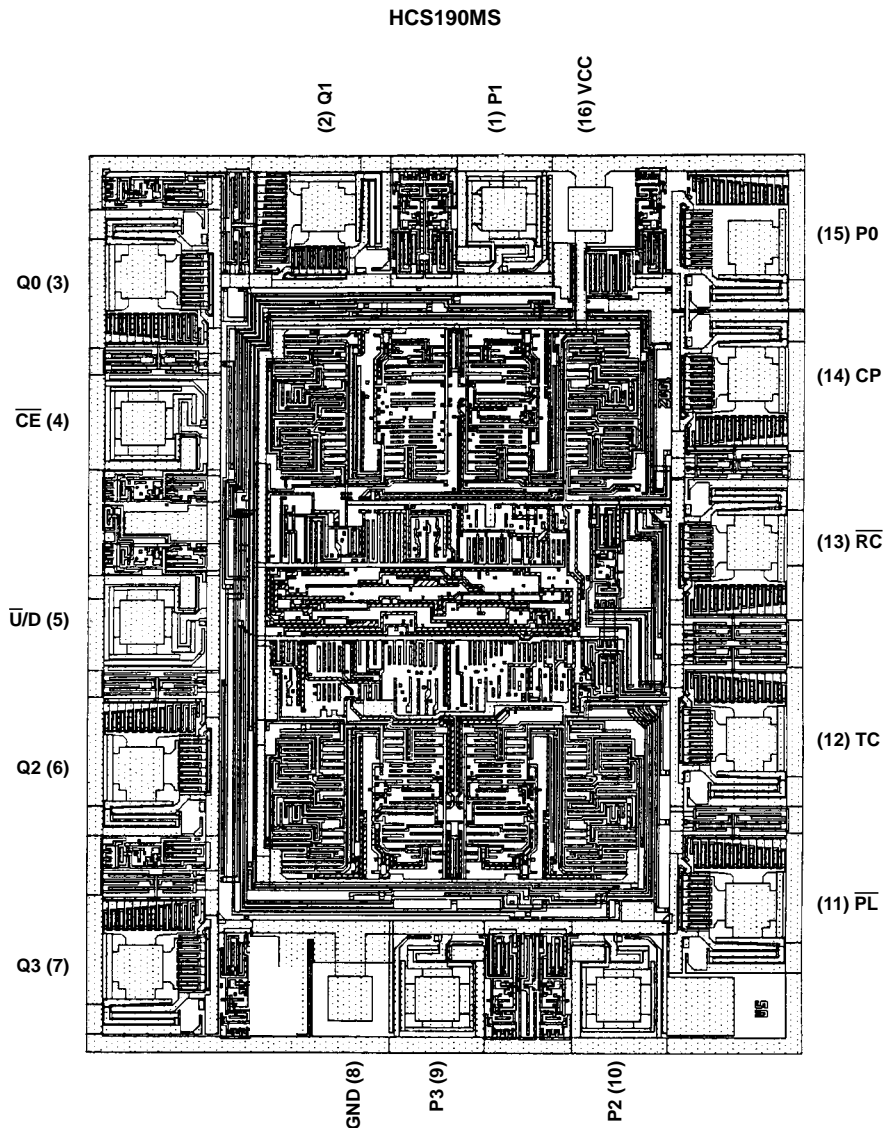

NOTE: The die diagram is a generic plot from a similar HCS device. It is intended to indicate approximate die size and bond pad location. The mask series for the HCS190 is TA14344A.

This datasheet has been downloaded from:

www.DatasheetCatalog.com

Datasheets for electronic components.



LittleDiode supplies new, hard to find or obsolete electronic components and semiconductors all over the world.

With over two million different components listed you are sure to find the part you need.

Feel free to visit us today at our online store:

LittleDiode.com

Looking forward to providing you with the best possible service.