

12W AUDIO AMPLIFIER ($V_s = 22V$, $R_L = 4\Omega$)

DESCRIPTION

The TDA2008 is a monolithic class B audio power amplifier in Pentawatt® package designed for driving low impedance loads (down to 3.2Ω). The device provides a high output current capability (up to 3A), very low harmonic and crossover distortion.

In addition, the device offers the following features:

- very low number of external components;
- assembly ease, due to Pentawatt® power package with no electrical insulations requirements;
- space and cost saving;
- high reliability;
- flexibility in use;
- thermal protection.

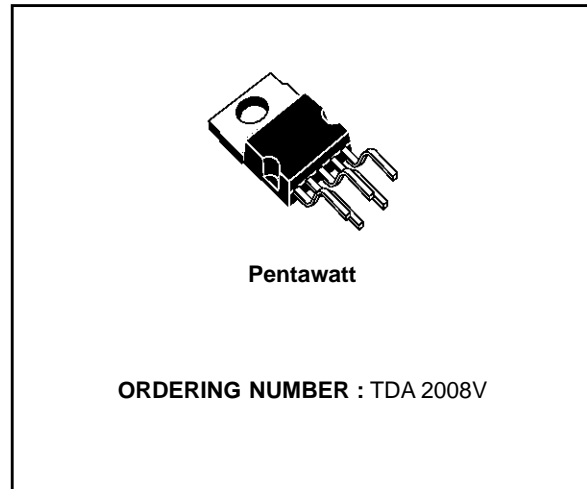

TYPICAL APPLICATION CIRCUIT

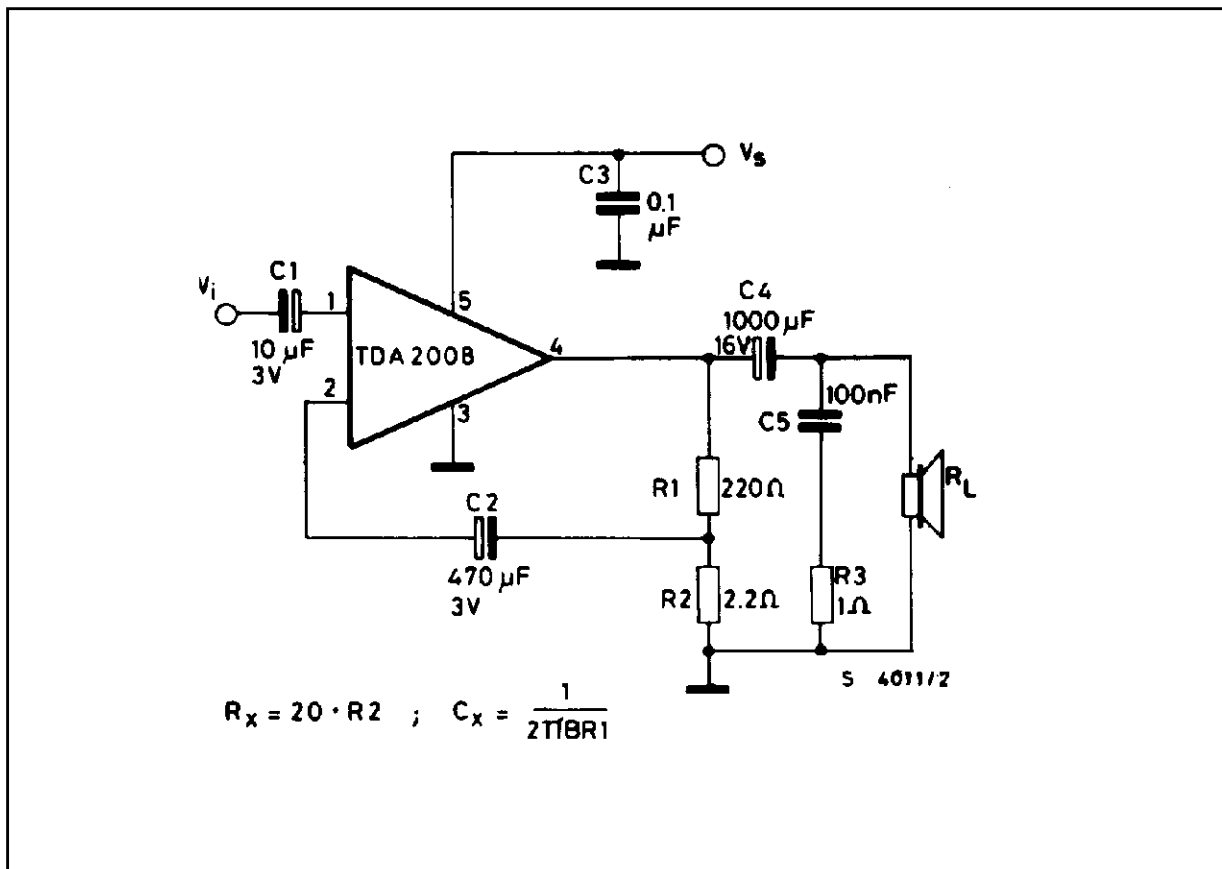

TDA2008

PIN CONNECTION (top view)

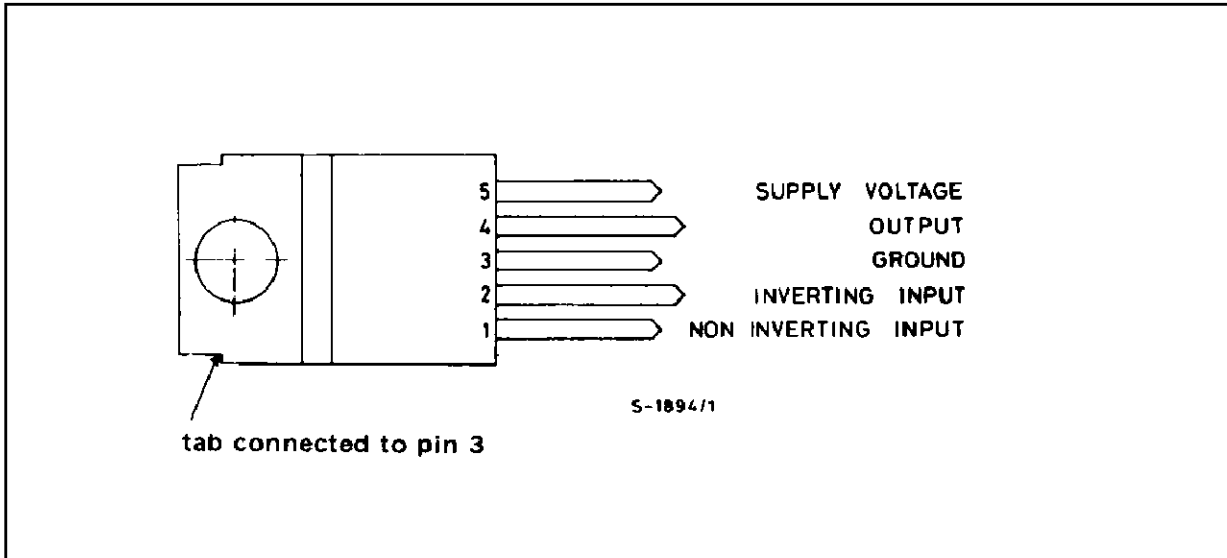

ABSOLUTE MAXIMUM RATINGS

Symbol	Parameter	Value	Unit
V_s	DC supply voltage	28	V
I_o	Output peak current (repetitive)	3	A
I_o	Output peak current (non repetitive)	4	A
P_{tot}	Power dissipation at $T_{case} = 90^\circ\text{C}$	20	W
T_{stg}, T_j	Storage and junction temperature	- 40 to 150	$^\circ\text{C}$

SCHEMATIC DIAGRAM

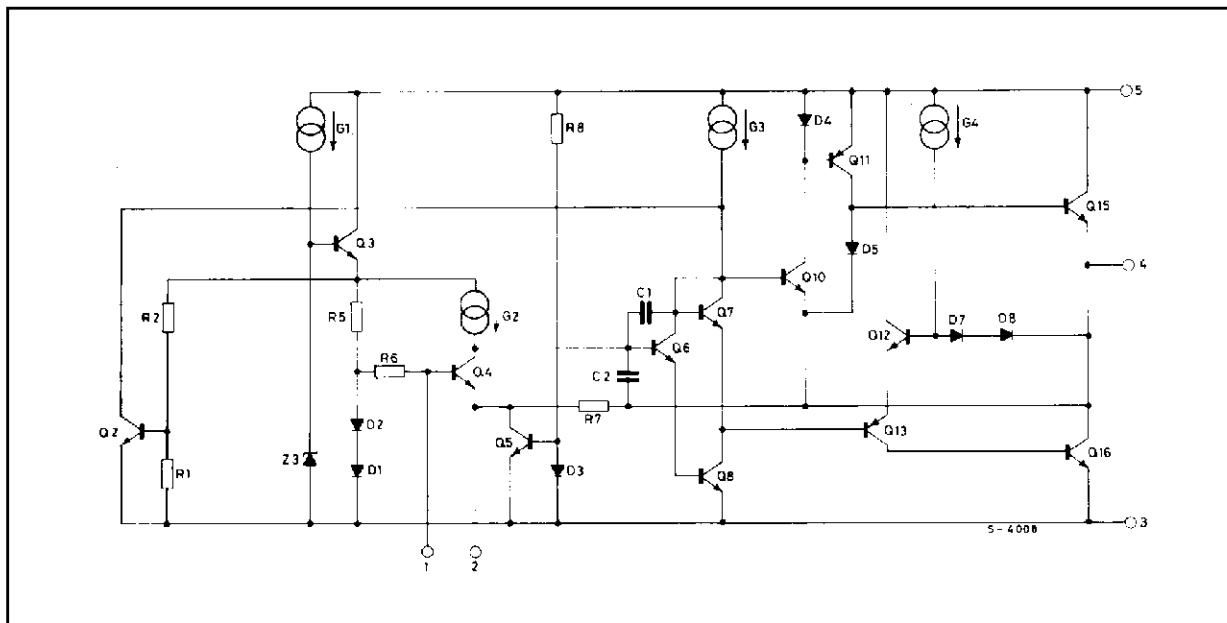

DC TEST CIRCUIT

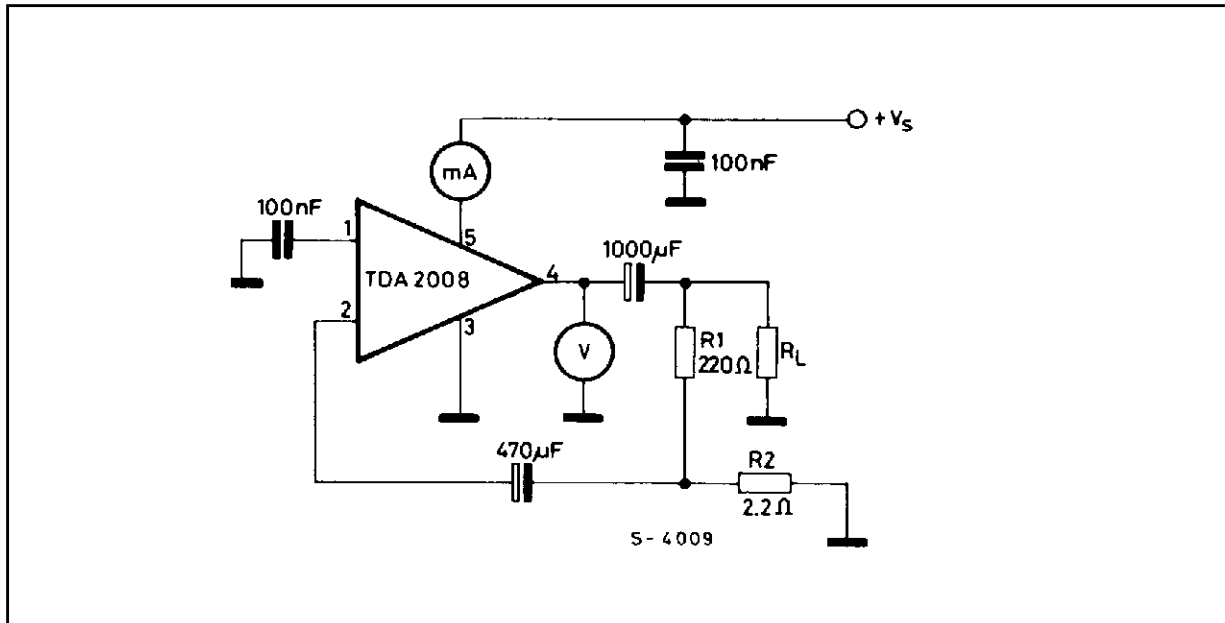

AC TEST CIRCUIT

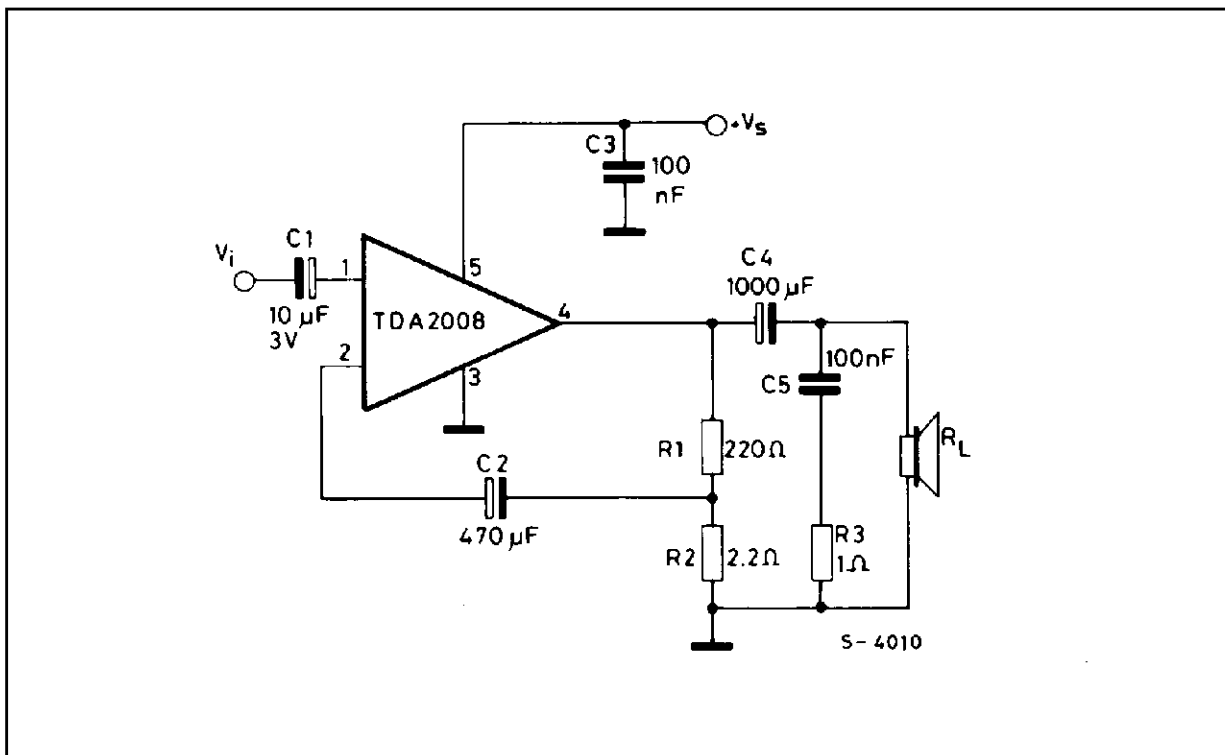

THERMAL DATA

Symbol	Parameter	Value	Unit
R _{th-j-case}	Thermal resistance junction-case max	3	°C/W

ELECTRICAL CHARACTERISTICS (Refer to the test circuit, V_s = 18V, T_{amb} = 25 °C unless otherwise specified)

Symbol	Parameter	Test conditions	Min.	Typ.	Max.	Unit	
V _s	Supply voltage		10		28	V	
V _o	Quiescent output voltage (pin 4)			10.5		V	
I _d	Quiescent drain current (pin 5)			65	115	mA	
P _o	Output power	d = 10% f = 1 KHz	R _L = 8Ω		8		W
			R _L = 4Ω	10	12		W
V _i (RMS)	Input saturation voltage		300			mV	
V _i	Input sensitivity	f = 1 KHz					
		P _o = 0.5W	R _L = 8Ω		20		mV
		P _o = 8W	R _L = 8Ω		80		mV
		P _o = 0.5W	R _L = 4Ω		14		mV
		P _o = 12W	R _L = 4Ω		70		mV
B	Frequency response (-3 dB)	P _o = 1W R _L = 4Ω	40 to 15,000			Hz	
d	Distortion	f = 1 KHz					
		P _o = 0.05 to 4W P _o = 0.05 to 6W	R _L = 8Ω R _L = 4Ω		0.12 0.12	1 1	% %
R _i	Input resistance (pin 1)	f = 1 KHz	70	150		KΩ	
G _v	Voltage gain (open loop)	f = 1 KHz R _L = 8Ω		80		dB	
G _v	Voltage gain (closed loop)		39.5	40	40.5	dB	
e _N	Input noise voltage	BW = 22Hz to 22 KHz		1	5	μV	
i _N	Input noise current			60	200	pA	
SVR	Supply voltage rejection	V _{ripple} = 0.5 R _g = 10KΩ R _L = 4Ω	f = 100 Hz	30	36		dB

APPLICATION INFORMATION

Figure 1. Typical application circuit

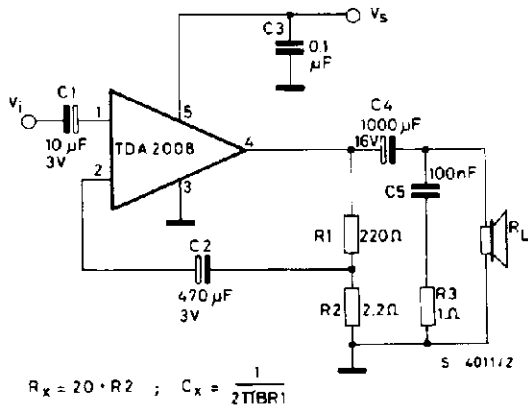

Figure 2. P.C. board and component layout for the circuit of fig. 1 (1:1 scale)

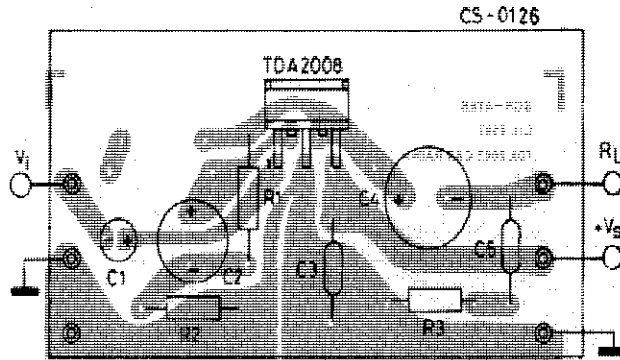

Figure 3. 25W bridge configuration application circuit (°)

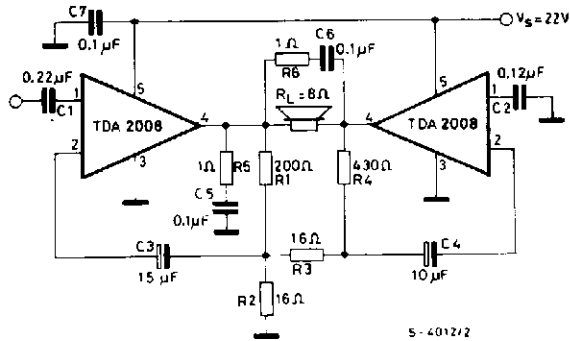
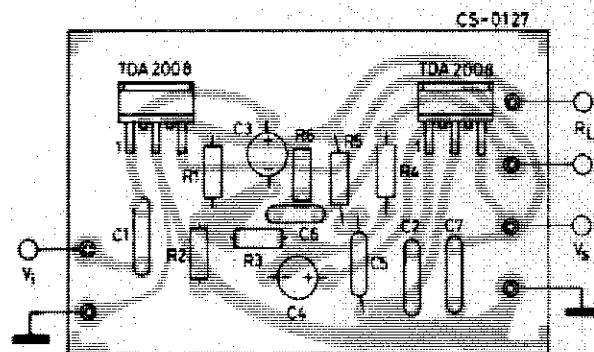

Figure 4. P.C. board and component layout for the circuit of fig. 3 (1:1 scale)



(°) The value of the capacitor C3 and C4 are different to optimize the SVR (Typ. = 40 dB)

Figure 5. Quiescent current vs. supply voltage

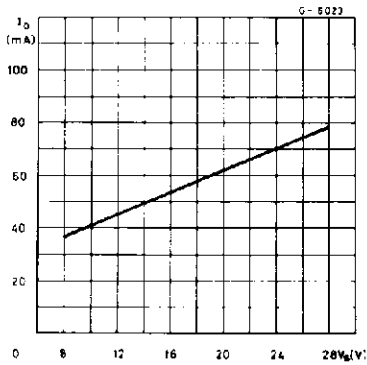

Figure 6. Output voltage vs. supply voltage

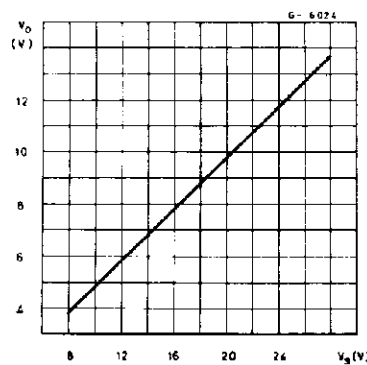

Figure 7. Output power vs. supply voltage

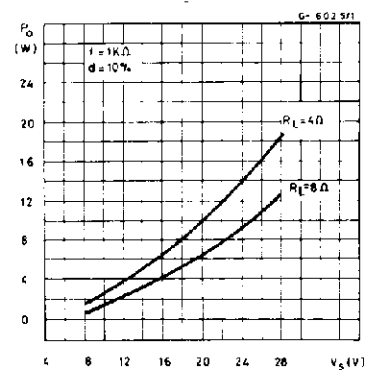

Figure 8. Distortion vs. frequency

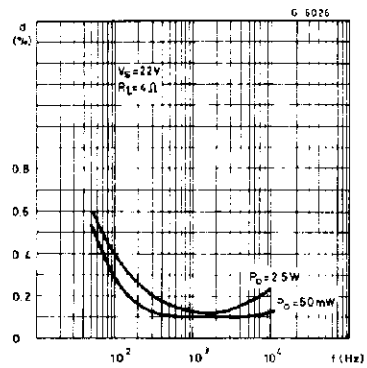

Figure 9. Supply voltage rejection vs. frequency

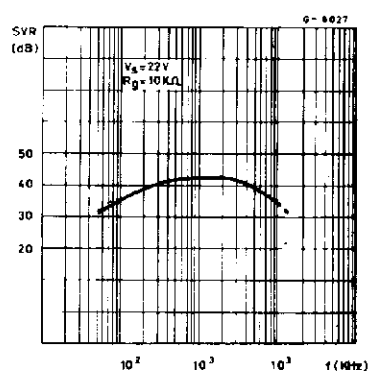
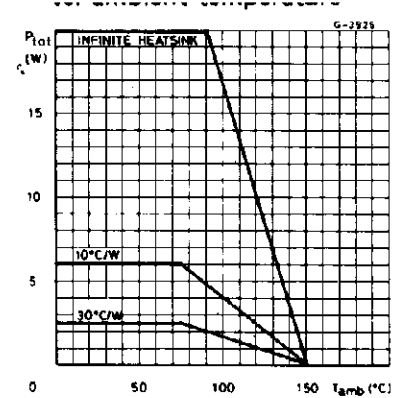

Figure 10. Maximum allowable power dissipation vs. ambient temperature



PRACTICAL CONSIDERATIONS

Printed circuit board

The layout shown in Fig. 2 is recommended. If different layouts are used, the ground points of input 1 and input 2 must be well decoupled from the ground of the output through which a rather high current flows.

Assembly suggestion

No electrical insulation is needed between the

package and the heat-sink. Pin length should be as short as possible. The soldering temperature must not exceed 260°C for 12 seconds.

Application suggestions

The recommended component values are those shown in the application circuits of Fig. 1. Different values can be used. The following table is intended to aid the car-radio designer.

Component	Recommended value	Purpose	Larger than recommended value	Smaller than recommended value
C1	2.2 μ F	Input DC decoupling		Noise at switch-on, switch-off
C2	470 μ F	Ripple rejection.		Degradation of SVR.
C3	0.1 μ F	Supply by passing.		Danger of oscillation.
C4	1000 μ F	Output coupling.		Higher low frequency cutoff.
C5	0.1 μ F	Frequency stability.		Danger of oscillation at high frequencies with inductive loads.
R1	$(G_v - 1) \cdot R_2$	Setting of gain. (*)		Increase of drain current.
R2	2.2 Ω	Setting of gain and SVR.	Degradation of SVR.	
R3	1 Ω	Frequency stability.	Danger of oscillation at high frequencies with inductive loads.	

(*) The closed loop gain must be higher than 26dB.

PENTAWATT PACKAGE MECHANICAL DATA

DIM.	mm			inch		
	MIN.	TYP.	MAX.	MIN.	TYP.	MAX.
A			4.8			0.189
C			1.37			0.054
D	2.4		2.8	0.094		0.110
D1	1.2		1.35	0.047		0.053
E	0.35		0.55	0.014		0.022
F	0.8		1.05	0.031		0.041
F1	1		1.4	0.039		0.055
G		3.4		0.126	0.134	0.142
G1		6.8		0.260	0.268	0.276
H2			10.4			0.409
H3	10.05		10.4	0.396		0.409
L		17.85			0.703	
L1		15.75			0.620	
L2		21.4			0.843	
L3		22.5			0.886	
L5	2.6		3	0.102		0.118
L6	15.1		15.8	0.594		0.622
L7	6		6.6	0.236		0.260
M		4.5			0.177	
M1		4			0.157	
Dia	3.65		3.85	0.144		0.152

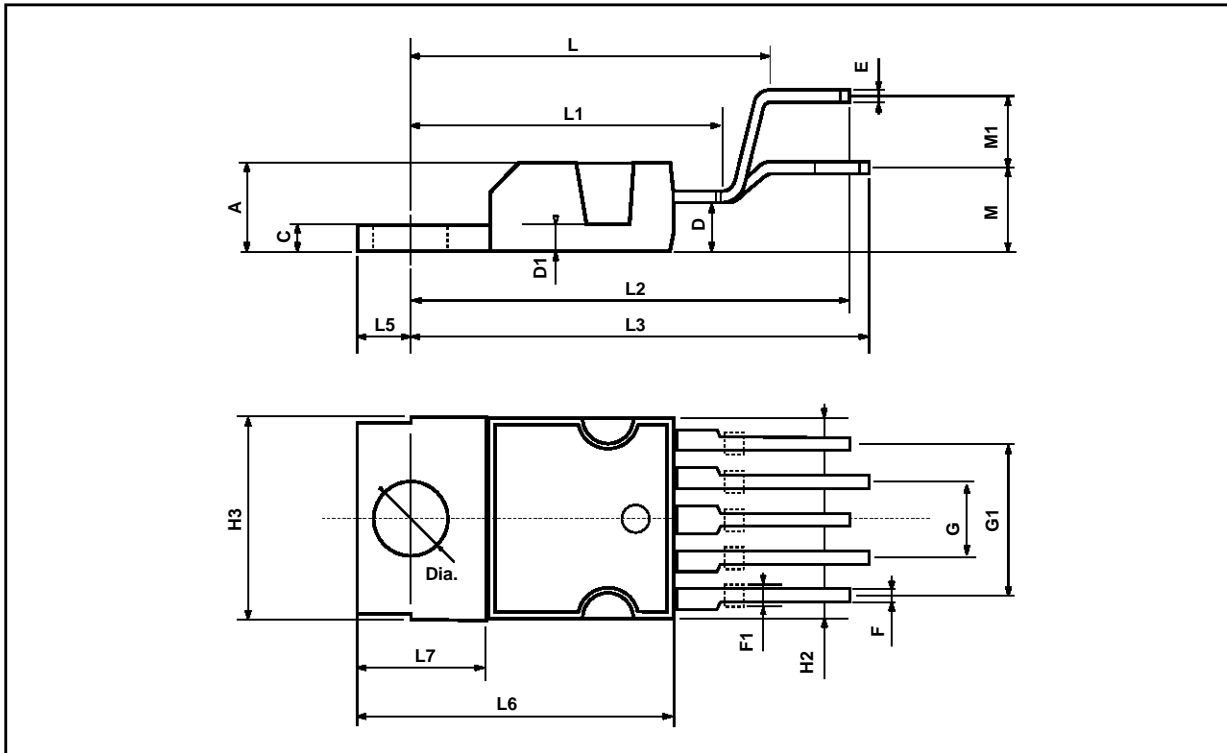

Information furnished is believed to be accurate and reliable. However, SGS-THOMSON Microelectronics assumes no responsibility for the consequences of use of such information nor for any infringement of patents or other rights of third parties which may result from its use. No license is granted by implication or otherwise under any patent or patent rights of SGS-THOMSON Microelectronics. Specifications mentioned in this publication are subject to change without notice. This publication supersedes and replaces all information previously supplied. SGS-THOMSON Microelectronics products are not authorized for use as critical components in life support devices or systems without express written approval of SGS-THOMSON Microelectronics.

© 1994 SGS-THOMSON Microelectronics - All Rights Reserved

SGS-THOMSON Microelectronics GROUP OF COMPANIES

Australia - Brazil - France - Germany - Hong Kong - Italy - Japan - Korea - Malaysia - Malta - Morocco - The Netherlands - Singapore - Spain - Sweden - Switzerland - Taiwan - Thailand - United Kingdom - U.S.A.