

TV AND SATELLITE DECODER SCANNING PROCESSOR

- AUTOMATIC TIME CONSTANT SWITCHING FOR VCR
- DIGITAL VIDEO IDENTIFICATION CIRCUIT
- 500kHz RESONATOR OSCILLATOR
- NO LINE AND FRAME OSCILLATOR ADJUSTMENT
- DUAL PLL FOR LINE DEFLECTION
- SUPER SANDCASTLE OUTPUT
- AUTOMATIC 50Hz/60Hz STANDARD IDENTIFICATION
- EXCELLENT INTERLACING CONTROL
- FRAME SAFETY INPUT
- FRAME SAWTOOTH GENERATOR
- FULLY ESD AND LATCH-UP PROTECTED

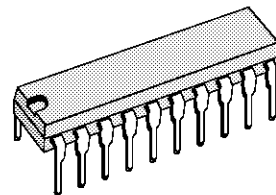

DIP20
(Plastic Package)

ORDER CODE : TEA2130

DESCRIPTION

The TEA2130 is a complete (horizontal and vertical) deflection processor, for TV applications and all applications which require a flexible, high performance scanning processor (Satellite Decoder, Video Multimedia).

PIN CONNECTIONS

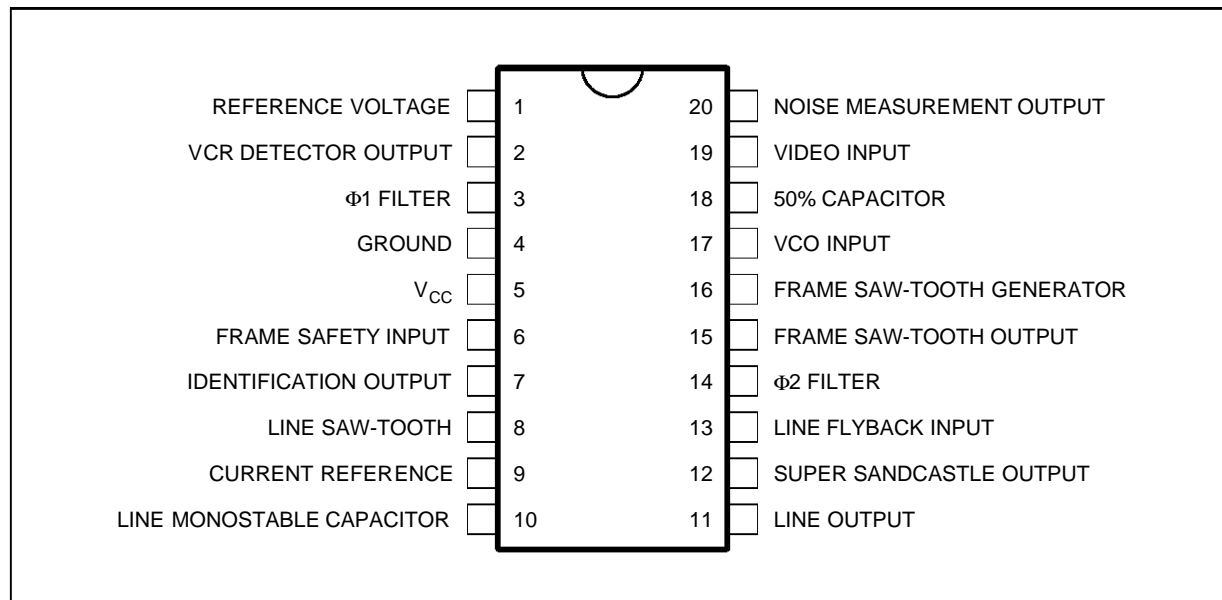

213001.EPS

BLOCK DIAGRAM

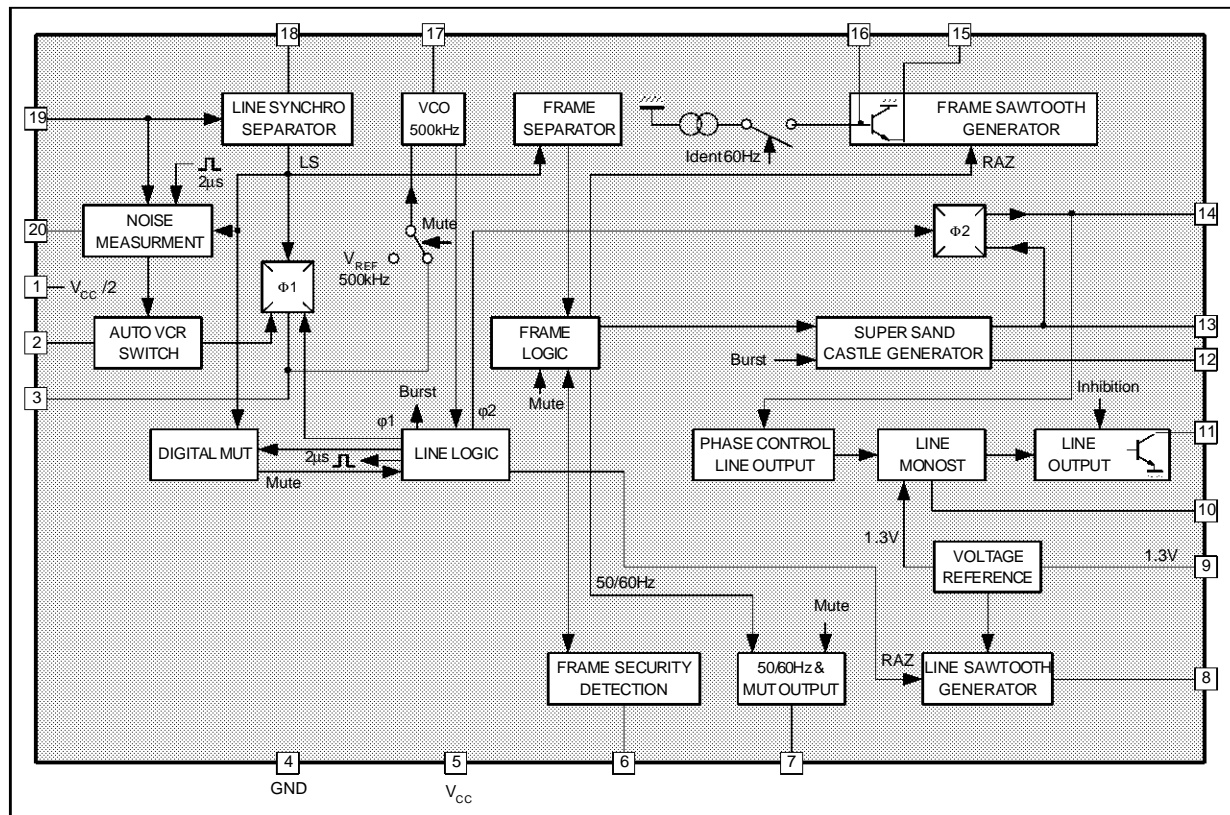

GENERAL DESCRIPTION

Introduction

This integrated circuit uses high density I2L bipolar technology and combines analog signal processing with digital processing.

Timing signals are obtained from a voltage-controlled oscillator (VCO) operating at 500kHz by means of a cheap ceramic resonator. This avoids the frequency adjustment normally required with line and frame oscillators.

A chain of dividers and appropriate logic circuitry produces very accurate defined sampling pulses and the necessary timing signals.

Internal Functions

- Horizontal scanning processor
- Frame scanning processor
- B class frame output stage using an external power amplifier with flyback generator
- Line and frame synchronization separation
- Dual phase-locked loop horizontal scanning
- High performance frame and line synchronization with interlacing control.

- Supersandcastle generator with reduced burst gate pulse for 60Hz
- Automatic 50Hz / 60Hz standard identification
- Frame saw-tooth generator
- Digital video identification circuit
- Very steady free running mode of the line and frame oscillator when no video is detected. This allows on screen display without phase jitter in research mode of the tuner
- Automatic VCR mode recognition for time constant switching
- Frame safety input

WORKING DESCRIPTION

Synchronization Separator

Line synchronization separator is clamped to black level of input video signal with synchronization pulse bottom level measurement.

The synchronization pulses are divided centrally between the black level and the synchronization pulse bottom level, to improve performance on video signal in noise conditions.

Frame Synchronization

Frame synchronization is fully integrated (no external capacitor required).

The frame timing identification logic permits automatic adaptation to 50-60Hz standards or non-interlaced video.

An automatic synchronization window width system provides:

- Fast frame capture (7.3ms wide window)
- Good noise immunity (0.4ms narrow window)

The internal generator starts the discharge of the sawtooth generator capacitor, so that it is not disturbed by line flyback effects.

Thanks to the logic control, the beginning of the charge phase does not depend on any disturbing effect of the line flyback. A 32 μ s timing is automatically applied on standardized transmissions for perfect interlacing.

In VCR mode, the discharge time is controlled by an internal monostable independent of the line frequency and gives a direct frame synchronization.

Horizontal Scanning

The horizontal scanning frequency is obtained from the 500kHz VCO.

The circuit uses two PLL:

- The first one controls the frequency
- The second one controls the relative phase of the output line pulse and the line flyback signals.

The output pulse has a constant duration of 29 μ s, independent of V_{CC} and of any delay in switching-off the scanning transistor.

Supersandcastle Generator

This output delivers a 3 level synchronization signal:

- Burst level
- Line blanking level
- Frame blanking level

In the event of vertical scanning failure, the frame blanking level goes high to protect the tube.

Frame Scanning

The current to charge the frame sawtooth generator is automatically switched to 60Hz operation to maintain constant amplitude.

Automatic VCR Mode Recognition for Time Constant Switching

- A third phase comparator is used to detect VCR signals and to switch the $\phi 1$ short time constant.
- A noise level measurement is realized on the video synchronization pulse to inhibit the short time constant if the noise level is superior to an adjustable threshold.
- VCR signals are detected if peak to peak signal on pin 2 is superior to an internal threshold.

This threshold is depending on the noise level. So with a no noisy video signal, the auto VCR switch sensitivity is maximum, and it decreases when the noise increases.

- The sensitivity of the noise gate and the auto VCR switch is adjustable by external resistance.
- Long and short time constants can be selected manually by Pin 20.

Digital Video Identification

A digital circuit controls the identification signal. When identification signal is low, the line oscillator is set on a reference frequency. When identification signal is high, $\phi 1$ is locked and the catching phase can start. So that, the TEA2130 allowed on screen displays in a steady way even without video signal (during tuner research for example).

Identification Output

The identification function provides three different levels :

- 0V : No video identification
- 6V : 60Hz video identification
- 12V : 50Hz video identification

This information may be used for timing research in the case of frequency or voltage synthesizer type receivers and for audio muting.

ABSOLUTE MAXIMUM RATINGS

Symbol	Parameter	Value	Unit
V_{CC}	Supply Voltage	13.5	V
V_{16}	Pulse/Frame Sawtooth Generator Voltage	$V_{CC} - 3$	V
I_{11}	Output Current	40	mA
I_{13}	Input Current	± 5	mA
T_{AMB}	Operating Ambient Temperature	0 , + 70	$^{\circ}$ C

THERMAL DATA

Symbol	Parameter	Value	Unit
$R_{th(j-a)}$	Junction-ambient Thermal Resistance	80	$^{\circ}$ C/W

TEA2130

ELECTRICAL CHARACTERISTICS ($T_{amb} = 25^{\circ}\text{C}$; $V_{CC} = 12\text{V}$; Pulse duration 50% of the amplitude)

Symbol	Parameter	Test conditions	Min.	Typ.	Max.	Unit
	Supply Voltage			12		V
	Supply Current	Without load in pins 7-12-15	20	29	40	mA
	V_{CC} Starting Voltage for Line Output	V_{CC} rising		7	7.5	V
	Switch-off Voltage for Line Output	V_{CC} decreasing		6.5		V

VIDEO INPUT (Pin 19)

	Video Signal Amplitude	Z source < 220Ω	0.2	1	3	V_{PP}
	Push out Current	During the synch. pulse	- 40	- 32	- 24	μA
	Pull in Current	During the line	3	5	7	μA

50% SYNCH. PULSE CLAMP (Pin 18)

	Push out Current	During the synch. pulse	- 960	- 350	- 40	μA
	Pull in Current	During the line	15	23	32	μA

$\phi 1$ AND $\phi 3$ COMPARATOR (Pin 2- Pin 3)

	Short Time Output Current	Identification high	± 1.1	± 1.5	± 2	mA
	Long Time Output Current	Identification high	± 0.30	± 0.48	± 0.65	mA

VCO (Pin 17)

	Catching Range	Ceramic CSB 503B $R_{SERIAL} = 470\Omega$	15.40		15.92	kHz
	Transfer Characteristic	ΔF pin 11/ ΔV pin 3		2		kHz/V
	Free Running Frequency	Without video signal	15.6	15.9	16.2	kHz

VIDEO IDENTIFICATION AND STANDARD OUTPUT (Pin 7)

	No video on Pin 19	$R_{LOAD}/GND = 5k\Omega$		0	500	mV
	60Hz video		5.5	6	6.5	V
	50Hz video		10.5	11.3		V

REFERENCE VOLTAGE (Pin 1)

	Output voltage	$I_1 = 0$	5.5	6	6.5	V
	Output impedance	$\Delta I_1 = \pm 50\mu\text{A}$	400	600	800	Ω
	Max output current				200	μA

AUTO VCR SWITCH (Pin 2)

	V Switching threshold / V_1 Short time ct2 on $\phi 1$ PM Active above Threshold	<ul style="list-style-type: none"> With no noise on the video ($V_{20} < 6\text{V}$) With noise on video ($6\text{V} < V_{20} < 7.3\text{V}$) 	± 0.2	± 0.3	± 0.4	V
			0.69 x V_{20} - 3.85			V

NOISE GATE (Pin 20)

	Measure sampling time	On the synch. pulse bottom	1	2	3	μs
	Max. push out current	$V_{noise} = 0.4V_{PP}$, $F = 1\text{MHz}$ on $2V_{PP}$ Video Signal		350		μA
	VCR mode inhibition threshold (long time cte)	Active above threshold Voltage hysteresis	6.9	7.3 100	7.5	V mV
	Measure bandwidth (-3dB)	High cut frequency Low cut frequency		2 0.7		MHz MHz
	Short time constant manual switching threshold	Active under threshold	4.5	5	5.5	V

2130-03.TBL

ELECTRICAL CHARACTERISTICS (continued)(T_{amb} = 25°C; V_{CC} = 12V; Pulse duration 50% of the amplitude)

Symbol	Parameter	Test conditions	Min.	Typ.	Max.	Unit
--------	-----------	-----------------	------	------	------	------

 ϕ 2 COMPARATOR (Pin 14)

	Output current	During line flyback	± 300	± 500	± 700	μA
	Delay between ϕ 2 falling edge and the middle video sync. pulse	F _{VCO} = 500 kHz	2.2	2.7	3.2	μs

LINE MONOSTABLE (Pin 10)

	Charge current	Line output high		- 67		μA
	Discharge current	Line output low		170		μA
	Flip-Flop threshold	Falling edge on the line output		1.3		V

LINE OUTPUT (Pin 11)

	Low level	I ₁₁ = 20 mA			1	V
	Pulse duration	R ₉ = 3.32k Ω , C ₁₀ = 1.5nF	27	29.5	32	μs
	ϕ 2 adjustment range	Controlled by V ₁₄ compared with video signal	15	18		μs

LINE SAW-TOOTH (Pin 8)

	Charge Current	R ₉ = 3.32 k Ω	- 200	- 180	- 150	μA
	Discharge Current		3.5	7		mA
	Discharge Duration	Controlled by logic VCO 500kHz		6.5		μs

LINE FLYBACK INPUT (Pin 13)

	Blanking Line Threshold	Active above threshold	0.35	0.4	0.6	V
	ϕ 2 Loop Threshold and Line Output Inhibition (Pin 11)	Active above threshold	2.7	3	3.3	V
	Input Current	- 0.4V < V ₁₃ < 0.4V 0.4V < V ₁₃ < 3V 3V < V ₁₃	- 20 - 10	-10 - 5	- 4 - 4 - 1	μA μA μA

SUPER SANDCASTLE GENERATOR (Pin 12)

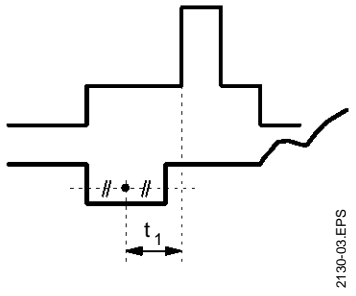
	Burst Level	R _L = 2.2 k Ω to ground	9			V
	Line Blanking Level		4	4.5	5	V
	Frame Blanking Level		2	2.5	3	V
	Delay between the middle of the video sync. pulse and the rising edge of the burst (t ₁)		2.45	2.8	3.15	μs
	Burst Pulse Duration	• 50Hz • 60Hz	4.1 3.6	4.4 3.9	4.7 4.2	μs μs
	Line Blanking Duration	Fixed by flyback Signal pin 13				
	Frame Blanking Duration	Fixed by the logic		21		Line

2130-04.TBL

TEA2130

ELECTRICAL CHARACTERISTICS (continued)

$T_{amb} = 25^{\circ}\text{C}$; $V_{CC} = 12\text{V}$; Pulse duration 50% of the amplitude

Symbol	Parameter	Test conditions	Min.	Typ.	Max.	Unit
--------	-----------	-----------------	------	------	------	------

FRAME SAW-TOOTH GENERATOR

	Low DC Voltage		1.1	1.3	1.45	V
	Discharge Current		15		60	mA
	60Hz Internal Current		- 10	- 8	- 6	μA

FRAME LOGIC SYNCH.

	Free Running Period	Without video signal		315		Line
	Synchronization Windows	Identification low	247		361	Line
		Identification 60Hz high	247		277	Line
		VCR mode	247		361	Line

CURRENT REFERENCE (Pin 9)

	V_9 Voltage	$R_9 = 3.32 \text{ k}\Omega$ (1%)	1.2	1.3	1.4	V
	Max. Temperature Shift	$\Delta T = 80^{\circ}\text{C}$		± 1		%

FRAME SAFETY INPUT (Pin 6)

	Switching Threshold	Activated without negative pulse during frame blanking time for permanent frame blanking on SSC output Pin 12		1.3		V
	Output current		- 35	- 50	- 67	μA

2130-05.TBL

TYPICAL TV APPLICATION

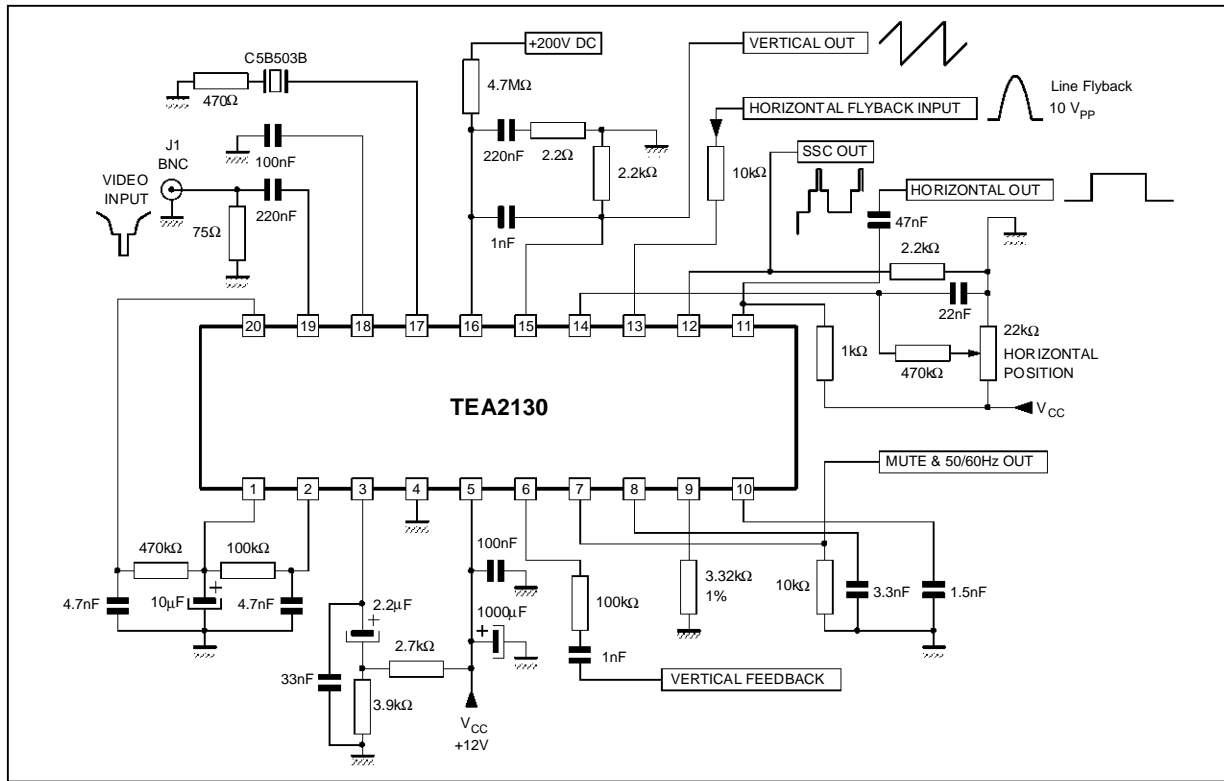

2130-04.EPS

TYPICAL SYNC SEPARATOR APPLICATION

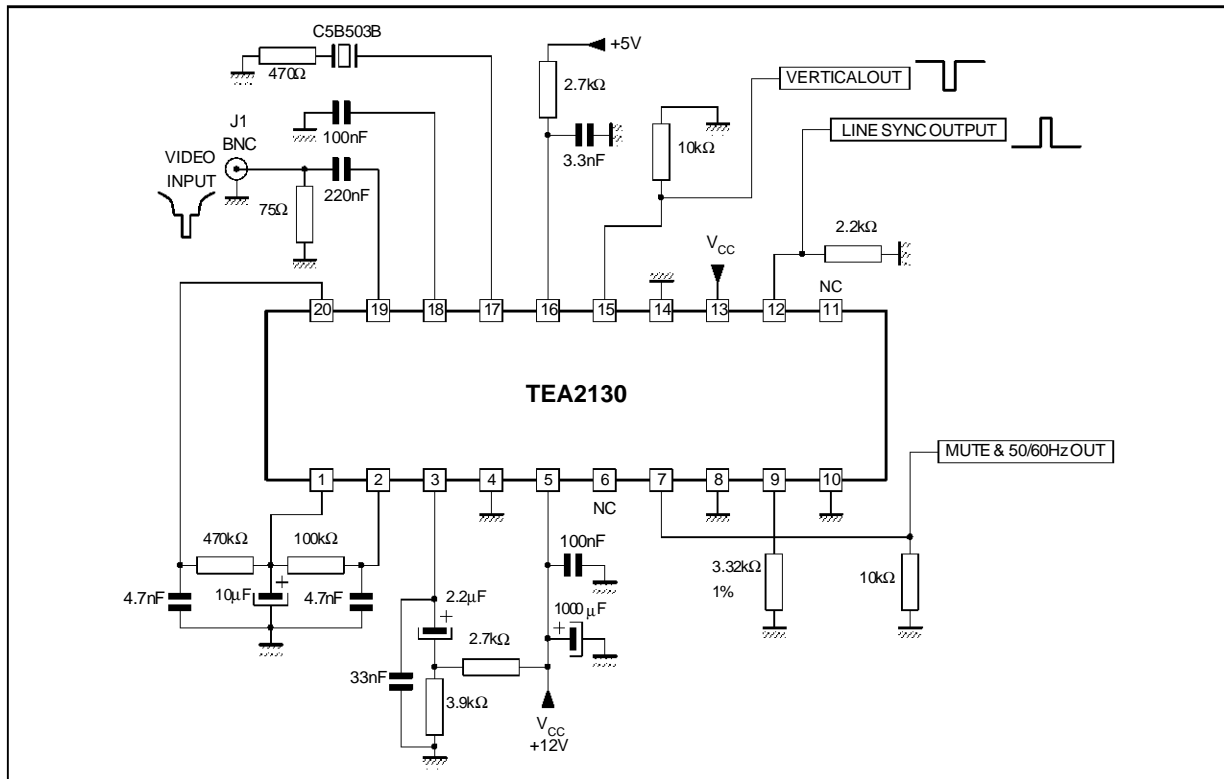

2130-05.EPS

TEA2130

PACKAGE MECHANICAL DATA

20 pins - PLASTIC DIP

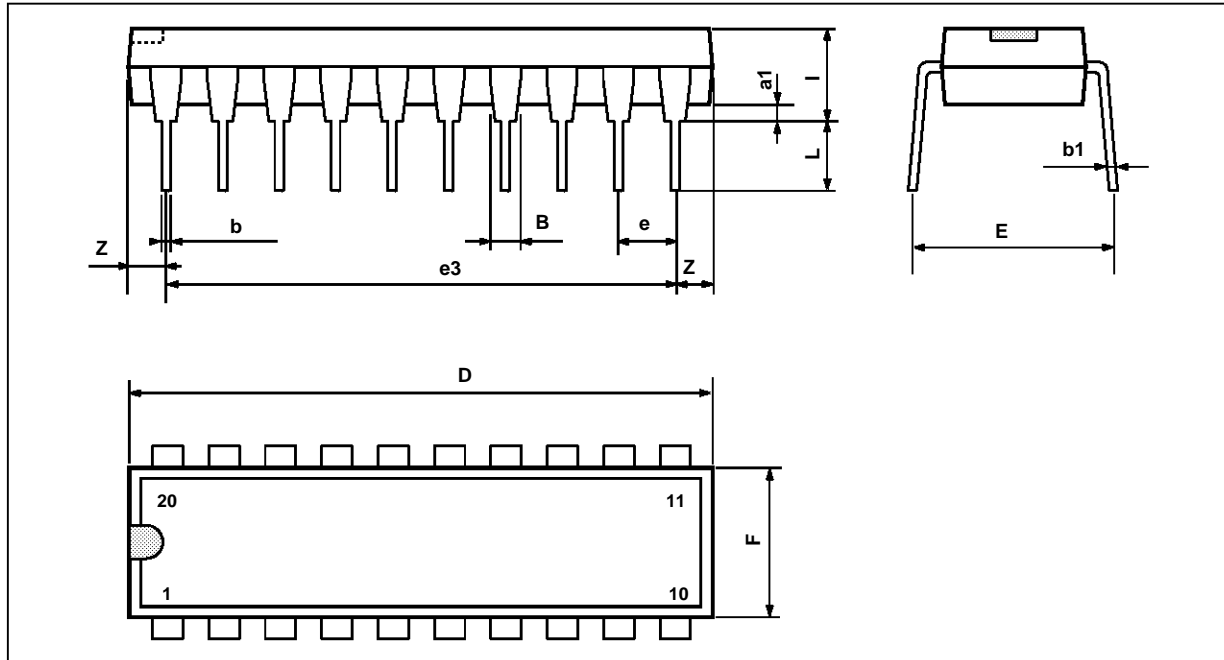

PM-DIP20.EPS

Dimensions	Millimeters			Inches		
	Min.	Typ.	Max.	Min.	Typ.	Max.
a1	0.254			0.010		
B	1.39		1.65	0.055		0.065
b		0.45			0.018	
b1		0.25			0.010	
D			25.4			1.000
E		8.5			0.335	
e		2.54			0.100	
e3		22.86			0.900	
F			7.1			0.280
i			3.93			0.155
L		3.3			0.130	
Z			1.34			0.053

DIP20.TBL

Information furnished is believed to be accurate and reliable. However, SGS-THOMSON Microelectronics assumes no responsibility for the consequences of use of such information nor for any infringement of patents or other rights of third parties which may result from its use. No licence is granted by implication or otherwise under any patent or patent rights of SGS-THOMSON Microelectronics. Specifications mentioned in this publication are subject to change without notice. This publication supersedes and replaces all information previously supplied. SGS-THOMSON Microelectronics products are not authorized for use as critical components in life support devices or systems without express written approval of SGS-THOMSON Microelectronics.

© 1994 SGS-THOMSON Microelectronics - All Rights Reserved

Purchase of I²C Components of SGS-THOMSON Microelectronics, conveys a license under the Philips I²C Patent. Rights to use these components in a I²C system, is granted provided that the system conforms to the I²C Standard Specifications as defined by Philips.

SGS-THOMSON Microelectronics GROUP OF COMPANIES

Australia - Brazil - China - France - Germany - Hong Kong - Italy - Japan - Korea - Malaysia - Malta - Morocco
The Netherlands - Singapore - Spain - Sweden - Switzerland - Taiwan - Thailand - United Kingdom - U.S.A.