

VIF/SIF SYSTEM FOR COLOR TV

The KA2919 is a silicon monolithic integrated circuit containing the VIF section and SIF section on a single chip in the shrink-type 30SDIP package. Since the KA2919 is capable of performing video detection and sound detection independently or simultaneously, it can be applied to various sets from popular types to high-grade types, according to the designer's policy.

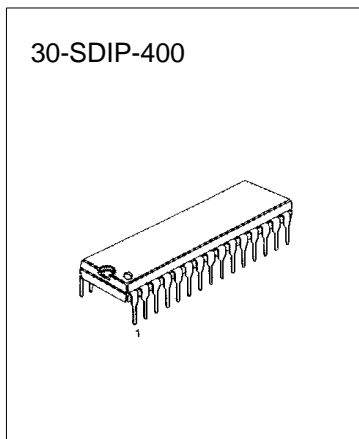

FUNCTIONS

VIF

- VIF Amp
- Video Det
- Peak IFAGC
- B/W Noise Canceller,
- RF AGC
- AFT
- SIF Det

SIF

- SIF Limiter Amp
- FM Det
- DC ATT
- AF Driver

ORDERING INFORMATION

Device	Package	Operating Temperature
KA2919	30-SDIP-400	-20°C ~+70°C

FEATURES

- High-Gain VIF amp requiring no preamp
- High AGC speed
- Provides wide-band detection characteristic and meets sound MPX demodulation requirements because of FM detection is quadrature detection
- Possible to use sound REC pin (Pin 2), AUX pin (Pin 3)
- Possible to mute video, sound for VTR Pin 7 GND: Muting of both video and sound
Pin 29 GND: Muting of sound only

BLOCK DIAGRAM

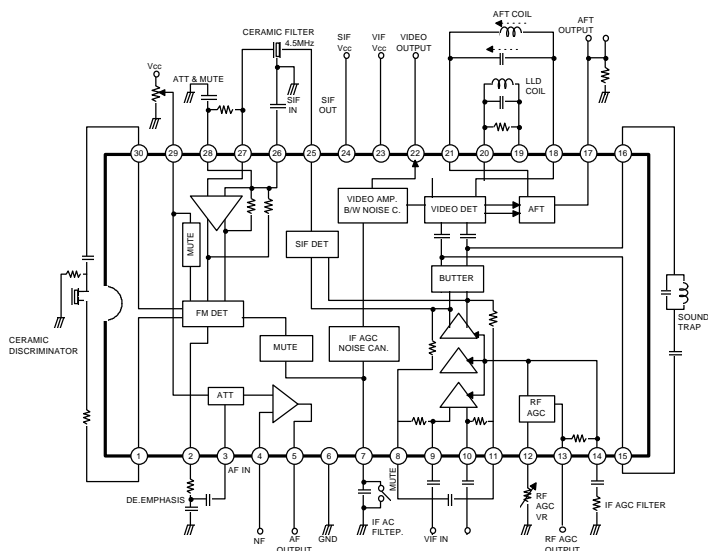

ELECTRICAL CHARACTERISTICS

VIF SECTION ($T_A = 25^\circ\text{C}$, $V_{CC} = 12\text{V}$, $f_P = 45.75\text{MHz}$, $f_S = 41.25\text{MHz}$ (VIF), $f_O = 4.5\text{MHz}$ (SIF))

Characteristics	Symbol	Test Condition	Min	Typ	Max	Unit	Test FIG.
Total Circuit Current	$I_{23}+I_{24}$	DC	59	74	98	mA	1
Maximum RF AGC Voltage	V_{13H}	DC	8.5	8.9	9.2	V	1
Minimum RF AGC Voltage	V_{13L}	DC		0	0.5	V	1
Quiescent Video Output Voltage	V_{22}	DC	5.6	6.1	6.6	V	1
Quiescent AFT Output Voltage	V_{17}	DC	4.5	6.5	7.5	V	1
Input Sensitivity	S_{VI}	$f_m = 400\text{Hz}$ 40% AM, $V_O = 0.8V_{PP}$	30	36	42	dB μ	2
AGC Range	V_{AGC}	$f_m = 15\text{KHz}$ 78% AM, $V_O = \pm 1\text{dB}$	60	74		dB	2
Maximum Allowable Input	V_{MAX}	$f_m = 15\text{KHz}$ 78% AM, $V_O = \pm 1\text{dB}$	100	500		mV _{rms}	2
Video Output Amplitude	$V_{O(22)}$	$V_I = 10\text{mV}_{rms}$, $f_M = 15\text{KHz}$ 78% AM	1.9	2.2	2.5	V _{P-P}	2
Output S/N	S/N	$V_I = 10\text{mV}_{rms}$ CW	48	54		dB	2
Carrier Leakage	CL	$V_I = 100\text{mV}_{rms}$, $f_M = 15\text{KHz}$ 78% AM	50	57		dB	2
Maximum AFT Voltage	V_{17H}	$V_I = 10\text{mV}_{rms}$ SWEEP	11	11.5	12.0	V	2
Maximum AFT Voltage	V_{17L}	$V_I = 10\text{mV}_{rms}$ SWEEP	0	0.4	1.0	V	2
AFT Detection Sensitivity	S_f	$V_I = 10\text{mV}_{rms}$ SWEEP	70	100	140	mV/KHz	2
White Noise Threshold Level	V_{WTH}	$V_I = 10\text{mV}_{rms}$ SWEEP	6.4	6.8	7.2	V	2
White Noise Clamp Level	V_{WCL}	$V_I = 10\text{mV}_{rms}$ SWEEP	4.2	4.6	5.0	V	2
Black Noise Threshold Level	V_{BTH}	$V_I = 10\text{mV}_{rms}$ SWEEP	1.9	2.2	2.5	V	2
Black Noise Clamp Level	V_{BCL}	$V_I = 10\text{mV}_{rms}$ SWEEP	3.8	4.2	4.6	V	2
SIF Output Signal Voltage	$V_{O(25)}$	P/S = 20dB	40	60	100	mV _{rms}	2
Frequency Characteristic	f_C	-3dB	6	8		MHz	2
Differential Gain	DG	$V_I = 10\text{mV}_{rms}$ 87.5% VIDEOMOD		4	10	%	2
Differential Phase	DP	$V_I = 10\text{mV}_{rms}$ 87.5% VIDEOMOD		3	6	deg	2
Input Resistance	R_I		1.0	1.5	2.0	Kohm	2
Input Capacitance	C_I			3.5	7.0	pF	2

*Electronic Volume Control Characteristic

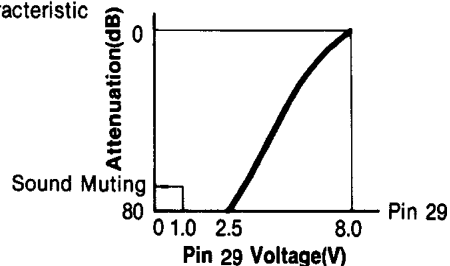

SIF SECTION ($T_A = 25^\circ\text{C}$, $V_{CC} = 12\text{V}$, $f_P = 45.75\text{MHz}$, $f_S = 41.25\text{MHz}$ (VIF), $f_O = 4.5\text{MHz}$ (SIF))

Characteristics	Symbol	Test Condition	Min	Typ	Max	Unit	Test FIG.
SIF Limiting Voltage	VI (LIM)	-3dB		200	400	μV_{rms}	2
Detection Output Voltage	V_O (2)	$V_I = 100\text{mV}_{\text{rms}}$, $f_m = 400\text{Hz}$, $f = \pm 25\text{KHz}$	450	680	850	mV_{rms}	2
Distortion	THD (2)	$V_I = 100\text{mV}_{\text{rms}}$, $f_m = 400\text{Hz}$, $f = \pm 25\text{KHz}$		0.5	1.0	%	2
AM Rejection	AMR	$V_I = 100\text{mV}_{\text{rms}}$, $f_m = 400\text{Hz}$, $f = \pm 25\text{KHz}$ 30% AM	50	60		dB	2
DCVR Maximum Attenuation	ATT	$V_I = 200\text{mV}_{\text{rms}}$, $f = 400\text{Hz}$	70	80		dB	2
AF Amp Gain	G_{AF}	$V_I = 100\text{mV}_{\text{rms}}$, $f = 400\text{Hz}$	18	20	22	dB	2
AF Amp Outpt Voltage	V_O (5)	V_O (5) THD = 10%, $f = 400\text{Hz}$	3	4		V_{rms}	2

TEST CIRCUIT

1. DC TEST

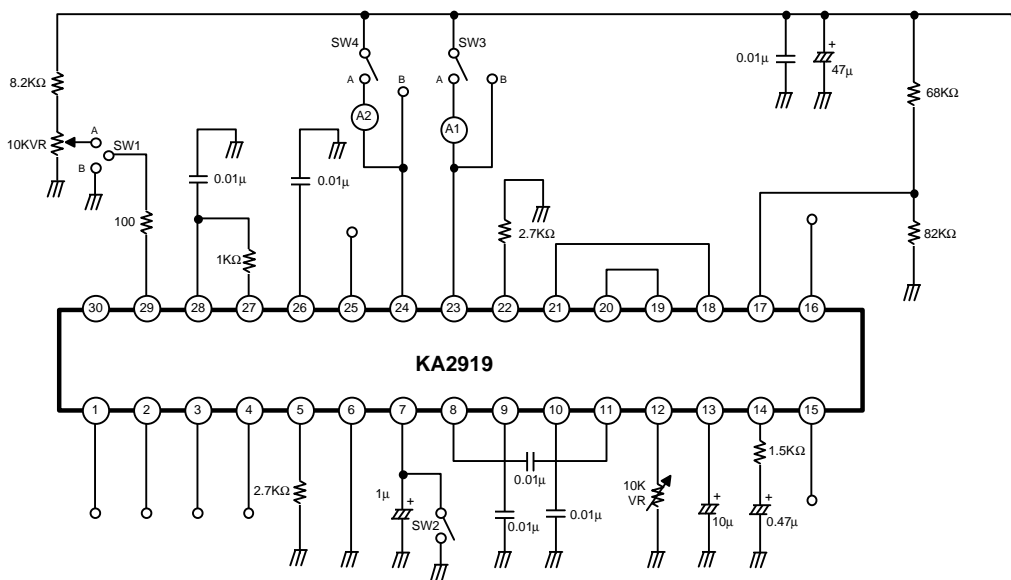

2. AC TEST

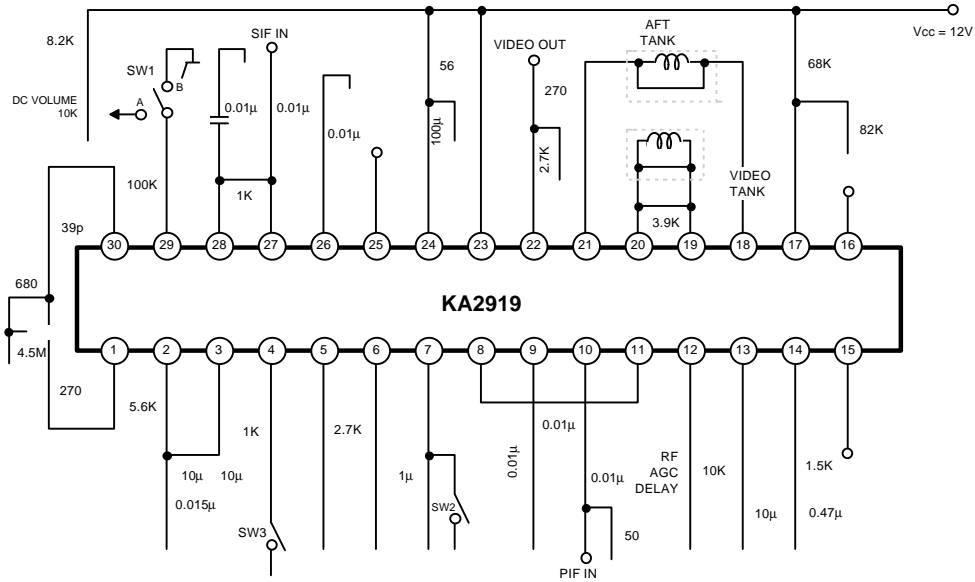

TYPICAL APPLICATION CIRCUIT

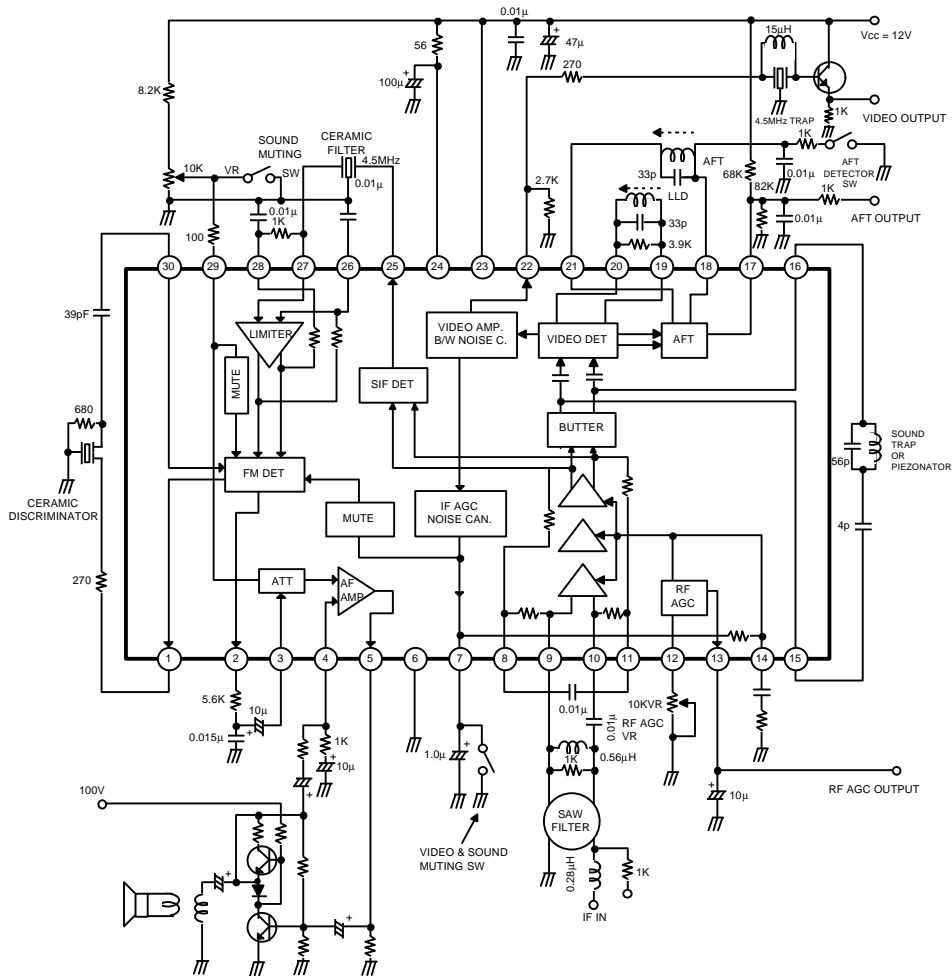



LittleDiode supplies new, hard to find or obsolete electronic components and semiconductors all over the world.

With over two million different components listed you are sure to find the part you need.

Feel free to visit us today at our online store:

LittleDiode.com

Looking forward to providing you with the best possible service.