

MONITOR AMPLIFIER

- PROGRAMMABLE GAIN IN STEPS OF 6 dB
- ON/OFF POSITION
- LOW VOLTAGE
- POWER : 100 mW AT 5 V

DESCRIPTION

This 16 pins IC is designed for monitor (loudspeaker) telephone set and provides :

- a) Signal amplification for monitoring (loudspeaker)
- b) Antiacoustic feedback (antilarsen)
- c) Antidistortion by automatic gain adaptation
- d) Antilarsen adjustment (full duplex)

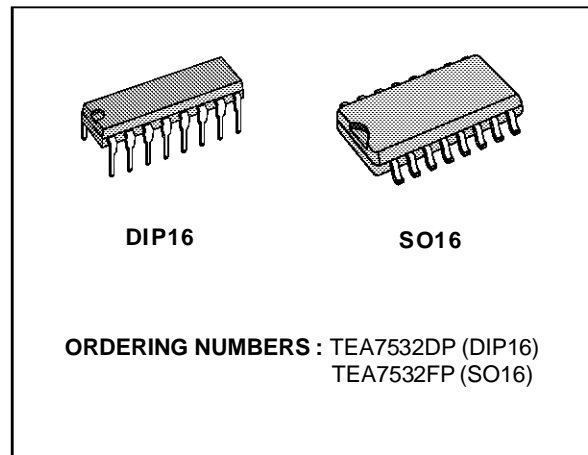

BLOCK DIAGRAM

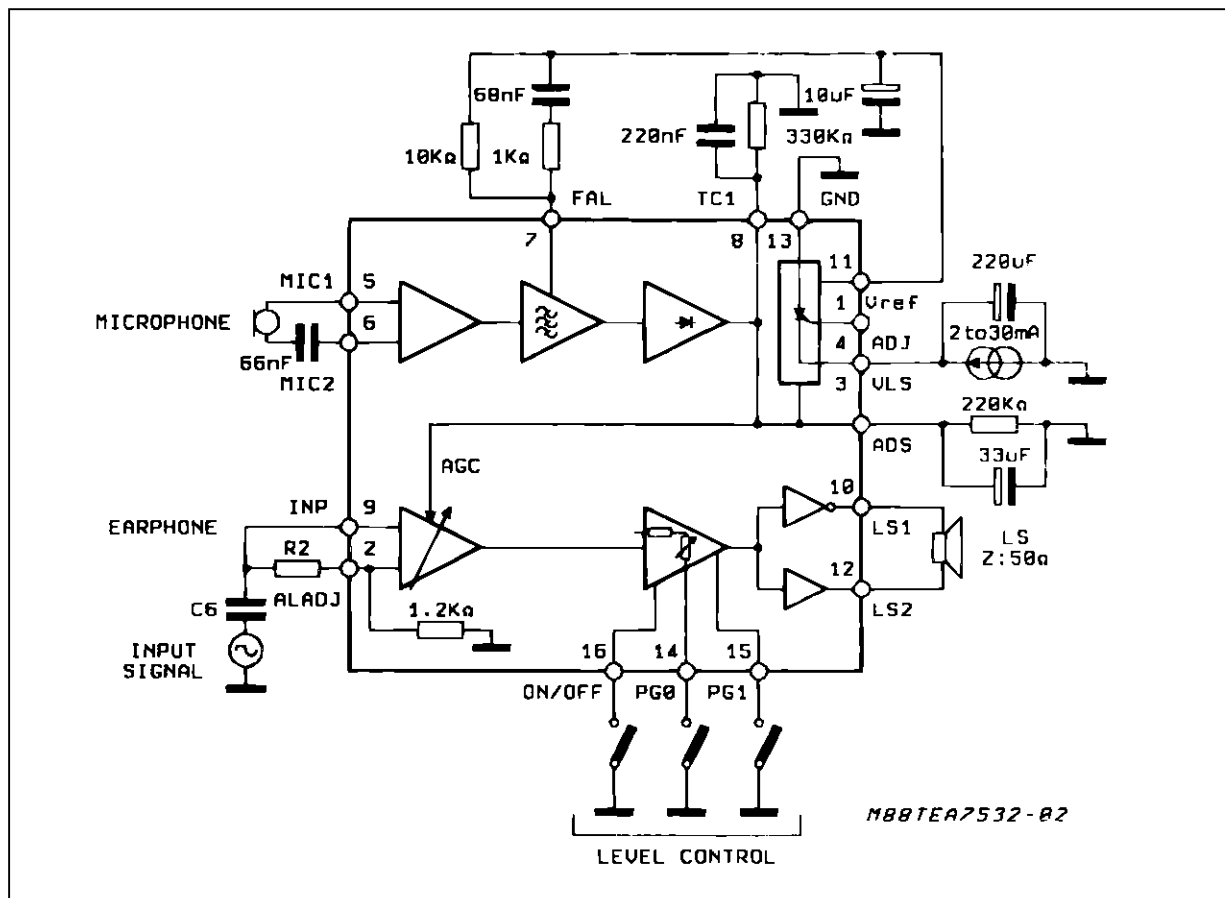

PIN CONNECTION (Top view)

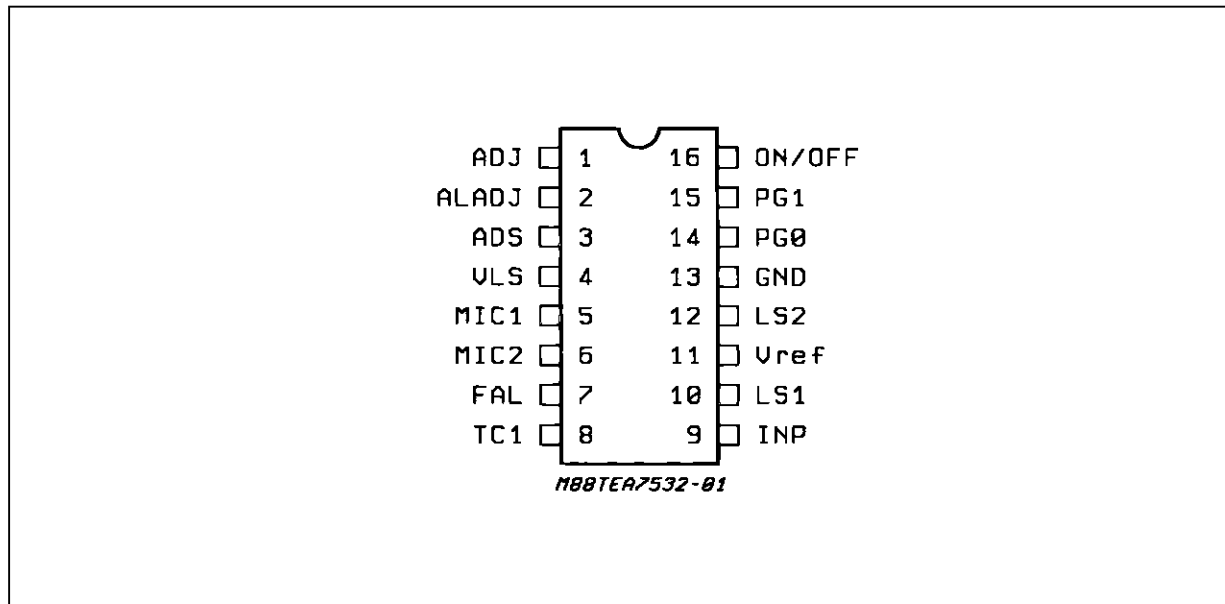

PIN DESCRIPTION

N°	Symbol	Description
1	ADJ	Adjust Internal Reference V_{LS}
2	ALADJ	Antilarsen Adjustement
3	ADS	Antidistortion
4	V_{LS}	Supply
5	MIC1	Microphone Input
6	MIC2	Microphone input
7	FAL	Antilarsen Filter
8	TC1	Antilarsen Time Constant
9	INP	Input Signal
10	LS1	Output Loudspeaker 1
11	V_{REF}	Internal Resistance
12	LS2	Output Loudspeaker 2
13	GND	Ground
14 15 16	PG0 PG1 ON/OFF	Inputs Program Level to Loudspeaker

ABSOLUTE MAXIMUM RATINGS

Symbol	Parameter	Value	Unit
T_{op}	Temperature Range	-5 to + 45	°C
V_{LS}	Supply Voltage	6	V
I_{LS}	Supply Current for $T > 300ms$ for $T \leq 300ms$	90 150	mA mA
V_L	Voltage Level (pins, PG0, PG1, on/off)	$0.6 > V_S + 0.6$	V

ELECTRICAL CHARACTERISTICS ($T_{amb} = 25^{\circ}\text{C}$, $I_{LS} = 30\text{mA}$ unless otherwise specified)

Symbol	Parameter	Test Conditions	Min.	Typ.	Max.	Unit		
V_{LS1}	V_{LS} Supply	$I_{LS} = 2\text{mA}$ (fig. 7)	2.6	3.0	3.4	V		
		$I_{LS} = 30\text{mA}$ (fig. 7)		3.15	3.4	V		
V_{LSM}	V_{LS} Maximum	$I_{pin 1} = 50\mu\text{A}$ (fig. 7 ; $S_o = \text{closed}$)			5.5	V		
V_{ADJ}	Voltage Pin 1	$I_{LS} = 2\text{mA}$ to 30mA (fig. 7)	1.1	1.25	1.4	V		
G G000 G001 G010 G011 G100	Loudspeaker Amplifier Gain = $\frac{V_{10} - V_{12}}{V_9}$	ON/OFF						
		PG0						
		PG1						
		GND	GND	GND	12	14	16	dB
		GND	GND	V_{LS}	18	20	22	dB
		GND	V_{LS}	GND	24	26	28	dB
GND	V_{LS}	V_{LS}	30	32	34	dB		
V_{LS}	X	X		-30	-20	dB		
THD	Distortion	$f = 300\text{Hz}$ to 2kHz , $V_{10} - V_{12} = 0.8V_{RMS}$, $G = G_{011}$, (fig. 8)			2	%		
G2	$[V(10) - V(12)]/V2$	$P_{G0} = P_{G1} = V_{LS}$, $V_8 = 0.8V$ (fig. 8)	30	32	34	dB		
Z_{MICIN}	Microphone Input	Symetrical at (pins 5-6) Asymetrical at (pin 6) fig. 9		4.5		k Ω		
Z_{INPIN}	Earphone Input	(fig. 9)	2.2	2.8	3.4	k Ω		
Z_{IN2}	Antilarson Adjustment Input		1	1.2	1.45	k Ω		
V_{OFFS}	Ouput Offset $[V(10) - V(12)]$	G011 ; (fig. 8)	-50		50	mV		
$I_{ON/OFF}$ I_{PG0} I_{PG1}	Input Current ON State	$V_{PG1} = 0V$; (fig. 8)	-10	-5		μA		
			-10	-5		μA		
			-10	-5		μA		
$I_{ON/OFF}$ I_{PG0} I_{PG1}	Input Current OFF State	$V_{PG1} = V_{LS}$; (fig. 8)			1	μA		
					1	μA		
					1	μA		
$V_{IL ON/OFF}$ $V_{IL PG0}$ $V_{IL PG1}$	Input Voltage ON State				0.45	V		
					0.45	V		
					0.45	V		
$V_{IH ON/OFF}$ $V_{IH PG0}$ $V_{IH PG1}$	Input Voltage OFF State		1.5			V		
			1.5			V		
			1.5			V		
G_{MIC}	Microphone Gain = $V_{(7)}/[V_{(5)} - V_{(6)}]$	$V_{MIC} = 10\text{mV}_{RMS}$, $f = 2\text{kHz}$ (fig. 10)	22.5	23.5	24.5	dB		
V_g	Voltage Pin 8		0.48	0.67	0.75	V		
G_{ATT}	Loudspeaker Attenuated Gain = $[V(10) - V(12)]/V(9)$	G011 ; $V_8 = 0.6V$; (fig. 10) G011 ; $V_8 = 0.4V$; (fig. 10)	20	-30	-20	dB		
				30		dB		

FUNCTIONAL DESCRIPTION

TEA7532 performs the following functions :
The circuit amplifies the incoming signal and feeds it to the loudspeaker. PG0 and PG1 inputs are used to set the loudspeaker gain in a range of 32dB to 14dB in 6dB steps.
The TEA7532 inputs (PG0, PG1, ON/OFF) permit the loudspeaker to be cut-off thus ensuring privacy of communication.

- The antilarson (antiacoustic feedback) system is incorporated.
- The maximum power available on a 50 Ω impedance loudspeaker is 25mW at 3 volts and 100mW at 5V.

Limit values for external components :
R3 min = 5 k Ω (R3 adjust VLS), R7 max = 390 k Ω ,
R6 min = R7/35
R max between pin 5 and 6 = 10k Ω + C min = 10nF.

Figure 1 : Loudspeaker Gain Versus Voltage on Pin (3) - (8) with Pin 2 Open.

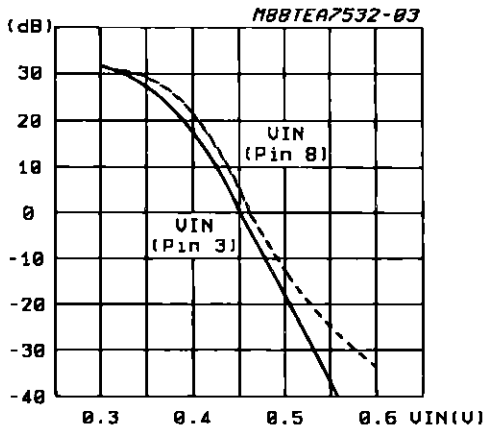
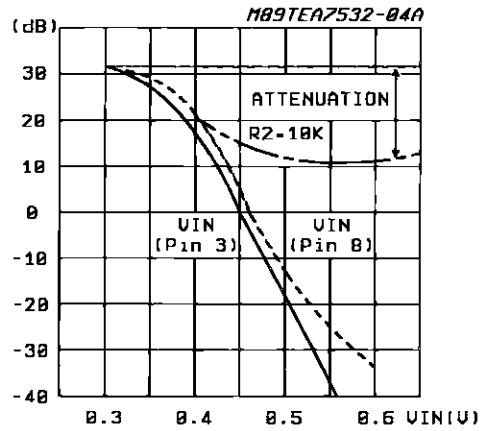

Figure 2 : Loudspeaker Gain Versus Voltage on Pin (3) - (8) and Versus R₂. (*)



(*) ATTENUATION = $\frac{Z_{in2} (1.2 K)}{Z_{in2} (1.2 K) + R_2 (E X T)}$

R₂ = 10 K ⇒ ATT = 20 dB

R₂ = 3 K ⇒ ATT ≈ 10 dB

Figure 3 : AC Output Voltage Versus Amplifier Gain.

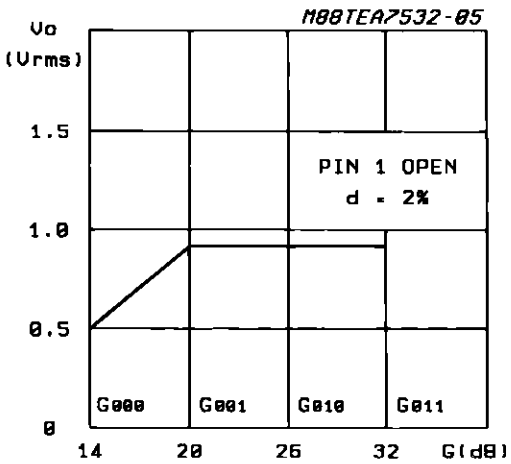

Figure 4 : Power Available on Loudspeaker Versus V_{Ls} Typical Curve.

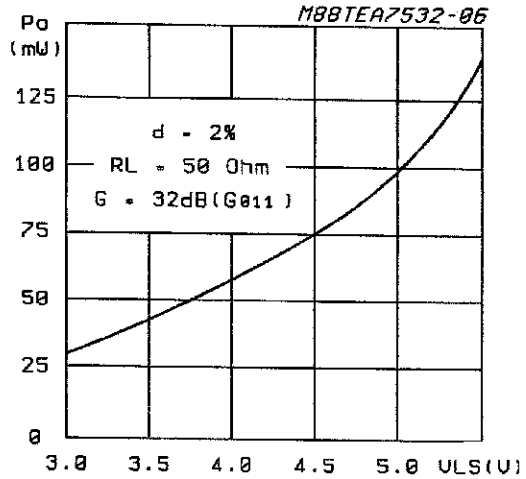

Figure 5 : Distortion Versus Output Power.

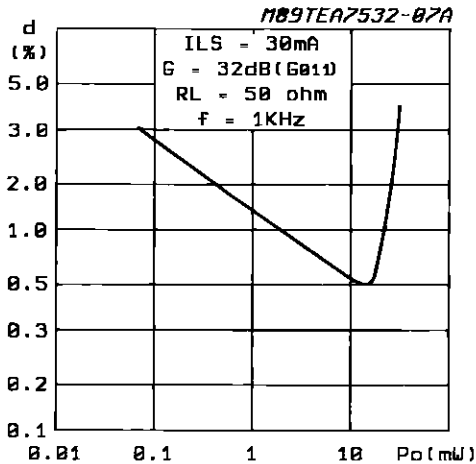
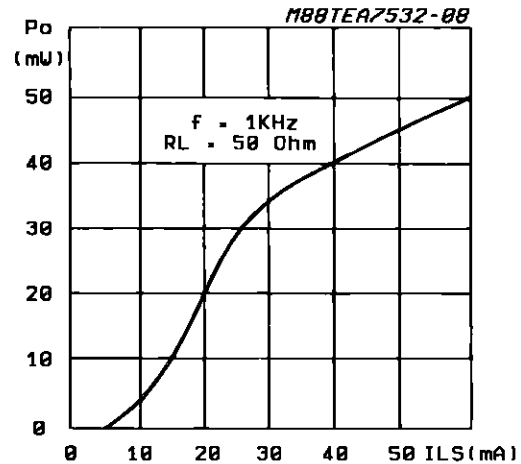

Figure 6 : Output Power Versus Supply Current.



TEST CIRCUITS

Figure 7 : Shuntvoltage Regulator/ Reference Voltage at Pin 1.

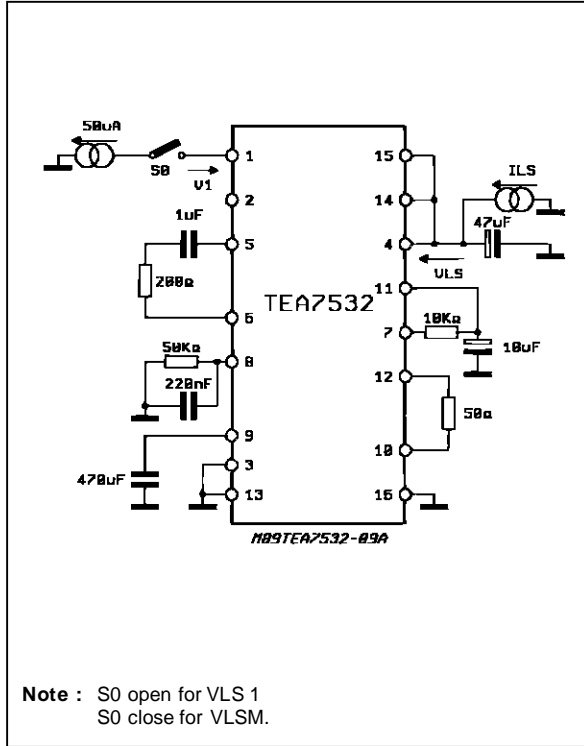

Figure 8 : Loudspeaker Amplifier : Gain/Distor tion/Output Offset.

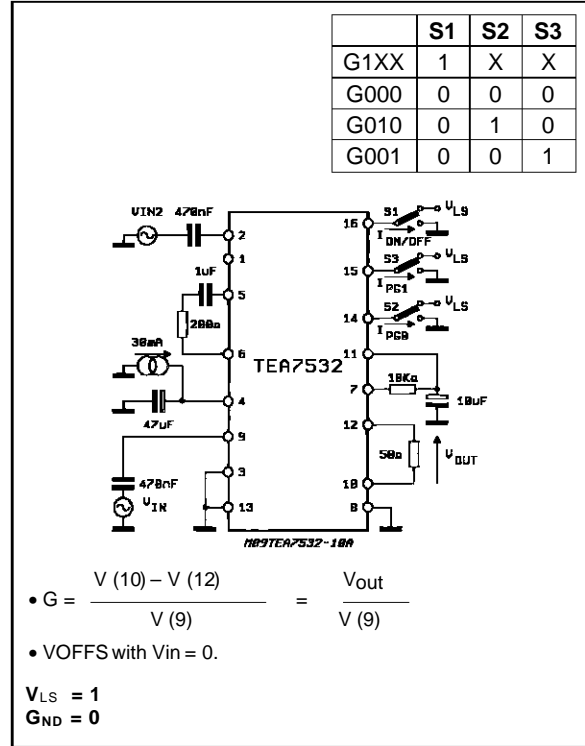

Figure 9 : Impedance ZMIC, ZINP and Zin2.

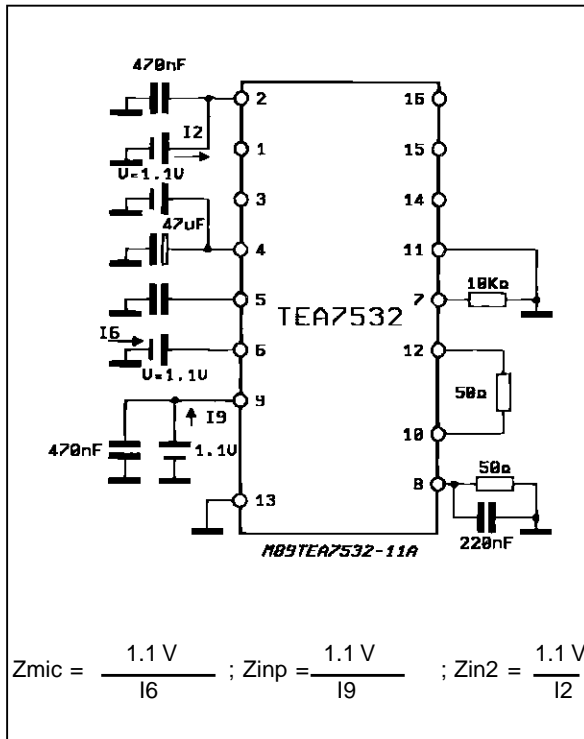
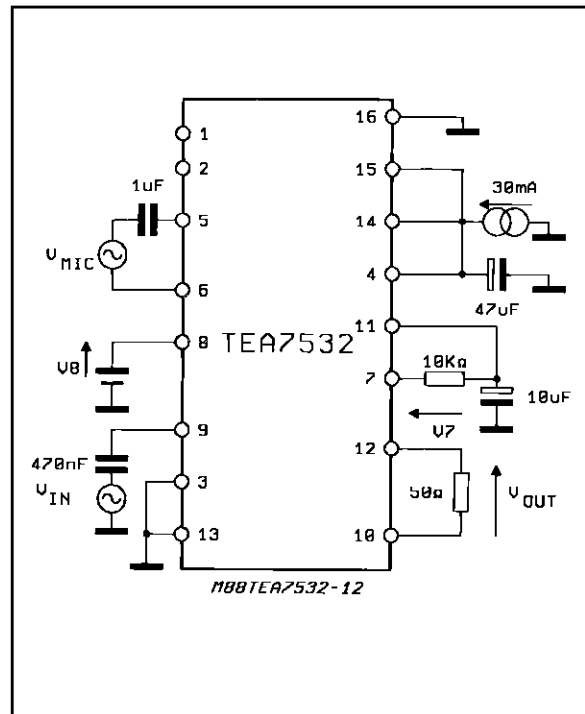

Figure 10 : Antiacoustic Feedback System at G011.



CIRCUIT DESCRIPTION

TEA7532 is a 16 pin DIL integrated circuit providing the following facilities :

- Loudspeaker amplifier

- Antiacoustic feed-back system (antilarsen system)

1.1. LOUDSPEAKER AMPLIFIER

Figure 11.

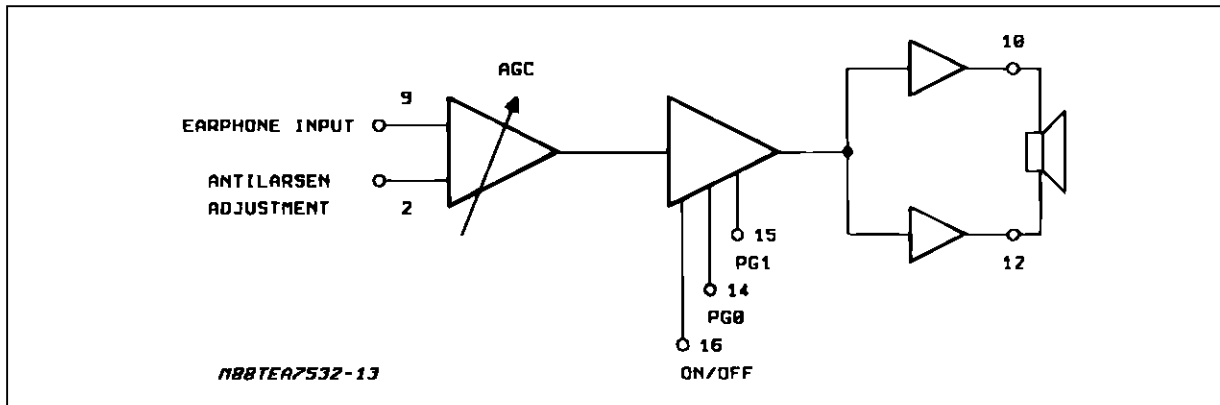

The amplifier is divided into 3 main sections.

- Automatic Gain Control (AGC)
- Preamplifier
- Push-pull amplifier (bridge structure)

a) The AGC section is used for the antilarsen and antidistortion system.

- When used in a telephone set to avoid larsen effect the AGC automatically decreases loudspeaker amplifier gain.
- When the required output level exceeds the capabilities of the available current, the AGC

decreases the loudspeaker amplifier gain to avoid distortion.

b) The preamplifier permits step control of amplifier gain in steps of 6 dB, using pins PG0 and PG1, which may be controlled using switches or by a microprocessor. The amplifier may be muted using the ON/OFF control signal (pin 16).

c) The output amplifier uses a double push-pull configuration (H bridge) to get maximum dynamic range under limited supply conditions.

Figure 12.

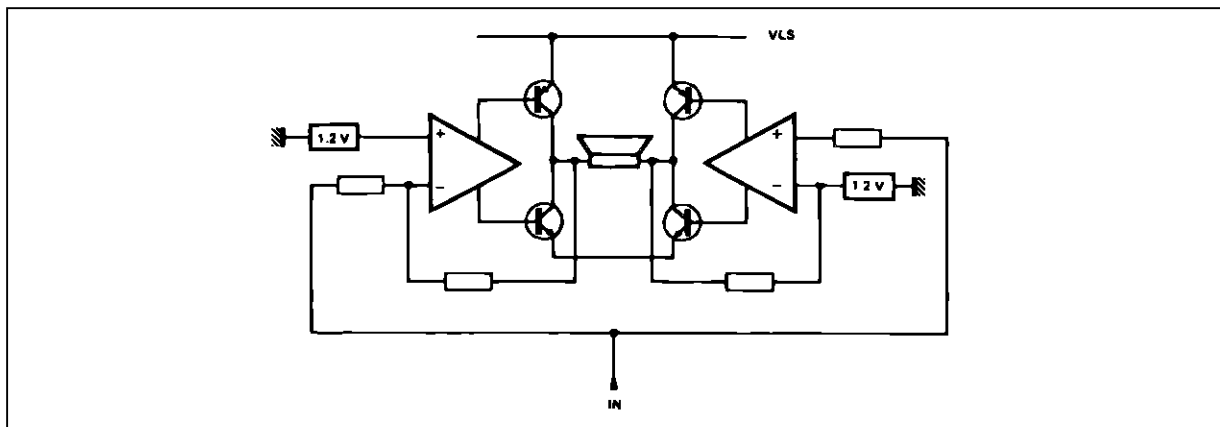

Amplifier dc supply.

In transmission mode, the supply voltage is controlled by the internal shunt DC regulator. For this reason, the TEA7532 should be supplied from a current source

(see : supply considerations).

An antidistortion system is embodied which provides AGC control to avoid loudspeaker distortion under current-limited conditions.

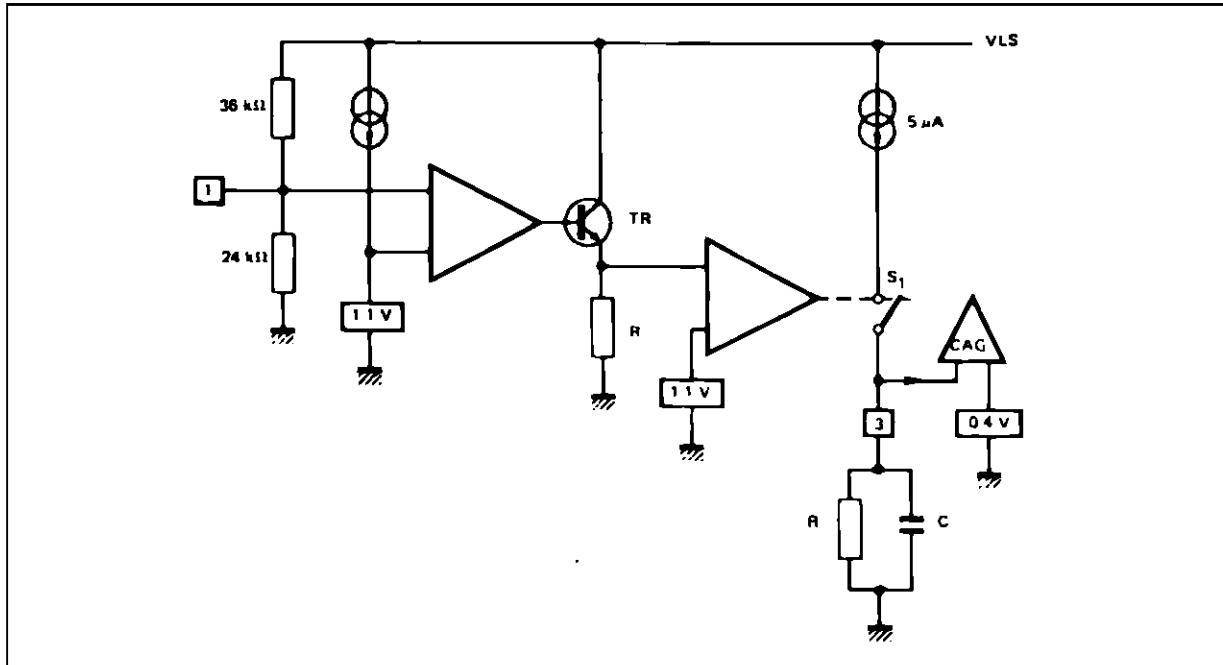
Figure 13.**Circuit action.**

When the supply voltage is insufficient, the voltage at pin 1, falls below the reference voltage 1.1 V, resulting in transistor (TR) being switched off, resulting in zero current flow in resistor R. This state enables the gain control system. Under these conditions, the shunt DC supply will switch at a rate determined by the time constant of the RC network on pin 3. This switching action accommodates normal speech

characteristics under low supply conditions.

1.2. ANTIACOUSTIC FEED-BACK SYSTEM (ANTI-LARSEN SYSTEM)

The purpose of this system is to control AGC action in order to avoid acoustic feed-back between the loudspeaker and the microphone, when used in a telephone set.

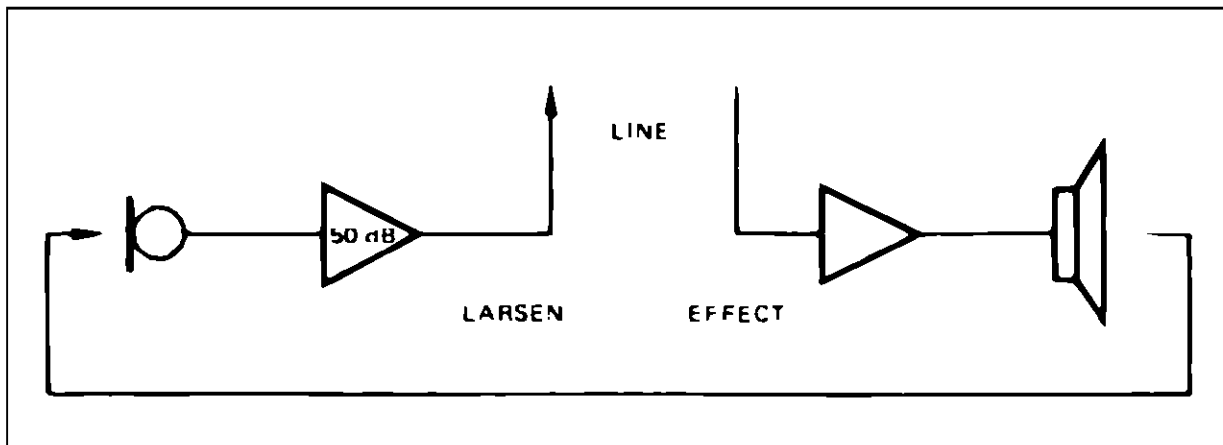
Figure 14 .

Principle of operation.

When examining the spectral density of the voice area and the larsen area, it can be seen that the

dominant features of each exist in different frequency bands.

Figure 15.

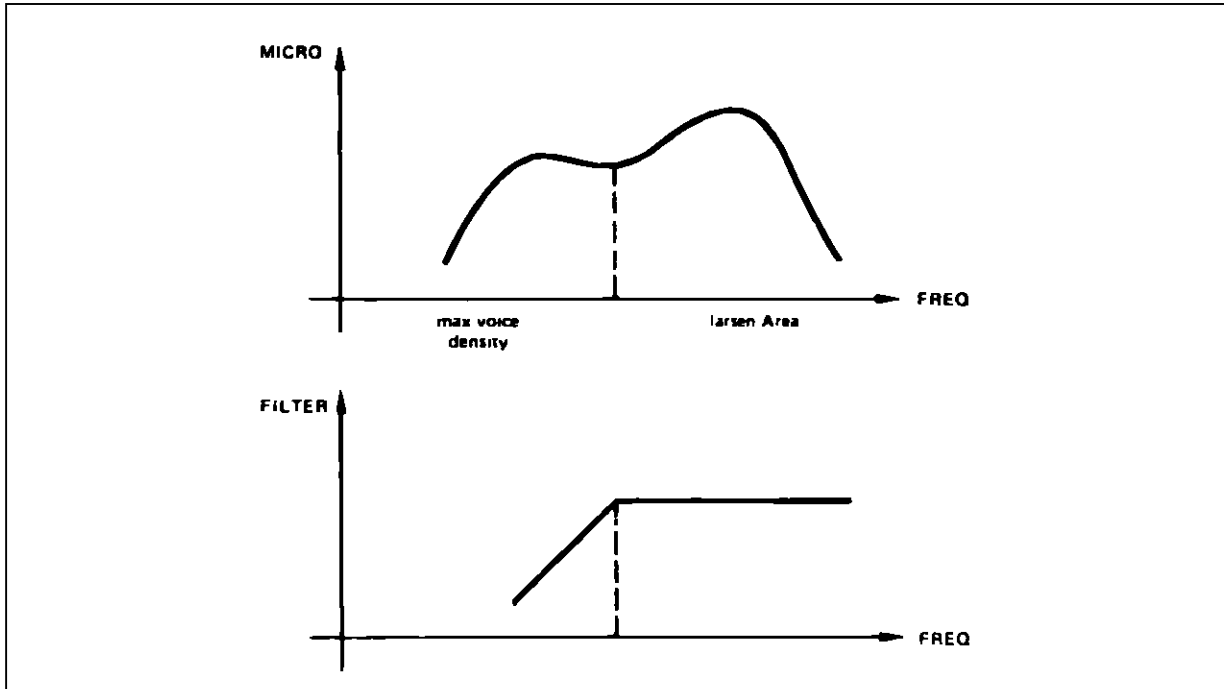

To extract the larsen component, the microphone signal is first filtered by a second order filter (formed

by two first order filters), then amplified and rectified in order to produce the AGC control signal.

Figure 16.

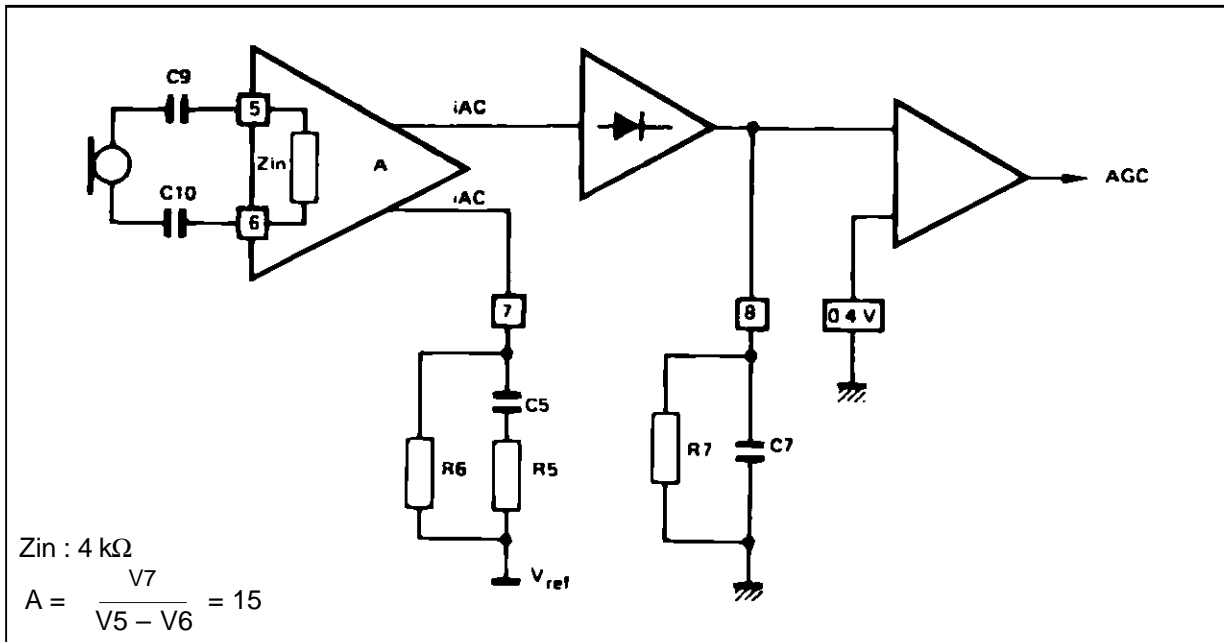

The first filter is generated by the capacitors on pins 5 and 6 ; the second filter by the R-C network on pin 7.

Figure 17 : Antilarsen System Filter Response.

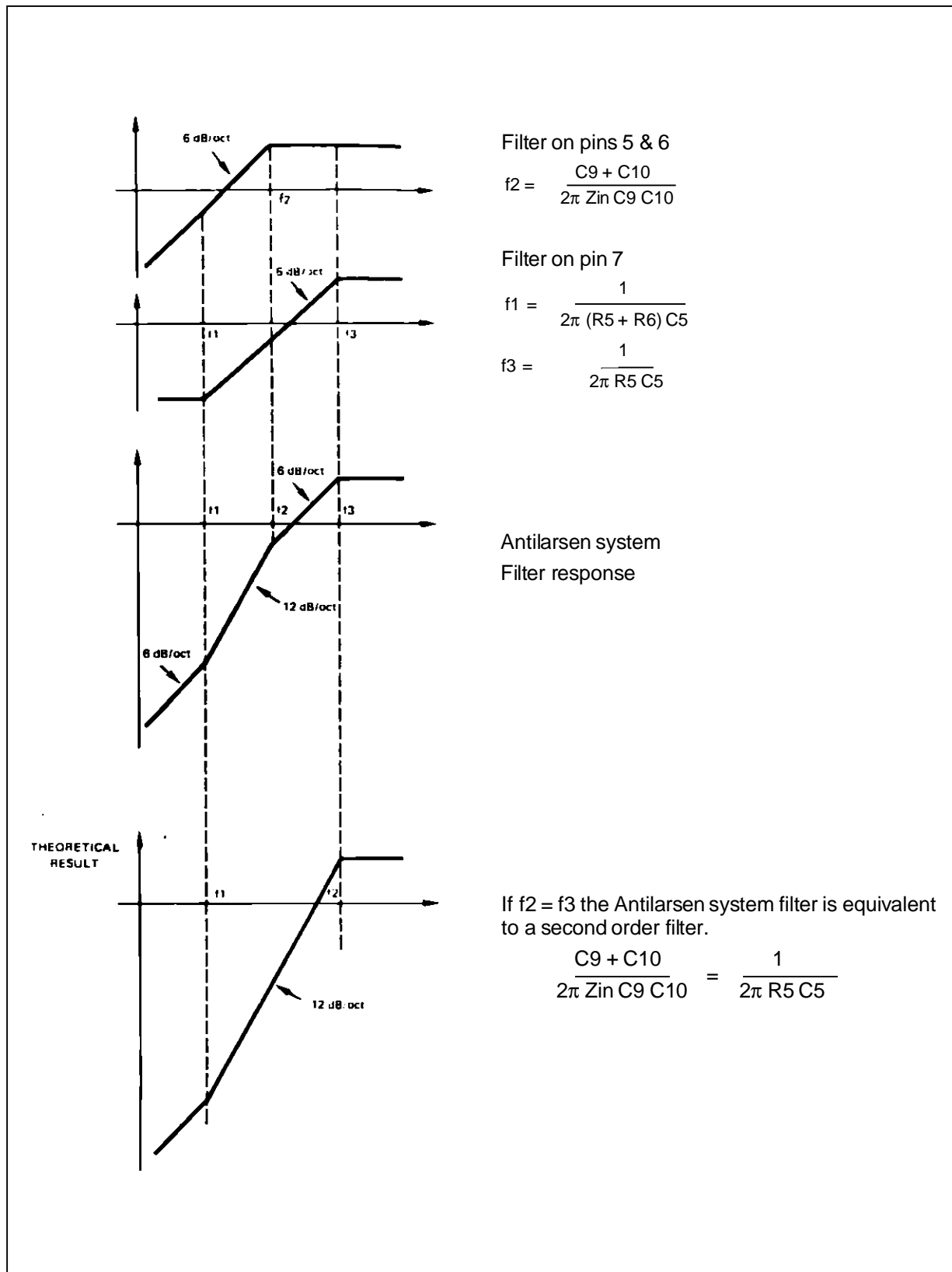

TEA7532

A complete telephone set has two antilarсен systems :

- one in the transmission circuit (for example : TEA7051) antisidetone network ;
- one in the loudspeaker amplifier (for example : TEA7532).

Together these form a high efficiency antilarсен system.

Figure 18.

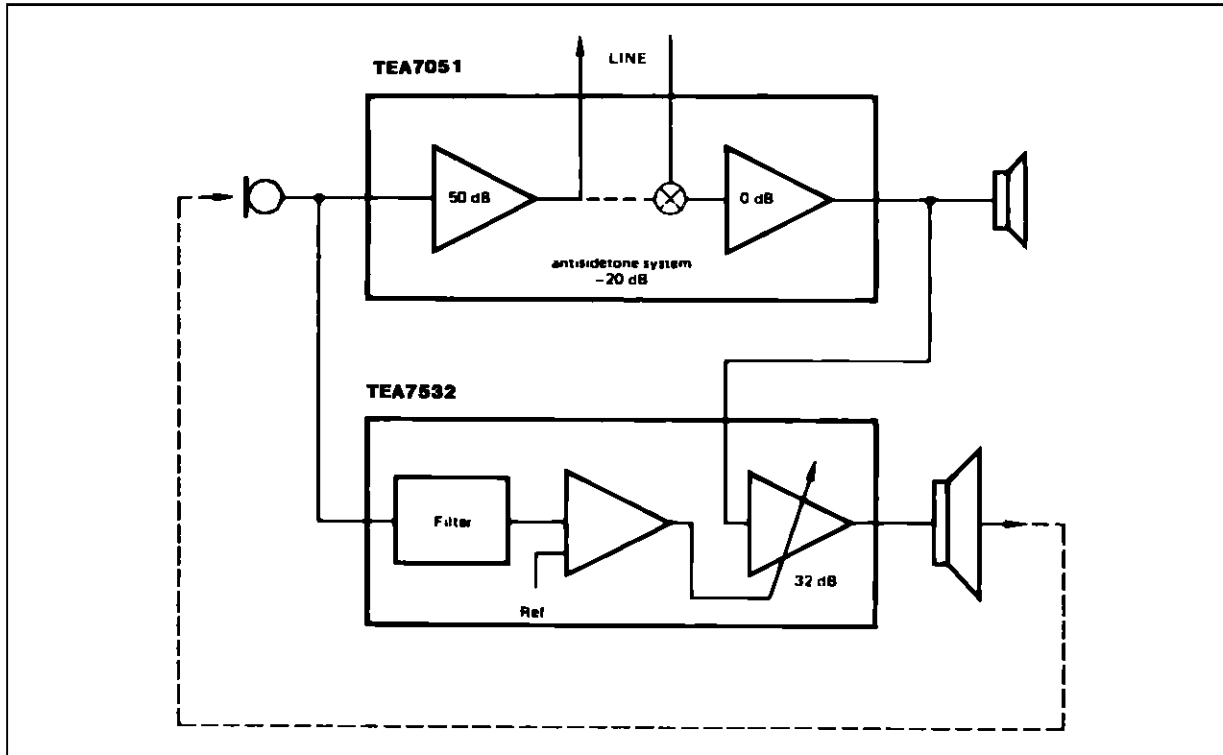

PIN FUNCTIONS

PIN 1 : ADJUST V_{LS}

This pin is used to adjust the IC supply voltage.

PIN 2 : ANTILARSEN ADJUSTMENT

The AC signal at this pin is amplified to the loudspeaker without AGC attenuation.

PIN 3 : AUTOMATIC GAIN CONTROL FILTER

The antidistortion system response is adjusted by the R-C network on this pin.

The AGC will be switched ON when the level on pin 3 is greater than the reference voltage (0.4V), the RC-network charges (current source ON) or discharges (current source OFF) according to the supply voltage.

THEORETICAL VOLTAGE ON PIN 3

Figure 19 :

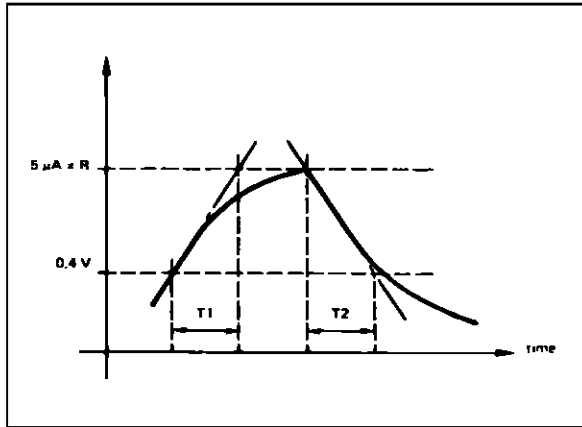

- The value of R affects the system time constant and the charge/discharge duty cycle.
- The value of C only affects the system time constant.
- R should be greater or equal than 150 kΩ for correct AGC operation.

Figure 20.

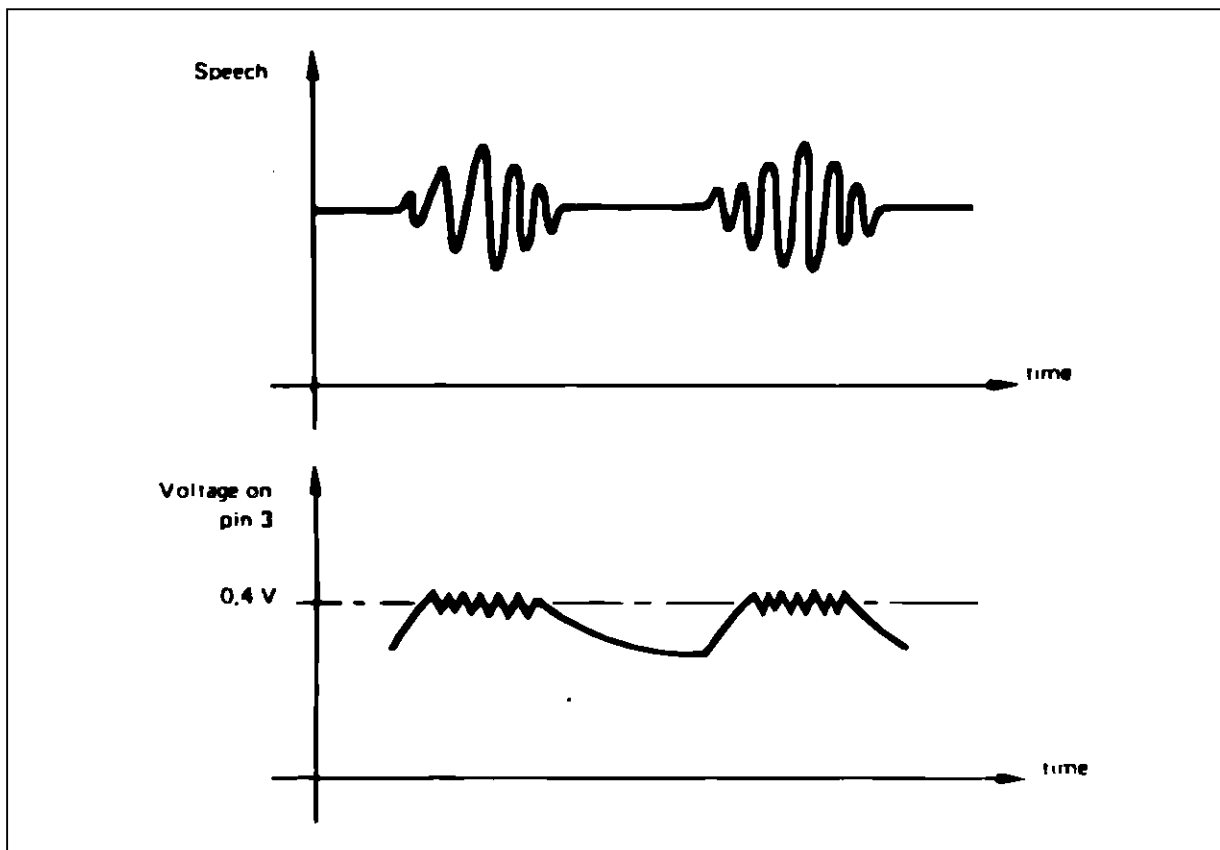
**PIN 4 : CIRCUIT SUPPLY VOLTAGE**

With pin 1 open circuit, VLS is internally stabilized at 2.8 V.

When the TEA7532 is under AGC control, the voltage on this pin varies slightly (due to AGC action).

TEA7532

PIN 5/6 : MICROPHONE INPUTS

These are used for antilarсен control.

PIN 7 : ANTILARSEN FILTER 1

The second filter of the antilarсен system (1st filter : pins 5-6) is formed by the RC network R5C5. In order to obtain a second order filter for the antilarсен system, the cut-off frequency defined at this pin, should be the same as that chosen for the first filter.

For correct TEA7532 operation R6 and R5 should be fixed at 10 k Ω and 1 k Ω respectively.

PIN 8 : ANTILARSEN FILTER 2

The gain and the response of the antilarсен system can be adjusted respectively by the resistor and the capacitor on this pin, according to the acoustic characteristics of the telephone set.

The value of the resistor should not exceed 390 k Ω . When the voltage on this pin exceeds the threshold voltage of 0.4 V, the AGC system is enabled.

PIN 9 : EARPHONE INPUT

Input for loudspeaker signal.

PIN 10-12 : LOUDSPEAKER OUTPUTS

Maximum output voltage : $V_{pp} = 2 V_{LS} - 2.5 V$ (with a gain of 32 dB).

Maximum output current : depending of the supply current.

Two loudspeaker connection methods are possible, using the amplifier in either "H" mode or "B" mode.

Note : It is advisable to connect a 47 nF capacitor in parallel with the loudspeaker (between pins 10 and 12).

- "H" Mode

This is for low voltage working, but at a higher supply current. The highest output power is available in this mode, due to the 5.5 V maximum supply voltage restriction, imposed by the TEA7532.

Loudspeaker impedance recommended value : 50 Ω . Maximum gain available between earphone input and loudspeaker output : 32 dB.

Figure 21.

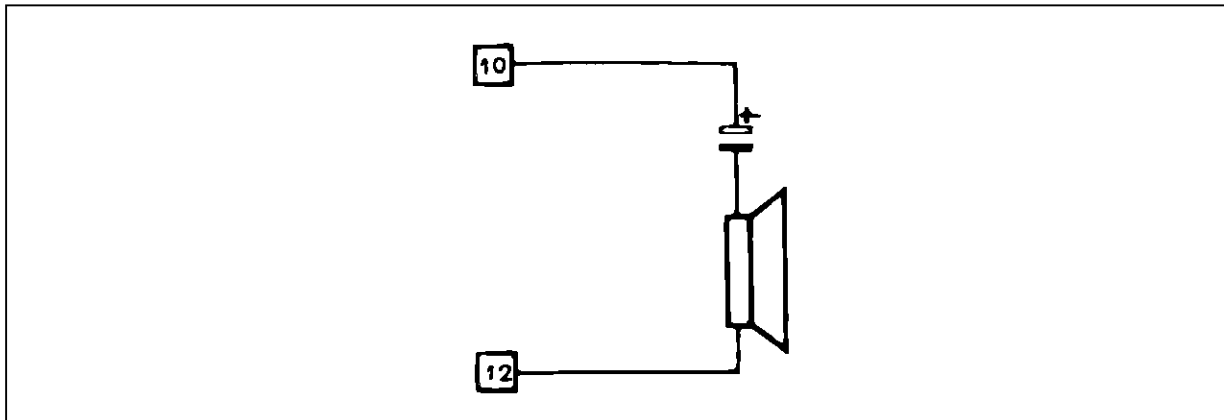
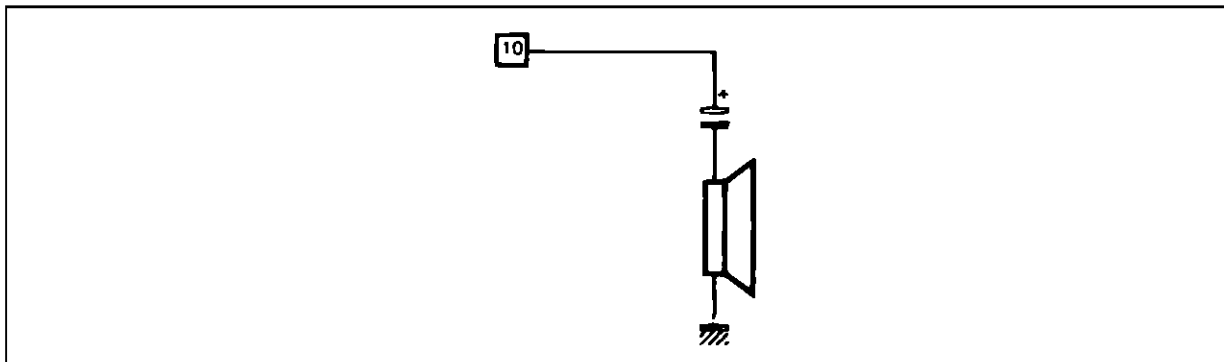

Figure 22.



- "B" Mode

This allows higher voltage operation, but at a lower supply current.

Loudspeaker impedance recommended value : 25Ω .

Maximum gain available between earphone input and loudspeaker output : $32 - 6 = 26$ dB.

PIN 11 : Vref : INTERNAL REFERENCE

Output which provides an internally regulated reference voltage.

Vref = 1.1 V typical

MAXIMUM AVAILABLE CURRENT : $5\mu\text{A}$

Figure 23.

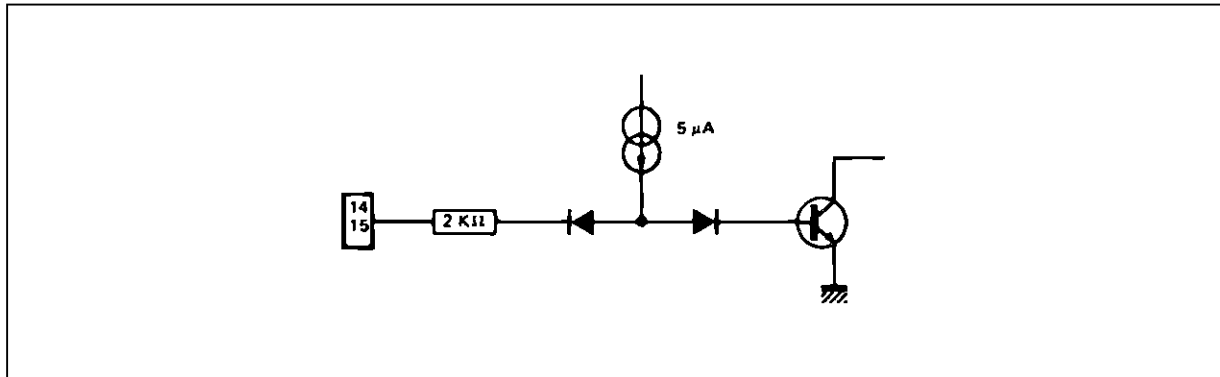
**PIN 13 : GROUND****PIN 14-15 : GAIN ADJUSTMENT INPUTS**

These pins are used to adjust the loudspeaker amplifier gain. Four steps of 6 dB/step are available (pin open circuit = high level).

PIN 16 : LOUDSPEAKER MUTING.

This pin is used to mute the loudspeaker. Pin open-circuit : high level = loudspeaker muted.

Pin low level : loudspeaker enabled (see connection of pins 14 and 15).

PG0	PG1	
1	1	Gmax
1	0	Gmax - <0> 6 dB
0	1	Gmax - 12 dB
0	0	Gmax - 18 dB

DIP16 PACKAGE MECHANICAL DATA

DIM.	mm			inch		
	Min.	Typ.	Max.	Min.	Typ.	Max.
a1	0.51			0.020		
B	0.77		1.65	0.030		0.065
b		0.5			0.020	
b1		0.25			0.010	
D			20			0.787
E		8.5			0.335	
e		2.54			0.100	
e3		17.78			0.700	
F			7.1			0.280
i			5.1			0.201
L		3.3			0.130	
Z			1.27			0.050

DIP16.TBL

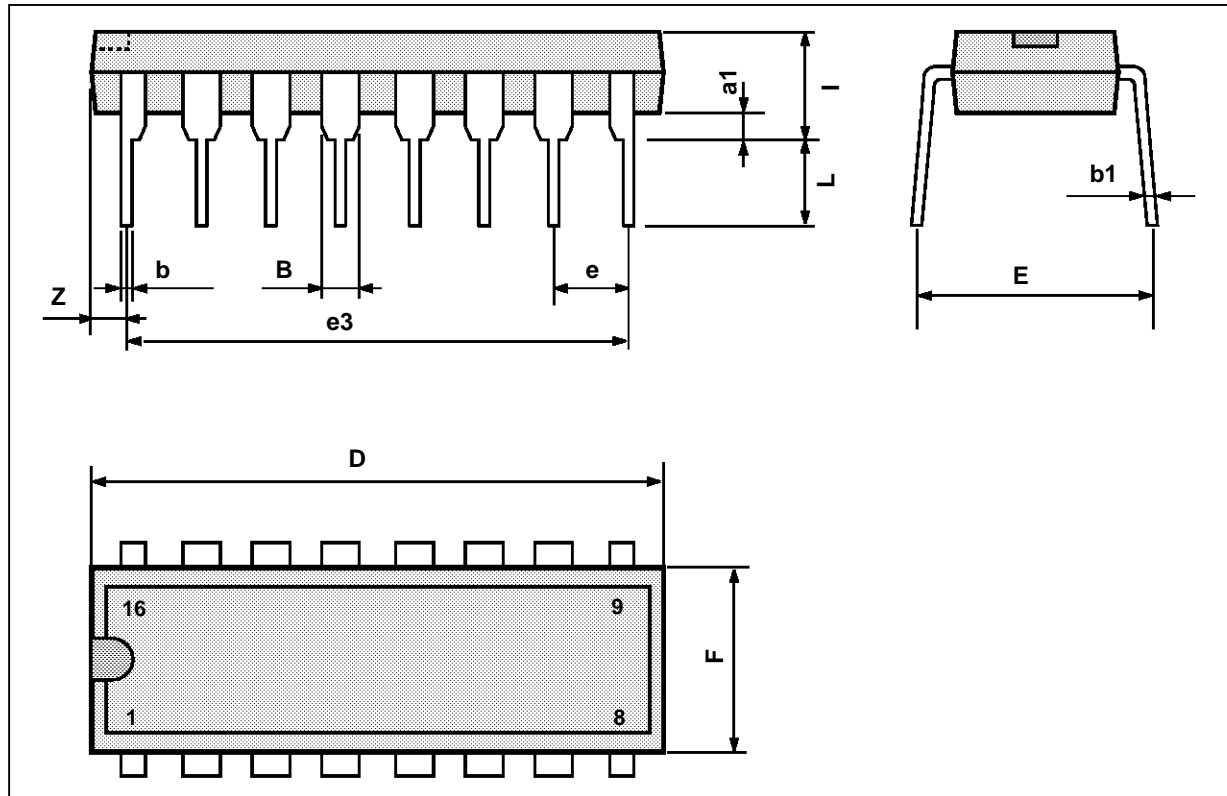

PM-DIP16.EPS

SO16 PACKAGE MECHANICAL DATA

Dimensions	Millimeters			Inches		
	Min.	Typ.	Max.	Min.	Typ.	Max.
A			1.75			0.069
a1	0.1		0.2	0.004		0.008
a2			1.6			0.063
b	0.35		0.46	0.014		0.018
b1	0.19		0.25	0.007		0.010
C		0.5			0.020	
c1	45° (typ.)					
D	9.8		10	0.386		0.394
E	5.8		6.2	0.228		0.244
e		1.27			0.050	
e3		8.89			0.350	
F	3.8		4.0	0.150		0.157
G	4.6		5.3	0.181		0.209
L	0.5		1.27	0.020		0.050
M			0.62			0.024
S	8° (max.)					

SO16.TBL

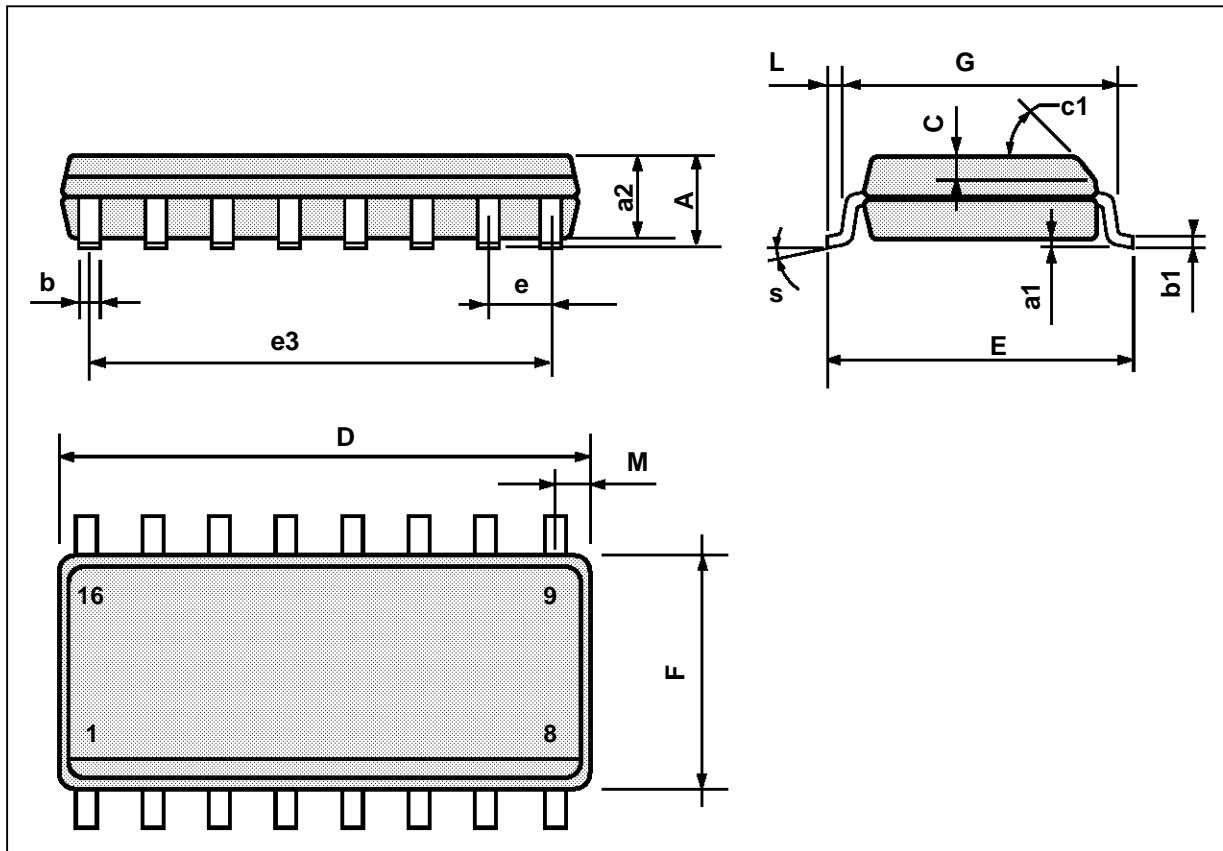

PM-SO16.EPS

Information furnished is believed to be accurate and reliable. However, SGS-THOMSON Microelectronics assumes no responsibility for the consequences of use of such information nor for any infringement of patents or other rights of third parties which may result from its use. No license is granted by implication or otherwise under any patent or patent rights of SGS-THOMSON Microelectronics. Specifications mentioned in this publication are subject to change without notice. This publication supersedes and replaces all information previously supplied. SGS-THOMSON Microelectronics products are not authorized for use as critical components in life support devices or systems without express written approval of SGS-THOMSON Microelectronics.

© 1994 SGS-THOMSON Microelectronics - All Rights Reserved

SGS-THOMSON Microelectronics GROUP OF COMPANIES

Australia - Brazil - France - Germany - Hong Kong - Italy - Japan - Korea - Malaysia - Malta - Morocco - The Netherlands
Singapore - Spain - Sweden - Switzerland - Taiwan - Thailand - United Kingdom - U.S.A.