

66079**OPTICALLY COUPLED DIGITAL FILTER****Mii****OPTOELECTRONIC PRODUCTS
DIVISION****Features:**

- DSCC Approved 916761HXX
- 10 MBd typical
- Meets Tempest EMI/RFI emanation criteria
- TTL compatible input and output
- RFI Rejection 80dB to 1GHz
- Faraday shield to provide high common mode rejection

Applications:

- Military and space
- Secure communication systems
- Isolated receiver input
- Microprocessor system interface
- Digital isolation for A/D, D/A converters

DESCRIPTION

The **66079** Optically Coupled Digital Filter consists of an LED optically coupled to a high speed, high gain inverting detector gate. Maximum isolation can be achieved while providing a TTL output capable of switching with propagation delays of 55nS typical. The 66079 is a hermetically sealed package which is threaded in order to provide convenient bulkhead mounting and is available in standard and screened versions or tested to customer specifications. The 66079-001 is a hermetically sealed package which can be soldered or press-fit mounted and is also available in standard and MIL-PRF-38534 screened versions or tested to customer specifications.

ABSOLUTE MAXIMUM RATINGS

Storage Temperature.....	-65°C to +150°C
Operating Free-Air Temperature Range	-55°C to +125°C
Lead Solder Temperature.....	260°C for 10s (1.6mm below seating plane)
Peak Forward Input Current	40mA (1ms duration)
Forward Input Current Continuous	20mA
Supply voltage - V_{CC}	7V(1 minute maximum)
Output Current - I_O	25mA
Output Power Dissipation	40mW
Output Voltage - V_O	7V
Total Power Dissipation	175mW

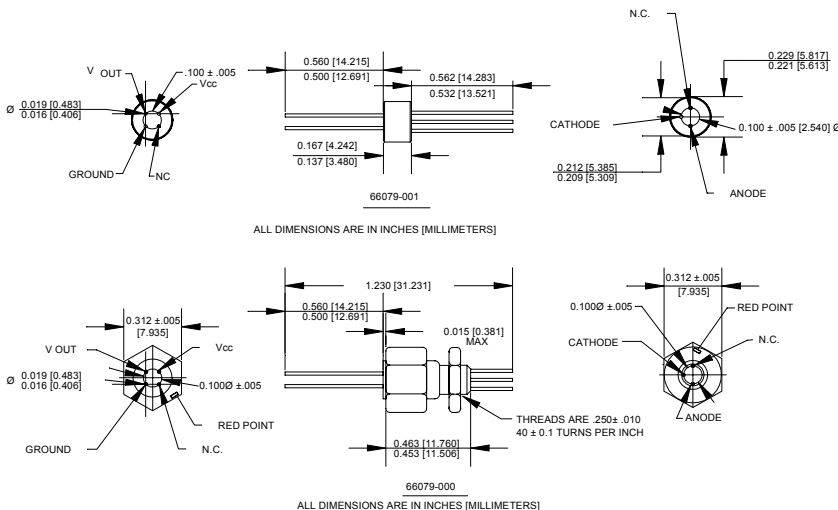
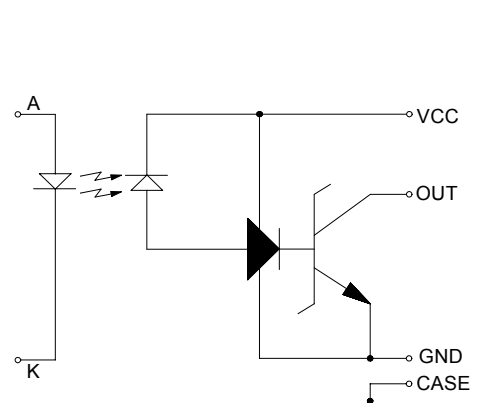
Package Dimensions**Schematic Diagram**

NOTE:
A.01 TO 0.1 μ F BYPASS
CAPACITOR MUST BE
CONNECTED BETWEEN
 V_{CC} AND GROUND.

ELECTRICAL CHARACTERISTICS $T_a = -55^{\circ}\text{C}$ to $+125^{\circ}\text{C}$ unless otherwise specified.

PARAMETER	SYMBOL	MIN	TYP	MAX	UNITS	TEST CONDITIONS	NOTE
High Level Output Current	I_{OH}		5	250	μA	$V_{CC} = 5.5\text{V}$, $V_O = 5.5\text{V}$, $I_F = 250\mu\text{A}$	
Low Level Output Voltage	V_{OL}		0.5	0.6	V	$V_{CC} = 5.5\text{V}$, $I_F = 10\text{mA}$ I_{OL} (Sinking) = 10mA	
High Level Supply Current	I_{CCH}		10	20	mA	$V_{CC} = 5.5\text{V}$, $I_F = 0$ (Both Channels)	
Low Level Supply Current	I_{CCL}		20	30	mA	$V_{CC} = 5.5\text{V}$, $I_F = 20\text{mA}$ (Both Channels)	
Input Forward Voltage	V_F		1.5	1.75	V	$I_F = 20\text{mA}$	
Input Reverse Breakdown Voltage	BV_R	5			V	$I_R = 10\mu\text{A}$	
Input-Output Insulation Leakage Current	I_{I-O}			1.0	μA	$V_{I-O} = 1500\text{Vdc}$, Relative Humidity = 45% $T_a = 25^{\circ}\text{C}$, $t = 5\text{s}$	
Propagation Delay Time To High Output Level	t_{PLH}		65	100	ns	$R_L = 510\Omega$, $C_L = 15\text{pF}$, $I_F = 13\text{mA}$, $t_a = 25^{\circ}\text{C}$	
Propagation Delay Time To Low Output Level	t_{PHL}		55	100	ns	$R_L = 510\Omega$, $C_L = 15\text{pF}$, $I_F = 13\text{mA}$, $t_a = 25^{\circ}\text{C}$	

TYPICAL CHARACTERISTICS $T_a = 25^{\circ}\text{C}$, $V_{CC} = 5\text{V}$ EACH CHANNEL

PARAMETER	SYMBOL	MIN	TYP	MAX	UNITS	TEST CONDITIONS	NOTE
Input Capacitance	C_{IN}		60			$V_F = 0$, $f = \text{MHz}$	
Input to Case Capacitance	C_{IC}		2	5	pF	$V_F = 0$, $f = \text{MHz}$	
Input Diode Temperature Coefficient	ΔV_F		-1.9		mV/°C	$I_F = 20\text{mA}$	
Capacitance (Input-Output)	C_{I-O}		1	3	pF	$f = 1\text{MHz}$	
Output Rise-Fall Time (10-90%)	t_r , t_f		35		ns	$R_L = 510\Omega$, $C_L = 50\text{pF}$ $I_F = 13\text{mA}$	
Common Mode Transient Immunity at High Output Level	CM_H	1000	10000		V/ μs	$V_{CM} = 10\text{V}$ (peak), V_O (min) = 2V, $R_L = 510\Omega$, $I_F = 0\text{mA}$	1
Common Mode Transient Immunity at Low Output Level	CM_L	1000	10000		V/ μs	$V_{CM} = 10\text{V}$ (peak), V_O (max) = 0.8V, $R_L = 510\Omega$, $I_F = 10\text{mA}$	2

NOTES:

- CM_H is the max. tolerable common mode transient to assure that the output will remain in a high logic state (i.e. $V_O > 2.0\text{V}$).
- CM_L is the max. tolerable common mode transient to assure that the output will remain in a low logic state (i.e. $V_O < 0.8\text{V}$).

RECOMMENDED OPERATING CONDITIONS:

PARAMETER	SYMBOL	MIN	MAX	UNITS
Input Current, Low Level Each Channel	I_{FL}	0	250	μA
Input Current, High Level Each Channel	I_{FH}	12.5	20	mA
Supply Voltage	V_C	4.5	5.5	V
Fan Out (TTL Load) Each Channel	N		6	
Operating Temperature	T_A	-55	125	°C

SELECTION GUIDE

PART NUMBER	PART DESCRIPTION
66079-000	With housing, with 100% screening
66079-000C	DSCC Drawing # 5962-916761HXX, with housing
66079-001	Without housing, with 100% screening
66079-001C	DSCC Drawing #5962-916760HXX (without housing)
66079-002	With housing, commercial mil-temp (-55°C to +125°C)
66079-003	Without housing, commercial mil-temp (-55°C to +125°C)
66079-004	Without housing, commercial extended temp (-40°C to +80°C)
66079-004H	With housing, commercial extended temp (-40°C to +80°C)
66079-005	Without housing, commercial temp (0°C to +70°C)
66079-005H	With housing, commercial temp (0°C to +70°C)



LittleDiode supplies new, hard to find or obsolete electronic components and semiconductors all over the world.

With over two million different components listed you are sure to find the part you need.

Feel free to visit us today at our online store:

LittleDiode.com

Looking forward to providing you with the best possible service.