

## IL215A/216A/217A PHOTOTRANSISTOR SMALL OUTLINE SURFACE MOUNT OPTOCOUPLER

- **FEATURES**
- **High Current Transfer Ratio,  $I_F=1$  mA**  
 IL215A—20% Minimum  
 IL216A—50% Minimum  
 IL217A—100% Minimum
- **Isolation Voltage, 2500 VAC<sub>RMS</sub>**
- **Electrical Specifications Similar to Standard 6 Pin Coupler**
- **Industry Standard SOIC-8 Surface Mountable Package**
- **Standard Lead Spacing, .05"**
- **Available in Tape and Reel Option (Conforms to EIA Standard RS481A)**
- **Compatible with Dual Wave, Vapor Phase and IR Reflow Soldering**
- **Underwriters Lab File #E52744 (Code Letter P)**

### DESCRIPTION

The IL215A/216A/217A are optically coupled pairs with a Gallium Arsenide infrared LED and a silicon NPN phototransistor. Signal information, including a DC level, can be transmitted by the device while maintaining a high degree of electrical isolation between input and output. The IL215A/216A/217A comes in a standard SOIC-8 small outline package for surface mounting which makes it ideally suited for high density applications with limited space. In addition to eliminating through-holes requirements, this package conforms to standards for surface mounted devices.

The high CTR at low input current is designed for low power consumption requirements such as CMOS microprocessor interfaces.

### Maximum Ratings

#### Emitter

Peak Reverse Voltage .....6.0 V  
 Continuous Forward Current ..... 60 mA  
 Power Dissipation at 25°C .....90 mW  
 Derate Linearly from 25°C .....1.2 mW/°C

#### Detector

Collector-Emitter Breakdown Voltage .....30 V  
 Emitter-Collector Breakdown Voltage .....7 V  
 Collector-Base Breakdown Voltage .....70 V  
 Power Dissipation .....150 mW  
 Derate Linearly from 25°C .....2.0 mW/°C

#### Package

Total Package Dissipation at 25°C Ambient (LED + Detector) .....280 mW  
 Derate Linearly from 25°C .....3.3 mW/°C  
 Storage Temperature ..... -55°C to +150°C  
 Operating Temperature ..... -55°C to +100°C  
 Soldering Time at 260°C ..... 10 sec.

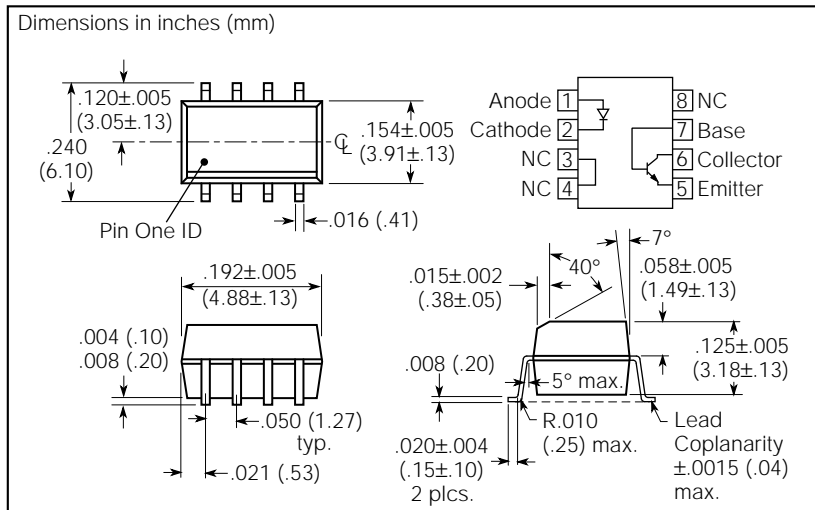

### Characteristics ( $T_A=25^\circ\text{C}$ )

	Symbol	Min.	Typ.	Max.	Unit	Condition
<b>Emitter</b>						
Forward Voltage	$V_F$		1.0	1.5	V	$I_F=1$ mA
Reverse Current	$I_R$		0.1	100	$\mu\text{A}$	$V_R=6.0$ V
Capacitance	$C_O$		25		pF	$V_R=0$
<b>Detector</b>						
Breakdown Voltage Collector-Emitter Emitter-Collector	$B_{V_{CE0}}$ $B_{V_{EC0}}$		30 7		V V	$I_C=10$ $\mu\text{A}$ $I_E=10$ $\mu\text{A}$
Dark Current, Collector-Emitter	$I_{CE0\text{dark}}$		5	50	nA	$V_{CE}=10$ V $I_F=0$
Capacitance, Collector-Emitter	$C_{CE}$		10		pF	$V_{CE}=0$
<b>Package</b>						
DC Current Transfer Ratio IL215A IL216A IL217A	$CTR_{DC}$		20 50 100	50 80 130	%	$I_F=10$ mA, $V_{CE}=5$ V
Saturation Voltage, Collector-Emitter	$V_{CE\text{sat}}$			0.5		$I_F=1$ mA, $I_C=0.1$ mA
Isolation Test Voltage	$V_{IO}$	2500			VAC <sub>RMS</sub>	
Capacitance, Input to Output	$C_{IO}$		0.5		pF	
Resistance, Input to Output	$R_{IO}$		100		G $\Omega$	
Switching Time	$t_{on}, t_{off}$		3.0		$\mu\text{s}$	$I_C=2$ mA, $R_E=100$ $\Omega$ , $V_{CE}=10$ V

Figure 1. Forward voltage versus forward current

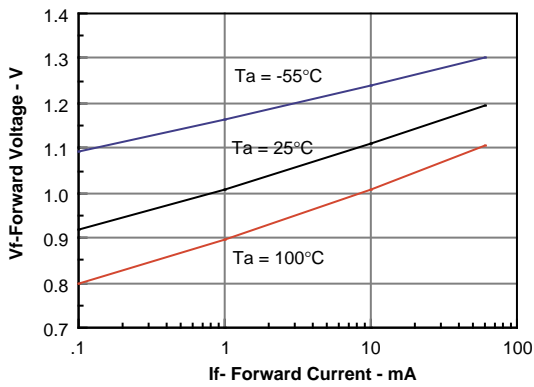

Figure 5. Collector-base photocurrent versus LED current

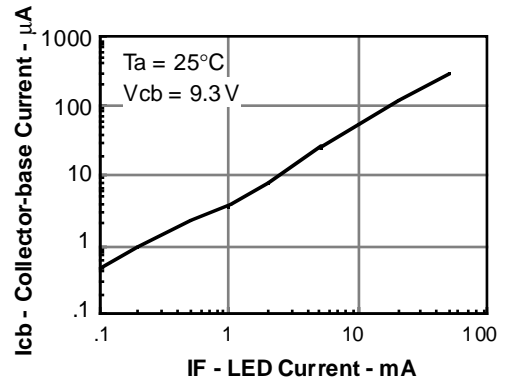

Figure 2. Normalized non-saturated and saturated  $CTR_{ce}$  versus LED current

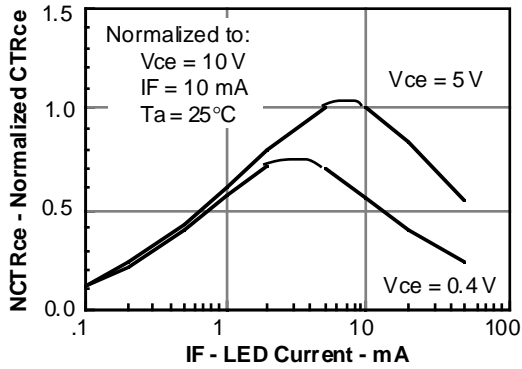

Figure 6. Collector-emitter leakage current versus temperature

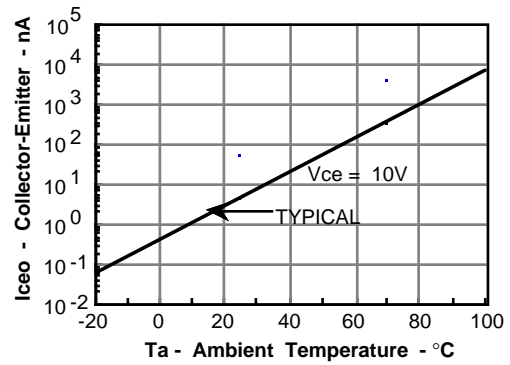

Figure 3. Collector-emitter current versus LED current

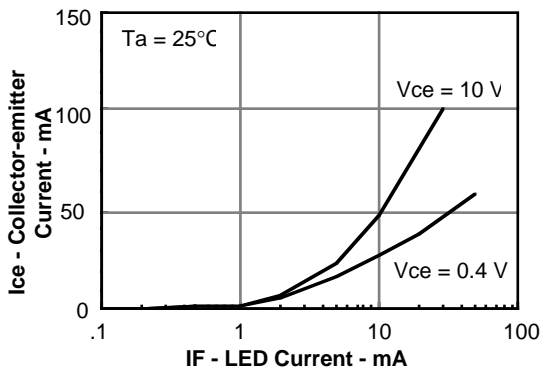

Figure 7. Normalized saturated HFE versus base current and temperature

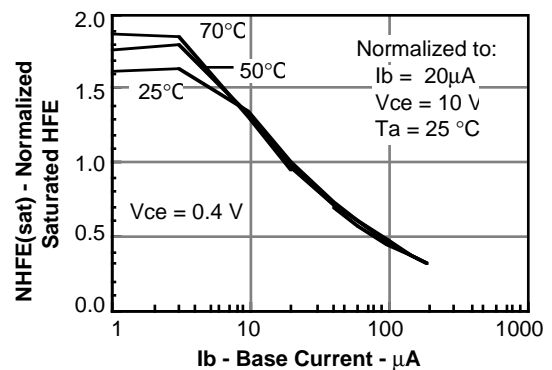

Figure 4. Normalized collector-base photocurrent versus LED current

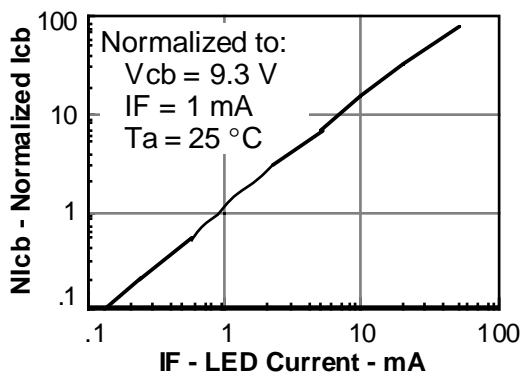
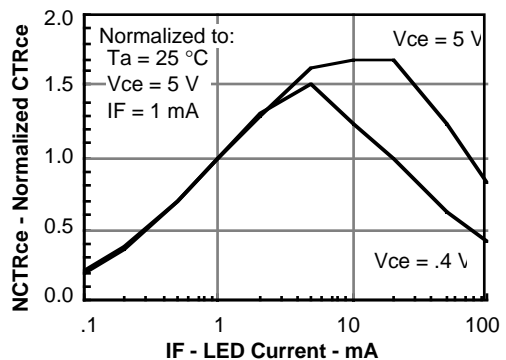
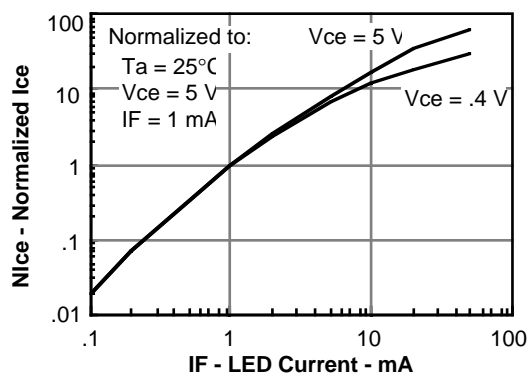

Figure 8. Normalized non-saturated and saturated  $CTR_{ce}$  versus LED current



**Figure 9. Normalized non-saturated and saturated collector-emitter current versus LED current**



**Figure 10. Normalized collector-base photocurrent versus LED current**

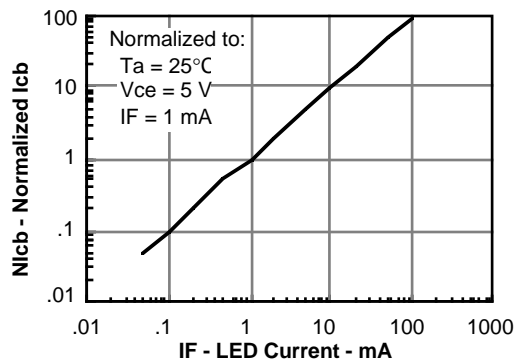

**Figure 11. Collector-base photocurrent versus LED current**

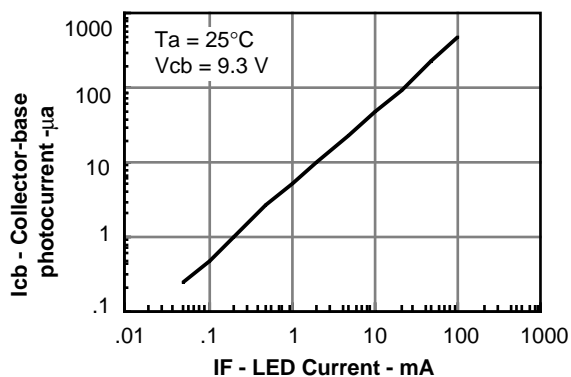

**Figure 12. High to low propagation delay versus LED current and load resistor**

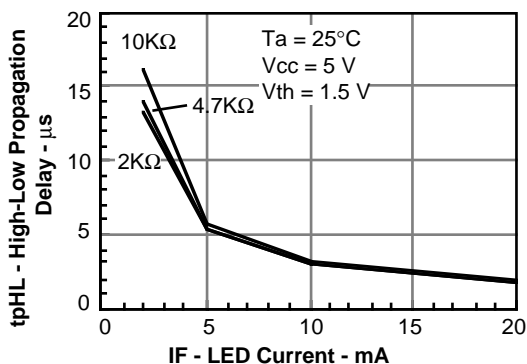

**Figure 13. Low to high propagation delay versus LED current and load resistor**

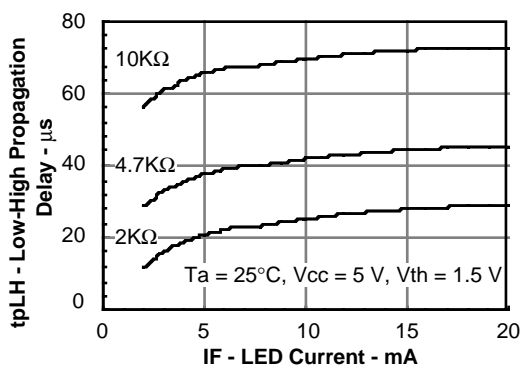

**Figure 14. Normalized non-saturated HFE versus base current and temperature**

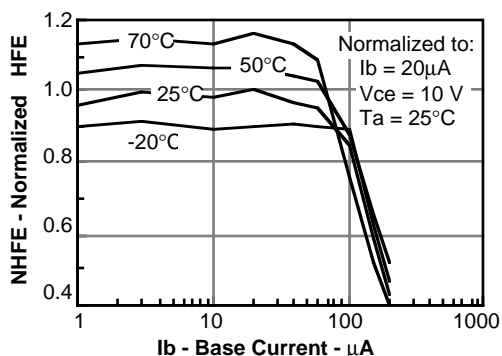

**Figure 15. Typical switching characteristics versus base resistance (saturated operation)**

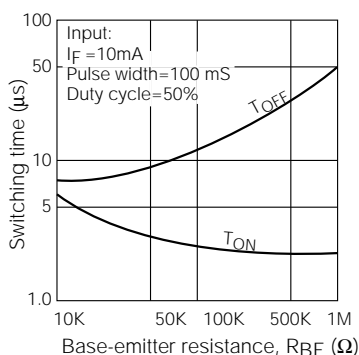

**Figure 16. Typical switching times versus load resistance**

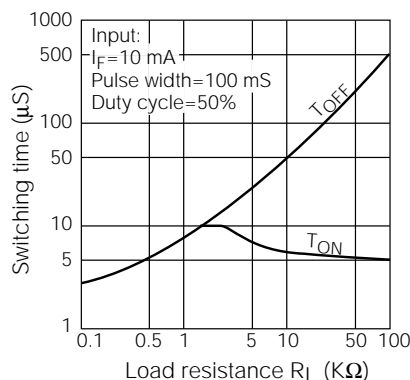

This datasheet has been downloaded from:

[www.DatasheetCatalog.com](http://www.DatasheetCatalog.com)

Datasheets for electronic components.



LittleDiode supplies new, hard to find or obsolete electronic components and semiconductors all over the world.

With over two million different components listed you are sure to find the part you need.

Feel free to visit us today at our online store:

[LittleDiode.com](http://LittleDiode.com)

Looking forward to providing you with the best possible service.