

# SN5475, SN5477, SN54LS75, SN54LS77 SN7475, SN74LS75 4-BIT BISTABLE LATCHES

SDLS120 - MARCH 1974 - REVISED MARCH 1988

**FUNCTION TABLE**  
(each latch)

INPUTS		OUTPUTS	
D	C	Q	$\bar{Q}$
L	H	L	H
H	H	H	L
X	L	$Q_0$	$\bar{Q}_0$

H = high level, L = low level, X = irrelevant  
 $Q_0$  = the level of Q before the high-to-low transition of G

## description

These latches are ideally suited for use as temporary storage for binary information between processing units and input/output or indicator units. Information present at a data (D) input is transferred to the Q output when the enable (C) is high and the Q output will follow the data input as long as the enable remains high. When the enable goes low, the information (that was present at the data input at the time the transition occurred) is retained at the Q output until the enable is permitted to go high.

The '75 and 'LS75 feature complementary Q and  $\bar{Q}$  outputs from a 4-bit latch, and are available in various 16-pin packages. For higher component density applications, the '77 and 'LS77 4-bit latches are available in 14-pin flat packages.

These circuits are completely compatible with all popular TTL families. All inputs are diode-clamped to minimize transmission-line effects and simplify system design. Series 54 and 54LS devices are characterized for operation over the full military temperature range of -55°C to 125°C; Series 74, and 74LS devices are characterized for operation from 0°C to 70°C.

**SN5475, SN54LS75 . . . J OR W PACKAGE**  
**SN7475 . . . N PACKAGE**  
**SN74LS75 . . . D OR N PACKAGE**  
 (TOP VIEW)

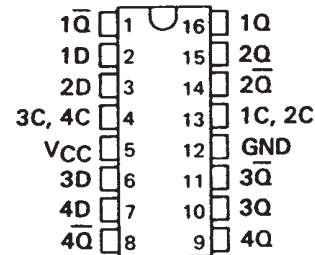

**SN5477, SN54LS77 . . . W PACKAGE**  
 (TOP VIEW)

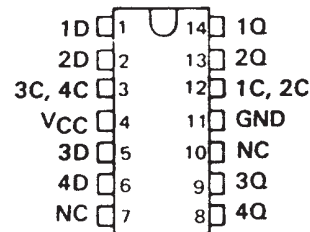

NC - No internal connection

## logic symbols†

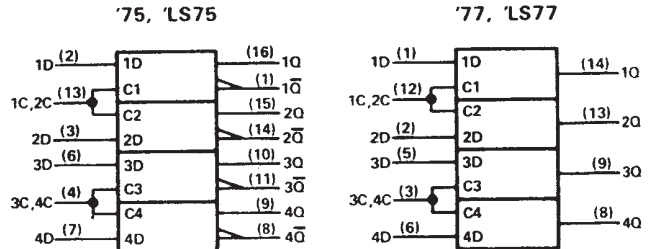

†These symbols are in accordance with ANSI/IEEE Std 91-1984 and IEC Publication 617-12.

## absolute maximum ratings over operating free-air temperature range (unless otherwise noted)

Supply voltage, $V_{CC}$ (See Note 1)	7 V
Input voltage: '75, '77	5.5 V
'LS75, 'LS77	7 V
Interemitter voltage (see Note 2)	5.5 V
Operating free-air temperature range: SN54'	-55°C to 125°C
SN74'	0°C to 70°C
Storage temperature range	-65°C to 150°C

NOTES: 1. Voltage values are with respect to network ground terminal.  
 2. This is the voltage between two emitters of a multiple-emitter input transistor and is not applicable to the 'LS75 and 'LS77.



SN5475, SN5477, SN54LS75, SN54LS77  
SN7475, SN74LS75  
4-BIT BISTABLE LATCHES

SDLS120 – MARCH 1974 – REVISED MARCH 1988

recommended operating conditions

	SN5475, SN5477			SN7475			UNIT
	MIN	NOM	MAX	MIN	NOM	MAX	
Supply voltage, $V_{CC}$	4.5	5	5.5	4.75	5	5.25	V
High-level output current, $I_{OH}$			-400			-400	$\mu$ A
Low-level output current, $I_{OL}$			16			16	mA
Width of enabling pulse, $t_w$	20			20			ns
Setup time, $t_{su}$	20			20			ns
Hold time, $t_h$	5			5			ns
Operating free-air temperature, $T_A$	-55		125	0		70	$^{\circ}$ C

electrical characteristics over recommended operating free-air temperature range (unless otherwise noted)

PARAMETER		TEST CONDITIONS†	MIN	TYP‡	MAX	UNIT
$V_{IH}$	High-level input voltage		2			V
$V_{IL}$	Low-level input voltage				0.8	V
$V_{IK}$	Input clamp voltage	$V_{CC} = \text{MIN}$ , $I_I = -12 \text{ mA}$			-1.5	V
$V_{OH}$	High-level output voltage	$V_{CC} = \text{MIN}$ , $V_{IH} = 2 \text{ V}$ , $V_{IL} = 0.8 \text{ V}$ , $I_{OH} = -400 \mu\text{A}$	2.4	3.4		V
$V_{OL}$	Low-level output voltage	$V_{CC} = \text{MIN}$ , $V_{IH} = 2 \text{ V}$ , $V_{IL} = 0.8 \text{ V}$ , $I_{OL} = 16 \text{ mA}$		0.2	0.4	V
$I_I$	Input current at maximum input voltage	$V_{CC} = \text{MAX}$ , $V_I = 5.5 \text{ V}$			1	mA
$I_{IH}$	High-level input current	D input	$V_{CC} = \text{MAX}$ , $V_I = 2.4 \text{ V}$		80	$\mu$ A
		C input			160	
$I_{IL}$	Low-level input current	D input	$V_{CC} = \text{MAX}$ , $V_I = 0.4 \text{ V}$		-3.2	mA
		C input			-6.4	
$I_{OS}$	Short-circuit output current§	$V_{CC} = \text{MAX}$	SN54*	-20	-57	mA
			SN74*	-18	-57	
$I_{CC}$	Supply current	$V_{CC} = \text{MAX}$ , See Note 3	SN54*	32	46	mA
			SN74*	32	53	

† For conditions shown as MIN or MAX, use the appropriate value specified under recommended operating conditions.

‡ All typical values are at  $V_{CC} = 5 \text{ V}$ ,  $T_A = 25^{\circ}\text{C}$ .

§ Not more than one output should be shorted at a time.

NOTE 3:  $I_{CC}$  is tested with all inputs grounded and all outputs open.

switching characteristics,  $V_{CC} = 5 \text{ V}$ ,  $T_A = 25^{\circ}\text{C}$

PARAMETER	FROM (INPUT)	TO (OUTPUT)	TEST CONDITIONS	MIN	TYP	MAX	UNIT
$t_{PLH}$	D	Q	$C_L = 15 \text{ pF}$ , $R_L = 400 \Omega$ , See Figure 1	16	30	ns	
$t_{PHL}$				14	25		
$t_{PLH}\ddagger$	D	$\bar{Q}$		24	40	ns	
$t_{PHL}\ddagger$				7	15		
$t_{PLH}$	C	Q		16	30	ns	
$t_{PHL}$				7	15		
$t_{PLH}\ddagger$	C	$\bar{Q}$		16	30	ns	
$t_{PHL}\ddagger$				7	15		

$t_{PLH} \equiv$  propagation delay time, low-to-high-level output

$t_{PHL} \equiv$  propagation delay time, high-to-low-level output

‡ These parameters are not applicable for the SN5477.



**SN5475, SN5477, SN54LS75, SN54LS77  
SN7475, SN74LS75  
4-BIT BISTABLE LATCHES**

SDLS120 – MARCH 1974 – REVISED MARCH 1988

**recommended operating conditions**

	SN54LS75 SN54LS77			SN74LS75			UNIT
	MIN	NOM	MAX	MIN	NOM	MAX	
Supply voltage, $V_{CC}$	4.5	5	5.5	4.75	5	5.25	V
High-level output current, $I_{OH}$			-400			-400	$\mu$ A
Low-level output current, $I_{OL}$			4			8	mA
Width of enabling pulse, $t_w$	20			20			ns
Setup time, $t_{su}$	20			20			ns
Hold time, $t_h$	5			5			ns
Operating free-air temperature, $T_A$	-55		125	0		70	$^{\circ}$ C

**electrical characteristics over recommended operating free-air temperature range (unless otherwise noted)**

PARAMETER	TEST CONDITIONS†	SN54LS75 SN54LS77			SN74LS75			UNIT
		MIN	TYP‡	MAX	MIN	TYP‡	MAX	
$V_{IH}$ High-level input voltage		2			2			V
$V_{IL}$ Low-level input voltage				0.7			0.8	V
$V_{IK}$ Input clamp voltage	$V_{CC} = \text{MIN}, I_I = -18 \text{ mA}$			-1.5			-1.5	V
$V_{OH}$ High-level output voltage	$V_{CC} = \text{MIN}, V_{IH} = 2 \text{ V}, V_{IL} = V_{IL \text{ max}}, I_{OH} = -400 \mu\text{A}$	2.5	3.5		2.7	3.5		V
$V_{OL}$ Low-level output voltage	$V_{CC} = \text{MIN}, V_{IH} = 2 \text{ V}, V_{IL} = V_{IL \text{ max}}$	$I_{OL} = 4 \text{ mA}$		0.25	0.4	0.25	0.4	V
		$I_{OL} = 8 \text{ mA}$				0.35	0.5	
$I_I$ Input current at maximum input voltage	$V_{CC} = \text{MAX}, V_I = 7 \text{ V}$	D input			0.1		0.1	mA
		C input			0.4		0.4	
$I_{IH}$ High-level input current	$V_{CC} = \text{MAX}, V_I = 2.7 \text{ V}$	D input			20		20	$\mu$ A
		C input			80		80	
$I_{IL}$ Low-level input current	$V_{CC} = \text{MAX}, V_I = 0.4 \text{ V}$	D input			-0.4		-0.4	mA
		C input			-1.6		-1.6	
$I_{OS}$ Short-circuit output current§	$V_{CC} = \text{MAX}$	-20		-100	-20		-100	mA
$I_{CC}$ Supply current	$V_{CC} = \text{MAX},$ See Note 2	'LS75		6.3	12	6.3	12	mA
		'LS77		6.9	13			

† For conditions shown as MIN or MAX, use the appropriate value specified under recommended operating conditions.

‡ All typical values are at  $V_{CC} = 5 \text{ V}, T_A = 25^{\circ}\text{C}$ .

§ Not more than one output should be shorted at a time, and duration of the short-circuit should not exceed one second

NOTE 2:  $I_{CC}$  is tested with all inputs grounded and all outputs open.

**switching characteristics,  $V_{CC} = 5 \text{ V}, T_A = 25^{\circ}\text{C}$**

PARAMETER¶	FROM (INPUT)	TO (OUTPUT)	TEST CONDITIONS	'LS75			'LS77			UNIT
				MIN	TYP	MAX	MIN	TYP	MAX	
$t_{PLH}$	D	Q	$C_L = 15 \text{ pF}, R_L = 2 \text{ k}\Omega,$ See Figure 1		15	27		11	19	ns
$t_{PHL}$					9	17		9	17	
$t_{PLH}$	D	$\bar{Q}$			12	20				ns
$t_{PHL}$					7	15				
$t_{PLH}$	C	Q			15	27		10	18	ns
$t_{PHL}$					14	25		10	18	
$t_{PLH}$	C	$\bar{Q}$			16	30				ns
$t_{PHL}$					7	15				

¶  $t_{PLH}$  = propagation delay time, low-to-high-level output

$t_{PHL}$  = propagation delay time, high-to-low-level output



switching characteristics†

**PARAMETER MEASUREMENT INFORMATION**

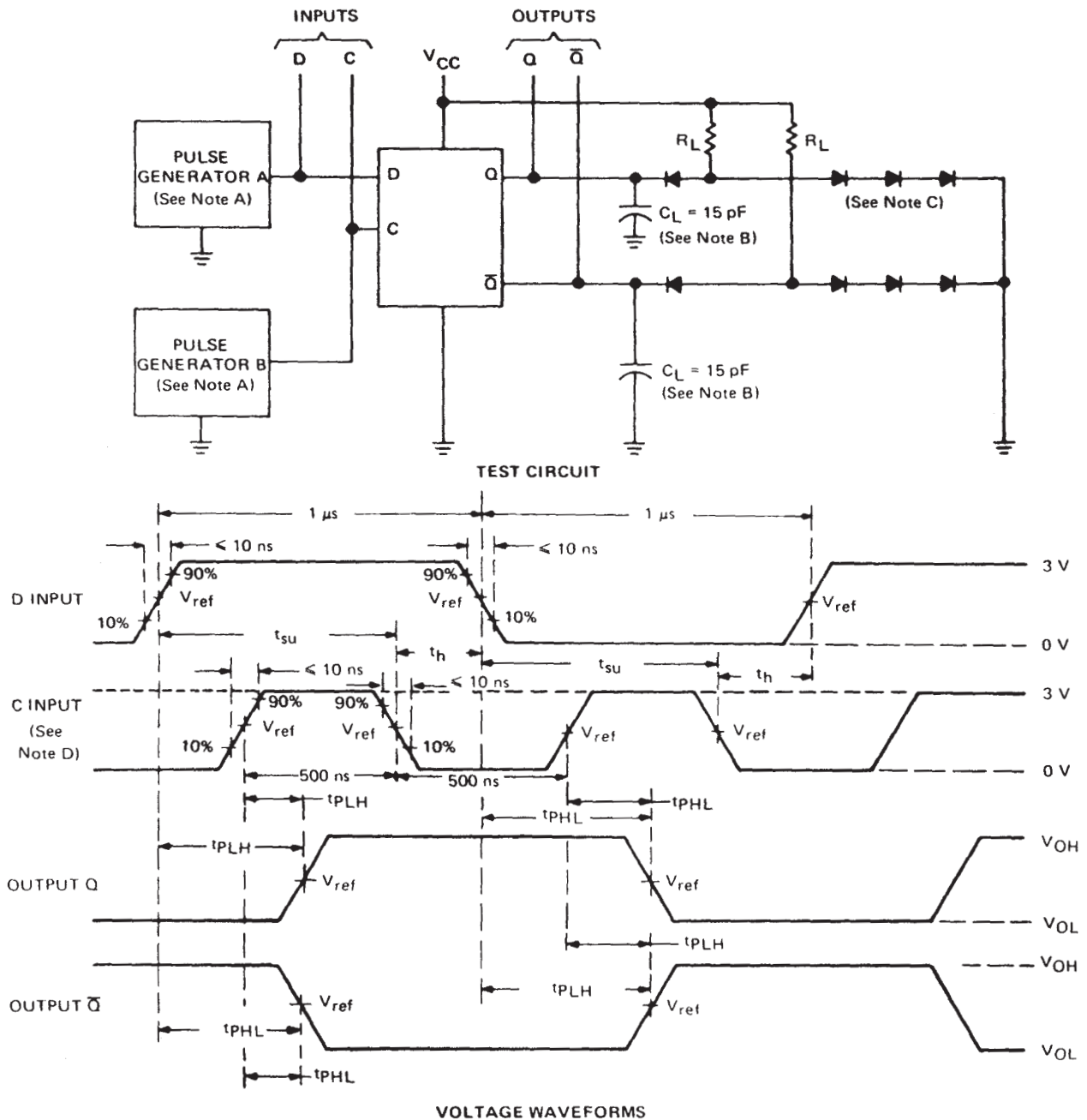

† Complementary Q outputs are on the '75 and 'LS75 only.

- NOTES: A. The pulse generators have the following characteristics:  $Z_{out} \approx 50 \Omega$ ; for pulse generator A,  $PRR \leq 500 \text{ kHz}$ ; for pulse generator B,  $PRR \leq 1 \text{ MHz}$ . Positions of D and C input pulses are varied with respect to each other to verify setup times.
- B.  $C_L$  includes probe and jig capacitance.
- C. All diodes are 1N3064 or equivalent.
- D. When measuring propagation delay times from the D input, the corresponding C input must be held high.
- E. For '75 and '77,  $V_{ref} = 1.5 \text{ V}$ ; for 'LS75 and 'LS77,  $V_{ref} = 1.3 \text{ V}$ .

FIGURE 1

## IMPORTANT NOTICE

Texas Instruments and its subsidiaries (TI) reserve the right to make changes to their products or to discontinue any product or service without notice, and advise customers to obtain the latest version of relevant information to verify, before placing orders, that information being relied on is current and complete. All products are sold subject to the terms and conditions of sale supplied at the time of order acknowledgement, including those pertaining to warranty, patent infringement, and limitation of liability.

TI warrants performance of its semiconductor products to the specifications applicable at the time of sale in accordance with TI's standard warranty. Testing and other quality control techniques are utilized to the extent TI deems necessary to support this warranty. Specific testing of all parameters of each device is not necessarily performed, except those mandated by government requirements.

CERTAIN APPLICATIONS USING SEMICONDUCTOR PRODUCTS MAY INVOLVE POTENTIAL RISKS OF DEATH, PERSONAL INJURY, OR SEVERE PROPERTY OR ENVIRONMENTAL DAMAGE ("CRITICAL APPLICATIONS"). TI SEMICONDUCTOR PRODUCTS ARE NOT DESIGNED, AUTHORIZED, OR WARRANTED TO BE SUITABLE FOR USE IN LIFE-SUPPORT DEVICES OR SYSTEMS OR OTHER CRITICAL APPLICATIONS. INCLUSION OF TI PRODUCTS IN SUCH APPLICATIONS IS UNDERSTOOD TO BE FULLY AT THE CUSTOMER'S RISK.

In order to minimize risks associated with the customer's applications, adequate design and operating safeguards must be provided by the customer to minimize inherent or procedural hazards.

TI assumes no liability for applications assistance or customer product design. TI does not warrant or represent that any license, either express or implied, is granted under any patent right, copyright, mask work right, or other intellectual property right of TI covering or relating to any combination, machine, or process in which such semiconductor products or services might be or are used. TI's publication of information regarding any third party's products or services does not constitute TI's approval, warranty or endorsement thereof.

This datasheet has been downloaded from:

[www.DatasheetCatalog.com](http://www.DatasheetCatalog.com)

Datasheets for electronic components.

# Texas Instruments

<http://www.ti.com>

This file is the datasheet for the following electronic components:

7475 - <http://www.ti.com/product/7475?HQS=TI-null-null-dscatalog-df-pf-null-ww>

SN7475N - <http://www.ti.com/product/sn7475n?HQS=TI-null-null-dscatalog-df-pf-null-ww>

SN7475 - <http://www.ti.com/product/sn7475?HQS=TI-null-null-dscatalog-df-pf-null-ww>

SN5477W - <http://www.ti.com/product/sn5477w?HQS=TI-null-null-dscatalog-df-pf-null-ww>

SN5477 - <http://www.ti.com/product/sn5477?HQS=TI-null-null-dscatalog-df-pf-null-ww>

SN5475W - <http://www.ti.com/product/sn5475w?HQS=TI-null-null-dscatalog-df-pf-null-ww>

SN5475J - <http://www.ti.com/product/sn5475j?HQS=TI-null-null-dscatalog-df-pf-null-ww>

SN54LS77 - <http://www.ti.com/product/sn54ls77?HQS=TI-null-null-dscatalog-df-pf-null-ww>

SN54LS77W - <http://www.ti.com/product/sn54ls77w?HQS=TI-null-null-dscatalog-df-pf-null-ww>

SN54LS75W - <http://www.ti.com/product/sn54ls75w?HQS=TI-null-null-dscatalog-df-pf-null-ww>

74LS75 - <http://www.ti.com/product/74ls75?HQS=TI-null-null-dscatalog-df-pf-null-ww>



LittleDiode supplies new, hard to find or obsolete electronic components and semiconductors all over the world.

With over two million different components listed you are sure to find the part you need.

Feel free to visit us today at our online store:

[LittleDiode.com](http://LittleDiode.com)

Looking forward to providing you with the best possible service.