

DATA SHEET

74F1245

Octal transceiver (3-State)

Product specification

1995 Mar 01

IC15 Data Handbook

Philips Semiconductors



PHILIPS

Octal transceiver (3-State)

74F1245

FEATURES

- Same function and pinout as 74F245
- High impedance NPN base inputs for reduced loading (70µA in Low and High states)
- Useful in applications where light loading bus loading or direct interface with output of a MOS microprocessor is desired
- Octal bidirectional bus interface
- Glitch free during 3-State power up and power down
- 3-State buffer outputs sink 64mA and source 15mA

TYPE	TYPICAL PROPAGATION DELAY	TYPICAL SUPPLY CURRENT (TOTAL)
74F1245	5.0ns	115mA

DESCRIPTION

The 74F1245 is an octal transceiver featuring non-inverting 3-State bus compatible outputs in both transmit and receive directions. The B port outputs are capable of sinking 64mA and sourcing up to 15mA, producing very good capacitive drive characteristics. The device features an Output Enable (\overline{OE}) input for easy cascading and Transmit/Receive (T/R) input for direction control. The 3-State outputs, B0–B7, have been designed to prevent output bus loading if the power is removed from the device.

ORDERING INFORMATION

DESCRIPTION	COMMERCIAL RANGE $V_{CC} = 5V \pm 10\%$, $T_{amb} = 0^{\circ}C$ to $+70^{\circ}C$	DRAWING NUMBER
20-Pin Plastic DIP	N74F1245N	SOT146-1
20-Pin Plastic SOL	N74F1245D	SOT163-1

INPUT AND OUTPUT LOADING AND FAN-OUT TABLE

PINS	DESCRIPTION	74F (U.L.) HIGH/LOW	LOAD VALUE HIGH/LOW
A0–A7, B0–B7	A and B port inputs	3.5/0.117	70µA/70µA
\overline{OE}	Output Enable input (active Low)	2.0/0.033	40µA/20µA
T/R	Transmit/Receive input	2.0/0.033	40µA/20µA
A0–A7	A port outputs	150/40	3.0mA/24mA
B0–B7	B port outputs	750/106.7	15mA/64mA

NOTE: One (1.0) FAST unit load is defined as: 20µA in the High state and 0.6mA in the Low state.

PIN CONFIGURATION

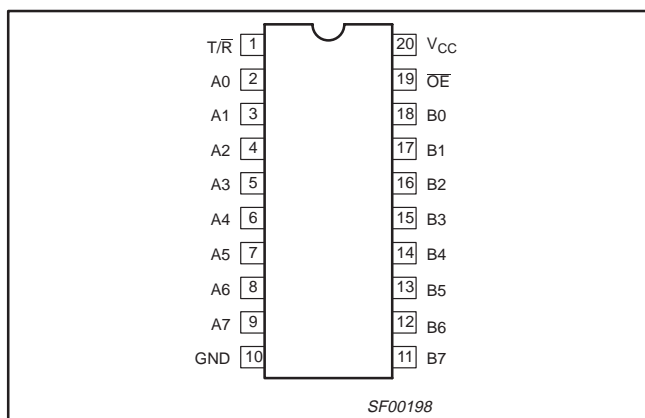

LOGIC SYMBOL

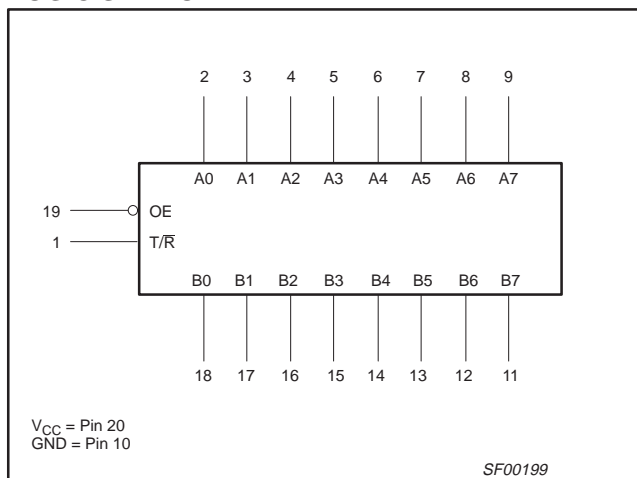

Octal transceiver (3-State)

74F1245

LOGIC SYMBOL (IEEE/IEC)

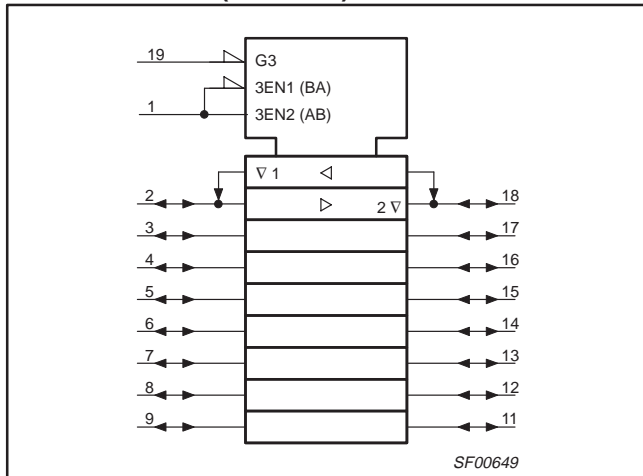

FUNCTION TABLE

INPUTS		INPUTS/OUTPUTS	
OE	T/R	A _n	B _n
L	L	A = B	INPUTS
L	H	INPUTS	B = A
H	X	Z	Z

H = High voltage level
 L = Low voltage level
 X = Don't care
 Z = High impedance "off" state

LOGIC DIAGRAM

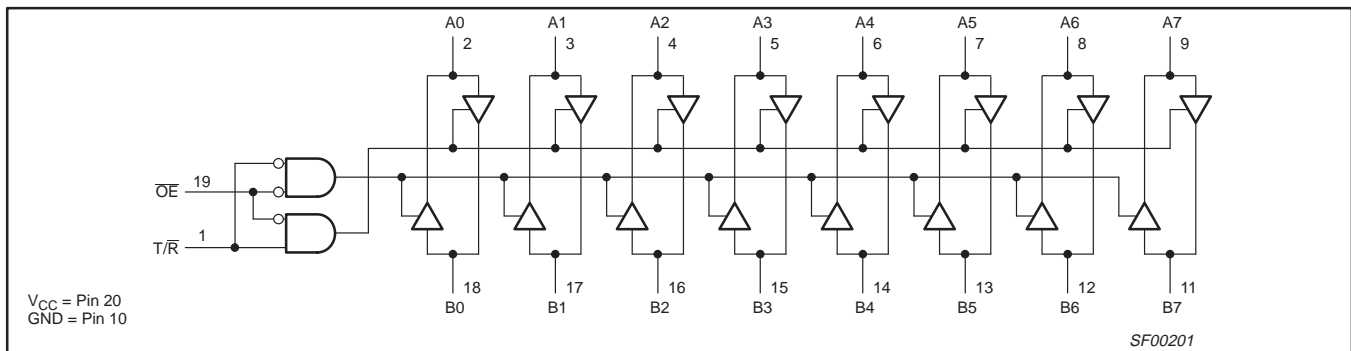

ABSOLUTE MAXIMUM RATINGS

(Operation beyond the limits set forth in this table may impair the useful life of the device. Unless otherwise noted these limits are over the operating free-air temperature range.)

SYMBOL	PARAMETER	RATING	UNIT
V _{CC}	Supply voltage	-0.5 to +7.0	V
V _{IN}	Input voltage	-0.5 to +7.0	V
I _{IN}	Input current	-30 to +5	mA
V _{OUT}	Voltage applied to output in High output state	-0.5 to +5.5	V
I _{OUT}	Current applied to output in Low output state	A0-A7	48
		B0-B7	128
T _{amb}	Operating free-air temperature range	0 to +70	°C
T _{stg}	Storage temperature range	-65 to +150	°C

Octal transceiver (3-State)

74F1245

RECOMMENDED OPERATING CONDITIONS

SYMBOL	PARAMETER	LIMITS			UNIT
		MIN	NOM	MAX	
V _{CC}	Supply voltage	4.5	5.0	5.5	V
V _{IH}	High-level input voltage	2.0			V
V _{IL}	Low-level input voltage			0.8	V
I _{IK}	Input clamp current			-18	mA
I _{OH}	High-level output current	A0–A7		-3	mA
		B0–B7		-15	mA
I _{OL}	Low-level output current	A0–A7		24	mA
		B0–B7		64	mA
T _{amb}	Operating free-air temperature range	0		70	°C

DC ELECTRICAL CHARACTERISTICS

(Over recommended operating free-air temperature range unless otherwise noted.)

SYMBOL	PARAMETER		TEST CONDITIONS ^{NO TAG}			LIMITS			UNIT
						MIN	TYP NO TAG	MAX	
V _{OH}	High-level output voltage	A0–A7, B0–B7	V _{CC} = MIN, V _{IL} = MAX, V _{IH} = MIN	I _{OH} = -3mA	±10% V _{CC}	2.4			V
					±5% V _{CC}	2.7	3.3		V
		B0–B7		I _{OH} = -15mA	±10% V _{CC}	2.0			V
					±5% V _{CC}	2.0			V
V _{OL}	Low-level output voltage	A0–A7	V _{CC} = MIN, V _{IL} = MAX, V _{IH} = MIN	I _{OL} = 24mA	±10% V _{CC}		0.35	0.50	V
					±5% V _{CC}		0.35	0.50	V
		B0–B7		I _{OL} = 48mA	±10% V _{CC}		0.30	0.55	V
					±5% V _{CC}		0.42	0.55	V
V _{IK}	Input clamp voltage		V _{CC} = MIN, I _I = I _{IK}			-0.73	-1.2	V	
I _I	Input current at maximum input voltage	\overline{OE} , T/ \overline{R}	V _{CC} = 0.0V, V _I = 7.0V				100	μA	
		A0–A7, B0–B7	V _{CC} = 0.0V, V _I = 5.5V				100	μA	
I _{IH}	High-level input current	\overline{OE} , T/ \overline{R} only	V _{CC} = MAX, V _I = 2.7V				40	μA	
I _{IL}	Low-level input current	\overline{OE} , T/ \overline{R} only	V _{CC} = MAX, V _I = 0.5V				-20	μA	
I _{IH} +I _{OZH}	Off-state output current High-level voltage applied		V _{CC} = MAX, V _O = 2.7V				70	μA	
I _{IL} +I _{OZL}	Off-state output current Low-level voltage applied		V _{CC} = MAX, V _O = 0.5V				-70	μA	
I _{OS}	Short-circuit output current ^{NO TAG}	A0–A7	V _{CC} = MAX		-60		-150	mA	
		B0–B7			-100		-225	mA	
I _{CC}	Supply current (total)	I _{CCH}	V _{CC} = MAX			120	155	mA	
		I _{CCL}				116	150	mA	
		I _{CCZ}				110	165	mA	

NOTES:

- For conditions shown as MIN or MAX, use the appropriate value specified under recommended operating conditions for the applicable type.
- All typical values are at V_{CC} = 5V, T_{amb} = 25°C.
- Not more than one output should be shorted at a time. For testing I_{OS}, the use of high-speed test apparatus and/or sample-and-hold techniques are preferable in order to minimize internal heating and more accurately reflect operational values. Otherwise, prolonged shorting of a High output may raise the chip temperature well above normal and thereby cause invalid readings in other parameter tests. In any sequence of parameter tests, I_{OS} tests should be performed last.

Octal transceiver (3-State)

74F1245

AC ELECTRICAL CHARACTERISTICS

SYMBOL	PARAMETER	TEST CONDITION	LIMITS					UNIT
			V _{CC} = +5.0V T _{amb} = +25°C C _L = 50pF, R _L = 500Ω			V _{CC} = +5.0V ± 10% T _{amb} = 0°C to +70°C C _L = 50pF, R _L = 500Ω		
			MIN	TYP	MAX	MIN	MAX	
t _{PLH} t _{PHL}	Propagation delay An to Bn, Bn to An	Waveform NO TAG	2.0 2.5	4.0 5.0	6.5 7.5	1.5 2.0	7.0 8.0	ns
t _{PZH} t _{PZL}	Output Enable time OE to An or Bn	Waveform NO TAG Waveform NO TAG	3.0 4.0	6.0 7.5	8.0 10.0	2.5 3.5	9.0 11.0	ns
t _{PHZ} t _{PLZ}	Output Disable time OE to An or Bn	Waveform NO TAG Waveform NO TAG	2.0 4.0	5.0 7.0	8.0 10.0	1.5 4.0	9.0 11.0	ns

AC WAVEFORMS

For all waveforms, V_M = 1.5V.

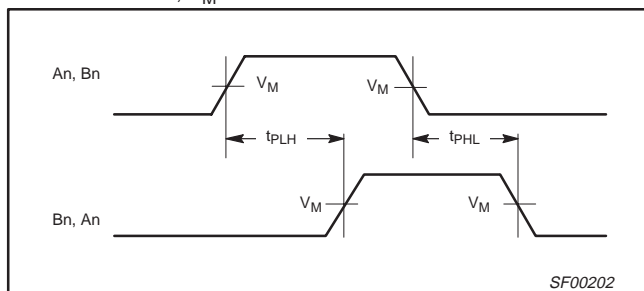

Waveform 1. Propagation Delay for Non-Inverting Output

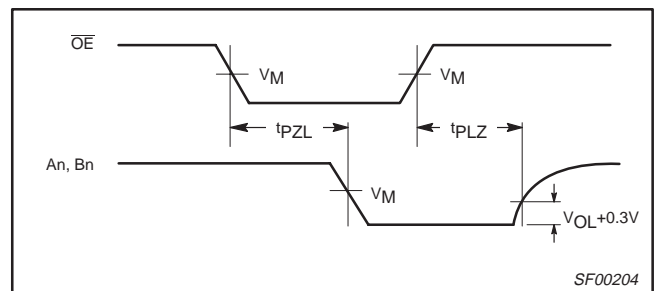

Waveform 3. 3-State Output Enable Time to Low Level and Output Disable Time from Low Level

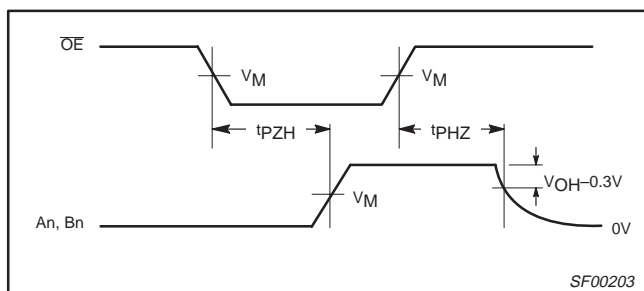

Waveform 2. 3-State Output Enable Time to High Level and Output Disable Time from High Level

Octal transceiver (3-State)

74F1245

TEST CIRCUIT AND WAVEFORMS

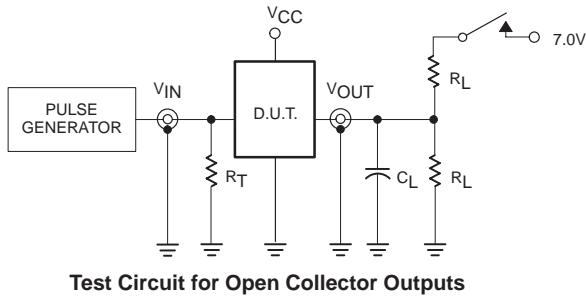

Test Circuit for Open Collector Outputs

SWITCH POSITION

TEST	SWITCH
t_{PLZ}	closed
t_{PZL}	closed
All other	open

DEFINITIONS:

- R_L = Load resistor; see AC electrical characteristics for value.
- C_L = Load capacitance includes jig and probe capacitance; see AC electrical characteristics for value.
- R_T = Termination resistance should be equal to Z_{OUT} of pulse generators.

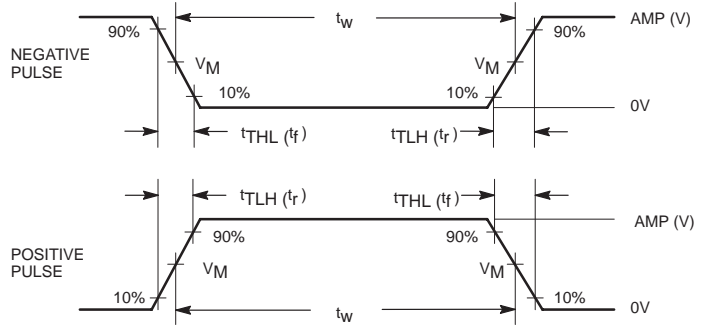

Input Pulse Definition

family	INPUT PULSE REQUIREMENTS					
	amplitude	V_M	rep. rate	t_w	t_{TLH}	t_{THL}
74F	3.0V	1.5V	1MHz	500ns	2.5ns	2.5ns

SF00128

Octal transceiver (3-State)

74F1245

DIP20: plastic dual in-line package; 20 leads (300 mil)

SOT146-1

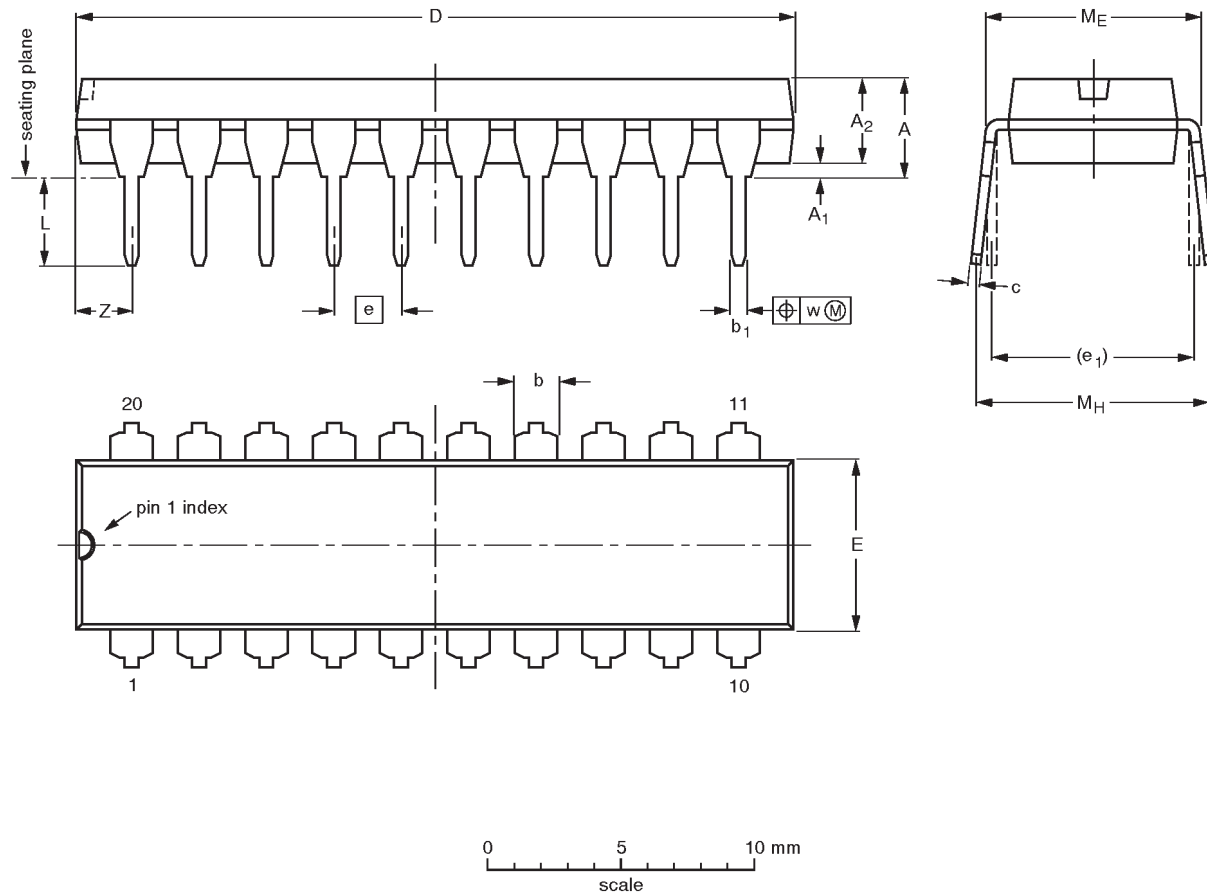

DIMENSIONS (inch dimensions are derived from the original mm dimensions)

UNIT	A max.	A ₁ min.	A ₂ max.	b	b ₁	c	D ⁽¹⁾	E ⁽¹⁾	e	e ₁	L	M _E	M _H	w	Z ⁽¹⁾ max.
mm	4.2	0.51	3.2	1.73 1.30	0.53 0.38	0.36 0.23	26.92 26.54	6.40 6.22	2.54	7.62	3.60 3.05	8.25 7.80	10.0 8.3	0.254	2.0
inches	0.17	0.020	0.13	0.068 0.051	0.021 0.015	0.014 0.009	1.060 1.045	0.25 0.24	0.10	0.30	0.14 0.12	0.32 0.31	0.39 0.33	0.01	0.078

Note

1. Plastic or metal protrusions of 0.25 mm maximum per side are not included.

OUTLINE VERSION	REFERENCES				EUROPEAN PROJECTION	ISSUE DATE
	IEC	JEDEC	EIAJ			
SOT146-1			SC603			92-11-17 95-05-24

Octal transceiver (3-State)

74F1245

SO20: plastic small outline package; 20 leads; body width 7.5 mm

SOT163-1

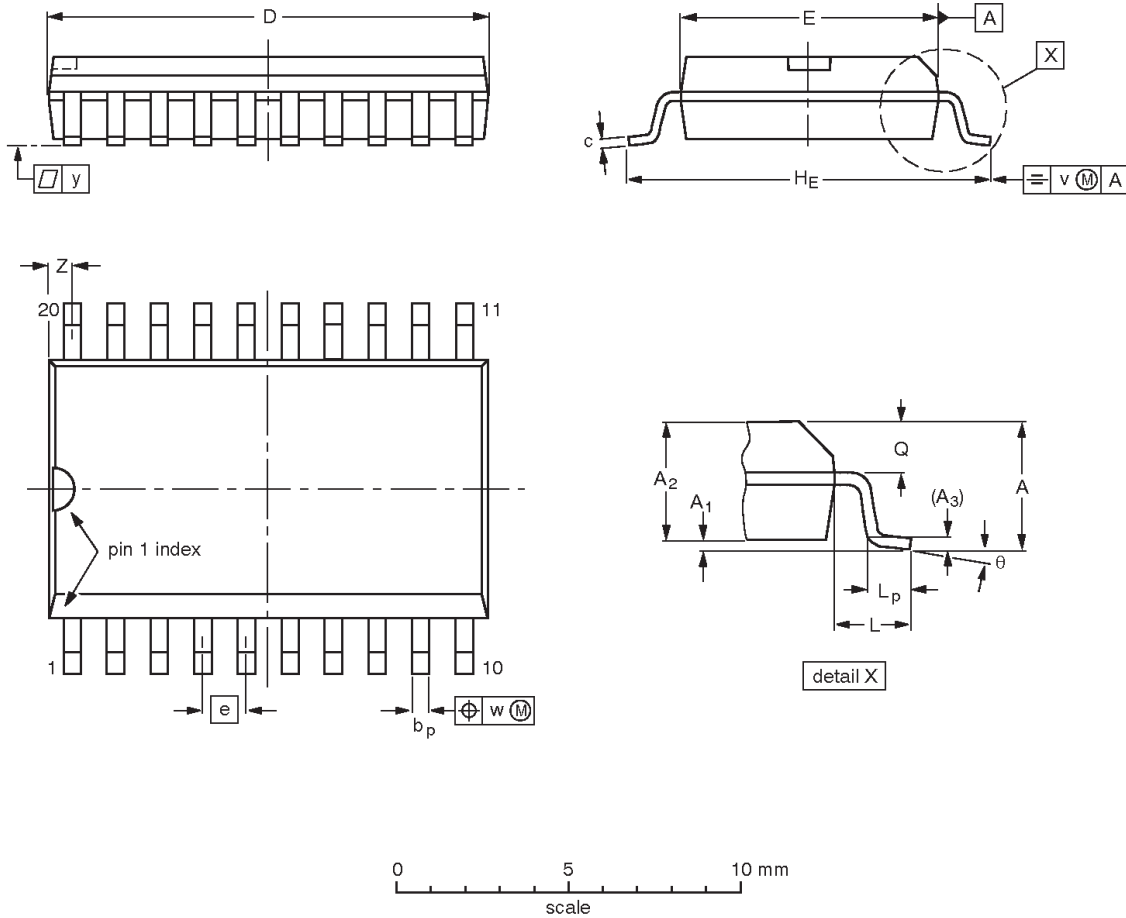

DIMENSIONS (inch dimensions are derived from the original mm dimensions)

UNIT	A max.	A ₁	A ₂	A ₃	b _p	c	D ⁽¹⁾	E ⁽¹⁾	e	HE	L	L _p	Q	v	w	y	Z ⁽¹⁾	θ
mm	2.65	0.30 0.10	2.45 2.25	0.25	0.49 0.36	0.32 0.23	13.0 12.6	7.6 7.4	1.27	10.65 10.00	1.4	1.1 0.4	1.1 1.0	0.25	0.25	0.1	0.9 0.4	8° 0°
inches	0.10	0.012 0.004	0.096 0.089	0.01	0.019 0.014	0.013 0.009	0.51 0.49	0.30 0.29	0.050	0.419 0.394	0.055	0.043 0.016	0.043 0.039	0.01	0.01	0.004	0.035 0.016	

Note

1. Plastic or metal protrusions of 0.15 mm maximum per side are not included.

OUTLINE VERSION	REFERENCES				EUROPEAN PROJECTION	ISSUE DATE
	IEC	JEDEC	EIAJ			
SOT163-1	075E04	MS-013AC				95-01-24 97-05-22

Octal transceiver (3-State)

74F1245

NOTES

Octal transceiver (3-State)

74F1245

DEFINITIONS

Data Sheet Identification	Product Status	Definition
<i>Objective Specification</i>	Formative or in Design	This data sheet contains the design target or goal specifications for product development. Specifications may change in any manner without notice.
<i>Preliminary Specification</i>	Preproduction Product	This data sheet contains preliminary data, and supplementary data will be published at a later date. Philips Semiconductors reserves the right to make changes at any time without notice in order to improve design and supply the best possible product.
<i>Product Specification</i>	Full Production	This data sheet contains Final Specifications. Philips Semiconductors reserves the right to make changes at any time without notice, in order to improve design and supply the best possible product.

Philips Semiconductors and Philips Electronics North America Corporation reserve the right to make changes, without notice, in the products, including circuits, standard cells, and/or software, described or contained herein in order to improve design and/or performance. Philips Semiconductors assumes no responsibility or liability for the use of any of these products, conveys no license or title under any patent, copyright, or mask work right to these products, and makes no representations or warranties that these products are free from patent, copyright, or mask work right infringement, unless otherwise specified. Applications that are described herein for any of these products are for illustrative purposes only. Philips Semiconductors makes no representation or warranty that such applications will be suitable for the specified use without further testing or modification.

LIFE SUPPORT APPLICATIONS

Philips Semiconductors and Philips Electronics North America Corporation Products are not designed for use in life support appliances, devices, or systems where malfunction of a Philips Semiconductors and Philips Electronics North America Corporation Product can reasonably be expected to result in a personal injury. Philips Semiconductors and Philips Electronics North America Corporation customers using or selling Philips Semiconductors and Philips Electronics North America Corporation Products for use in such applications do so at their own risk and agree to fully indemnify Philips Semiconductors and Philips Electronics North America Corporation for any damages resulting from such improper use or sale.

Philips Semiconductors
811 East Arques Avenue
P.O. Box 3409
Sunnyvale, California 94088-3409
Telephone 800-234-7381

Philips Semiconductors and Philips Electronics North America Corporation register eligible circuits under the Semiconductor Chip Protection Act.
 © Copyright Philips Electronics North America Corporation 1995
 All rights reserved. Printed in U.S.A.



LittleDiode supplies new, hard to find or obsolete electronic components and semiconductors all over the world.

With over two million different components listed you are sure to find the part you need.

Feel free to visit us today at our online store:

LittleDiode.com

Looking forward to providing you with the best possible service.