



μ A78S40

Universal Switching Regulator Subsystem

The μ A78S40 is a switching regulator subsystem, consisting of a temperature compensated voltage reference, controlled-duty cycle oscillator with an active current limit circuit, comparator, high-current and high-voltage output switch, capable of 1.5 A and 40 V, pinned-out power diode and an uncommitted operational amplifier, which can be powered up or down independent of the IC supply. The switching output can drive external NPN or PNP transistors when voltages greater the 40 V, or currents in excess of 1.5 A, are required. Some of the features are wide-supply voltage range, low standby current, high efficiency and low drift. The μ A78S40 is available in commercial (0° to + 70°C), and automotive (-40° to + 85°C) temperature ranges.

Some of the applications include use in step-up, step-down, and inverting regulators, with extremely good results obtained in battery-operated systems.

- Output Adjustable from 1.25 V to 40 V
- Peak Output Current of 1.5 A Without External Transistor
- 80 dB Line and Load Regulation
- Operation from 2.5 V to 40 V Supply
- Low Standby Current Drain
- High Gain, High Output Current, Uncommitted Op Amp

UNIVERSAL SWITCHING REGULATOR SUBSYSTEM

SEMICONDUCTOR TECHNICAL DATA

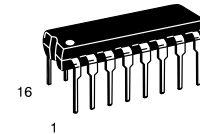

P SUFFIX
PLASTIC PACKAGE
CASE 648

Simplified Block Diagram

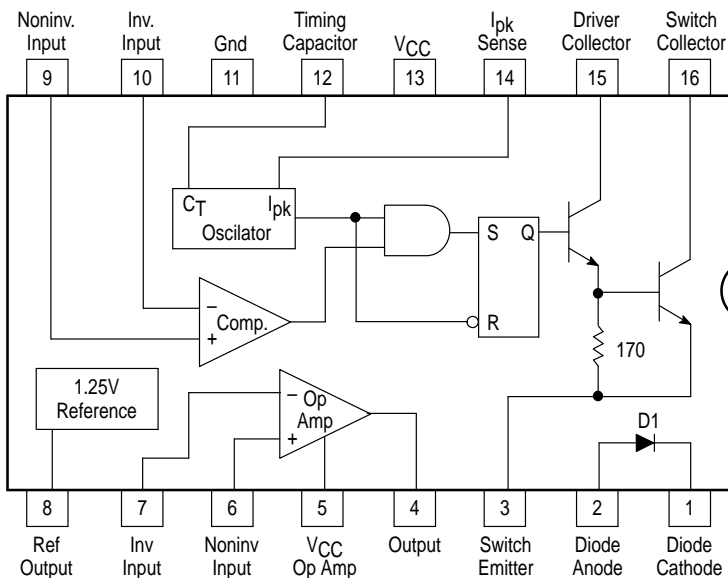

(Bottom View)

PIN CONNECTIONS

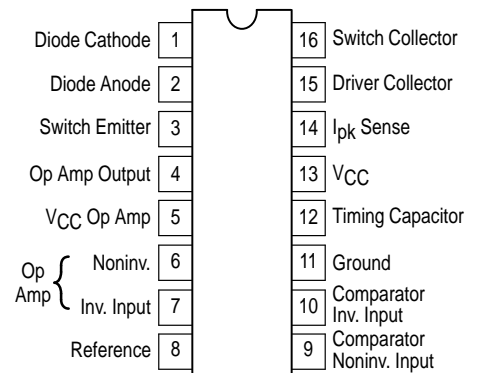

(Top View)

ORDERING INFORMATION

Device	Temperature Range	Package
μ A78S40PC	$T_A = 0^\circ \text{ to } +70^\circ\text{C}$	Plastic
μ A78S40PV	$T_A = -40^\circ \text{ to } +85^\circ\text{C}$	Plastic

μA78S40

MAXIMUM RATINGS

Rating	Symbol	Value	Unit
Power Supply Voltage	V_{CC}	40	V
Op Amp Power Supply Voltage	V_{CC} (Op Amp)	40	V
Common Mode Input Range (Comparator and Op Amp)	V_{ICR}	-0.3 to V_{CC}	V
Differential Input Voltage (Note 2)	V_{ID}	± 30	V
Output Short Circuit Duration (Op Amp)		Continuous	–
Reference Output Current	I_{ref}	10	mA
Voltage from Switch Collectors to Gnd		40	V
Voltage from Switch Emitters to Gnd		40	V
Voltage from Switch Collectors to Emitter		40	V
Voltage from Power Diode to Gnd		40	V
Reverse–Power Diode Voltage	V_{DR}	40	V
Current through Power Switch	I_{SW}	1.5	A
Current through Power Diode	I_D	1.5	A
Power Dissipation and Thermal Characteristics: Plastic Package ($T_A = +25^\circ\text{C}$) Derate above $+25^\circ\text{C}$ (Note 1)	P_D 1/ $R_{\theta JA}$	1500 14	mW mW/ $^\circ\text{C}$
Storage Temperature Range	T_{stg}	-65 to + 150	$^\circ\text{C}$
Operating Temperature Range μA78S40V μA78S40C	T_A	-40 to +85 0 to +70	$^\circ\text{C}$

- NOTES:** 1. $T_{low} = -40^\circ$ for μA78S40PV
 $T_{high} = +85^\circ$ for μA78S40PV
 $= 0^\circ$ for μA78S40PC
 $= +70^\circ$ for μA78S40PC
 2. For supply voltages less than 30 V the maximum differential input voltage (Error Amp and Op Amp) is equal to the supply voltage.

ELECTRICAL CHARACTERISTICS ($V_{CC} = V_{CC}$ (Op Amp) 5.0 V, $T_A = T_{low}$ to T_{high} , unless otherwise noted.)

Characteristic	Symbol	Min	Typ	Max	Unit
GENERAL					
Supply Voltage	V_{CC}	2.5	–	40	V
Supply Current (Op Amp V_{CC} , disconnected) ($V_{CC} = 5.0$ V) ($V_{CC} = 40$ V)	I_{CC}	– –	1.8 2.3	3.5 5.0	mA
Supply Current (Op Amp V_{CC} , connected) ($V_{CC} = 5.0$ V) ($V_{CC} = 40$ V)	I_{CC}	– –	– –	4.0 5.5	mA
REFERENCE					
Reference Voltage ($I_{ref} = 1.0$ mA)	V_{ref}	1.180	1.245	1.310	V
Reference Voltage Line Regulation (3.0 V $\leq V_{CC} \leq 40$ V, $I_{ref} = 1.0$ mA, $T_A = 25^\circ\text{C}$)	Reg_{line}	–	0.04	0.2	mV/V
Reference Voltage Load Regulation (1.0 mA $\leq I_{ref} \leq 10$ mA, $T_A = 25^\circ\text{C}$)	Reg_{load}	–	0.2	0.5	mV/mA

μA78S40

ELECTRICAL CHARACTERISTICS ($V_{CC} = V_{CC} \text{ (Op Amp)}$ 5.0 V, $T_A = T_{\text{low}}$ to T_{high} , unless otherwise noted.)

Characteristic	Symbol	Min	Typ	Max	Unit
OSCILLATOR					
Charging Current ($T_A = 25^\circ\text{C}$) ($V_{CC} = 5.0 \text{ V}$) ($V_{CC} = 40 \text{ V}$)	I_{chg}	20 20	– –	50 70	μA
Discharging Current ($T_A = 25^\circ\text{C}$) ($V_{CC} = 5.0 \text{ V}$) ($V_{CC} = 40 \text{ V}$)	I_{dis}	150 150	– –	250 350	μA
Oscillator Voltage Swing ($T_A = 25^\circ\text{C}$) ($V_{CC} = 5.0 \text{ V}$)	V_{osc}	–	0.5	–	V
Ratio of Charge/Discharge Time	$t_{\text{chg}}/t_{\text{dis}}$	–	6.0	–	–

CURRENT LIMIT

Current–Limit Sense Voltage ($T_A = 25^\circ\text{C}$) ($V_{CC} - V_{\text{Ipk}}$ Sense)	V_{CLS}	250	–	350	mV
--	------------------	-----	---	-----	----

OUTPUT SWITCH

Output Saturation Voltage 1 ($I_{\text{SW}} = 1.0 \text{ A}$, Pin 15 tied to Pin 16)	V_{sat1}	–	0.93	1.3	V
Output Saturation Voltage 2 ($I_{\text{SW}} = 1.0 \text{ A}$, $I_{15} = 50 \text{ mA}$)	V_{sat2}	–	0.5	0.7	V
Output Transistor Current Gain ($T_A = 25^\circ\text{C}$) ($I_C = 1.0 \text{ A}$, $V_{\text{CE}} = 5.0 \text{ V}$)	h_{FE}	–	70	–	–
Output Leakage Current ($T_A = 25^\circ\text{C}$) ($V_{\text{CE}} = 40 \text{ V}$)	$I_{\text{C(off)}}$	–	10	–	nA

POWER DIODE

Forward Voltage Drop ($I_D = 1.0 \text{ A}$)	V_D	–	1.25	1.5	V
Diode Leakage Current ($T_A = 25^\circ\text{C}$) ($V_{\text{DR}} = 40 \text{ V}$)	I_{DR}	–	10	–	nA

COMPARATOR

Input Offset Voltage ($V_{\text{CM}} = V_{\text{ref}}$)	V_{IO}	–	1.5	15	mV
Input Bias Current ($V_{\text{CM}} = V_{\text{ref}}$)	I_{IB}	–	35	200	nA
Input Offset Current ($V_{\text{CM}} = V_{\text{ref}}$)	I_{IO}	–	5.0	75	nA
Common Mode Voltage Range ($T_A = 25^\circ\text{C}$)	V_{ICR}	0	–	$V_{\text{CC}} - 2.0$	V
Power–Supply Rejection Ratio ($T_A = 25^\circ\text{C}$) ($3.0 \leq V_{\text{CC}} \leq 40 \text{ V}$)	PSRR	70	96	–	dB

OUTPUT OPERATION AMPLIFIER

Input Offset Voltage ($V_{\text{CM}} = 2.5 \text{ V}$)	V_{IO}	–	4.0	15	mV
Input Bias Current ($V_{\text{CM}} = 2.5 \text{ V}$)	I_{IB}	–	30	200	nA
Input Offset Current ($V_{\text{CM}} = 2.5 \text{ V}$)	I_{IO}	–	5.0	75	nA
Voltage Gain + ($T_A = 25^\circ\text{C}$) ($R_L = 2.0 \text{ k}\Omega$ to Gnd, $1.0 \text{ V} \leq V_O \leq 2.5 \text{ V}$)	$A_{\text{VOL+}}$	25	250	–	V/mV
Voltage Gain – ($T_A = 25^\circ\text{C}$) ($R_L = 2.0 \text{ k}\Omega$ to V_{CC} (Op Amp), $1.0 \text{ V} \leq V_O \leq 2.5 \text{ V}$)	$A_{\text{VOL-}}$	25	250	–	V/mV
Common Mode Voltage Range ($T_A = 25^\circ\text{C}$)	V_{ICR}	0	–	$V_{\text{CC}} - 2.0$	V
Common Mode Rejection Ratio ($T_A = 25^\circ\text{C}$) ($V_{\text{CM}} = 0 \text{ V}$ to 3.0 V)	CMRR	76	100	–	dB
Power–Supply Rejection Ratio ($T_A = 25^\circ\text{C}$) ($3.0 \text{ V} \leq V_{\text{CC}}$ (Op Amp) $\leq 40 \text{ V}$)	PSRR	76	100	–	dB
Output Source Current ($T_A = 25^\circ\text{C}$)	I_{Source}	75	150	–	mA
Output Sink Current ($T_A = 25^\circ\text{C}$)	I_{Sink}	10	35	–	mA
Slew Rate ($T_A = 25^\circ\text{C}$)	SR	–	0.6	–	V/ μs
Output Low Voltage ($T_A = 25^\circ\text{C}$, $I_L = -5.0 \text{ mA}$)	V_{OL}	–	–	1.0	V
Output High Voltage ($T_A = 25^\circ\text{C}$, $I_L = 50 \text{ mA}$)	V_{OH}	V_{CC} (Op Amp) – 3.0	–	–	V

Figure 1. Output Switch On/Off Time versus Oscillator Timing Capacitor

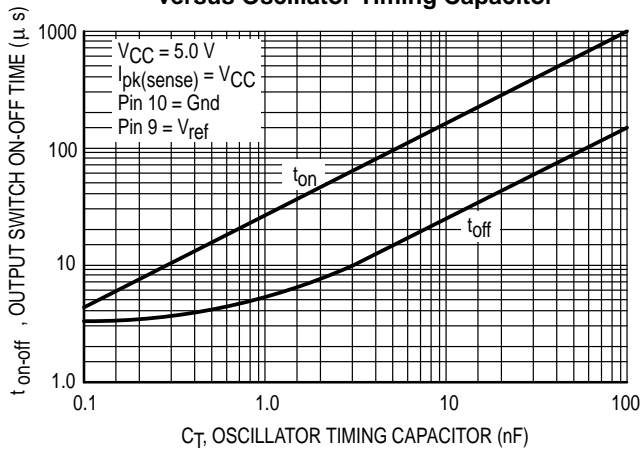

Figure 2. Standby Supply Current versus Supply Voltage

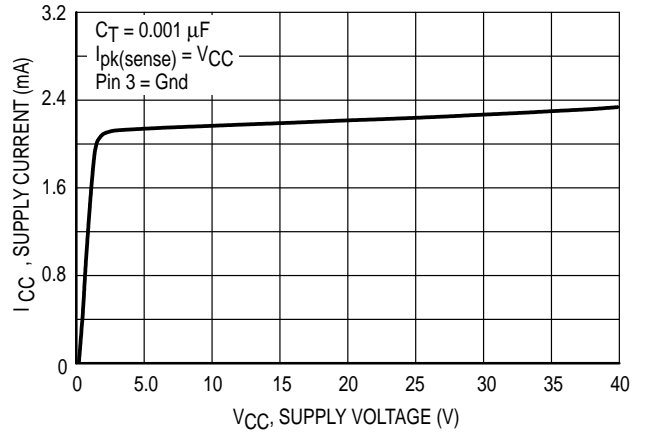

Figure 3. Emitter-Follower Configuration Output Switch Saturation Voltage versus Emitter Current

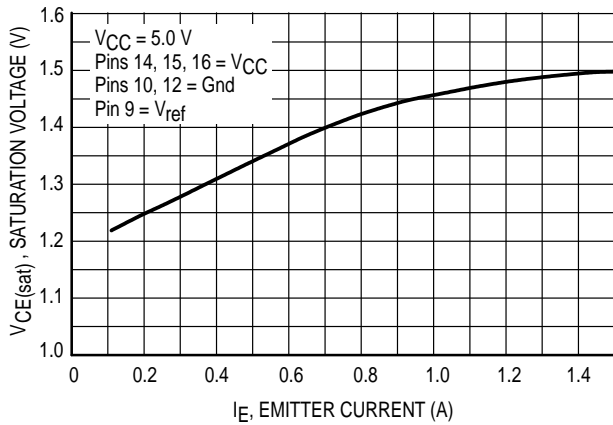
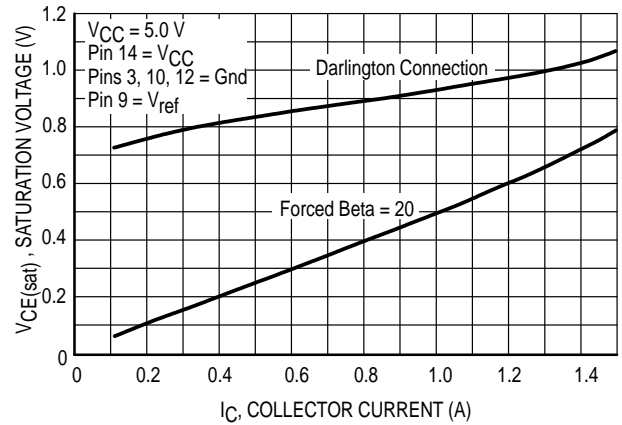

Figure 4. Common-Emitter Configuration Output Switch Saturation Voltage versus Collector Current



μA78S40

Figure 5. Step-Down Converter

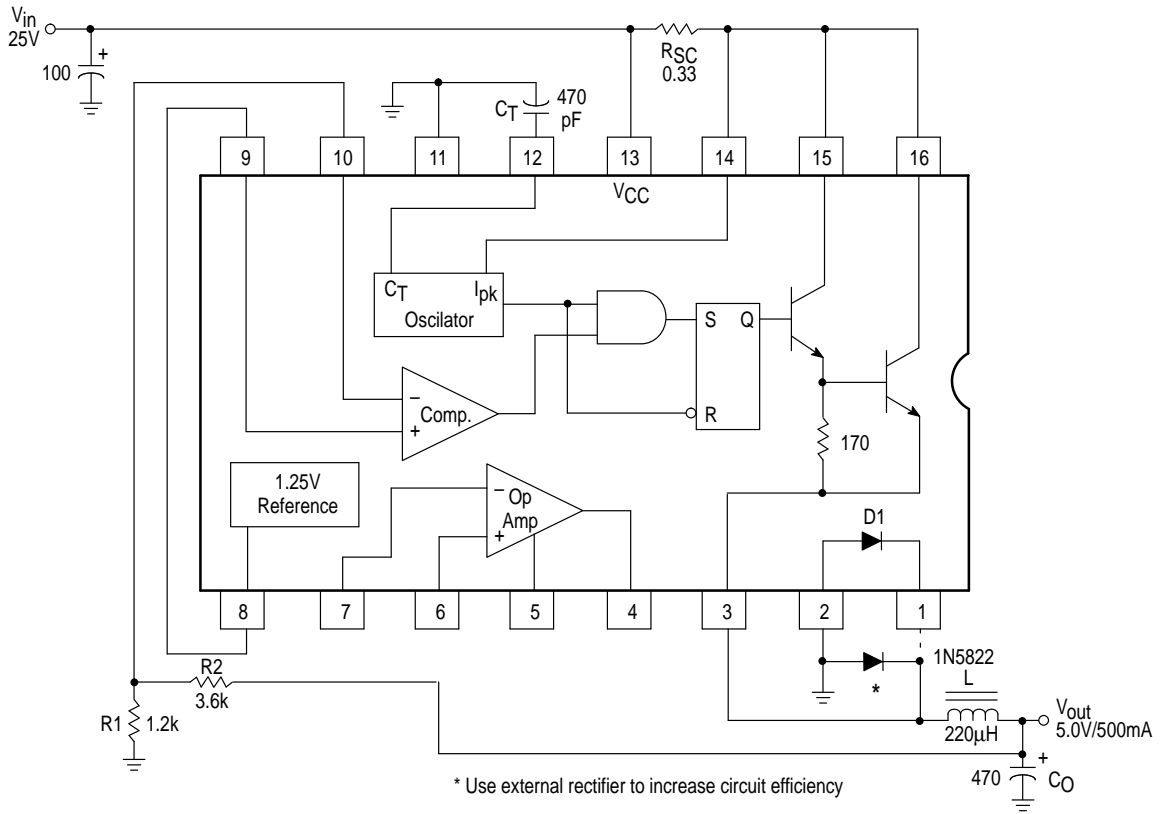
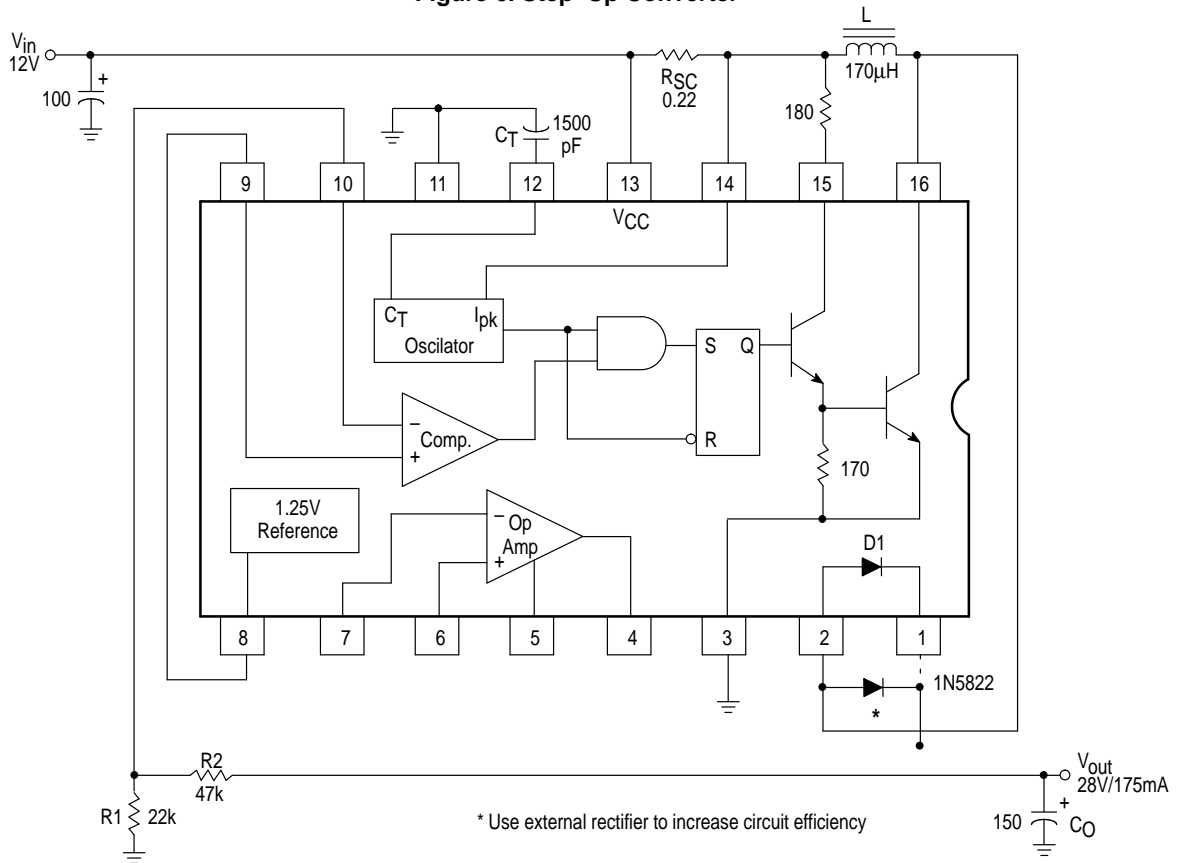
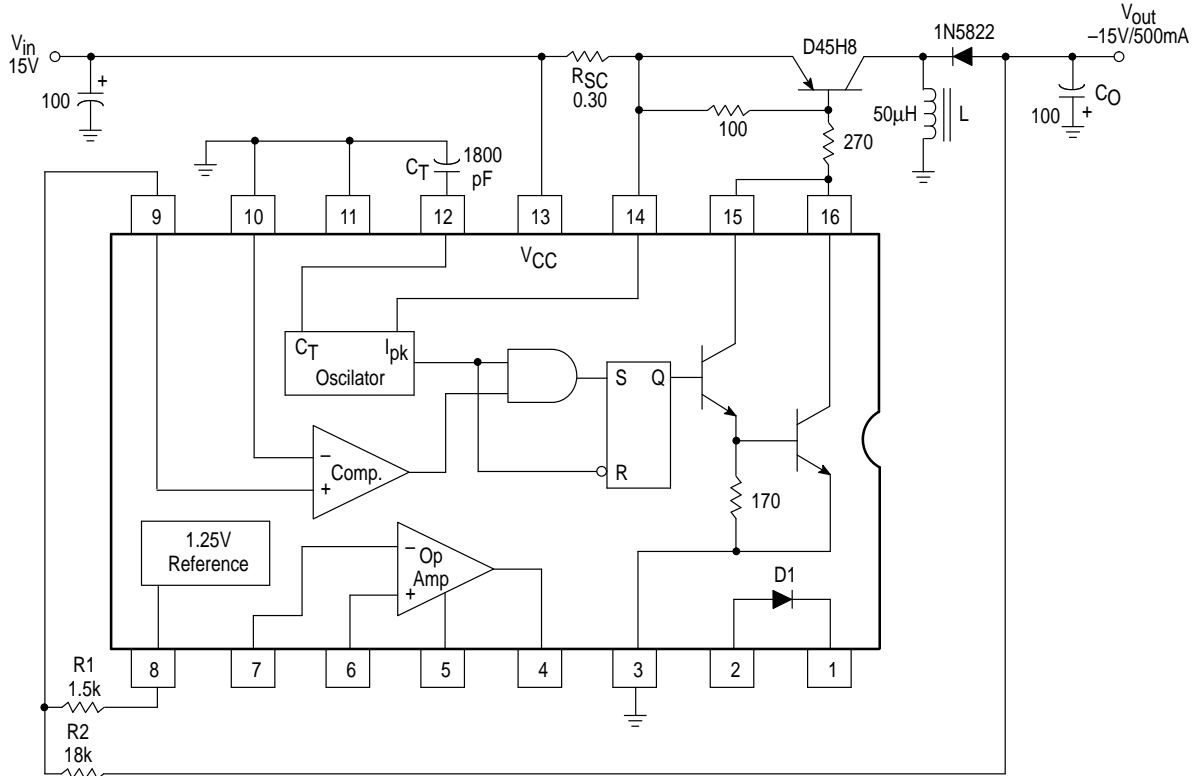

Figure 6. Step-Up Converter



μA78S40

Figure 7. Inverting Converter



Design Formula Table

Calculation	Step-Down	Step-Up	Inverting
$\frac{t_{on}}{t_{off}}$	$\frac{V_{out} + V_F}{V_{in(min)} - V_{sat} - V_{out}}$	$\frac{V_{out} - V_F}{V_{in(min)} - V_{sat}}$	$\frac{V_{out} + V_F}{V_{in(min)} - V_{sat}}$
$(t_{on} + t_{off})_{max}$	$\frac{1}{f_{min}}$	$\frac{1}{f_{min}}$	$\frac{1}{f_{min}}$
C_T	$4 \times 10^5 t_{on}$	$4 \times 10^5 t_{on}$	$4 \times 10^5 t_{on}$
$I_{pk(switch)}$	$2 I_{out(max)}$	$2 I_{out(max)} \left(\frac{t_{on} - t_{off}}{t_{off}} \right)$	$2 I_{out(max)} \left(\frac{t_{on} + t_{off}}{t_{off}} \right)$
R_{SC}	$\frac{0.33}{I_{pk(switch)}}$	$\frac{0.33}{I_{pk(switch)}}$	$\frac{0.33}{I_{pk(switch)}}$
$L_{(min)}$	$\left(\frac{V_{in(min)} - V_{sat} - V_{out}}{I_{pk(switch)}} \right) t_{on(max)}$	$\left(\frac{V_{in(min)} - V_{sat}}{I_{pk(switch)}} \right) t_{on(max)}$	$\left(\frac{V_{in(min)} - V_{sat}}{I_{pk(switch)}} \right) t_{on(max)}$
C_O	$\frac{I_{pk(switch)} (t_{on} + t_{off})}{8 V_{ripple(pp)}}$	$\approx \frac{I_{out} t_{on}}{V_{ripple}}$	$\approx \frac{I_{out} t_{on}}{V_{ripple}}$

V_{sat} = Saturation voltage of the output switch. V_F = Forward voltage drop of the ringback rectifier.

The following power supply characteristics must be chosen:

V_{in} – Nominal input voltage. If this voltage is not constant, then use $V_{in(max)}$ for step-down and $V_{in(min)}$ for step-up and inverting converter.

V_{out} – Desired output voltage: $V_{out} = 1.25 \left(1 + \frac{R_2}{R_1} \right)$ for step-down and step-up: $V_{out} = \frac{1.25 R_2}{R_1}$ for inverting.

I_{out} – Desired output current.

f_{min} – Minimum desired output switching frequency at the selected values for V_{in} and I_O .

Ripple(pp) – Desired peak-to-peak output ripple voltage. In practice, the calculated value will need to be increased due to the capacitor's equivalent series resistance and board layout. The ripple voltage should be kept to a low value since it will directly effect the line and load regulation.

See Application Note AN920 for further information

μA78S40

OUTLINE DIMENSIONS

P SUFFIX
PLASTIC PACKAGE
CASE 648-08
ISSUE R

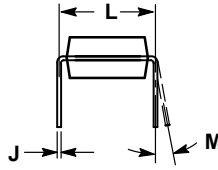
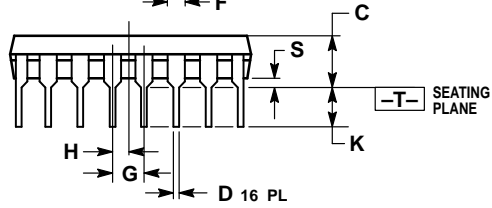
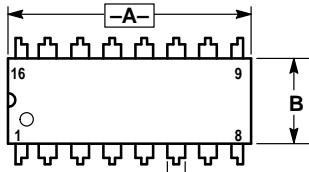

⊕ 0.25 (0.010) Ⓜ T A Ⓜ

NOTES:

1. DIMENSIONING AND TOLERANCING PER ANSI Y14.5M, 1982.
2. CONTROLLING DIMENSION: INCH.
3. DIMENSION L TO CENTER OF LEADS WHEN FORMED PARALLEL.
4. DIMENSION B DOES NOT INCLUDE MOLD FLASH.
5. ROUNDED CORNERS OPTIONAL.

DIM	INCHES		MILLIMETERS	
	MIN	MAX	MIN	MAX
A	0.740	0.770	18.80	19.55
B	0.250	0.270	6.35	6.85
C	0.145	0.175	3.69	4.44
D	0.015	0.021	0.39	0.53
F	0.040	0.70	1.02	1.77
G	0.100 BSC		2.54 BSC	
H	0.050 BSC		1.27 BSC	
J	0.008	0.015	0.21	0.38
K	0.110	0.130	2.80	3.30
L	0.295	0.305	7.50	7.74
M	0°	10°	0°	10°
S	0.020	0.040	0.51	1.01

μA78S40

Motorola reserves the right to make changes without further notice to any products herein. Motorola makes no warranty, representation or guarantee regarding the suitability of its products for any particular purpose, nor does Motorola assume any liability arising out of the application or use of any product or circuit, and specifically disclaims any and all liability, including without limitation consequential or incidental damages. "Typical" parameters which may be provided in Motorola data sheets and/or specifications can and do vary in different applications and actual performance may vary over time. All operating parameters, including "Typicals" must be validated for each customer application by customer's technical experts. Motorola does not convey any license under its patent rights nor the rights of others. Motorola products are not designed, intended, or authorized for use as components in systems intended for surgical implant into the body, or other applications intended to support or sustain life, or for any other application in which the failure of the Motorola product could create a situation where personal injury or death may occur. Should Buyer purchase or use Motorola products for any such unintended or unauthorized application, Buyer shall indemnify and hold Motorola and its officers, employees, subsidiaries, affiliates, and distributors harmless against all claims, costs, damages, and expenses, and reasonable attorney fees arising out of, directly or indirectly, any claim of personal injury or death associated with such unintended or unauthorized use, even if such claim alleges that Motorola was negligent regarding the design or manufacture of the part. Motorola and  registered trademarks of Motorola, Inc. Motorola, Inc. is an Equal Opportunity/Affirmative Action Employer.

How to reach us:

USA/EUROPE/Locations Not Listed: Motorola Literature Distribution;
P.O. Box 20912; Phoenix, Arizona 85036. 1-800-441-2447 or 602-303-5454

MFAX: RMFAX0@email.sps.mot.com – TOUCHTONE 602-244-6609
INTERNET: <http://Design-NET.com>

JAPAN: Nippon Motorola Ltd.; Tatsumi-SPD-JLDC, 6F Seibu-Butsuryu-Center,
3-14-2 Tatsumi Koto-Ku, Tokyo 135, Japan. 03-81-3521-8315

ASIA/PACIFIC: Motorola Semiconductors H.K. Ltd.; 8B Tai Ping Industrial Park,
51 Ting Kok Road, Tai Po, N.T., Hong Kong. 852-26629298



μA78S40/D



This datasheet has been downloaded from:

www.DatasheetCatalog.com

Datasheets for electronic components.



LittleDiode supplies new, hard to find or obsolete electronic components and semiconductors all over the world.

With over two million different components listed you are sure to find the part you need.

Feel free to visit us today at our online store:

LittleDiode.com

Looking forward to providing you with the best possible service.