

8086

16-Bit Microprocessor
iAPX86 Family
FINAL

DISTINCTIVE CHARACTERISTICS

- Directly addresses up to 1 Mbyte of memory
- 24 operand addressing modes
- Efficient implementation of high level languages
- Instruction set compatible with 8080 software
- Bit, byte, word, and block operations
- 8 and 16-bit signed and unsigned arithmetic in binary or decimal
- MULTIBUS[®] system interface
- Three speed options
 - 5MHz for 8086
 - 8MHz for 8086-2
 - 10MHz for 8086-1

GENERAL DESCRIPTION

The 8086 is a general purpose 16-bit microprocessor CPU. Its architecture is built around thirteen 16-bit registers and nine 1-bit flags. The CPU operates on 16-bit address spaces and can directly address up to 1 megabyte using offset addresses within four distinct memory segments, designated as code, data, stack and extra code. The 8086 implements a powerful instruction set with 24 operand addressing modes. This instruction set is compatible with that of the 8080 and 8085. In addition, the 8086 is particularly effective in executing high level languages.

The 8086 can operate in minimum and maximum modes. Maximum mode offloads certain bus control functions to a peripheral device and allows the CPU to operate efficiently in a multi-processor system. The CPU and its high performance peripherals are MULTIBUS compatible. The 8086 is implemented in N-channel, depletion load, silicon gate technology and is contained in a 40-pin CERDIP package, Molded DIP package, or Plastic Leaded Chip Carrier.

BLOCK DIAGRAM

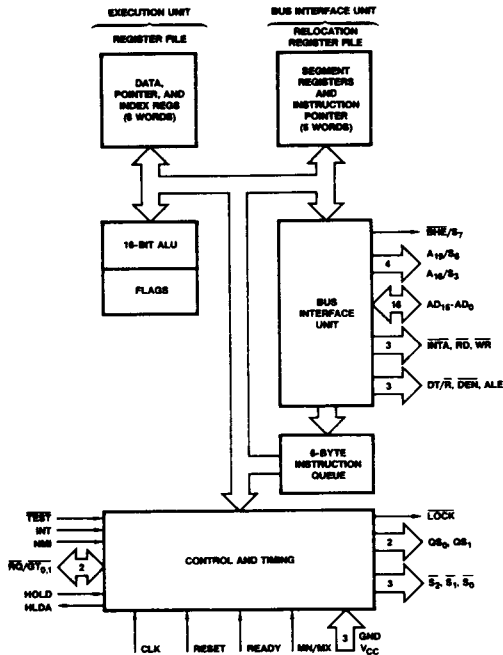

BD003740

ORDERING INFORMATION

Commercial Products

AMD commercial products are available in several packages and operating ranges. The order number (Valid Combination) is formed by a combination of:

- a. Temperature Range
- b. Package Type
- c. Device Number
- d. Speed Option
- e. Optional Processing

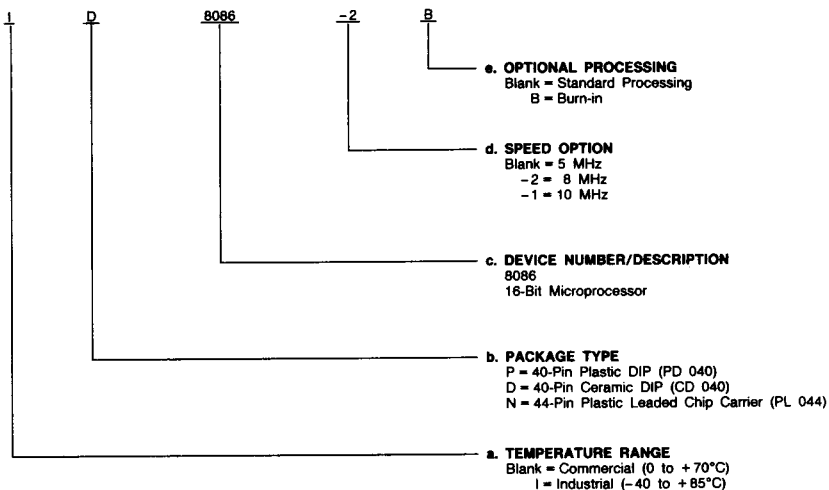

| Valid Combinations | |
|--------------------|---------|
| P, D, N | 8086 |
| | 8086-2 |
| | 8086-1 |
| D, ID | 8086-2B |
| D | 8086-1 |
| ID | 8086B |

Valid Combinations

Valid Combinations list configurations planned to be supported in volume for this device. Consult the local AMD sales office to confirm availability of specific valid combinations, to check on newly released valid combinations, and to obtain additional data on AMD's standard military grade products.

ORDERING INFORMATION

Military Products

AMD products for Aerospace and Defense applications are available in several packages and operating ranges. APL (Approved Products List) products are fully compliant with MIL-STD-883C requirements. The order number (Valid Combination) for APL products is formed by a combination of:

- a. Device Number
- b. Speed Option (if applicable)
- c. Device Class
- d. Package Type
- e. Lead Finish

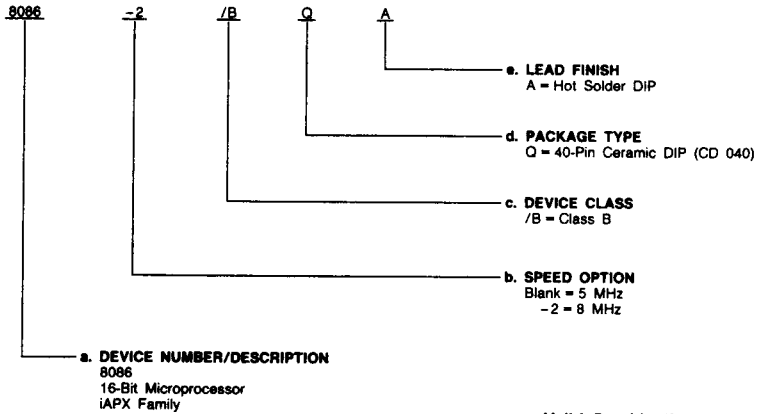

| Valid Combinations | |
|--------------------|------|
| 8086 | /BQA |
| 8086-2 | |

Valid Combinations

Valid Combinations list configurations planned to be supported in volume for this device. Consult the local AMD sales office to confirm availability of specific valid combinations or to check for newly released valid combinations.

Group A Tests

Group A tests consist of Subgroups
1, 2, 3, 7, 8, 9, 10, 11.

PIN DESCRIPTION

The following pin function descriptions are for 8086 systems in either minimum or maximum mode. The "Local Bus" in these descriptions is the direct multiplexed bus interface connection to the 8086 (without regard to additional bus buffers).

| Pin No.* | Name | I/O | Description | | | | | | | | | | | | | | | | | | |
|---------------------------------|--|-------------------------------------|---|---------------------------------|---------------------------------|-----------------|---------|---|----------------|---|---|------------------------------------|----------|---|-------------------------------------|---|---|------|---------------------------|--|--|
| 39, 2-16 | AD ₁₅ -AD ₀ | I/O | Address/Data Bus. These lines constitute the time multiplexed memory/I/O address (T ₁) and data (T ₂ , T ₃ , T _W , T ₄) bus. A ₀ is analogous to BHE for the lower byte of the data bus, pins D ₇ -D ₀ . It is LOW during T ₁ when a byte is to be transferred on the lower portion of the bus in memory or I/O operations. Eight-bit oriented devices tied to the lower half would normally use A ₀ to condition chip select functions. (See BHE.) These lines are active HIGH and float to three-state OFF during interrupt acknowledge and local bus "hold acknowledge." | | | | | | | | | | | | | | | | | | |
| 35-38 | A ₁₉ /S ₆ , A ₁₈ /S ₅ , A ₁₇ /S ₄ , A ₁₆ /S ₃ | O | Address/Status. During T ₁ these are the four most significant address lines for memory operations. During I/O operations these lines are LOW. During memory and I/O operations, status information is available on these lines during T ₂ , T ₃ , T _W , and T ₄ . The status of the interrupt enable FLAG bit (S ₅) is updated at the beginning of each CLK cycle. A ₁₇ /S ₄ and A ₁₆ /S ₃ are encoded as shown. This information indicates which relocation register is presently being used for data accessing. These lines float to three-state OFF during local bus "hold acknowledge." | | | | | | | | | | | | | | | | | | |
| | | | <table border="1" style="margin-left: auto; margin-right: auto;"> <thead> <tr> <th style="text-align: center;">A₁₇/S₄</th> <th style="text-align: center;">A₁₆-S₃</th> <th style="text-align: center;">Characteristics</th> </tr> </thead> <tbody> <tr> <td style="text-align: center;">0 (LOW)</td> <td style="text-align: center;">0</td> <td style="text-align: center;">Alternate Data</td> </tr> <tr> <td style="text-align: center;">0</td> <td style="text-align: center;">1</td> <td style="text-align: center;">Stack</td> </tr> <tr> <td style="text-align: center;">1 (HIGH)</td> <td style="text-align: center;">0</td> <td style="text-align: center;">Code or None</td> </tr> <tr> <td style="text-align: center;">1</td> <td style="text-align: center;">1</td> <td style="text-align: center;">Data</td> </tr> <tr> <td colspan="2" style="text-align: center;">S₆ is 0 (LOW)</td> <td></td> </tr> </tbody> </table> | A ₁₇ /S ₄ | A ₁₆ -S ₃ | Characteristics | 0 (LOW) | 0 | Alternate Data | 0 | 1 | Stack | 1 (HIGH) | 0 | Code or None | 1 | 1 | Data | S ₆ is 0 (LOW) | | |
| A ₁₇ /S ₄ | A ₁₆ -S ₃ | Characteristics | | | | | | | | | | | | | | | | | | | |
| 0 (LOW) | 0 | Alternate Data | | | | | | | | | | | | | | | | | | | |
| 0 | 1 | Stack | | | | | | | | | | | | | | | | | | | |
| 1 (HIGH) | 0 | Code or None | | | | | | | | | | | | | | | | | | | |
| 1 | 1 | Data | | | | | | | | | | | | | | | | | | | |
| S ₆ is 0 (LOW) | | | | | | | | | | | | | | | | | | | | | |
| 34 | BHE/S ₇ | O | Bus High Enable/Status. During T ₁ the bus high enable signal (BHE) should be used to enable data onto the most significant half of the data bus, pins D ₁₅ -D ₈ . Eight-bit oriented devices tied to the upper half of the bus would normally use BHE to condition chip select functions. BHE is LOW during T ₁ for read, write, and interrupt acknowledge cycles when a byte is to be transferred on the high portion of the bus. The S ₇ status information is available during T ₂ , T ₃ , and T ₄ . The signal is active LOW and floats to three-state OFF in "hold." It is LOW during T ₁ for the first interrupt acknowledge cycle. | | | | | | | | | | | | | | | | | | |
| | | | <table border="1" style="margin-left: auto; margin-right: auto;"> <thead> <tr> <th style="text-align: center;">BHE</th> <th style="text-align: center;">A₀</th> <th style="text-align: center;">Characteristics</th> </tr> </thead> <tbody> <tr> <td style="text-align: center;">0</td> <td style="text-align: center;">0</td> <td style="text-align: center;">Whole word</td> </tr> <tr> <td style="text-align: center;">0</td> <td style="text-align: center;">1</td> <td style="text-align: center;">Upper byte from/ to odd address</td> </tr> <tr> <td style="text-align: center;">1</td> <td style="text-align: center;">0</td> <td style="text-align: center;">Lower byte from/ to even address</td> </tr> <tr> <td style="text-align: center;">1</td> <td style="text-align: center;">1</td> <td style="text-align: center;">None</td> </tr> </tbody> </table> | BHE | A ₀ | Characteristics | 0 | 0 | Whole word | 0 | 1 | Upper byte from/ to odd address | 1 | 0 | Lower byte from/ to even address | 1 | 1 | None | | | |
| BHE | A ₀ | Characteristics | | | | | | | | | | | | | | | | | | | |
| 0 | 0 | Whole word | | | | | | | | | | | | | | | | | | | |
| 0 | 1 | Upper byte from/ to odd address | | | | | | | | | | | | | | | | | | | |
| 1 | 0 | Lower byte from/ to even address | | | | | | | | | | | | | | | | | | | |
| 1 | 1 | None | | | | | | | | | | | | | | | | | | | |
| 32 | RD | O | Read. Read strobe indicates that the processor is performing a memory of I/O read cycle, depending on the state of the S ₂ pin. This signal is used to read devices which reside on the 8086 local bus. RD is active LOW during T ₂ , T ₃ , and T _W of any read cycle and is guaranteed to remain HIGH in T ₂ until the 8086 local bus has floated. This signal floats to three-state OFF in "hold acknowledge." | | | | | | | | | | | | | | | | | | |
| 22 | READY | I | READY. Is the acknowledgment from the addressed memory or I/O device that it will complete the data transfer. The READY signal from memory/I/O is synchronized by the 8284A Clock Generator to form READY. This signal is active HIGH. The 8086 READY input is not synchronized. Correct operation is not guaranteed if the set-up and hold times are not met. | | | | | | | | | | | | | | | | | | |
| 18 | INTR | I | Interrupt Request. Is a level triggered input which is sampled during the last clock cycle of each instruction to determine if the processor should enter into an interrupt acknowledge operation. A subroutine is vectored to via an interrupt vector lookup table located in system memory. It can be internally masked by software resetting the interrupt enable bit. INTR is internally synchronized. This signal is active HIGH. | | | | | | | | | | | | | | | | | | |
| 23 | TEST | I | TEST. Input is examined by the "Wait" instruction. If the TEST input is LOW, execution continues; otherwise, the processor waits in an "idle" state. This input is synchronized internally during each clock cycle on the leading edge of CLK. | | | | | | | | | | | | | | | | | | |
| 17 | NMI | I | Non-Maskable Interrupt. An edge-triggered input which causes a type 2 interrupt. A subroutine is vectored to via an interrupt vector lookup table located in system memory. NMI is not maskable internally by software. A transition from a LOW to HIGH initiates the interrupt at the end of the current instruction. This input is internally synchronized. | | | | | | | | | | | | | | | | | | |
| 21 | RESET | I | Reset. Causes the processor to immediately terminate its present activity. The signal must be active HIGH for at least four clock cycles. It restarts execution, as described in the Instruction Set description, when RESET returns LOW. RESET is internally synchronized. | | | | | | | | | | | | | | | | | | |
| 19 | CLK | I | Clock. Provides the basic timing for the processor and bus controller. It is asymmetric with a 33% duty cycle to provide optimized internal timing. | | | | | | | | | | | | | | | | | | |
| 40 | V _{CC} | | V _{CC} . The +5 V power supply pin. | | | | | | | | | | | | | | | | | | |
| 1, 20 | GND | | Ground. The ground pin. | | | | | | | | | | | | | | | | | | |
| 33 | MN/MX | I | Minimum/Maximum. Indicates what mode the processor is to operate in. The two modes are discussed in the following sections. | | | | | | | | | | | | | | | | | | |

*Pin numbers correspond to DIPs only.

PIN DESCRIPTION (continued)

| Pin No.* | Name | I/O | Description | | | | | | | | | | | | | | | | | | | | | | | | | | | | | | | | | | | | |
|---------------------------------------|---|-------------|--|-------------|-------------|-------------|-----------------|---------|---|---|-----------------------|---|---|---|---------------|---|---|---|----------------|---|---|---|------|----------|---|---|-------------|---|---|---|-------------|---|---|---|--------------|---|---|---|---------|
| 28-26 | $\bar{S}_2, \bar{S}_1, \bar{S}_0$ | O | <p>Status. Active during $T_4, T_1,$ and T_2 and is returned to the passive state (1, 1, 1) during T_3 or during T_W when READY is HIGH. This status is used by the 8288 Bus Controller to generate all memory and I/O access control signals. Any change by $\bar{S}_2, \bar{S}_1,$ or \bar{S}_0 during T_4 is used to indicate the beginning of a bus cycle, and the return to the passive state in T_3 or T_W is used to indicate the end of a bus cycle. These signals float to three-state OFF in "hold acknowledge." These status lines are encoded as shown.</p> <table border="1" style="margin-left: auto; margin-right: auto; border-collapse: collapse;"> <thead> <tr> <th style="text-align: center;">\bar{S}_2</th> <th style="text-align: center;">\bar{S}_1</th> <th style="text-align: center;">\bar{S}_0</th> <th style="text-align: center;">Characteristics</th> </tr> </thead> <tbody> <tr> <td style="text-align: center;">0 (LOW)</td> <td style="text-align: center;">0</td> <td style="text-align: center;">0</td> <td>Interrupt Acknowledge</td> </tr> <tr> <td style="text-align: center;">0</td> <td style="text-align: center;">0</td> <td style="text-align: center;">1</td> <td>Read I/O Port</td> </tr> <tr> <td style="text-align: center;">0</td> <td style="text-align: center;">1</td> <td style="text-align: center;">0</td> <td>Write I/O Port</td> </tr> <tr> <td style="text-align: center;">0</td> <td style="text-align: center;">1</td> <td style="text-align: center;">1</td> <td>Halt</td> </tr> <tr> <td style="text-align: center;">1 (HIGH)</td> <td style="text-align: center;">0</td> <td style="text-align: center;">0</td> <td>Code Access</td> </tr> <tr> <td style="text-align: center;">1</td> <td style="text-align: center;">0</td> <td style="text-align: center;">1</td> <td>Read Memory</td> </tr> <tr> <td style="text-align: center;">1</td> <td style="text-align: center;">1</td> <td style="text-align: center;">0</td> <td>Write Memory</td> </tr> <tr> <td style="text-align: center;">1</td> <td style="text-align: center;">1</td> <td style="text-align: center;">1</td> <td>Passive</td> </tr> </tbody> </table> | \bar{S}_2 | \bar{S}_1 | \bar{S}_0 | Characteristics | 0 (LOW) | 0 | 0 | Interrupt Acknowledge | 0 | 0 | 1 | Read I/O Port | 0 | 1 | 0 | Write I/O Port | 0 | 1 | 1 | Halt | 1 (HIGH) | 0 | 0 | Code Access | 1 | 0 | 1 | Read Memory | 1 | 1 | 0 | Write Memory | 1 | 1 | 1 | Passive |
| \bar{S}_2 | \bar{S}_1 | \bar{S}_0 | Characteristics | | | | | | | | | | | | | | | | | | | | | | | | | | | | | | | | | | | | |
| 0 (LOW) | 0 | 0 | Interrupt Acknowledge | | | | | | | | | | | | | | | | | | | | | | | | | | | | | | | | | | | | |
| 0 | 0 | 1 | Read I/O Port | | | | | | | | | | | | | | | | | | | | | | | | | | | | | | | | | | | | |
| 0 | 1 | 0 | Write I/O Port | | | | | | | | | | | | | | | | | | | | | | | | | | | | | | | | | | | | |
| 0 | 1 | 1 | Halt | | | | | | | | | | | | | | | | | | | | | | | | | | | | | | | | | | | | |
| 1 (HIGH) | 0 | 0 | Code Access | | | | | | | | | | | | | | | | | | | | | | | | | | | | | | | | | | | | |
| 1 | 0 | 1 | Read Memory | | | | | | | | | | | | | | | | | | | | | | | | | | | | | | | | | | | | |
| 1 | 1 | 0 | Write Memory | | | | | | | | | | | | | | | | | | | | | | | | | | | | | | | | | | | | |
| 1 | 1 | 1 | Passive | | | | | | | | | | | | | | | | | | | | | | | | | | | | | | | | | | | | |
| 31, 30 | $\overline{RQ}/\overline{GT}_0,$ $\overline{RQ}/\overline{GT}_1$ | I/O | <p>Request/Grant. Pins are used by other local bus masters to force the processor to release the local bus at the end of the processor's current bus cycle. Each pin is bidirectional with $\overline{RQ}/\overline{GT}_0$ having higher priority than $\overline{RQ}/\overline{GT}_1.$ $\overline{RQ}/\overline{GT}$ has an internal pull-up resistor so it may be left unconnected. The request/grant sequence is as follows:</p> <ol style="list-style-type: none"> A pulse of 1 CLK wide from another local bus master indicates a local bus request ("hold") to the 8086 (pulse 1). During a T_4 or T_1 clock cycle, a pulse 1 CLK wide from the 8086 to the requesting master (pulse 2), indicates that the 8086 has allowed the local bus to float and that it will enter the "hold acknowledge" state at the next CLK. The CPU's bus interface unit is disconnected logically from the local bus during "hold acknowledge." A pulse 1 CLK wide from the requesting master indicates to the 8086 (pulse 3) that the "hold" request is about to end and that the 8086 can reclaim the local bus at the next CLK. <p>Each master-master exchange of the local bus is a sequence of 3 pulses. There must be one dead CLK cycle after each bus exchange. Pulses are active LOW.</p> <p>If the request is made while the CPU is performing a memory cycle, it will release the local bus during T_4 of the cycle when all the following conditions are met:</p> <ol style="list-style-type: none"> Request occurs on or before $T_2.$ Current cycle is not the low byte of a word (on an odd address). Current cycle is not the first acknowledge of an interrupt acknowledge sequence. A locked instruction is not currently executing. <p>If the local bus is idle when the request is made, two possible events will follow:</p> <ol style="list-style-type: none"> Local bus will be released during the next clock. A memory cycle will start within 3 clocks. Now the four rules for a currently active memory cycle apply with condition number 1 already satisfied. | | | | | | | | | | | | | | | | | | | | | | | | | | | | | | | | | | | | |
| 29 | LOCK | O | <p>LOCK. Output indicates that other system bus masters are not to gain control of the system bus while LOCK is active LOW. The LOCK signal is activated by the "LOCK" prefix instruction and remains active until the completion of the next instruction. This signal is active LOW, and floats to three-state OFF in "hold acknowledge."</p> | | | | | | | | | | | | | | | | | | | | | | | | | | | | | | | | | | | | |
| 24, 25 | QS_1, QS_0 | O | <p>Queue Status. The queue status is valid during the CLK cycle after which the queue operation is performed. QS_1 and QS_0 provide status to allow external tracking of the internal 8086 instruction queue.</p> | | | | | | | | | | | | | | | | | | | | | | | | | | | | | | | | | | | | |
| 28 | M/\overline{IO} | O | <p>Status line. Logically equivalent to S_2 in the maximum mode. It is used to distinguish a memory access from an I/O access. M/\overline{IO} becomes valid in the T_4 preceding a bus cycle and remains valid until the final T_4 of the cycle ($M = \text{HIGH}, \overline{IO} = \text{LOW}$). M/\overline{IO} floats to three-state OFF in local bus "hold acknowledge."</p> | | | | | | | | | | | | | | | | | | | | | | | | | | | | | | | | | | | | |
| 29 | WR | O | <p>Write. Indicates that the processor is performing a write memory or write I/O cycle, depending on the state of M/\overline{IO} signal. WR is active for $T_2, T_3,$ and T_W of any write cycle. It is active LOW and floats to three-state OFF in local bus "hold acknowledge."</p> | | | | | | | | | | | | | | | | | | | | | | | | | | | | | | | | | | | | |
| 24 | \overline{INTA} | O | <p>\overline{INTA}. Is used as a read strobe for interrupt acknowledge cycles. It is active LOW during $T_2, T_3,$ and T_W of each interrupt acknowledge cycle.</p> | | | | | | | | | | | | | | | | | | | | | | | | | | | | | | | | | | | | |
| 25 | ALE | O | <p>Address Latch Enable. Provided by the processor to latch the address into 8282/8283 address latch. It is a HIGH pulse active during T_1 of any bus cycle. Note that ALE is never floated.</p> | | | | | | | | | | | | | | | | | | | | | | | | | | | | | | | | | | | | |
| 27 | DT/\overline{R} | O | <p>Data Transmit/Receive. Needed in minimum system that desires to use an 8286/8287 data bus transceiver. It is used to control the direction of data flow through the transceiver. Logically DT/\overline{R} is equivalent to S_1 in the maximum mode, and its timing is the same as for M/\overline{IO}. ($T = \text{HIGH}, R = \text{LOW}$.) This signal floats to three-state OFF in local bus "hold acknowledge."</p> | | | | | | | | | | | | | | | | | | | | | | | | | | | | | | | | | | | | |
| 26 | DEN | O | <p>Data Enable. Provided as an output enable for the 8286/8287 in a minimum system which uses the transceiver. DEN is active LOW during each memory and I/O access and for \overline{INTA} cycles. For a read or \overline{INTA} cycle, it is active from the middle of T_2 until the middle of $T_4,$ while for a write cycle, it is active from the beginning of T_2 until the middle of $T_4.$ DEN floats to three-state OFF in local bus "hold acknowledge"</p> | | | | | | | | | | | | | | | | | | | | | | | | | | | | | | | | | | | | |
| *Pin numbers correspond to DIPs only. | | | | | | | | | | | | | | | | | | | | | | | | | | | | | | | | | | | | | | | |

| PIN DESCRIPTION (continued) | | | |
|-----------------------------|------------|-----|--|
| Pin No.* | Name | I/O | Description |
| 31, 30 | HOLD, HLDA | I/O | HOLD. Indicates that another master is requesting a local bus "hold." To be acknowledged, HOLD must be active HIGH. The processor receiving the "hold" request will issue HLDA (HIGH) as an acknowledgement in the middle of a T ₄ or T ₁ clock cycle. Simultaneous with the issuance of HLDA, the processor will float the local bus and control lines. After HOLD is detected as being LOW, the processor will LOWER HLDA, and when the processor needs to run another cycle, it will again drive the local bus and control lines. The same rules as for $\overline{RQ}/\overline{GT}$ apply, regarding when the local bus will be released. HOLD is not asynchronous input. External synchronization should be provided if the system cannot otherwise guarantee the set-up time. |

*Pin numbers correspond to DIPs only.

DETAILED DESCRIPTION

The 8086 CPU is internally organized into two processing units. These two units are the Bus Interface Unit (BIU) and the Execution Unit (EU). A block diagram of this organization is shown on page 1.

The BIU performs instruction fetch and queuing, operand fetch and store, address relocation, and basic bus control. The EU receives operands and instructions from the BIU and processes them on a 16-bit ALU. The EU accesses memory and peripheral devices through requests to the BIU. The BIU generates physical addresses in memory using the 4 segment registers and offset values.

The BIU and EU usually operate asynchronously. This permits the 8086 to overlap execution fetch and execution. Up to 6 instruction bytes can be queued. The instruction queue acts as a FIFO buffer for instructions, from which the EU extracts instruction bytes as required.

Memory Organization

The 8086 addresses up to 1 megabyte of memory. The address space is organized as a linear array, from 00000 to FFFFF in hexadecimal. Memory is subdivided into segments of 64K bytes each. There are 4 segments: code, stack, data, and extra (usually employed as an extra data segment). Each

segment thus contains information of a similar type. Selection of a destination segment is automatically performed using the rules in the table below. This segmentation makes memory more easily relocatable and supports a more structured programming style.

Physical addresses in memory are generated by selecting the appropriate segment, obtaining the segment "base" address from the segment register, shifting the base address 4 digits to the left, and then adding this base to the "offset" address. For programming code, the offset address is obtained from the instruction pointer. For operands, the offset address is calculated in several ways, depending upon information contained in the addressing mode. Memory organization and address generation are shown in Figure 1a.

Certain memory locations are reserved for specific CPU operations. These are shown in Figure 1b. Addresses FFFFOH through FFFFFH are reserved for operations which include a jump to the initial program loading routine. After RESET, the CPU will always begin execution at location FFFFOH, where the jump must be located.

Addresses 00000H through 003FFH are reserved for interrupt operations. The service routine of each of the 256 possible interrupt types is signaled by a 4-byte pointer. The pointer elements must be stored in reserved memory addresses before the interrupts are invoked.

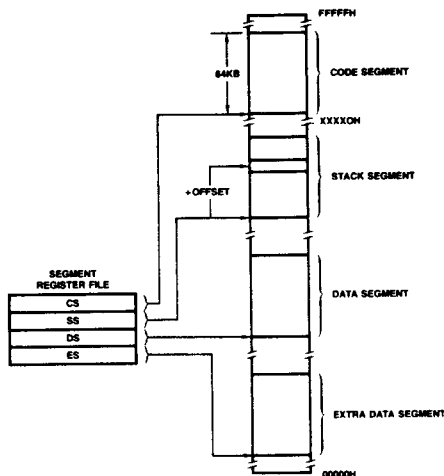

DF003310

Figure 1a. Memory Organization

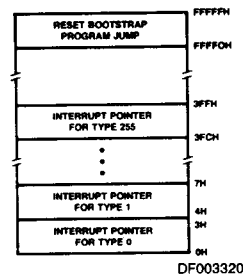

DF003320

Figure 1b. Reserved Memory Locations

| Memory Reference Need | Segment Register Used | Segment Selection Rule |
|------------------------|-----------------------|---|
| Instructions | CODE (CS) | Automatic for all prefetching of instructions. |
| Stack | STACK (SS) | All stack pushes and pops, and all memory references relative to BP base register except data references. |
| Local Data | DATA (DS) | Data references which are relative to the stack, the destination of a string operation, or explicitly overridden. |
| External (Global) Data | EXTRA (ES) | Destination of string operations, when they are explicitly selected using a segment override. |

Minimum and Maximum Modes

The 8086 has two system configurations, minimum and maximum mode. The CPU has a strap pin, MN/MX, which defines the system configuration. The status of this strap pin defines the function of pin numbers 24 through 31.

When MN/MX is strapped to GND, the 8086 operates in maximum mode. The operations of pins 24 through 31 are redefined. In maximum mode, several bus timing and control functions are "off-loaded" to the 8288 bus controller, thus

freeing up the CPU. The CPU communicates status information to the 8288 through pins S₀, S₁, and S₂. In maximum mode, the 8086 can operate in a multiprocessor system, using the LOCK signal within a Multibus format.

When MN/MX is strapped to V_{CC}, the 8086 operates in minimum mode. The CPU sends bus control signals itself through pins 24 through 31. This is shown in the Connection Diagrams (in parentheses). Examples of minimum and maximum mode systems are shown in Figure 2.

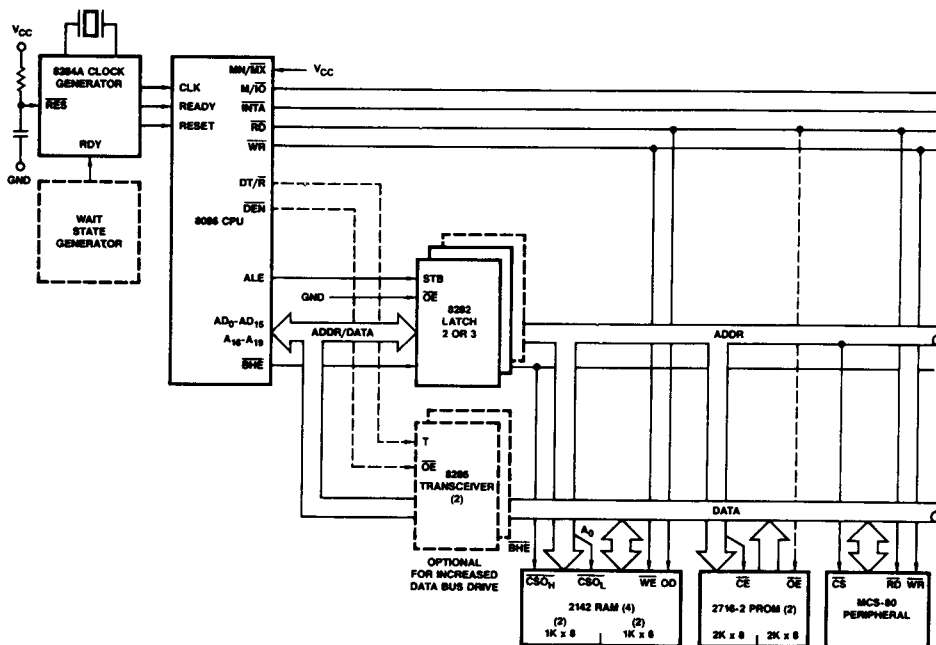

AF002850

Figure 2a. Minimum Mode 8086 Typical Configuration

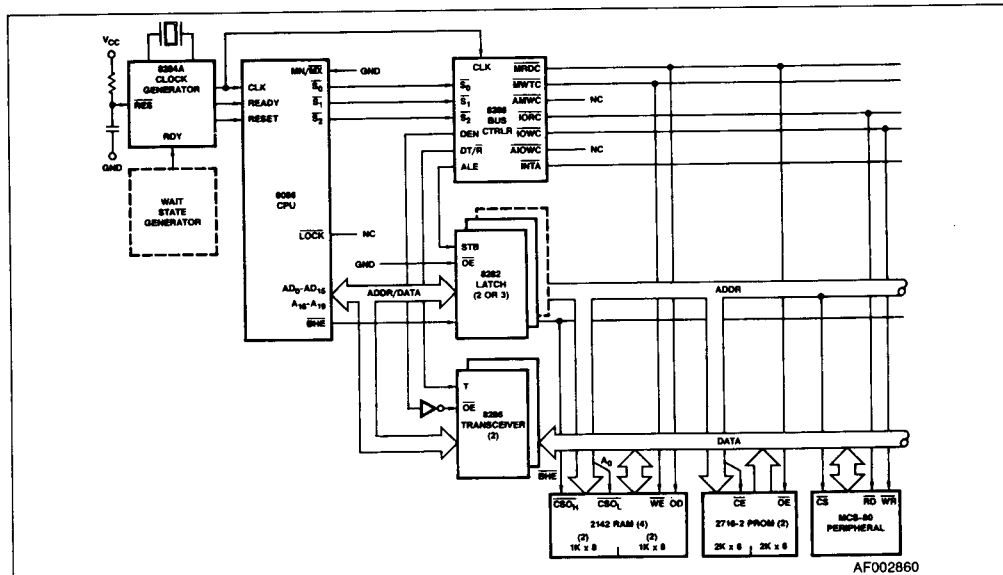

Figure 2b. Maximum Mode 8086 Typical Configuration

Bus Operation

The 8086 has a combined address and data bus, commonly referred to as "a time multiplexed bus." This technique provides the most efficient use of pins on the processor while permitting the use of a standard 40-lead package. This bus can be used throughout the system with address latching provided on memory and I/O modules. The bus can also be demultiplexed at the processor with a single set of address latches if a standard non-multiplexed bus is desired for the system.

Each bus cycle consists of at least four CLK cycles. These are referred to as T₁, T₂, T₃ and T₄ (see Figure 5). The address is sent from the processor during T₁. Data transfer occurs on the bus during T₃ and T₄. T₂ is used for changing the direction of the bus during read operations. In the event that a "NOT READY" indication is given by the addressed device, "Wait" states (T_W) are inserted between T₃ and T₄. Each inserted "Wait" state is of the same duration as a CLK cycle. "Idle" states (T_I) or inactive CLK cycles can occur between 8086 bus cycles. The processor uses these cycles for internal housekeeping.

During T₁ of any bus cycle, the ALE (Address Latch Enable) signal is emitted (by either the processor or the 8288 bus controller, depending on the MN/ \overline{MX} strap). At the trailing edge of this pulse, a valid address and certain status information for the cycle may be latched.

Status bits $\overline{S_0}$, $\overline{S_1}$, and $\overline{S_2}$ are used, in maximum mode, by the bus controller to identify the type of bus transaction according to the following table:

| $\overline{S_2}$ | $\overline{S_1}$ | $\overline{S_0}$ | Characteristics |
|------------------|------------------|------------------|------------------------|
| 0 (LOW) | 0 | 0 | Interrupt Acknowledge |
| 0 | 0 | 1 | Read I/O |
| 0 | 1 | 0 | Write I/O |
| 0 | 1 | 1 | Halt |
| 1 (HIGH) | 0 | 0 | Instruction Fetch |
| 1 | 0 | 1 | Read Data from Memory |
| 1 | 1 | 0 | Write Data to Memory |
| 1 | 1 | 1 | Passive (no bus cycle) |

Status bits S₃ through S₇ are multiplexed with high-order address bits and the BHE signal, and are therefore valid during T₂ through T₄. S₃ and S₄ indicate which segment register (see Instruction Set description) was used for this bus cycle in forming the address, according to the following table:

| S ₄ | S ₃ | Characteristics |
|----------------|----------------|--------------------------------|
| 0 (LOW) | 0 | Alternate Data (extra segment) |
| 0 | 1 | Stack |
| 1 (HIGH) | 0 | Code or None |
| 1 | 1 | Data |

S₅ is a reflection of the PSW interrupt enable bit. S₆ = 0 and S₇ is a spare status bit.

I/O Addressing

8086 I/O operations can address up to a maximum of 64K I/O byte registers or 32K I/O word registers. The I/O address appears in the same format as the memory address on bus lines A₁₅-A₀. The address lines A₁₉-A₁₆ are zero in I/O operations. I/O instructions which use register DX as a pointer have full address capability. Direct I/O instructions directly address one or two of the 256 I/O byte locations in page 0 of the I/O address space. I/O ports are addressed in the same manner as memory locations.

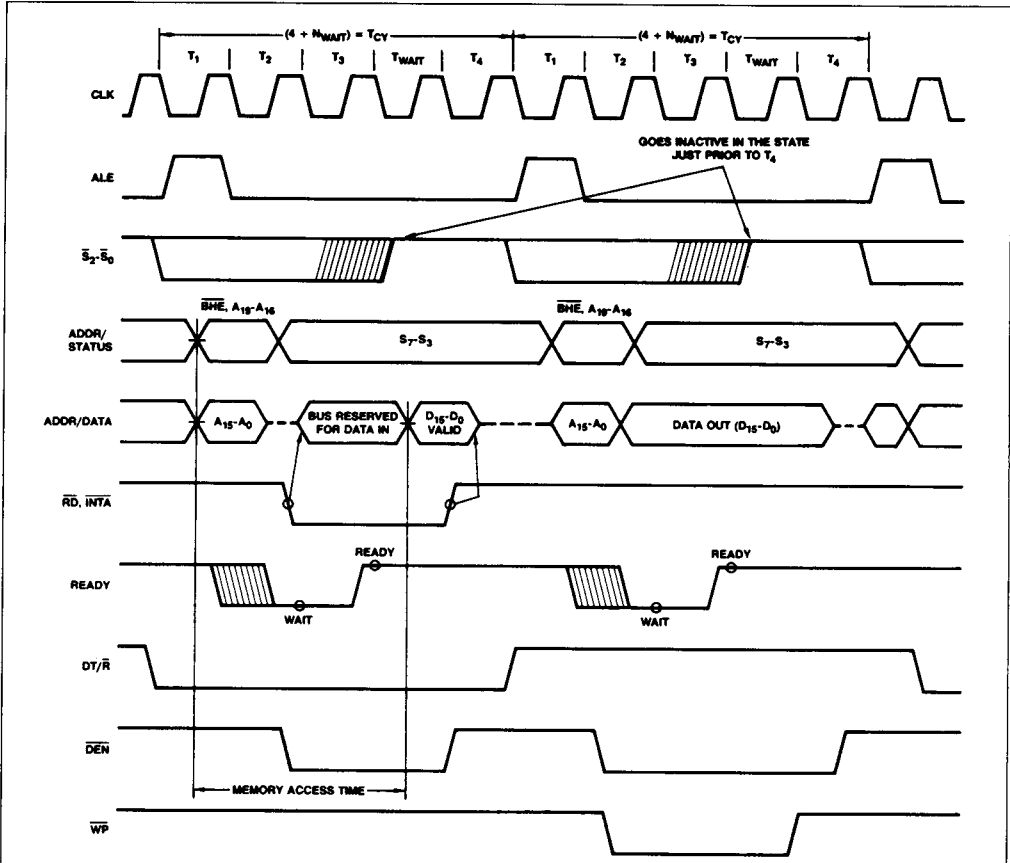

WF006650

Figure 3. Basic System Timing

EXTERNAL INTERFACE

Processor Reset and Initialization

Processor initialization or start up is accomplished with activation (HIGH) of the RESET pin. The 8086 RESET is required to be HIGH for greater than 4 CLK cycles. The 8086 will terminate operations on the high-going edge of RESET and will remain dormant as long as RESET is HIGH. The low-going transition of RESET triggers an internal reset sequence for approximately 10 CLK cycles. After this interval the 8086 operates normally beginning with the instruction in absolute location FFFF0H (see Figure 1b). The details of this operation are explained in the Instruction Set description of the MCS-86 Family User's Manual. The RESET input is internally synchronized to the processor clock. At initialization the HIGH-to-LOW transition of RESET must occur no sooner than 50 μ s after power-up, to allow complete initialization of the 8086.

NMI may not be asserted prior to the 2nd CLK cycle following the end of RESET.

Interrupt Operations

Interrupt operations fall into two classes: software or hardware initiated. The software initiated interrupts and software aspects of hardware interrupts are described in the Instruction Set description. Hardware interrupts are either non-maskable or maskable.

Interrupts transfer control to a new program location. A 256-element table containing address pointers to the interrupt service program locations resides in absolute locations 0 through 3FFH (see Figure 1b), which are reserved for this purpose. Each element in the table is 4 bytes in size and corresponds to an interrupt "type." An interrupting device supplies an 8-bit type number during the interrupt acknowledge sequence, which is used to "vector" through the appropriate element to the new interrupt service program location.

Non-Maskable Interrupt (NMI)

The processor provides a single non-maskable interrupt pin (NMI) which has higher priority than the maskable interrupt request pin (INTR). A typical use would be to activate a power



failure routine. The NMI is edge-triggered on a LOW-to-HIGH transition. The activation of this pin causes a type 2 interrupt. (See Instruction Set description.)

NMI is required to have a duration in the HIGH state of greater than two CLK cycles, but is not required to be synchronized to the clock. Any high-going transition of NMI is latched on-chip and will be serviced at the end of the current instruction or between whole moves of a block-type instruction. Worst case response to NMI would be to multiply, divide, and variable shift instructions. There is no specification on the occurrence of the low-going edge; it may occur before, during, or after the servicing of NMI. Another high-going edge triggers another response if it occurs after the start of the NMI procedure. The signal must be free of logical spikes in general and be free of bounces on the low-going edge to avoid triggering extraneous responses.

Maskable Interrupt (INTR)

The 86/10 provides a single interrupt request input (INTR) which can be masked internally by software with the resetting of the interrupt enable FLAG status bit. The interrupt request signal is level-triggered. It is internally synchronized during each clock cycle on the high-going edge of CLK. To be responded to, INTR must be present (HIGH) during the clock period preceding the end of the current instruction or the end of a whole move for a block-type instruction. During the interrupt response sequence, further interrupts are disabled. The enable bit is reset as part of the response to any interrupt (INTR, NMI, software interrupt, or single-step), although the FLAGS register, which is automatically pushed onto the stack, reflects the state of the processor prior to the interrupt. Until the old FLAGS register is restored, the enable bit will be zero unless specifically set by an instruction.

During the response sequence (Figure 4), the processor executes two successive (back-to-back) interrupt acknowledge cycles. The 8086 emits the LOCK signal from T_2 of the first bus cycle until T_2 of the second. A local bus "hold" request will not be honored until the end of the second bus cycle. In the second bus cycle, a byte is fetched from the external interrupt system (e.g., 8259A PIC) which identifies the source (type) of the interrupt. This byte is multiplied by four and used as a pointer into the interrupt vector lookup table. An INTR signal left HIGH will be continually responded to within the limitations of the enable bit and sample period. The INTERRUPT RETURN instruction includes a FLAGS pop, which returns the status of the original interrupt enable bit when it restores the FLAGS.

HALT

When a software "HALT" instruction is executed, the processor indicates that it is entering the "HALT" state in one of two ways depending upon which mode is strapped. In minimum mode, the processor issues one ALE with no qualifying bus control signals. In Maximum Mode, the processor issues appropriate HALT status on $\overline{S_2}, \overline{S_1}, \overline{S_0}$, and the 8288 bus controller issues one ALE. The 8086 will not leave the "HALT" state when a local bus "hold" is entered while in "HALT." In this case, the processor reissues the HALT indicator. An interrupt request or RESET will force the 8086 out of the "HALT" state.

Read/Modify/Write (Semaphore) Operation Via Lock

The LOCK status information is provided by the processor when directly consecutive bus cycles are required during the execution of an instruction. This provides the processor with the capability of performing read/modify/write operations on memory (via the Exchange Register With Memory instruction, for example) without the possibility of another system bus

master receiving intervening memory cycles. This is useful in multiprocessor system configurations to accomplish "test and set lock" operations. The LOCK signal is activated (forced LOW) in the clock cycle following the one in which the software "LOCK" prefix instruction is decoded by the EU. It is deactivated at the end of the last bus cycle of the instruction following the "LOCK" prefix instruction. While LOCK is active, a request on a RQ/GT pin will be recorded and then honored at the end of the LOCK.

External Synchronization Via Test

As an alternative to the interrupts and general I/O capabilities, the 8086 provides a single software-testable input known as the TEST signal. At any time, the program may execute a WAIT instruction. If at that time the TEST signal is inactive (HIGH), program execution becomes suspended while the processor waits for TEST to become active. It must remain active for at least 5 CLK cycles. The WAIT instruction is re-executed repeatedly until that time. This activity does not consume bus cycles. The processor remains in an idle state while waiting. All 8086 drivers go to three-state OFF if bus "HOLD" is entered. If interrupts are enabled, they may occur while the processor is waiting. When this occurs, the processor fetches the WAIT instruction one extra time, processes the interrupt, and then re-fetches and re-executes the WAIT instruction upon returning from the interrupt.

Basic System Timing

Typical system configurations for the processor operating in minimum mode and in maximum mode are shown in Figures 2a and 2b, respectively. In minimum mode, the processor emits bus control signals in a manner similar to the 8085. In maximum mode, the processor emits coded status information which the 8288 bus controller uses to generate MULTIBUS compatible bus control signals. Figure 3 illustrates the signal timing relationships.

System Timing - Minimum System

The read cycle begins in T_1 with the assertion of the Address Latch Enable (ALE) signal. The trailing (low-going) edge of this signal is used to latch the address information, which is valid on the local bus at this time, into the 8282/8283 latch. The \overline{BHE} and A_0 signals address the low, high, or both bytes. From T_1 to T_4 , the M/I/O signal indicates a memory or I/O operation. At T_2 the address is removed from the local bus and the bus goes to a high impedance state. The read control signal is also asserted at T_2 . The read (\overline{RD}) signal causes the addressed device to enable its data bus drivers to the local bus. Some time later valid data will be available on the bus and the addressed device will drive the READY line HIGH. When the processor returns the read signal to a HIGH level, the addressed device will again 3-state its bus drivers. If a transceiver (8286/8287) is required to buffer the 8086 local bus, signals DT/R and DEN are provided by the 8086.

A write cycle also begins with the assertion of ALE and the emission of the address. The M/I/O signal is again asserted to indicate a memory or I/O write operation. In the T_2 immediately following the address emission, the processor emits the data to be written into the addressed location. This data remains valid until the middle of T_4 . During T_2 , T_3 , and T_W , the processor asserts the write control signal. The write (\overline{WR}) signal becomes active at the beginning of T_2 as opposed to the read which is delayed somewhat into T_2 to provide time for the bus to float.

The \overline{BHE} and A_0 signals are used to select the proper byte(s) of the memory/I/O word to be read or written according to the following table.

| BHE | A ₀ | Characteristics |
|-----|----------------|---------------------------------|
| 0 | 0 | Whole word |
| 0 | 1 | Upper byte from/to odd address |
| 1 | 0 | Lower byte from/to even address |
| 1 | 1 | None |

I/O ports are addressed in the same manner as memory location. Even addressed bytes are transferred on the D₇-D₀ bus lines and odd addressed bytes on D₁₅-D₈.

The basic difference between the interrupt acknowledge cycle and a read cycle is that the interrupt acknowledge signal (INTA) is asserted in place of the read (RD) signal and the address bus is floated. (See Figure 6.) In the second of two successive INTA cycles, a byte of information is read from bus lines D₇-D₀ as supplied by the interrupt system logic (i.e., 8259A Priority Interrupt Controller). This byte identifies the source (type) of the interrupt. It is multiplied by four and used as a pointer into a interrupt vector lookup table, as described earlier.

Bus Timing — Medium Size Systems

For medium size systems, the MN/ \overline{MX} pin is connected to V_{SS}, and the 8288 Bus Controller is added to the system as well as

an 8282/8283 latch for latching the system address and a 8286/8287 transceiver to allow for bus loading greater than the 8086 is capable of handling. Signals ALE, DEN, and DT/ \overline{R} are generated by the 8288 instead of the processor in this configuration, although their timing remains relatively the same. The 8086 status (\overline{S}_2 , \overline{S}_1 , and \overline{S}_0) provide type-of-cycle information and become 8288 inputs. This bus cycle information specifies read (code, data, or I/O), write (data or I/O), interrupt acknowledge, or software halt. The 8288 thus issues control signals specifying memory read or write, I/O read or write, or interrupt acknowledge. The 8288 provides two types of write strobes, normal and advanced, to be applied as required. The normal write strobes have data valid at the leading edge of write. The advanced write strobes have the same timing as read strobes, and hence, data isn't valid at the leading edge of write. The 8286/8287 transceiver receives the usual T and OE inputs from the 8288's DT/ \overline{R} and DEN.

The pointer into the interrupt vector table, which is passed during the second INTA cycle, can derive from an 8259A located on either the local bus or the system bus. If the master 8259A Priority Interrupt Controller is positioned on the local bus, a TTL gate is required to disable the 8286/8287 transceiver when reading from the master 8259A during the interrupt acknowledge sequence and software "poll."

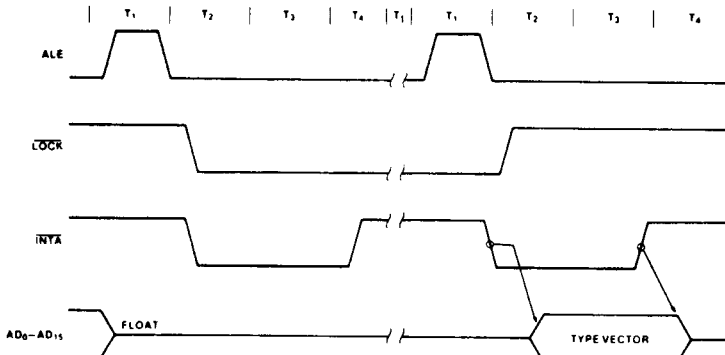

Figure 4. Interrupt Acknowledge Sequence

WF008371

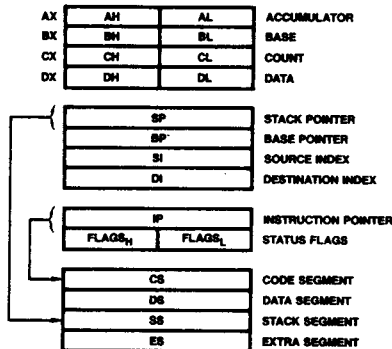

Figure 5. 8086 Register Model

DF003330

ABSOLUTE MAXIMUM RATINGS

Storage Temperature -65 to +150°C
 Ambient Temperature Under Bias 0 to 70°C
 Voltage on any Pin
 with Respect to Ground -1 to +7.0 V
 Power Dissipation 2.5 W

Stresses above those listed under ABSOLUTE MAXIMUM RATINGS may cause permanent device failure. Functionality at or above these limits is not implied. Exposure to absolute maximum ratings for extended periods may affect device reliability.

OPERATING RANGES

Commercial (C) Devices
 Temperature (T_A) 0 to +70°C
 Supply Voltage (V_{CC})
 8086 5 V ± 10%
 8086-1, 8086-2 5 V ± 5%

Industrial (I) Devices
 Temperature (T_A) -40 to +85°C
 Supply Voltage (V_{CC})
 8086 5 V ± 10%
 8086-1, 8086-2 5 V ± 5%

Operating ranges define those limits between which the functionality of the device is guaranteed.

DC CHARACTERISTICS over **COMMERCIAL** operating range

| Parameters | Description | Test Conditions | Min | Max | Units |
|-----------------|--|--|------|-----------------------|-------|
| V _{IL} | Input Low Voltage | | -0.5 | +0.8 | V |
| V _{IH} | Input High Voltage | | 2.0 | V _{CC} + 0.5 | V |
| V _{OL} | Output Low Voltage | I _{OL} = 2.5 mA | | 0.45 | V |
| V _{OH} | Output High Voltage | I _{OH} = -400 μA | 2.4 | | V |
| I _{CC} | Power Supply Current | All Speeds | | 340 | mA |
| I _{LI} | Input Leakage Current | 0V ≤ V _{IN} ≤ V _{CC} | | ±10 | μA |
| I _{LO} | Output Leakage Current | 0.45V ≤ V _{OUT} ≤ V _{CC} | | ±10 | μA |
| V _{CL} | Clock Input Low Voltage | | -0.5 | +0.6 | V |
| V _{CH} | Clock Input High Voltage | | 3.9 | V _{CC} + 1.0 | V |
| C _{IN} | Capacitance of Input Buffer (All input except AD ₀ -AD ₁₅ , RQ/GT) | f _c = 1 MHz | | 15 | pF |
| C _{IO} | Capacitance of I/O Buffer (AD ₀ -AD ₁₅ , RQ/GT) | f _c = 1 MHz | | 15 | pF |

SWITCHING CHARACTERISTICS over **COMMERCIAL** operating range
MINIMUM COMPLEXITY SYSTEM TIMING REQUIREMENTS

| Parameters | Description | Test Conditions | 8086 | | 8086-2 | | 8086-1 | | Units |
|------------|---|-------------------|------|-----|--------|-----|--------|-----|-------|
| | | | Min | Max | Min | Max | Min | Max | |
| TCLCL | CLK Cycle Period | | 200 | 500 | 125 | 500 | 100 | 500 | ns |
| TCLCH | CLK Low Time | | 118 | | 68 | | 53 | | ns |
| TCHCL | CLK High Time | | 69 | | 44 | | 39 | | ns |
| TCH1CH2 | CLK Rise Time | From 1.0 to 3.5V | | 10 | | 10 | | 10 | ns |
| TCL2CL1 | CLK Fall Time | From 3.5 to 1.0V | | 10 | | 10 | | 10 | ns |
| TDVCL | Data in Set-up Time | | 30 | | 20 | | 5 | | ns |
| TCLDX | Data in Hold Time | | 10 | | 10 | | 10 | | ns |
| TR1VCL | RDY Set-up Time into 8284A (See Notes 1, 2) | | 35 | | 35 | | 35 | | ns |
| TCLR1X | RDY Hold Time into 8284A (See Notes 1, 2) | | 0 | | 0 | | 0 | | ns |
| TRYHCH | READY Set-up Time into 8086 | | 118 | | 68 | | 53 | | ns |
| TCHRYX | READY Hold Time into 8086 | | 30 | | 20 | | 20 | | ns |
| TRYLCL | READY Inactive to CLK (See Note 3) | | -8 | | -8 | | -10 | | ns |
| THVCH | HOLD Set-up Time | | 35 | | 20 | | 20 | | ns |
| TINVCH | INTR, NMI, TEST Set-up Time (See Note 2) | | 30 | | 15 | | 15 | | ns |
| TILIH | Input Rise Time (Except CLK) | From 0.8 to 2.0 V | | 20 | | 20 | | 20 | ns |
| TIHIL | Input Fall Time (Except CLK) | From 2.0 to 0.8 V | | 12 | | 12 | | 12 | ns |

Notes: 1. Signal at 8284A shown for reference only.
 2. Set-up requirement for asynchronous signal only to guarantee recognition at next CLK.
 3. Applies only to T₂ state (8ns into T₃).

SWITCHING CHARACTERISTICS over **COMMERCIAL** operating range (continued)
TIMING RESPONSES

| Parameters | Description | Test Conditions | 8086 | | 8086-2 | | 8086-1 | | Units |
|------------|------------------------------------|--|-------------|------------|-------------|------------|-------------|-------|-------|
| | | | Min | Max | Min | Max | Min | Max | |
| TCLAV | Address Valid Delay | *C _L = 20-100 pF for all 8086 Outputs (in addition to 8086 self-load). Typical C _L = 100 pF. | 10 | 110 | 10 | 60 | 10 | 50 | ns |
| TCLAX | Address Hold Time | | 10 | | 10 | | 10 | | ns |
| TCLAZ | Address Float Delay | | TCLAX | 80 | TCLAX | 50 | 10 | 40 | ns |
| TLHLL | ALE Width | | TCLCH - 20 | | TCLCH - 10 | | TCLCH - 10 | | ns |
| TCLLH | ALE Active Delay | | | 80 | | 50 | | 40 | ns |
| TCHLL | ALE Inactive Delay | | | 85 | | 55 | | 45 | ns |
| TLLAX | Address Hold Time to ALE Inactive | | TCHCL - 10 | | TCHCL - 10 | | TCHCL - 10 | | ns |
| TCLDV | Data Valid Delay | | 10 | 110 | 10 | 60 | 10 | 50 | ns |
| TCHDX | Data Hold Time | | 10 | | 10 | | 10 | | ns |
| TWHDX | Data Hold Time After WR | | TCLCH - 30 | | TCLCH - 30 | | TCLCH - 25 | | ns |
| TCVCTV | Control Active Delay 1 | | 10 | 110 | 10 | 70 | 10 | 50 | ns |
| TCHCTV | Control Active Delay 2 | | 10 | 110 | 10 | 60 | 10 | 45 | ns |
| TCVCTX | Control Inactive Delay | | 10 | 110 | 10 | 70 | 10 | 50 | ns |
| TAZRL | Address Float to READ active | | 0 | | 0 | | 0 | | ns |
| TCLRL | RD Active Delay | | 10 | 165 | 10 | 100 | 10 | 70 | ns |
| TCLRH | RD Inactive Delay | | 10 | 150 | 10 | 80 | 10 | 60 | ns |
| TRHAV | RD Inactive to Next Address Active | | TCLCL - 45 | | TCLCL - 40 | | TCLCL - 35 | | ns |
| TCLHAV | HLDA Valid Delay | | 10 | 160 | 10 | 100 | 10 | 60 | ns |
| TRLRH | RD Width | | 2TCLCL - 75 | | 2TCLCL - 50 | | 2TCLCL - 40 | | ns |
| TWLWH | WR Width | | 2TCLCL - 60 | | 2TCLCL - 40 | | 2TCLCL - 35 | | ns |
| TAVAL | Address Valid to ALE Low | TCLCH - 60 | | TCLCH - 40 | | TCLCH - 35 | | ns | |
| TOLOH | Output Rise Time | From 0.8 to 2.0 V | | 20 | | 20 | | 20 ns | |
| TOHOL | Output Fall Time | From 2.0 to 0.8 V | | 12 | | 12 | | 12 ns | |

SWITCHING TEST INPUT/OUTPUT WAVEFORM

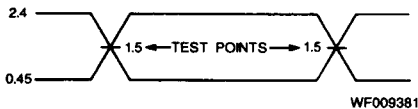

SWITCHING TEST LOAD CIRCUIT

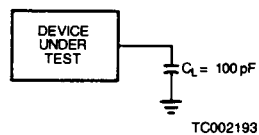

AC Testing inputs are driven at 2.4 V for a logic "1" and 0.45 V for a logic "0." Timing measurements are made at 1.5 V for both a logic "1" and "0."

C_L includes jig capacitance

SWITCHING CHARACTERISTICS over **COMMERCIAL** operating range (continued)
MAX MODE SYSTEM (USING 8288 BUS CONTROLLER)
TIMING REQUIREMENTS

| Parameters | Description | Test Conditions | 8086 | | 8086-2 | | 8086-1 | | Units |
|------------|---|-------------------|------|-----|--------|-----|--------|-----|-------|
| | | | Min | Max | Min | Max | Min | Max | |
| TCLCL | CLK Cycle Period | | 200 | 500 | 125 | 500 | 100 | 500 | ns |
| TCLCH | CLK Low Time | | 118 | | 68 | | 53 | | ns |
| TCHCL | CLK High Time | | 69 | | 44 | | 39 | | ns |
| TCH1CH2 | CLK Rise Time | From 1.0 to 3.5 V | | 10 | | 10 | | 10 | ns |
| TCL2CL1 | CLK Fall Time | From 3.5 to 1.0 V | | 10 | | 10 | | 10 | ns |
| TDVCL | Data in Set-up Time | | 30 | | 20 | | 5 | | ns |
| TCLDX | Data in Hold Time | | 10 | | 10 | | 10 | | ns |
| TR1VCL | RDY Set-up Time into 8284A (See Notes 1, 2) | | 35 | | 35 | | 35 | | ns |
| TCLR1X | RDY Hold Time into 8284A (See Notes 1, 2) | | 0 | | 0 | | 0 | | ns |
| TRYHCH | READY Set-up Time into 8086 | | 118 | | 68 | | 53 | | ns |
| TCHRYX | READY Hold Time into 8086 | | 30 | | 20 | | 20 | | ns |
| TRYLCL | READY Inactive to CLK (See Note 4) | | -8 | | -8 | | -10 | | ns |
| TINVCH | Set-up Time for Recognition (INTR, NMI, TEST (See Note 2) | | 30 | | 15 | | 15 | | ns |
| TGVCH | $\overline{RQ}/\overline{GT}$ Set-up Time | | 30 | | 15 | | 12 | | ns |
| TCHGX | \overline{RQ} Hold Time into 8086 | | 40 | | 30 | | 20 | | ns |
| TILIH | Input Rise Time (Except CLK) | From 0.8 to 2.0 V | | 20 | | 20 | | 20 | ns |
| TIHIL | Input Fall Time (Except CLK) | From 2.0 to 0.8 V | | 12 | | 12 | | 12 | ns |

- Notes: 1. Signal at 8284A or 8288 shown for reference only.
2. Set-up requirement for asynchronous signal only to guarantee recognition at next CLK.
3. Applies only to T3 and wait states.
4. Applies only to T2 state (8ns into T3).

SWITCHING CHARACTERISTICS over **COMMERCIAL** and **INDUSTRIAL** ranges (continued)
TIMING RESPONSES

| Parameters | Description | Test Conditions | 8086 | | 8086-2 | | 8086-1 | | Units |
|------------|---|--|------------|-------------|------------|-------------|------------|-----|-------|
| | | | Min | Max | Min | Max | Min | Max | |
| TCLML | Command Active Delay (See Note 1) | $C_L = 20\text{-}100\text{ pF}$ for all 8086 Outputs (In addition to 8086 self-load) | 10 | 35 | 10 | 35 | 10 | 35 | ns |
| TCLMH | Command Inactive Delay (See Note 1) | | 10 | 35 | 10 | 35 | 10 | 35 | ns |
| TRYHSH | READY Active to Status Passive (See Note 3) | | | 110 | | 65 | | 45 | ns |
| TCHSV | Status Active Delay | | 10 | 110 | 10 | 60 | 10 | 45 | ns |
| TCLSH | Status Inactive Delay | | 10 | 130 | 10 | 70 | 10 | 55 | ns |
| TCLAV | Address Valid Delay | | 10 | 110 | 10 | 60 | 10 | 50 | ns |
| TCLAX | Address Hold Time | | 10 | | 10 | | 10 | | ns |
| TCLAZ | Address Float Delay | | TCLAX | 80 | TCLAX | 50 | 10 | 40 | ns |
| TSVLH | Status Valid to ALE High (See Note 1) | | | 15 | | 15 | | 15 | ns |
| TSMVCH | Status Valid to MCE High (See Note 1) | | | 15 | | 15 | | 15 | ns |
| TCLLH | CLK Low to ALE Valid (See Note 1) | | | 15 | | 15 | | 15 | ns |
| TCLMCH | CLK Low to MCE High (See Note 1) | | | 15 | | 15 | | 15 | ns |
| TCHLL | ALE Inactive Delay (See Note 1) | | | 15 | | 15 | | 15 | ns |
| TCLMCL | MCE Inactive Delay (See Note 1) | | | 15 | | 15 | | 15 | ns |
| TCLDV | Data Valid Delay | | 10 | 110 | 10 | 60 | 10 | 50 | ns |
| TCHDX | Data Hold Time | | 10 | | 10 | | 10 | | ns |
| TCVNV | Control Active Delay (See Note 1) | | 5 | 45 | 5 | 45 | 5 | 45 | ns |
| TCVNX | Control Inactive Delay (See Note 1) | | 10 | 45 | 10 | 45 | 10 | 45 | ns |
| TAZRL | Address Float to Read Active | | 0 | | 0 | | 0 | | ns |
| TCLRL | \overline{RD} Active Delay | | 10 | 165 | 10 | 100 | 10 | 70 | ns |
| TCLRH | \overline{RD} Inactive Delay | | 10 | 150 | 10 | 80 | 10 | 60 | ns |
| TRHAV | \overline{RD} Inactive to Next Address Active | | TCLCL - 45 | | TCLCL - 40 | | TCLCL - 35 | | ns |
| TCHDTL | Direction Control Active Delay (See Note 1) | | | 50 | | 50 | | 50 | ns |
| TCHDTH | Direction Control Inactive Delay (See Note 1) | | | 30 | | 30 | | 30 | ns |
| TCLGL | GT Active Delay | | 0 | 85 | 0 | 50 | 0 | 38 | ns |
| TCLGH | GT Inactive Delay | 0 | 85 | 0 | 50 | 0 | 45 | ns | |
| TRLRH | \overline{RD} Width | 2TCLCL - 75 | | 2TCLCL - 50 | | 2TCLCL - 40 | | ns | |
| TOLOH | Output Rise Time | From 0.8 to 2.0 V | | 20 | | 20 | | ns | |
| TOHOL | Output Fall Time | From 2.0 to 0.8 V | | 12 | | 12 | | ns | |

- Notes: 1. Signal at 8284A or 8288 shown for reference only.
 2. Set-up requirement for asynchronous signal only to guarantee recognition at next CLK.
 3. Applies only to T3 and wait states.
 4. Applies only to T2 state (8ns into T3).

ABSOLUTE MAXIMUM RATINGS

Storage Temperature -65 to +150°C
 Ambient Temperature Under Bias 0 to 70°C
 Voltage on any Pin
 with Respect to Ground -1 to +7.0 V
 Power Dissipation 2.5 W

Stresses above those listed under ABSOLUTE MAXIMUM RATINGS may cause permanent device failure. Functionality at or above these limits is not implied. Exposure to absolute maximum ratings for extended periods may affect device reliability.

OPERATING RANGES

Military (M) Devices
 Temperature (T_C) -55 to +125°C
 Supply Voltage (V_{CC}) 5 V ±10%

Operating ranges define those limits between which the functionality of the device is guaranteed.

DC CHARACTERISTICS over **MILITARY** operating range (for APL Products, Group A, Subgroups 1, 2, 3 are tested unless otherwise noted)

| Parameter Symbol | Parameter Description | Test Conditions | Min. | Max. | Unit |
|---------------------|--|--|-------|------------------------|------|
| V _{IL} † | Input LOW Voltage | V _{CC} = Min. & Max. | -0.5* | +0.8 | V |
| V _{IH} † | Input HIGH Voltage | V _{CC} = Min. & Max. | 2.0 | V _{CC} + 0.5* | V |
| V _{OL} | Output LOW Voltage | I _{OL} = 2.0 mA, V _{CC} = Min. | | 0.45 | V |
| V _{OH} | Output HIGH Voltage | I _{OH} = -400 μA, V _{CC} = Min. | 2.4 | | V |
| I _{CC} | Power Supply Current (Note 1) | T _C = 25°C, V _{CC} = Max. | | 340 | mA |
| I _{LI} | Input Leakage Current | V _{CC} = Max., V _{IN} = 5.5 V & 0 V | -10 | 10 | μA |
| I _{LO} †† | Output Leakage Current | V _{CC} = Max., V _{OUT} = 5.5 V & 0.45 V | -10 | 10 | μA |
| V _{CL} † | Clock Input LOW Voltage | V _{CC} = Min. & Max. | -0.5* | +0.6 | V |
| V _{CH} † | Clock Input HIGH Voltage | V _{CC} = Min. & Max. | 3.9 | V _{CC} + 1.0* | V |
| C _{IN} ††† | Capacitance of Input Buffer (All Input Except AD ₀ -AD ₁₅ , RQ/GT) | f _c = 1 MHz | | 20* | pF |
| C _O ††† | Capacitance of I/O Buffer (AD ₀ -AD ₁₅ , RQ/GT) | f _c = 1 MHz | | 20* | pF |

* Guaranteed by design; not tested.
 † Group A, Subgroups 7 and 8 only are tested.
 †† Group A, Subgroups 1 and 2 only are tested.
 ††† Not included in Group A tests.

Notes: 1. I_{CC} is measured while running a functional pattern with spec value I_{OL}/I_{OH} loads applied.

SWITCHING CHARACTERISTICS over **MILITARY** operating range (for APL Products, Group A, Subgroups 9, 10, 11 are tested unless otherwise noted)

MINIMUM COMPLEXITY SYSTEM TIMING REQUIREMENTS

| Parameter Symbol | Parameter Description | Test Conditions (Note 6) | 8086 | | 8086-2 | | Unit |
|------------------|---|--------------------------|------|------|--------|------|------|
| | | | Min. | Max. | Min. | Max. | |
| TCLCL | CLK Cycle Period (Note 11) | | 200 | 500 | 125 | 500 | ns |
| TCLCH | CLK LOW Time | | 118 | | 68 | | ns |
| TCHCL | CLK HIGH Time | | 69 | | 44 | | ns |
| TCH1CH2 | CLK Rise Time (Note 5) | From 1.0 to 3.5 V | | 10 | | 10 | ns |
| TCL2CL1 | CLK Fall Time (Note 5) | From 3.5 to 1.0 V | | 10 | | 10 | ns |
| TDVCL | Data in Setup Time | | 30 | | 20 | | ns |
| TCLDX | Data in Hold Time | | 10 | | 10 | | ns |
| TR1VCL | RDY Setup Time into 8284A (Notes 1 & 2) | | 35 | | 35 | | ns |
| TCLR1X | RDY Hold Time into 8284A (Notes 1 & 2) | | 0 | | 0 | | ns |
| TRYHCH | READY Setup Time into 8086 | | 118 | | 68 | | ns |
| TCHRYX | READY Hold Time into 8086 | | 30 | | 20 | | ns |
| TRYLCL | READY Inactive to CLK (Note 4) | | -8 | | -8 | | ns |
| THVCH | HOLD Setup Time | | 35 | | 20 | | ns |
| TINVCH | INTR, NMI, TEST Setup Time (Note 2) | | 30 | | 15 | | ns |
| TILIH | Input Rise Time (Except CLK) (Note 5) | From 0.8 to 2.0 V | | 20 | | 20 | ns |
| TIHIL | Input Fall Time (Except CLK) (Note 5) | From 2.0 to 0.8 V | | 12 | | 12 | ns |

- Notes:
- Signal at 8284A and 8288 shown for reference only.
 - Setup requirement for asynchronous signal only to guarantee recognition at next CLK.
 - Applies only to T3 and wait states.
 - Applies only to T2 state (8 ns into T3).
 - Not tested; these specs are controlled by the Teradyne J941 tester.
 - VCC = 4.5 V, 5.5 V VIH = 2.4 V
VIL = .45 V VIHc = 4.3 V
VILc = .25 V VOH = 1.6 V
VOL = 1.4 V
 - Minimum spec tested at VCC Max. (5.5 V) only.
 - Maximum spec tested at VCC Min. (4.5 V) only.
 - Tested at VCC Max. (5.5 V) only.
 - Tested at VCC Min. (4.5 V) only.
 - Test conditions for TCLCL Max. are:
VCC = 4.5 V VOL = 1 V
VIL = 0 V VIH = 4 V
VILc = 0 V VIHc = 5 V

SWITCHING CHARACTERISTICS over MILITARY operating range (continued)

TIMING RESPONSES

| Parameter Symbol | Parameter Description | Test Conditions (Note 6) | 8086 | | 8086-2 | | Unit |
|------------------|--|--|------|------|--------|------|------|
| | | | Min. | Max. | Min. | Max. | |
| TCLAV | Address Valid Delay | CL = 100 pF for all 8086 Outputs (in addition to 8086 internal loads) | 10 | 110 | 10 | 60 | ns |
| TCLAX | Address Hold Time (Notes 7 & 8) | | 10 | | 10 | | ns |
| TCLAZ | Address Float Delay (Note 8) | | 10 | 80 | 10 | 50 | ns |
| TLHLL | ALE Width (Note 10) | | 98 | | 58 | | ns |
| TCLLH | ALE Active Delay (Note 8) | | | 80 | | 50 | ns |
| TCHLL | ALE Inactive Delay (Note 8) | | | 85 | | 55 | ns |
| TLLAX | Address Hold Time to ALE Inactive (Note 7) | | 59 | | 34 | | ns |
| TCLDV | Data Valid Delay (Note 8) | | 10 | 110 | 10 | 60 | ns |
| TCHDX | Data Hold Time (Note 10) | | 10 | | 10 | | ns |
| TWHDX | Data Hold Time After WR (Note 9) | | 88 | | 38 | | ns |
| TCVCTV | Control Active Delay 1 (Note 8) | | 10 | 110 | 10 | 70 | ns |
| TCHCTV | Control Active Delay 2 (Note 8) | | 10 | 110 | 10 | 60 | ns |
| TCVCTX | Control Inactive Delay (Note 8) | | 10 | 110 | 10 | 70 | ns |
| TAZRL | Address Float to READ Active (Note 9) | | 0 | | 0 | | ns |
| TCLRL | RD Active Delay (Note 8) | | 10 | 165 | 10 | 100 | ns |
| TCLRH | RD Inactive Delay (Note 8) | | 10 | 150 | 10 | 80 | ns |
| TRHAV | RD Inactive to Next Address Active (Note 10) | | 155 | | 85 | | ns |
| TCLHAV | HLDA Valid Delay (Note 8) | | 10 | 160 | 10 | 100 | ns |
| TRLRH | RD Width (Note 10) | | 325 | | 200 | | ns |
| TWLWH | WR Width (Note 10) | | 340 | | 210 | | ns |
| TAVAL | Address Valid to ALE LOW (Note 9) | 58 | | 28 | | ns | |
| TOLOH | Output Rise Time (Note 9) | From 0.8 to 2.0 V | | 20 | | 20 | ns |
| TOHOL | Output Fall Time (Note 9) | From 2.0 to 0.8 V | | 12 | | 12 | ns |

- Notes:
- Signal at 8284A and 8288 shown for reference only.
 - Setup requirement for asynchronous signal only to guarantee recognition at next CLK.
 - Applies only to T3 and wait states.
 - Applies only to T2 state (8 ns into T3).
 - Not tested; these specs are controlled by the Teradyne J941 tester.
 - VCC = 4.5 V, 5.5 V VIH = 2.4 V
VIL = 4.5 V VIH = 4.3 V
VILC = 2.5 V VOH = 1.6 V
VOL = 1.4 V
 - Minimum spec tested at VCC Max. (5.5 V) only.
 - Maximum spec tested at VCC Min. (4.5 V) only.
 - Tested at VCC Max. (5.5 V) only.
 - Tested at VCC Min. (4.5 V) only.
 - Test conditions for TCLCL Max. are:
VCC = 4.5 V VOL = 1 V
VIL = 0 V VIH = 4 V
VILC = 0 V VIH = 5 V

SWITCHING CHARACTERISTICS over MILITARY operating range (continued)

MAX MODE SYSTEM (USING 8288 BUS CONTROLLER) TIMING REQUIREMENTS

| Parameter Symbol | Parameter Description | Test Conditions (Note 6) | 8086 | | 8086-2 | | Unit |
|------------------|---|--------------------------|------|------|--------|------|------|
| | | | Min. | Max. | Min. | Max. | |
| TCLCL | CLK Cycle Period (Note 11) | | 200 | 500 | 125 | 500 | ns |
| TCLCH | CLK LOW Time | | 118 | | 68 | | ns |
| TCHCL | CLK HIGH Time | | 69 | | 44 | | ns |
| TCH1CH2 | CLK Rise Time (Note 5) | From 1.0 to 3.5 V | | 10 | | 10 | ns |
| TCL2CL1 | CLK Fall Time (Note 5) | From 3.5 to 1.0 V | | 10 | | 10 | ns |
| TDVCL | Data in Setup Time | | 30 | | 20 | | ns |
| TCLDX | Data in Hold Time | | 10 | | 10 | | ns |
| TR1VCL | RDY Setup Time into 8284A (Notes 1 & 2) | | 35 | | 35 | | ns |
| TCLR1X | RDY Hold Time into 8284A (Notes 1 & 2) | | 0 | | 0 | | ns |
| TRYHCH | READY Setup Time into 8086 | | 118 | | 68 | | ns |
| TCHRYX | READY Hold Time into 8086 | | 30 | | 20 | | ns |
| TRYLCL | READY Inactive to CLK (Note 4) | | -8 | | -8 | | ns |
| TINVCH | Setup Time for Recognition (INTR, NMI, TEST) (Note 2) | | 30 | | 15 | | ns |
| TGVCH | RQ/GT Setup Time | | 30 | | 15 | | ns |
| TCHGX | \overline{RQ} Hold Time into 8066 | | 40 | | 30 | | ns |
| TILIH | Input Rise Time (Except CLK) (Note 5) | From 0.8 to 2.0 V | | 20 | | 20 | ns |
| TIHIL | Input Fall Time (Except CLK) (Note 5) | From 2.0 to 0.8 V | | 12 | | 12 | ns |

- Notes:
- Signal at 8284A and 8288 shown for reference only.
 - Setup requirement for asynchronous signal only to guarantee recognition at next CLK.
 - Applies only to T3 and wait states.
 - Applies only to T2 state (8 ns into T3).
 - Not tested; these specs are controlled by the Teradyne J941 tester.
 - | | |
|--------------------------------|--------------------------|
| V _{CC} = 4.5 V, 5.5 V | V _{IH} = 2.4 V |
| V _{IL} = .45 V | V _{IHC} = 4.3 V |
| V _{ILC} = .25 V | V _{OH} = 1.6 V |
| V _{OL} = 1.4 V | |
 - Minimum spec tested at V_{CC} Max. (5.5 V) only.
 - Maximum spec tested at V_{CC} Min. (4.5 V) only.
 - Tested at V_{CC} Max. (5.5 V) only.
 - Tested at V_{CC} Min. (4.5 V) only.
 - Test conditions for TCLCL Max. are:

| | |
|-------------------------|------------------------|
| V _{CC} = 4.5 V | V _{OL} = 1 V |
| V _{IL} = 0 V | V _{IH} = 4 V |
| V _{ILC} = 0 V | V _{IHC} = 5 V |

SWITCHING CHARACTERISTICS over **MILITARY** operating range (continued)
TIMING RESPONSES

| Parameter Symbol | Parameter Description | Test Conditions (Note 6) | 8086 | | 8086-2 | | Unit |
|------------------|---|--|-------------------|------|--------|------|-------|
| | | | Min. | Max. | Min. | Max. | |
| TCLML | Command Active Delay (Note 1) | CL = 100 pF for all 8086 Outputs (In addition to 8086 internal loads) | 10 | 35 | 10 | 35 | ns |
| TCLMH | Command Inactive Delay (Note 1) | | 10 | 35 | 10 | 35 | ns |
| TRYHSH | READY Active to Status Passive (Note 3) | | | 110 | | 65 | ns |
| TCHSV | Status Active Delay (Notes 7 & 8) | | 10 | 110 | 10 | 60 | ns |
| TCLSH | Status Inactive Delay | | 10 | 130 | 10 | 70 | ns |
| TCLAV | Address Valid Delay | | 10 | 110 | 10 | 60 | ns |
| TCLAX | Address Hold Time | | 10 | | 10 | | ns |
| TCLAZ | Address Float Delay | | 10 | 80 | 10 | 50 | ns |
| TSVLH | Status Valid to ALE HIGH (Note 1) | | | 15 | | 15 | ns |
| TSVMCH | Status Valid to MCE HIGH (Note 1) | | | 15 | | 15 | ns |
| TCLLH | CLK LOW to ALE Valid (Note 1) | | | 15 | | 15 | ns |
| TCLMCH | CLK LOW to MCE HIGH (Note 1) | | | 15 | | 15 | ns |
| TCHLL | ALE Inactive Delay (Note 1) | | | 15 | | 15 | ns |
| TCLMCL | MCE Inactive Delay (Note 1) | | | 15 | | 15 | ns |
| TCLDV | Data Valid Delay | | 10 | 110 | 10 | 60 | ns |
| TCHDX | Data Hold Time | | 10 | | 10 | | ns |
| TCVNV | Control Active Delay (Note 1) | | 5 | 45 | 5 | 45 | ns |
| TCVNX | Control Inactive Delay (Note 1) | | 10 | 45 | 10 | 45 | ns |
| TAZRL | Address Float to Read Active | | 0 | | 0 | | ns |
| TCLRL | RD Active Delay | | 10 | 165 | 10 | 100 | ns |
| TCLRH | RD Inactive Delay | | 10 | 150 | 10 | 80 | ns |
| TRHAV | RD Inactive to Next Address Active | | 155 | | 85 | | ns |
| TCHDTL | Direction Control Active Delay (Note 1) | | | 50 | | 50 | ns |
| TCHDTH | Direction Control Inactive Delay (Note 1) | | | 30 | | 30 | ns |
| TCLGL | GT Active Delay (Note 8) | | 0 | 85 | 0 | 50 | ns |
| TCLGH | GT Inactive Delay (Note 8) | | 0 | 85 | 0 | 50 | ns |
| TRLRH | RD Width | | 325 | | 200 | | ns |
| TOLOH | Output Rise Time | | From 0.8 to 2.0 V | | 20 | | 20 ns |
| TOHOL | Output Fall Time | | From 2.0 to 0.8 V | | 12 | | 12 ns |

- Notes:
- Signal at 8284A and 8288 shown for reference only.
 - Setup requirement for asynchronous signal only to guarantee recognition at next CLK.
 - Applies only to T3 and wait states.
 - Applies only to T2 state (8 ns into T3).
 - Not tested; these specs are controlled by the Teradyne J941 tester.
 - VCC = 4.5 V, 5.5 V VIH = 2.4 V
VIL = .45 V VIHc = 4.3 V
VILc = .25 V VOH = 1.6 V
VOL = 1.4 V
 - Minimum spec tested at VCC Max. (5.5 V) only.
 - Maximum spec tested at VCC Min. (4.5 V) only.
 - Tested at VCC Max. (5.5 V) only.
 - Tested at VCC Min. (4.5 V) only.
 - Test conditions for TCLCL Max. are:
VCC = 4.5 V VOL = 1 V
VIL = 0 V VIH = 4 V
VILc = 0 V VIHc = 5 V

SWITCHING WAVEFORMS

MINIMUM MODE

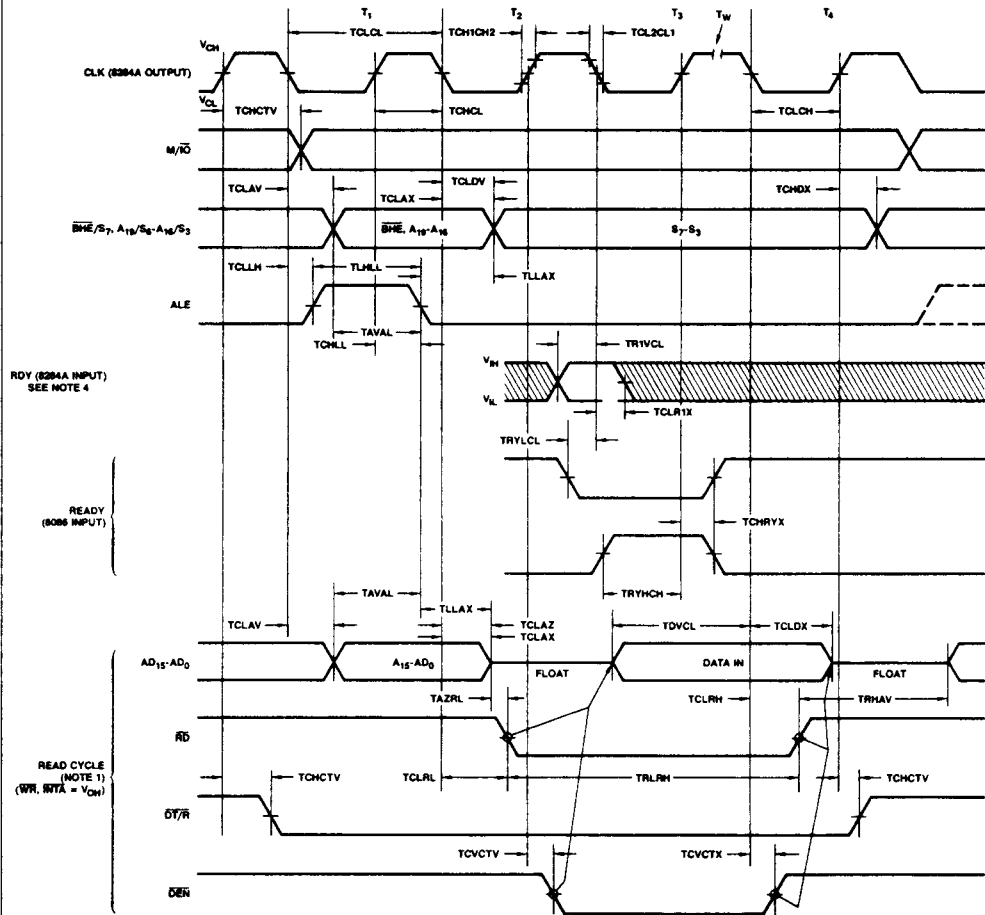

WF006660

SWITCHING WAVEFORMS (continued)

MAXIMUM MODE

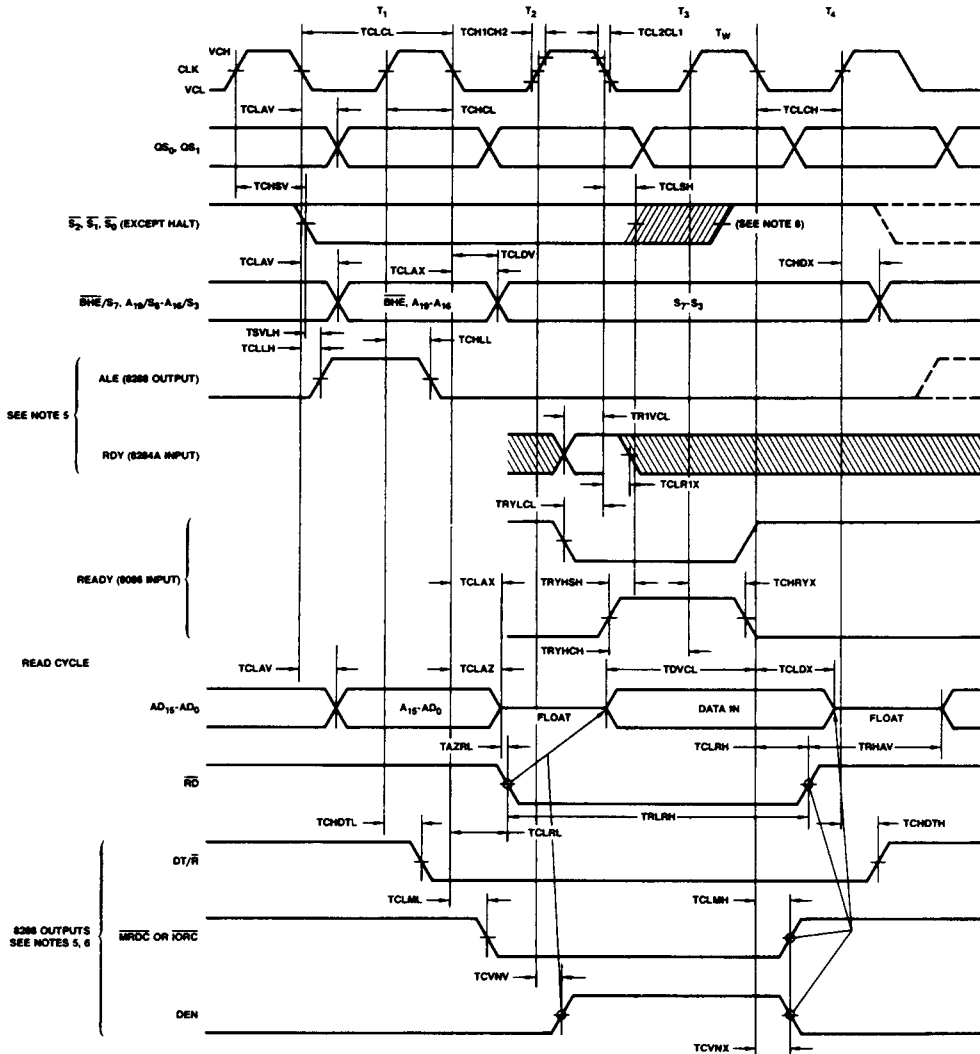

WF006680

SWITCHING WAVEFORMS (continued)

MAXIMUM MODE (continued)

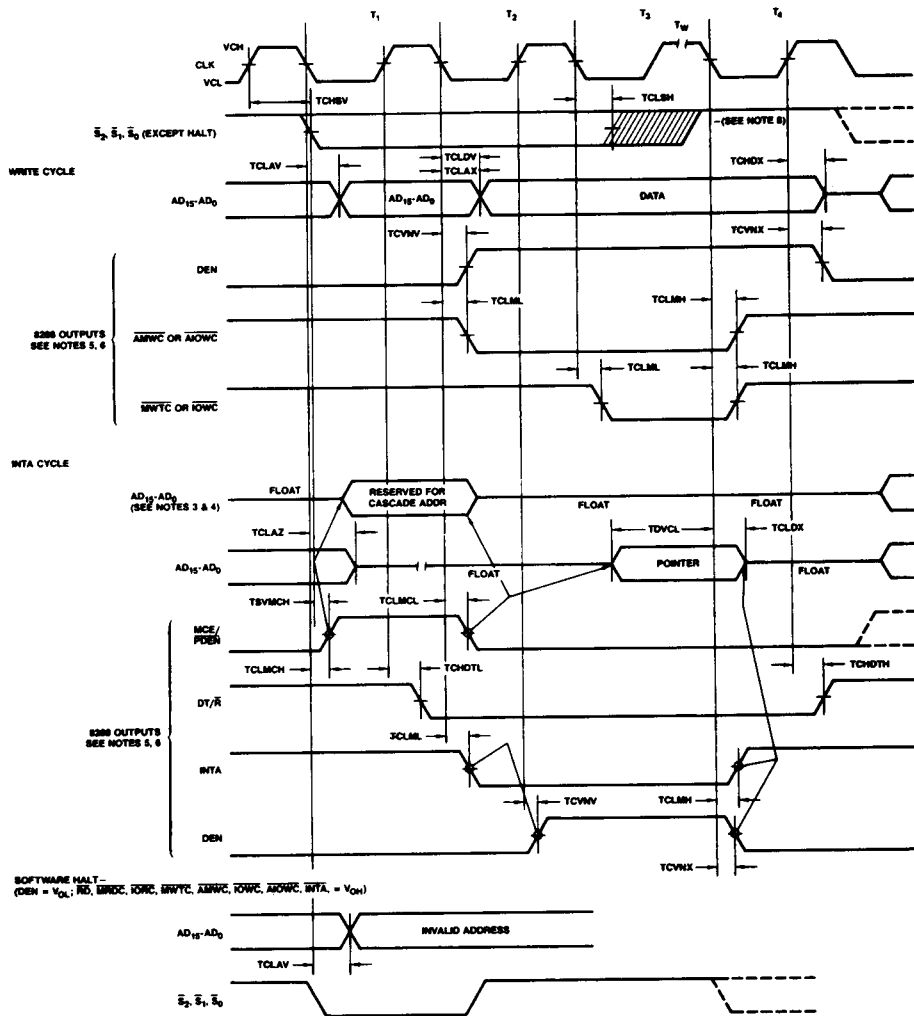

WF006730

- Notes:
1. All signals switch between V_{OH} and V_{OL} unless otherwise specified.
 2. RDY is sampled near the end of T_2, T_3, T_w to determine if T_w machines states are to be inserted.
 3. Cascade address is valid between first and second INTA cycle.
 4. Two INTA cycles run back-to-back. The 8086 LOCAL ADDR/DATA BUS is floating during both INTA cycles. Control for pointer address is shown for second INTA cycle.
 5. Signals at 8284A or 8288 are shown for reference only.
 6. The issuance of the 8288 command and control signals (\overline{MRDC} , \overline{MWTC} , \overline{AMWC} , \overline{IORC} , \overline{IOWC} , \overline{AOWC} , INTA and DEN) lags the active high 8288 CEN.
 7. All timing measurements are made at 1.5 V unless otherwise noted.
 8. Status inactive in state just prior to T_4 .

8086/8088 INSTRUCTION SET SUMMARY

DATA TRANSFER

MOV = Move

| | 7 6 5 4 3 2 1 0 | 7 6 5 4 3 2 1 0 | 7 6 5 4 3 2 1 0 | 7 6 5 4 3 2 1 0 |
|-------------------------------------|-----------------|-----------------|-----------------|-----------------|
| Register/memory to /from register | 1 0 0 0 1 0 d w | mod reg r/m | | |
| Immediate to register/memory | 1 1 0 0 0 1 1 w | mod 0 0 0 r/m | data | data if w = 1 |
| Immediate to register | 1 0 1 1 w reg | data | data if w = 1 | |
| Memory to accumulator | 1 0 1 0 0 0 0 w | addr-low | addr-high | |
| Accumulator to memory | 1 0 1 0 0 0 1 w | addr-low | addr-high | |
| Register/memory to segment register | 1 0 0 0 1 1 1 0 | mod 0 reg r/m | | |
| Segment register to register/memory | 1 0 0 0 1 1 0 0 | mod 0 reg r/m | | |

PUSH = Push:

| | | |
|------------------|-----------------|---------------|
| Register/memory | 1 1 1 1 1 1 1 1 | mod 1 1 0 r/m |
| Register | 0 1 0 1 0 reg | |
| Segment register | 0 0 0 reg 1 1 0 | |

POP = Pop:

| | | |
|------------------|-----------------|---------------|
| Register/memory | 1 0 0 0 1 1 1 1 | mod 0 0 0 r/m |
| Register | 0 1 0 1 1 reg | |
| Segment register | 0 0 0 reg 1 1 1 | |

XCHG = Exchange:

| | | |
|-------------------------------|-----------------|-------------|
| Register/memory with register | 1 0 0 0 0 1 1 w | mod reg r/m |
| Register with accumulator | 1 0 0 1 0 reg | |

IN = Input from:

| | | |
|---------------|-----------------|------|
| Fixed port | 1 1 1 0 0 1 0 w | port |
| Variable port | 1 1 1 0 1 1 0 w | |

OUT = Output to:

| | | |
|---------------|-----------------|------|
| Fixed port | 1 1 1 0 0 1 1 w | port |
| Variable port | 1 1 1 0 1 1 1 w | |

XLAT = Transtate byte to AL

| |
|-----------------|
| 1 1 0 1 0 1 1 1 |
|-----------------|

LEA = Load EA to register

| | |
|-----------------|-------------|
| 1 0 0 0 1 1 0 1 | mod reg r/m |
|-----------------|-------------|

LDS = Load pointer to DS

| | |
|-----------------|-------------|
| 1 1 0 0 0 1 0 1 | mod reg r/m |
|-----------------|-------------|

LES = Load pointer to ES

| | |
|-----------------|-------------|
| 1 1 0 0 0 1 0 0 | mod reg r/m |
|-----------------|-------------|

LANF = Load AH with flags

| |
|-----------------|
| 1 0 0 1 1 1 1 1 |
|-----------------|

SANF = Store AH into flags

| |
|-----------------|
| 1 0 0 1 1 1 1 0 |
|-----------------|

PUSHF = Push flags

| |
|-----------------|
| 1 0 0 1 1 1 0 0 |
|-----------------|

POPF = Pop flags

| |
|-----------------|
| 1 0 0 1 1 1 0 1 |
|-----------------|

INSTRUCTION SET SUMMARY (continued)

ARITHMETIC
ADD = Add

Register/memory with register to either

| | | | |
|-----------------|-----------------|-----------------|-----------------|
| 7 6 5 4 3 2 1 0 | 7 6 5 4 3 2 1 0 | 7 6 5 4 3 2 1 0 | 7 6 5 4 3 2 1 0 |
| 0 0 0 0 0 0 d w | mod reg r/m | | |

Immediate to register / memory

| | | | |
|-----------------|---------------|------|------------------|
| 1 0 0 0 0 0 s w | mod 0 0 0 r/m | data | data if s:w = 01 |
|-----------------|---------------|------|------------------|

Immediate to accumulator

| | | | |
|-----------------|------|---------------|--|
| 0 0 0 0 0 1 0 w | data | data if w = 1 | |
|-----------------|------|---------------|--|

ADC = Add with carry:

Register/memory with register to either

| | | | |
|-----------------|-------------|--|--|
| 0 0 0 1 0 0 d w | mod reg r/m | | |
|-----------------|-------------|--|--|

Immediate to register/memory

| | | | |
|-----------------|---------------|------|------------------|
| 1 0 0 0 0 0 s w | mod 0 1 0 r/m | data | data if s:w = 01 |
|-----------------|---------------|------|------------------|

Immediate to accumulator

| | | | |
|-----------------|------|---------------|--|
| 0 0 0 1 0 1 0 w | data | data if w = 1 | |
|-----------------|------|---------------|--|

INC = Increment:

Register/memory

| | | | |
|-----------------|---------------|--|--|
| 1 1 1 1 1 1 1 w | mod 0 0 0 r/m | | |
|-----------------|---------------|--|--|

Register

| | | | |
|---------------|--|--|--|
| 0 1 0 0 0 reg | | | |
|---------------|--|--|--|

AAA = ASCII adjust for add

| | | | |
|-----------------|--|--|--|
| 0 0 1 1 0 1 1 1 | | | |
|-----------------|--|--|--|

DAA = Decimal adjust for add

| | | | |
|-----------------|--|--|--|
| 0 0 1 0 0 1 1 1 | | | |
|-----------------|--|--|--|

SUB = Subtract:

Register/memory and register to either

| | | | |
|-----------------|-------------|--|--|
| 0 0 1 0 1 0 d w | mod reg r/m | | |
|-----------------|-------------|--|--|

Immediate from register/memory

| | | | |
|-----------------|---------------|------|------------------|
| 1 0 0 0 0 0 s w | mod 1 0 1 r/m | data | data if s:w = 01 |
|-----------------|---------------|------|------------------|

Immediate from accumulator

| | | | |
|-----------------|------|---------------|--|
| 0 0 1 0 1 1 0 w | data | data if w = 1 | |
|-----------------|------|---------------|--|

SBB = Subtract with borrow:

Register/memory and register to either

| | | | |
|-----------------|-------------|--|--|
| 0 0 0 1 1 0 d w | mod reg r/m | | |
|-----------------|-------------|--|--|

Immediate from register/memory

| | | | |
|-----------------|---------------|------|------------------|
| 1 0 0 0 0 0 s w | mod 0 1 1 r/m | data | data if s:w = 01 |
|-----------------|---------------|------|------------------|

Immediate from accumulator

| | | | |
|-----------------|------|---------------|--|
| 0 0 0 1 1 1 0 w | data | data if w = 1 | |
|-----------------|------|---------------|--|

DEC = Decrement:

Register/memory

| | | | |
|-----------------|---------------|--|--|
| 1 1 1 1 1 1 1 w | mod 0 0 1 r/m | | |
|-----------------|---------------|--|--|

Register

| | | | |
|---------------|--|--|--|
| 0 1 0 0 1 reg | | | |
|---------------|--|--|--|

NEG Change sign

| | | | |
|-----------------|---------------|--|--|
| 1 1 1 1 0 1 1 w | mod 0 1 1 r/m | | |
|-----------------|---------------|--|--|

CMP = Compare:

Register/memory with register

| | | | |
|-----------------|-------------|--|--|
| 0 0 1 1 1 0 1 w | mod reg r/m | | |
|-----------------|-------------|--|--|

Register with register/memory

| | | | |
|-----------------|-------------|--|--|
| 0 0 1 1 1 0 0 w | mod reg r/m | | |
|-----------------|-------------|--|--|

Immediate with register/memory

| | | | |
|-----------------|---------------|------|------------------|
| 1 0 0 0 0 0 s w | mod 1 1 1 r/m | data | data if s:w = 01 |
|-----------------|---------------|------|------------------|

Immediate with accumulator

| | | | |
|-----------------|------|---------------|--|
| 0 0 1 1 1 1 0 w | data | data if w = 1 | |
|-----------------|------|---------------|--|

AAS ASCII adjust for subtract

| | | | |
|-----------------|--|--|--|
| 0 0 1 1 1 1 1 1 | | | |
|-----------------|--|--|--|

DAS Decimal adjust for subtract

| | | | |
|-----------------|--|--|--|
| 0 0 1 0 1 1 1 1 | | | |
|-----------------|--|--|--|

MUL Multiply (unsigned)

| | | | |
|-----------------|---------------|--|--|
| 1 1 1 1 0 1 1 w | mod 1 0 0 r/m | | |
|-----------------|---------------|--|--|

IMUL Integer multiply (signed):

| | | | |
|-----------------|---------------|--|--|
| 1 1 1 1 0 1 1 w | mod 1 0 1 r/m | | |
|-----------------|---------------|--|--|

AAM ASCII adjust for multiply

| | | | |
|-----------------|-----------------|--|--|
| 1 1 0 1 0 1 0 0 | 0 0 0 0 1 0 1 0 | | |
|-----------------|-----------------|--|--|

DIV Divide (unsigned):

| | | | |
|-----------------|---------------|--|--|
| 1 1 1 1 0 1 1 w | mod 1 1 0 r/m | | |
|-----------------|---------------|--|--|

IDIV Integer divide (signed)

| | | | |
|-----------------|---------------|--|--|
| 1 1 1 1 0 1 1 w | mod 1 1 1 r/m | | |
|-----------------|---------------|--|--|

AAD ASCH adjust for divide

| | | | |
|-----------------|-----------------|--|--|
| 1 1 0 1 0 1 0 1 | 0 0 0 0 1 0 1 0 | | |
|-----------------|-----------------|--|--|

CBW Convert byte to word

| | | | |
|-----------------|--|--|--|
| 1 0 0 1 1 0 0 0 | | | |
|-----------------|--|--|--|

CWD Convert word to double word

| | | | |
|-----------------|--|--|--|
| 1 0 0 1 1 0 0 1 | | | |
|-----------------|--|--|--|



INSTRUCTION SET SUMMARY (continued)

LOGIC

| | 7 6 5 4 3 2 1 0 | 7 6 5 4 3 2 1 0 | 7 6 5 4 3 2 1 0 | 7 6 5 4 3 2 1 0 |
|--|-----------------|-----------------|-----------------|-----------------|
| NOT Invert | 1 1 1 1 0 1 1 w | mod 0 1 0 r/m | | |
| SHL/SAL Shift logical/arithmetic left | 1 1 0 1 0 0 v w | mod 1 0 0 r/m | | |
| SHR Shift logical right | 1 1 0 1 0 0 v w | mod 1 0 1 r/m | | |
| SAR Shift arithmetic right | 1 1 0 1 0 0 v w | mod 1 1 1 r/m | | |
| ROL Rotate left | 1 1 0 1 0 0 v w | mod 0 0 0 r/m | | |
| ROR Rotate right | 1 1 0 1 0 0 v w | mod 0 0 1 r/m | | |
| RCL Rotate through carry flag left | 1 1 0 1 0 0 v w | mod 0 1 0 r/m | | |
| RCR Rotate through carry right | 1 1 0 1 0 0 v w | mod 0 1 1 r/m | | |

AND = And:

| | | | | |
|-----------------------------------|-----------------|---------------|------|---------------|
| Reg/memory and register to either | 0 0 1 0 0 0 d w | mod reg r/m | | |
| Immediate to register/memory | 1 0 0 0 0 0 w | mod 1 0 0 r/m | data | data if w = 1 |
| Immediate to accumulator | 0 0 1 0 0 1 0 w | | data | data if w = 1 |

TEST = And function to flags, no result:

| | | | | |
|------------------------------------|-----------------|---------------|------|---------------|
| Register/memory and register | 1 0 0 0 1 0 w | mod reg r/m | | |
| Immediate data and register/memory | 1 1 1 1 0 1 1 w | mod 0 0 0 r/m | data | data if w = 1 |
| Immediate data and accumulator | 1 0 1 0 1 0 0 w | | data | data if w = 1 |

OR = Or:

| | | | | |
|-----------------------------------|-----------------|---------------|------|---------------|
| Reg/memory and register to either | 0 0 0 0 1 0 d w | mod reg r/m | | |
| Immediate to register/memory | 1 0 0 0 0 0 w | mod 0 0 1 r/m | data | data if w = 1 |
| Immediate to accumulator | 0 0 0 0 1 1 0 w | | data | data if w = 1 |

XOR = Exclusive or:

| | | | | |
|-----------------------------------|-----------------|---------------|------|---------------|
| Reg/memory and register to either | 0 0 1 1 0 0 d w | mod reg r/m | | |
| Immediate to register/memory | 1 0 0 0 0 0 w | mod 1 1 0 r/m | data | data if w = 1 |
| Immediate to accumulator | 0 0 1 1 0 1 0 w | | data | data if w = 1 |

STRING MANIPULATION:

| | |
|--------------------------------------|-----------------|
| REP = Repeat | 1 1 1 1 0 0 1 z |
| MOVS = Move byte/word | 1 0 1 0 0 1 0 w |
| CMPS = Compare byte/word | 1 0 1 0 0 1 1 w |
| SCAS = Scan byte/word | 1 0 1 0 1 1 1 w |
| LODS = Load byte/wd to AL/AX | 1 0 1 0 1 1 0 w |
| STOS = Stor byte/wd from AL/A | 1 0 1 0 1 0 1 w |

INSTRUCTION SET SUMMARY (continued)

CONTROL TRANSFER

CALL = Call

| | 7 6 5 4 3 2 1 0 | 7 6 5 4 3 2 1 0 | 7 6 5 4 3 2 1 0 | 7 6 5 4 3 2 1 0 |
|-------------------------|-----------------|-----------------|-----------------|-----------------|
| Direct within segment | 1 1 1 0 1 0 0 0 | disp-low | disp-high | |
| Indirect within segment | 1 1 1 1 1 1 1 1 | mod 0 1 0 r/m | | |
| Direct intersegment | 1 0 0 1 1 0 1 0 | offset-low | offset-high | |
| | | seg-low | seg-high | |
| Indirect intersegment | 1 1 1 1 1 1 1 1 | mod 0 1 1 r/m | | |

JMP = Unconditional jump:

| | | | | |
|-----------------------------|-----------------|---------------|-------------|--|
| Direct within segment | 1 1 1 0 1 0 0 1 | disp-low | disp-high | |
| Direct within segment-short | 1 1 1 0 1 0 1 1 | disp | | |
| Indirect within segment | 1 1 1 1 1 1 1 1 | mod 1 0 0 r/m | | |
| Direct intersegment | 1 1 1 0 1 0 1 0 | offset-low | offset-high | |
| | | seg-low | seg-high | |
| Indirect intersegment | 1 1 1 1 1 1 1 1 | mod 1 0 1 r/m | | |

RET = Return from CALL:

| | | | | |
|--|-----------------|----------|-----------|--|
| Within segment | 1 1 0 0 0 0 1 1 | | | |
| Within seg adding immed to SP | 1 1 0 0 0 0 1 0 | data-low | data-high | |
| Intersegment | 1 1 0 0 1 0 1 1 | | | |
| Intersegment adding immediate to SP | 1 1 0 0 1 0 1 0 | data-low | data-high | |
| JE/JZ = Jump on equal/zero | 0 1 1 1 0 1 0 0 | disp | | |
| JL/JNGE = Jump on less/not greater or equal | 0 1 1 1 1 1 0 0 | disp | | |
| JLE/JNG = Jump on less or equal/not greater | 0 1 1 1 1 1 1 0 | disp | | |
| JB/JNAE = Jump on below/not above or equal | 0 1 1 1 0 0 1 0 | disp | | |
| JBE/JNA = Jump on below or equal/not above | 0 1 1 1 0 1 1 0 | disp | | |
| JP/JPE = Jump on parity/parity even | 0 1 1 1 1 0 1 0 | disp | | |
| JO = Jump on overflow | 0 1 1 1 0 0 0 0 | disp | | |
| JS = Jump on sign | 0 1 1 1 1 0 0 0 | disp | | |
| JNE/JNZ = Jump on not equal/not zero | 0 1 1 1 0 1 0 1 | disp | | |
| JNL/JGE = Jump on not less/greater or equal | 0 1 1 1 1 1 0 1 | disp | | |
| JNLE/JG = Jump on not less or equal/greater | 0 1 1 1 1 1 1 1 | disp | | |
| JNB/JAE = Jump on not below/above or equal | 0 1 1 1 0 0 1 1 | disp | | |
| JNBE/JA = Jump on not below or equal/above | 0 1 1 1 0 1 1 1 | disp | | |
| JNP/JPO = Jump on not par/par odd | 0 1 1 1 1 0 1 1 | disp | | |
| JNO = Jump on not overflow | 0 1 1 1 0 0 0 1 | disp | | |
| JNS = Jump on not sign | 0 1 1 1 1 0 0 1 | disp | | |
| LOOP = Loop CX times | 1 1 1 0 0 0 1 0 | disp | | |
| LOCPZ/LOOPE = Loop while zero/equal | 1 1 1 0 0 0 0 1 | disp | | |
| LOOPNZ/LOOPNE = Loop while not zero/equal | 1 1 1 0 0 0 0 0 | disp | | |
| JCXZ = Jump on CX zero | 1 1 1 0 0 0 1 1 | disp | | |

INSTRUCTION SET SUMMARY (continued)

CONTROL TRANSFER (Cont'd.)

| | | | | |
|-------------------------------------|-----------------|-----------------|-----------------|-----------------|
| INT = Interrupt | 7 6 5 4 3 2 1 0 | 7 6 5 4 3 2 1 0 | 7 6 5 4 3 2 1 0 | 7 6 5 4 3 2 1 0 |
| Type specified | 1 1 0 0 1 1 0 1 | type | | |
| Type 3 | 1 1 0 0 1 1 0 0 | | | |
| INTO = Interrupt on overflow | 1 1 0 0 1 1 1 0 | | | |
| IRET = Interrupt return | 1 1 0 0 1 1 1 1 | | | |

PROCESSOR CONTROL

| | | |
|---|-----------------|---------------|
| CLC = Clear carry | 1 1 1 1 1 0 0 0 | |
| CMC = Complement carry | 1 1 1 1 0 1 0 1 | |
| STC = Set carry | 1 1 1 1 1 0 0 1 | |
| CLD = Clear direction | 1 1 1 1 1 1 0 0 | |
| STD = Set direction | 1 1 1 1 1 1 0 1 | |
| CLI = Clear interrupt | 1 1 1 1 1 0 1 0 | |
| STI = Set interrupt | 1 1 1 1 1 0 1 1 | |
| HLT = Halt | 1 1 1 1 0 1 0 0 | |
| WAIT = Wait | 1 0 0 1 1 0 1 1 | |
| ESC = Processor Extension Escape | 1 1 0 1 1 x x x | mod x x x r/m |
| LOCK = Bus lock prefix | 1 1 1 1 0 0 0 0 | |

Footnotes:

AL = 8-bit accumulator
 AX = 16-bit accumulator
 CX = Count register
 DS = Data segment
 ES = Extra segment
 Above/below refers to unsigned value.
 Greater = more positive.
 Less = less positive (more negative) signed values
 if d = 1 then "to" reg; if d = 0 then "from" reg
 w = 1 then word instruction; if w = 0 then byte instruction

if mod = 11 then r/m is treated as a REG field
 if mod = 00 then DISP = 0, disp-low and disp-high are absent
 if mod = 01 then DISP = disp-low sign-extended to 16-bits, disp-high is absent
 if mod = 10 then DISP = disp-high: disp-low

if r/m = 000 then EA = (BX) + (SI) + DISP
 if r/m = 001 then EA = (BX) + (DI) + DISP
 if r/m = 010 then EA = (BP) + (SI) + DISP
 if r/m = 011 then EA = (BP) + (DI) + DISP
 if r/m = 100 then EA = (SI) + DISP
 if r/m = 101 then EA = (DI) + DISP
 if r/m = 110 then EA = (BP) + DISP*
 if r/m = 111 then EA = (BX) + DISP

DISP follows 2nd byte of instruction (before data if required)

*except if mod = 00 and r/m = 110 then EA = disp-high: disp-low.

if s:w = 01 then 16 bits of immediate data form the operand.
 if s:w = 11 then an immediate data byte is sign extended to form the 16-bit operand.
 if v = 0 then "count" = 1; if v = 1 then "count" in (CL)
 x = don't care
 z is used for string primitives for comparison with ZF Flag.

SEGMENT OVERRIDE PREFIX

| | | | | | | |
|---|---|---|-----|---|---|---|
| 0 | 0 | 1 | reg | 1 | 1 | 0 |
|---|---|---|-----|---|---|---|

REG is assigned according to the following table:

| 16-Bit (w = 1) | 8-Bit (w = 0) | Segment |
|----------------|---------------|---------|
| 000 AX | 000 AL | 00 ES |
| 001 CX | 001 CL | 01 CS |
| 010 DX | 010 DL | 10 SS |
| 011 BX | 011 BL | 11 DS |
| 100 SP | 100 AH | |
| 101 BP | 101 CH | |
| 110 SI | 110 DH | |
| 111 DI | 111 BH | |

Instructions which reference the flag register files as a 16-bit object use the symbol FLAGS to represent the file:
 FLAGS = X:X:X:(OF):(DF):(TF):(SF):(ZF):X:(AF):X:(PF):X:(CF)

This datasheet has been downloaded from:

www.DatasheetCatalog.com

Datasheets for electronic components.



LittleDiode supplies new, hard to find or obsolete electronic components and semiconductors all over the world.

With over two million different components listed you are sure to find the part you need.

Feel free to visit us today at our online store:

LittleDiode.com

Looking forward to providing you with the best possible service.