

ISC300

Universal Precision Isolated MEASUREMENT CHANNEL

FEATURES

- CALIBRATION CAPABILITY
- INTEGRAL SENSOR EXCITATION
- OPEN CIRCUIT SENSOR DETECTION
- LOW POWER: 80mW
- INSTRUMENT AMPLIFIER INPUT
- PROGRAMMABLE GAIN
- 12-BIT LINEARITY
- TWO ISOLATED POWER SUPPLIES: $\pm 13V$ at 5mA
- LOW DRIFT 10V REFERENCE

APPLICATIONS

- UNIVERSAL INPUT CHANNEL FOR PROCESS CONTROL SYSTEMS
- ISOLATED MEASUREMENT CHANNEL FOR THERMOCOUPLE, RTD AND VOLTAGE TRANSDUCERS
- CHANNEL TO CHANNEL ISOLATED MULTIPLEXED SYSTEMS
- ISOLATED 4 TO 20mA RECEIVER

DESCRIPTION

The ISC300 is an isolated measurement channel with open circuit sensor detection for use with RTD and thermocouple temperature sensors. In addition to temperature measurement, the ISC300 can accept full scale input voltages of $\pm 100mV$ and $\pm 10V$ which allows use with other sensors such as pressure, humidity and flow sensors. The low level resistance measurement capability also allows stimulus and measure-

ment of strain gauges. The measurement channel has a highly stable internal reference which can be selected from the output side. This allows the user to calibrate each channel at the factory, record the calibration data and periodically recalibrate the system while in use over time and ambient temperature changes.

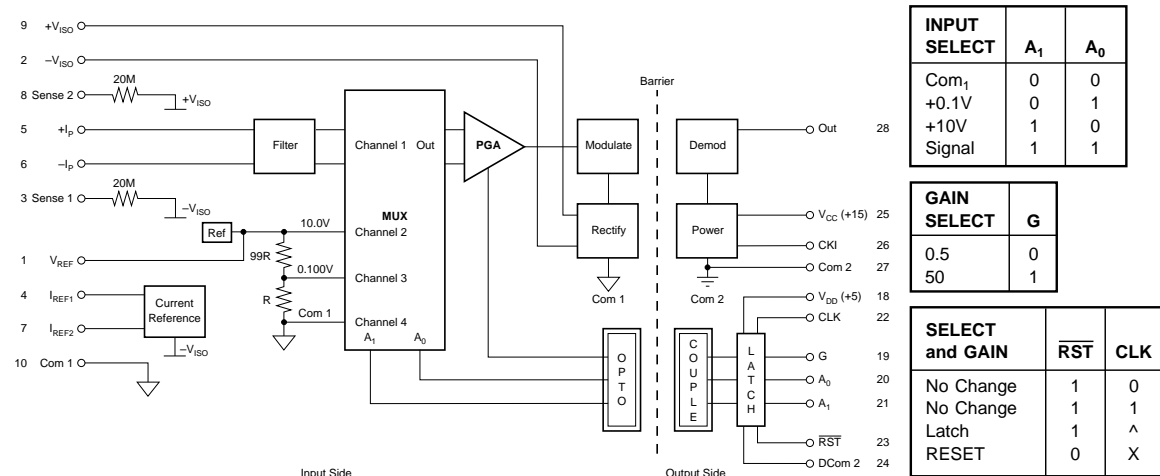

International Airport Industrial Park • Mailing Address: PO Box 11400 • Tucson, AZ 85734 • Street Address: 6730 S. Tucson Blvd. • Tucson, AZ 85706
 Tel: (520) 746-1111 • Twx: 910-952-1111 • Cable: BBRCORP • Telex: 066-6491 • FAX: (520) 889-1510 • Immediate Product Info: (800) 548-6132

SPECIFICATIONS

ELECTRICAL

At $V_{CC} = 15V$, $V_{DD} = 5V$, $T_A = +25^{\circ}C$, unless otherwise noted.

PARAMETER	CONDITIONS	ISC300			UNITS
		MIN	TYP	MAX	
ISOLATION Isolation Voltage (V_{ISO}) Isolation Mode Rejection (IMR) Barrier Impedance Leakage Current (I_{ISO})	AC60Hz Continuous AC60Hz Continuous V_{ISO} , DC Partial Discharge ⁽¹⁾ $V_{ISO} = \text{Rated } 60\text{Hz Cont}^{(2)}$ $V_{ISO} = 240 \text{ Vrms } 60\text{Hz}$	500 ± 700 700 800 110			V_{rms} V_{PEAK} V V_{rms} dB $G\Omega \parallel pF$ μArms
GAIN Voltage Gains Resistance Conversion Initial Error vs Temperature Nonlinearity	$0^{\circ}C \text{ to } +70^{\circ}C$ $V_O = -5V \text{ to } +5V^{(4)}$		50, 0.5 10		V/V mV/ Ω % ppm/ $^{\circ}C$ %
INPUT OFFSET VOLTAGE Initial Offset (Input Referred) vs Temperature vs Supply (V_{CC})	$V_{IN} = 0V \text{ } G = 0.5$ $V_{IN} = 0V \text{ } G = 50$ $0^{\circ}C \text{ to } +70^{\circ}C \text{ } G = 0.5$ $0^{\circ}C \text{ to } +70^{\circ}C \text{ } G = 50$ $V_{CC} = 14V \text{ to } 16V$			± 200 ± 5 ± 200 ± 5	mV mV $\mu V/^{\circ}C$ $\mu V/^{\circ}C$ mV/V
INPUT CURRENT Initial Bias vs Temperature	$-40^{\circ}C \text{ to } +85^{\circ}C$		35 100	50	nA pA/ $^{\circ}C$
INPUT Voltage Range Resistance Range Peak Voltage Impedance: Differential Common Mode Rejection Source Impedance Imbalance	Rated Operation $G = 0.5V \text{ Input}$ Rated Operation $G = 50V \text{ Input}$ Rated Operation $G = 50 \text{ 3-wire Resistance}$ Applied to Any Signal Input Wrt Com 1 ⁽⁵⁾ CMR at DC Gain = 0.5 ⁽³⁾ CMR at DC Gain = 50 ⁽³⁾ CMR at 60Hz ⁽³⁾ For Normal Operation < 1k Ω Imbalance	0 10 66 75 60	75 100 70	± 10 ± 0.1 500 ± 380	V V Ω V M Ω dB dB dB k Ω
OUTPUT Voltage Range Overrange Voltage Output Impedance Ripple Voltage	Min Load = 1M Ω During Input Fault ($V_{IN} < -11V \text{ or } V_{IN} > 11V$) $f = 0 \text{ to } 5\text{kHz Min Load } 1M\Omega$ $f = 0 \text{ to } 100\text{kHz Min Load } 1M\Omega$	± 5.4	3 0.5 10	± 5	V V k Ω mVrms mVp-p
FREQUENCY RESPONSE Input Bandwidth Input Settling Time Input Overload Recovery Output Overload Settling Time Output Overload Recovery	T_{SETT} , to within 5% for $V_{IN} < 14V$		3.5 0.5 5 1 2	5	Hz s s ms ms
VOLTAGE REFERENCE V_{REF1} (Internal and External) Initial Accuracy vs Temperature vs Time vs Supply (V_{CC}) V_{REF2} (Internal) Initial Accuracy ⁽⁶⁾ vs Temperature vs Time vs Supply (V_{CC})	External Loading of 100nA		10 ± 0.1 ± 10	± 1 ± 20 ± 20	V % ppm/ $^{\circ}C$ ppm/kHr %/V mV % ppm/ $^{\circ}C$ ppm/kHr %/V
POWER SUPPLIES Analog Supply Range Supply Current Digital Supply Range Supply Current Total Power Dissipation Isolated Supplies: Voltage Current	V_{CC} Pin No External Load V_{DD} Pin No External Load at 5mA Each Supply	14 4 11.5	5 1 80 13 5	16 10 6 3 184	V mA V mA mW V mA

SPECIFICATIONS (CONT)

ELECTRICAL

At $V_{CC} = 15V$, $V_{DD} = 5V$, $T_A = +25^{\circ}C$, unless otherwise noted.

PARAMETER	CONDITIONS	ISC300			UNITS
		MIN	TYP	MAX	
INPUT O/C SENSE Sense Current	I_{S2} , Sense 1 = 0V $-I_{S2}$, Sense 2 = 0V		0.7 0.7		μA μA
REFERENCE CURRENT Reference Current (I_{REF1}) Reference Currents Ratio	$I_{REF1} : I_{REF2}$	199	200	201 ± 0.5	μA %
DIGITAL INPUTS A_0, A_1, G, CLK, RST (74HC EQUIVALENT) High-Level Input Voltage Low-Level Input Voltage Input Rise and Fall Times (t_R , t_F) Pulse Width (t_W) Setup (t_{SU}) Hold (t_{HO}) Release (t_{REG})	CLK \overline{RST} A_0 , A_1 , G CLK, \overline{RST} Data Change to CLK High Data Change from CLK High RST High to CLK High	3.5 20 20 5 5	 	1.5 450	V V ns ns ns ns ns
CLOCK SYNC CKI Input Voltage - High Level Input Voltage - Low Level Input Current - High Level Input Current - Low Level Input Frequency Input Duty Cycle	$V_{CC} = 15V$ $V_{CC} = 15V$ $V_{IL} = 11V$ $V_{CC} = 15V$ $V_{IL} = 4V$ $V_{CC} = 15V$	11	350 350 50	4	V V μA μA kHz %
TEMPERATURE RANGE Specification Operating Storage θ_{JA} T_J max		0 0 -40	220	70 70 85 150	$^{\circ}C$ $^{\circ}C$ $^{\circ}C$ $^{\circ}C/W$ $^{\circ}C$

NOTES: (1) See "High Voltage Testing" Section. (2) IMR is defined with respect to the voltage between Com 1 and Com 2 with both inputs tied to Com 1. (3) CMR is defined with respect to the input common, Com 1, only. (4) Deviation from a straight line between the end points of the output voltage. (5) Device output remains monotonic. (6) Limit referred to V_{REF1} .

PIN CONFIGURATION

Bottom View		
1		10V Ref
2		$-V_{SS1}$
3		Sense 1
4		I_{REF1}
5		+In
6		-In
7		I_{REF2}
8		Sense 2
9		$+V_{SS1}$
10		Com 1
18		V_{DD} (+5V)
19		G
20		A_0
21		A_1
22		CLK
23		RST
24		DCom 2
25		V_{CC} (+15V)
26		CKI
27		Com 2
28		Out

ABSOLUTE MAXIMUM RATINGS

Signal Input Voltage	$\pm 380V$
Analog Supply Voltage V_{CC}	18V
Digital Supply Voltage V_{DD}	7V
Voltage Across Barrier	800Vrms
Storage Temperature Range	$-45^{\circ}C$ to $+100^{\circ}C$
Lead Temperature (soldering, 10s)	$+300^{\circ}C$
Out Short Circuit Duration	Continuous to Com 2
Relative Humidity (non-condensing)	95% RH

NOTES: Stresses exceeding those listed above may cause permanent damage to the device. Exposure to absolute maximum rating conditions for extended periods may affect device reliability.

TIMING INFORMATION

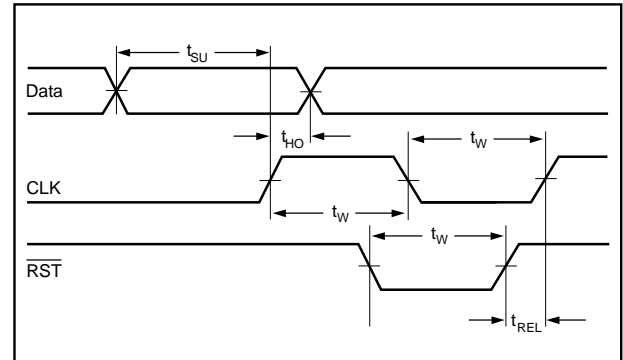

THEORY OF OPERATION

The ISC300 has no galvanic connection between the input and output sections. The differential input signal is multiplied by the programmable gain amplifier and accurately transferred across the isolation barrier to the output. The output section demodulates the signal transferred from the input section and transfers power to the input section.

ISC300 DESIGN

The ISC300 consists of:

- A filtered differential high impedance input.
- Precision matched current sources.
- Fault detect bias resistors.
- Digitally selectable internal calibration references.
- Digitally selectable gain.
- Isolation of all digital and analog signals.
- Isolated DC/DC converter.
- Synchronizable internal oscillator.
- Two isolated power supplies available for external circuitry.
- Externally available 10V reference.

INPUT SECTION

Filter

Since the ISC300 is designed to measure slowly changing processes, the input filter is set for a cut off frequency of 2Hz. This gives good noise rejection at power frequencies of 50Hz and 60Hz.

Sense Lines

The two sense lines can be configured to detect short or open circuits e.g. transducer burn out. This would be indicated by an out of range output (see Input Configuration in Applications section).

Multiplexer

The multiplexer is used to route either the measurement channel or the precision voltage references (used in system calibration) to the programmable gain amplifier.

Isolation Barrier

The isolation barrier consists of two transformers and three opto couplers. One transformer transmits the signal from the input side to the output side. The other transmits power from the output side to the input side. The opto-couplers are used to isolate the logic used for mux select, gain and reference voltage control.

Voltage Reference

The voltage reference provides 10V, 0.1V and 0V references for channel calibration. The 10V reference is also available externally.

Current References

Two matched 200µA current references are available for the excitation of RTDs or for use in external signal conditioning circuitry.

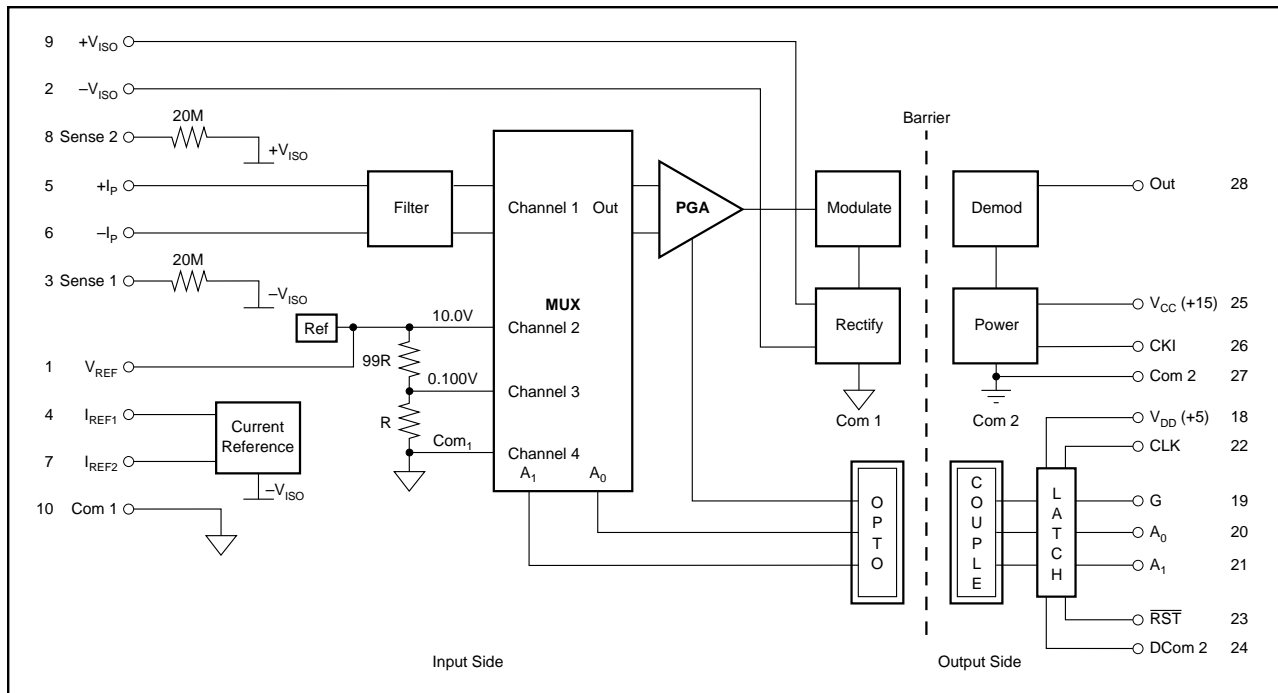

FIGURE 1. ISC300 Block Diagram.

PGA

The programmable gain amplifier allows the user to digitally select device gains of 0.5 and 50, allowing input ranges of $\pm 0.1V$ or, $\pm 10V$ full scale. When used in conjunction with the 0.1V, 10V and common references, channel calibration can be performed.

Isolated Supplies

Two 13V isolated supplies, capable of supplying 5mA each, are available to power signal conditioning circuitry.

OUTPUT SECTION

The output section passes power across the isolation barrier to provide the isolated supplies, and demodulates the signal transmitted back across the isolation barrier.

ABOUT THE BARRIER

For any isolation product, barrier integrity is of paramount importance in achieving high reliability. The ISC300 uses miniature transformers designed to give maximum isolation performance when encapsulated in a high dielectric strength material. The device is designed so that the barrier is located at the center of the package.

HIGH VOLTAGE TESTING

Burr-Brown Corporation has adopted a partial discharge test criterion that conforms to the German VDE0884 Optocoupler Standards. This method requires the measurement of minute current pulses ($< 5pC$) while applying 800Vrms, 60Hz high-voltage stress across every device isolation barrier. During a two second test partial discharge must occur five times on five separate half cycles of 60Hz, and each time occurrence must not be separated by a line period of more than four half cycles in order to produce a partial discharge fail. This confirms transient overvoltage ($1.6 \times V_{rated}$) protection without damage. Life-test results verify the absence of failure under continuous rated voltage and maximum temperature.

This new test method represents the “state-of-the-art” for nondestructive high voltage reliability testing. It is based on the effects of non-uniform fields existing in heterogeneous dielectric material during barrier degradation. In the case of void non-uniformities, electric field stress begins to ionize the void region before bridging the entire high voltage barrier.

The transient conduction of charge during and after the ionization can be detected externally as a burst of $0.01\mu s - 0.1\mu s$ current pulses that repeat on each AC voltage cycle. The minimum AC barrier voltage that initiates partial discharge is defined as the “inception voltage.” Decreasing the barrier voltage to a lower level is required before partial discharge ceases and is defined as the “extinction voltage.”

We have designed and characterized the package to yield an inception voltage in excess of 800Vrms so that transient

overvoltages below this level will not cause any damage. The extinction voltage is above 500Vrms so that even overvoltage-induced partial discharge will cease once the barrier voltage is reduced to the rated level. Older high voltage test methods relied on applying a large enough overvoltage (above rating) to catastrophically break down marginal parts, but not so high as to damage good ones. Our new partial discharge testing gives us more confidence in barrier reliability than breakdown/no breakdown criteria.

BASIC OPERATION

SIGNAL AND SUPPLY CONNECTIONS

As with any mixed signal analog and digital signal component, correct decoupling and signal routing precautions must be observed to optimize performance. The ISC300 has an internal $0.1\mu F$ decoupling capacitor at V_{CC} , so additional V_{CC} decoupling will not be necessary. However, a ground plane will minimize potential noise problems. If a low impedance ground plane is not used, Com 2 should be tied directly to the ground at the supply. It is not necessary to connect DCom 2 and Com 2 at the device. Layout practices associated with isolation signal conditioners are very important. The capacitance associated with the barrier and series resistance in the signal and reference leads must be minimized. Any capacitance across the barrier will increase AC leakage, and in conjunction with ground line resistance, may degrade high frequency IMR, see Figure 2.

INPUT CONFIGURATION

The ISC300 allows easy configuration for temperature measurement using an RTD. Figure 3 shows the basic connections for RTD operation. The two reference currents excite the resistance transducer and a current-to-voltage conversion is made corresponding to the resistance value of the transducer. If a gain of 50 is selected, a 10Ω resistance value results in a $(10 \cdot 200\mu A) \cdot 50 = 0.1V$ output; the 500Ω full scale value gives a $(500 \cdot 200\mu A) \cdot 50 = 5V$ output. The connection of the sense line allows open circuit sensor detection. An open circuit will give a corresponding $> 5.1V$ output. A short circuit will give a corresponding $< 0.1V$ output. See the Applications section under Fault Conditions for more information.

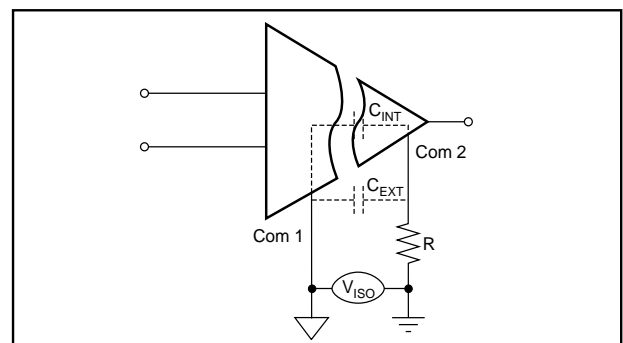

FIGURE 2. Barrier Capacitance.

Figure 4 shows the configuration for voltage measurement. A full scale input range of $\pm 10V$ can be accepted by the ISC300. The two sense lines can be connected to give open or short circuit detection. An open circuit will result in an output of $< -5.1V$ and a short circuit will give a $< 0.1V$ output. See the Applications section under Fault Conditions for more information.

Figure 7 shows a possible circuit configuration using jumpers to select voltage or RTD operation.

ISOLATED SUPPLIES

The two isolated supplies available on the input side are capable of supplying $\pm 11.5V$ min at 5mA. These can be used to provide power for external front-end circuitry for additional signal processing. When using the isolated supplies, it is necessary to decouple them as close to the device as possible. $10\mu F$ tantalum capacitors should be used. This will also improve the signal-to-noise ratio.

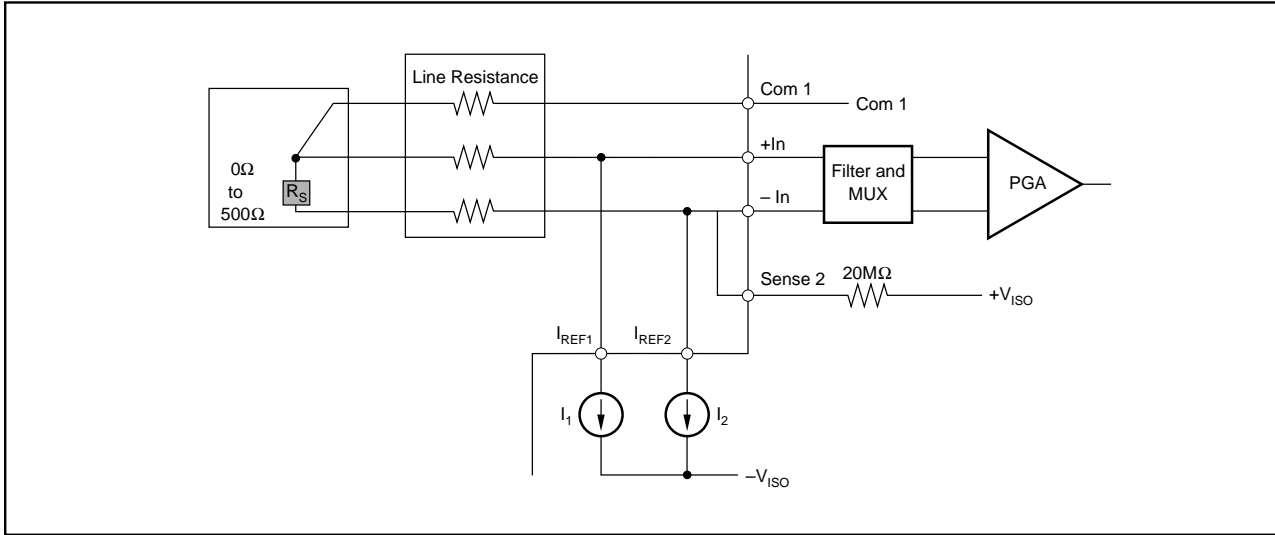

FIGURE 3. Resistance Measurement Configuration.

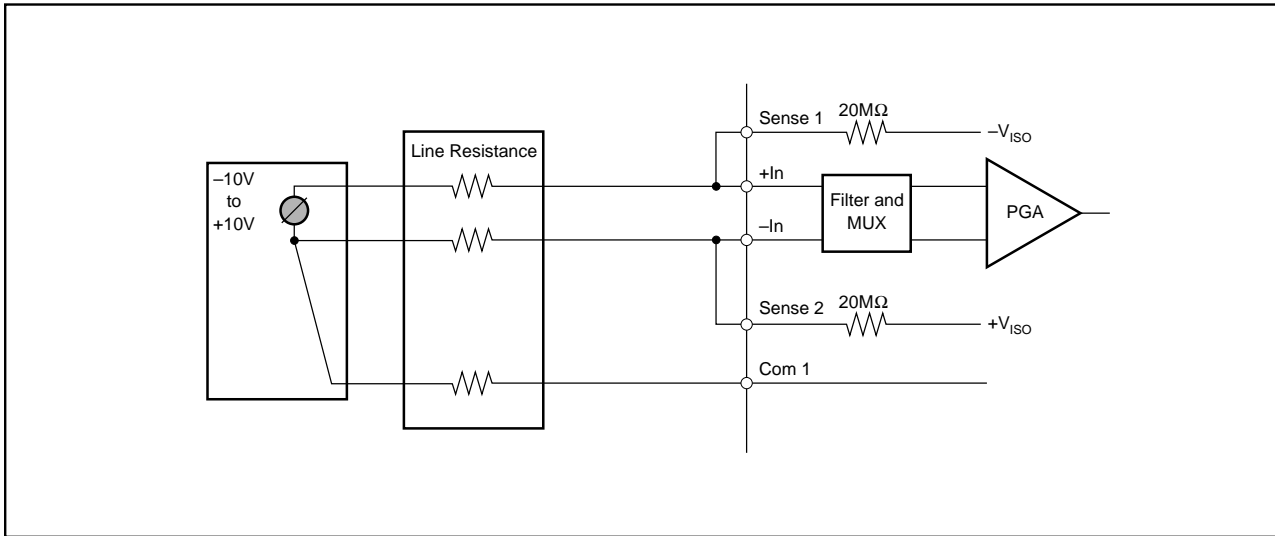

FIGURE 4. Voltage Measurement Configuration.

MEASUREMENT CHANNEL

CALIBRATION

The ISC300 is designed to allow easy system calibration using its internal voltage reference. Programming pins A₀, A₁ and G allows offset and full scale errors in gains of 0.5 and 50 to be measured.

INPUT SELECT	A ₁	A ₀	GAIN SELECT	G	SELECT AND GAIN	RST	CLK
Com 1	0	0	0.5	0	No Change	1	0
+0.1V	0	1	50	1	No Change	1	1
+10V	1	0			Latch	1	^
Signal	1	1			RESET	0	X

System calibration would typically proceed as follows:

Lab Calibration

- Set ISC300 gain.
- Set input to 0V reference, measure Offset.
- Connect external precision V reference, measure Gain.
- Remove external V reference and set input to 10V or 0.1V reference.

Offset and Gain are now calibrated to an external precision reference—record the numbers.

Field Calibration

- Set ISC300 gain.
- Set input to 0V reference, measure Offset.
- Set input to 10V or 0.1V, measure Gain.
- Recalibrate system.

SYNCHRONIZATION

As the internal modulation frequencies of several ISC300s can be marginally different, 'beat' frequencies ranging from a few Hz to a few kHz can exist in multi ISC300 applications. The internal clock (see Figure 5) starts when power is applied and runs at typically 50kHz. The ISC300 design accommodates 'internal synchronous' noise which is caused by minute timing differences, but synchronous beat frequency noise will not be strongly attenuated, especially at low frequencies if it is introduced via the power, signal or ground paths. To overcome this problem, the design allows the synchronization of each oscillator in the system to one frequency. This is done by connecting the CKI (clock in)

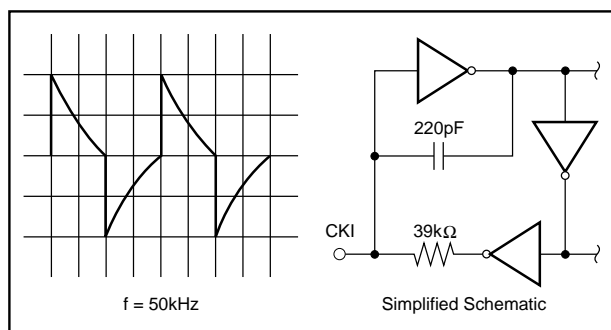

FIGURE 5. CKI Input.

pins of each ISC300 in the system together (see Figure 6). The ISC300 can also be synchronized by an external clock driver.

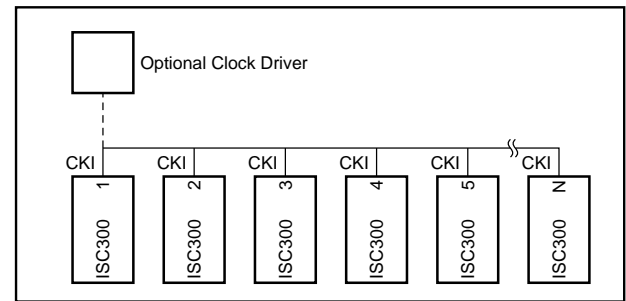

FIGURE 6. Synchronizing Multi-ISC300 Applications.

NOISE

Output noise is generated by the residual components of the 25kHz carrier that have not been removed from the signal. This noise may be reduced by adding an output low pass filter (see Figure 15 for an example of a 2 pole filter with amplification, giving a ±10V output). The filter time constants should be set below the carrier frequency. The output of the ISC300 is a switched capacitor and requires a high impedance load to prevent degradation of linearity. Loads of less than 1MΩ will cause an increase in noise at the carrier frequency and will appear as ripple in the output waveform.

APPLICATIONS

This section describes the design criteria of various applications of the ISC300.

2, 3 AND 4 WIRE RESISTANCE MEASUREMENTS

Two wire resistance measurements are prone to errors due to lead resistances. The voltage error can be significant since the voltmeter measures on the lines supplying the RTD

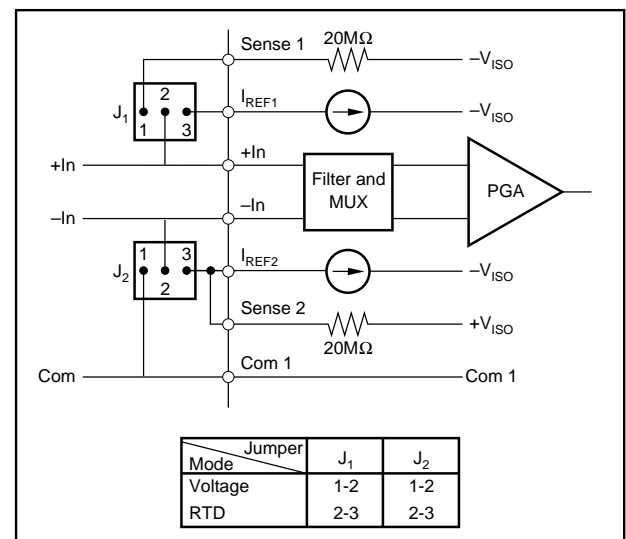

FIGURE 7. Mode Selection Jumpers.

excitation current. Four wire measurements avoid this problem by measuring the voltage generated across the RTD on a second pair of wires. Very little current flows through the voltmeter, therefore the lead resistance error contribution is negligible. Three wire resistance measurements also avoid lead length resistance errors.

In Figure 8:

$$(+In) = -r_1 (I_1 + I_2) - r_2 I_1 \quad (1)$$

$$(-In) = -r_1 (I_1 + I_2) - R_2 I_2 - r_3 I_2 \quad (2)$$

$$(1) - (2) = -r_2 I_2 + R_2 I_2 + r_3 I_2$$

Since $r_1 = r_2 = r_3$ (LEADS) and $I_1 = I_2$

$$V_{IN} = R_S I_2$$

FAULT CONDITIONS

The ISC300 can be configured to detect line or transducer faults which may occur in a system. Figures 8 to 14 show how the output of the ISC300 will reflect these various fault conditions by giving corresponding out of range outputs.

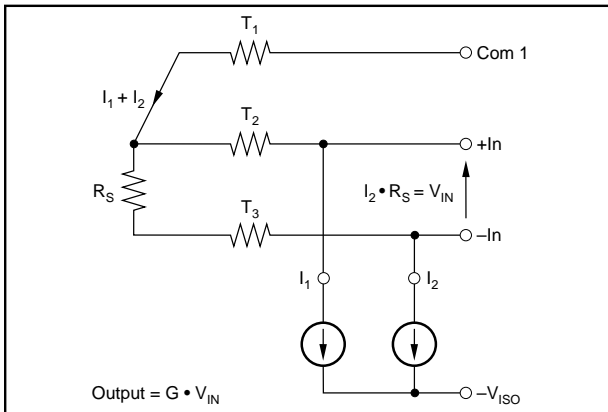

FIGURE 8. Normal Operation.

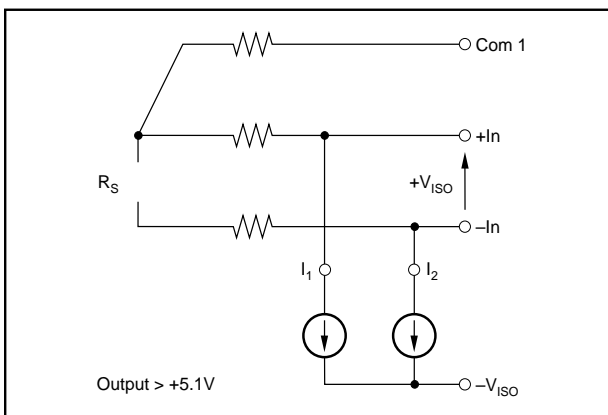

FIGURE 9. R_S Open Circuit.

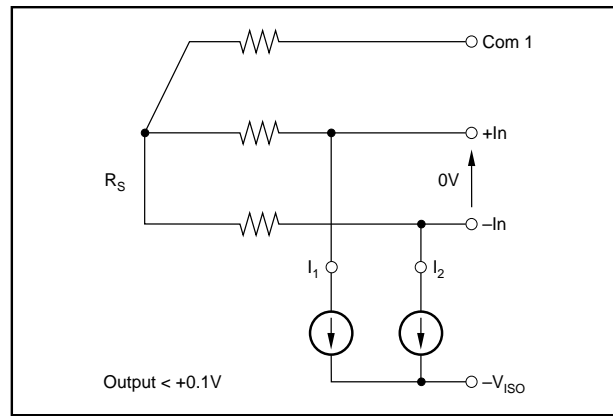

FIGURE 10. R_S Short Circuit.

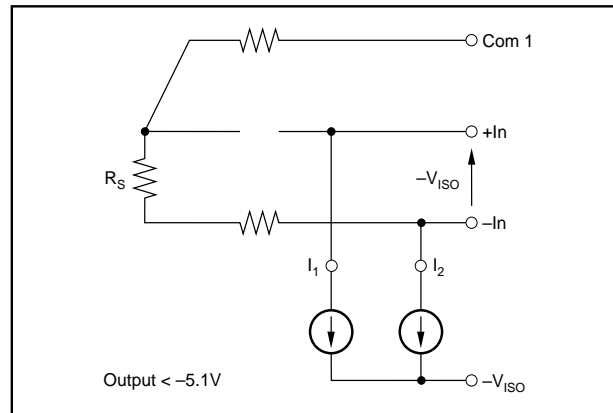

FIGURE 11. +In Open Circuit.

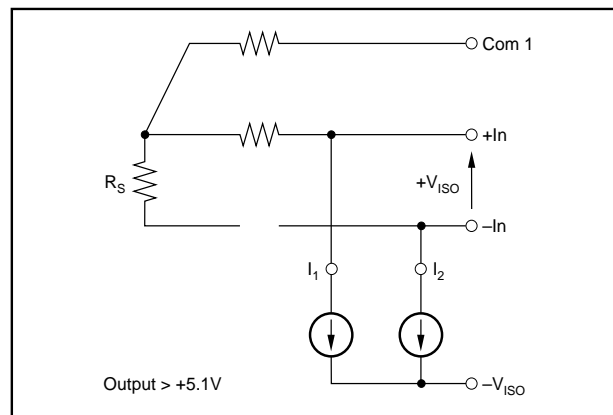

FIGURE 12. -In Open Circuit.

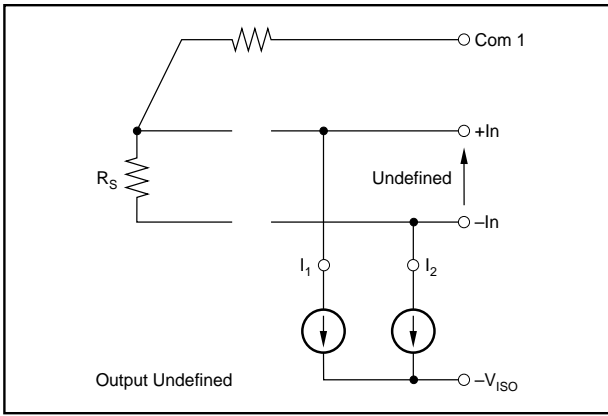

FIGURE 13. -In and +In Open Circuit.

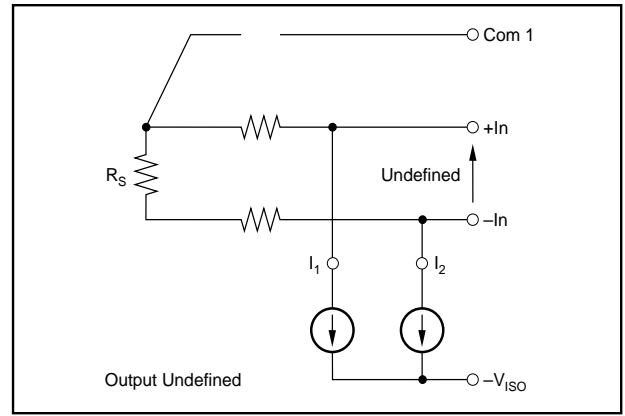

FIGURE 14. Com 1 Open Circuit.

APPLICATIONS FLEXIBILITY

ISOLATED VOLTAGE MEASUREMENT CHANNEL

Figure 15 shows the ISC300 configured for a $\pm 10V$ input. With a few external components the ISC300 can accurately convert a $\pm 10V$ input to an isolated $\pm 10V$ output with no external adjustments. The primary function of the output circuitry is to add gain to convert the $\pm 5V$ output of the ISC300 to $\pm 10V$, and to reduce output impedance. The addition of a few resistors and capacitors provides an active low pass filter with a cut off frequency of typically 200Hz. The filter response is flat to 1dB and rolls off from cut off at $-12dB$ per octave.

ISOLATED MEASUREMENT BRIDGE CIRCUIT

Figure 16 shows a measurement bridge circuit using the ISC300. All the input circuitry is powered by the ISC300 isolated supplies. The OPA1013 dual op amp is used to

excite the measurement bridge and the INA102 is used to amplify the bridge delta voltage. Connecting pins 4 and 7 together, and pins 5 and 6 together on the INA102 sets its gain to 1000.

ISOLATED 4 TO 20MA RECEIVER

In Figure 17, the ISC300 converts a 4 to 20mA current to an isolated 0 to 5V output. The 6.25Ω resistor converts the 4 to 20mA input to 0.025 to 0.125V. The 125Ω resistor in conjunction with the $200\mu A$ current source provides an offset of $-0.025V$. Fine offset and gain adjustment gives an accurate 0 to 0.1V input range.

Offset and Gain Adjustment

- Adjust R_1 for 5V change on the output corresponding to 16mA change on the input.
- Adjust R_2 with 4mA input for 0V output.

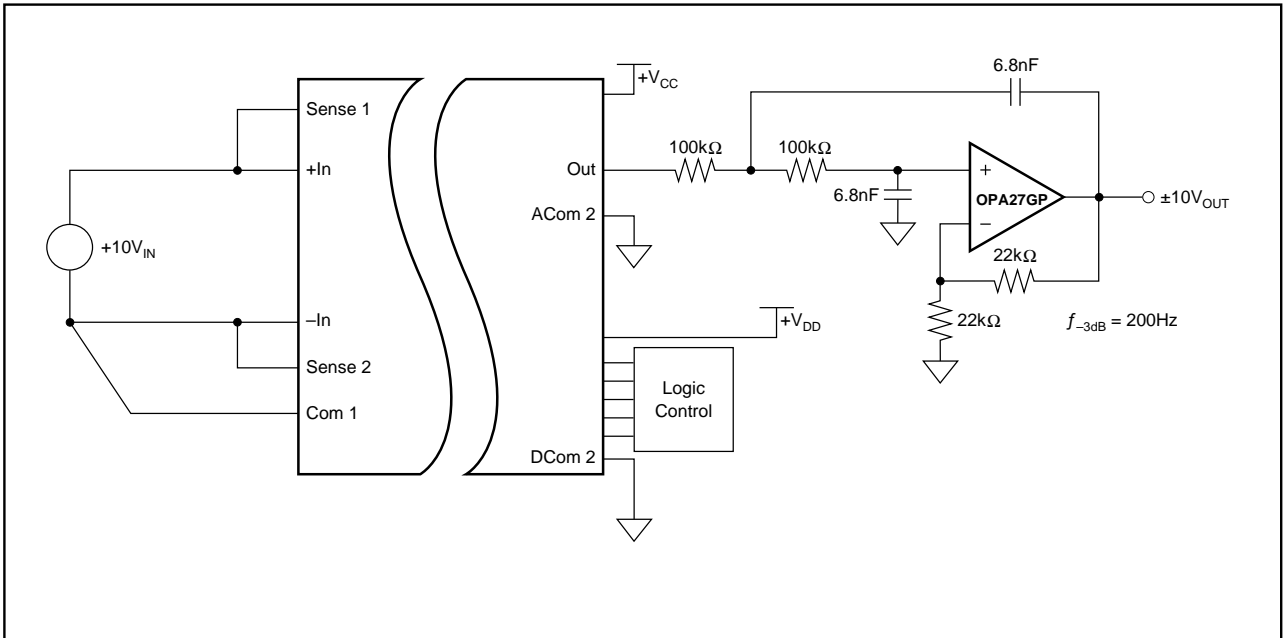

FIGURE 15. Isolated Voltage Measurement Channel with Output Filter.

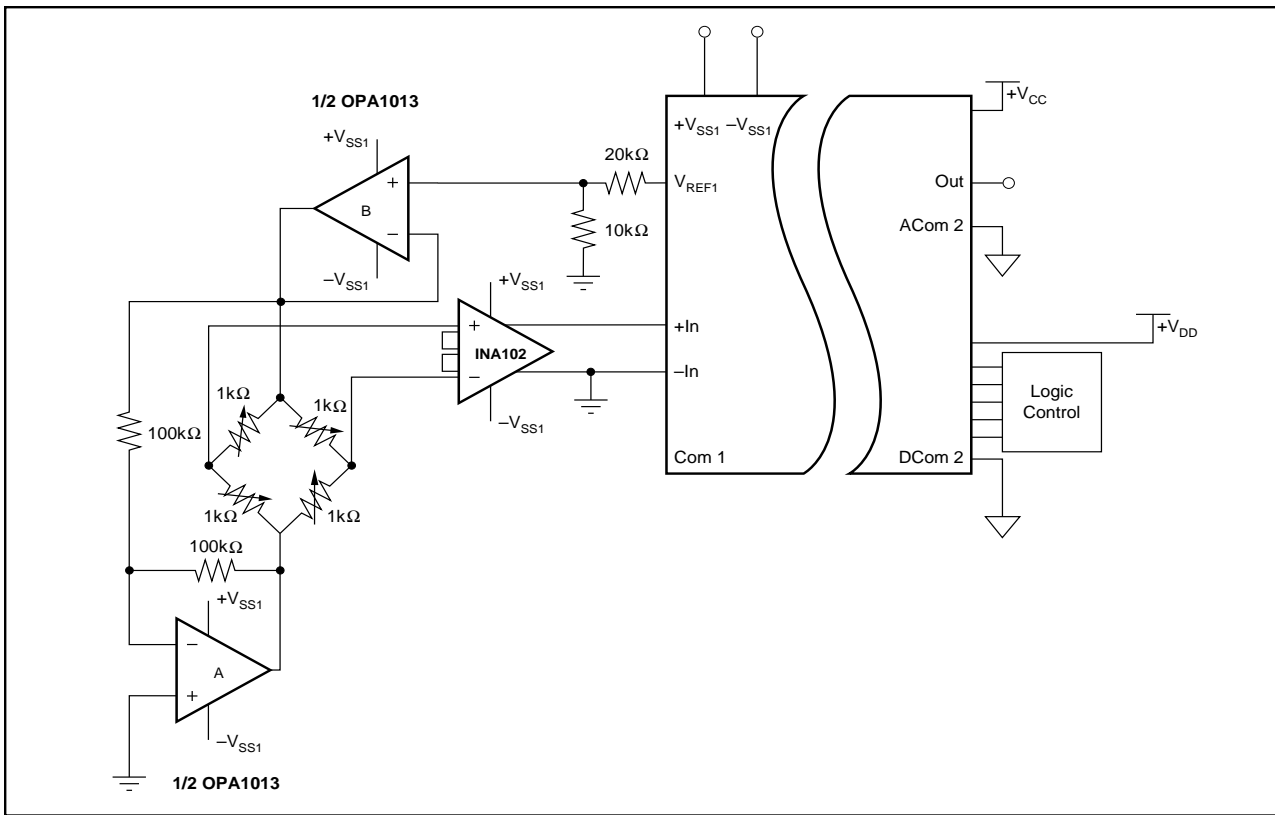

FIGURE 16. Isolated Instrument Bridge System.

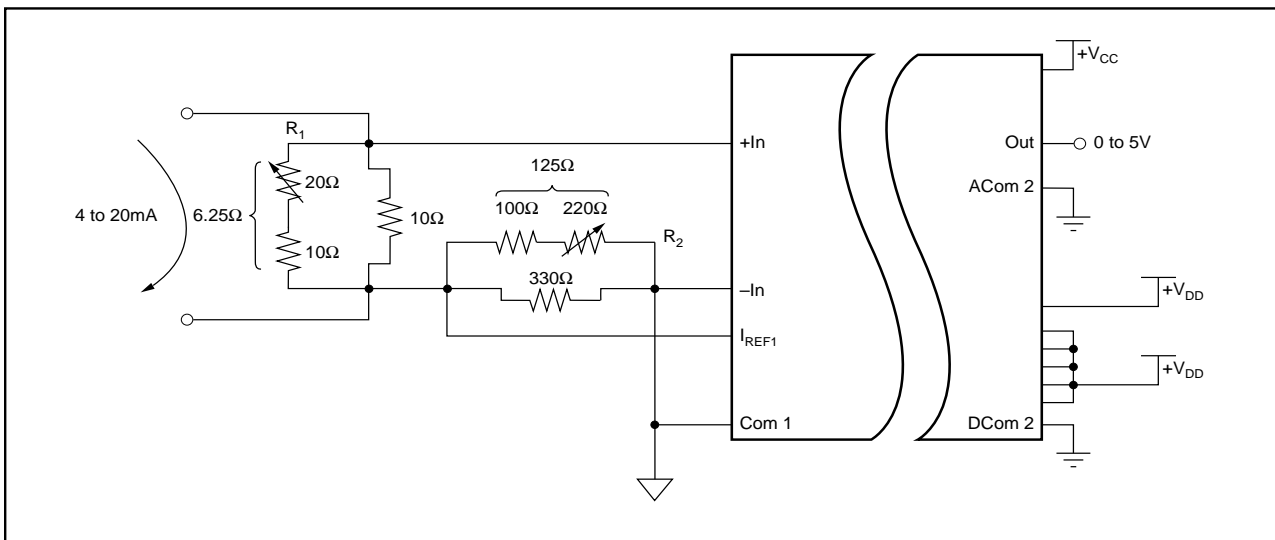

FIGURE 17. Isolated 4 to 20mA receiver (0 to 5V output).

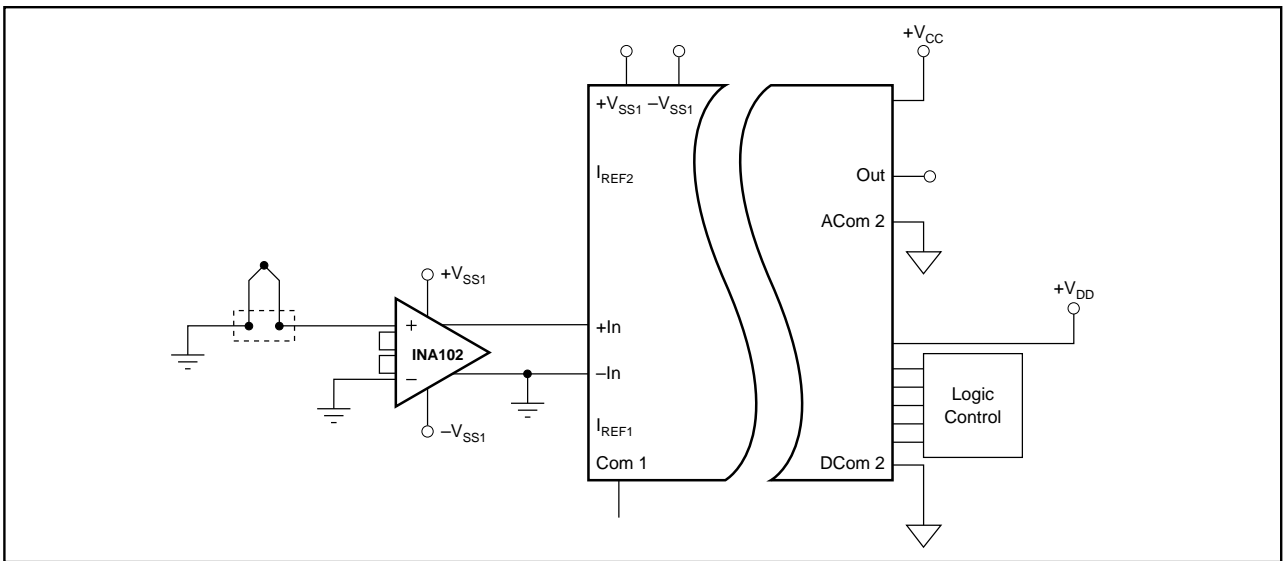

FIGURE 18. Temperature Measurement Using Thermocouple with Small Span.

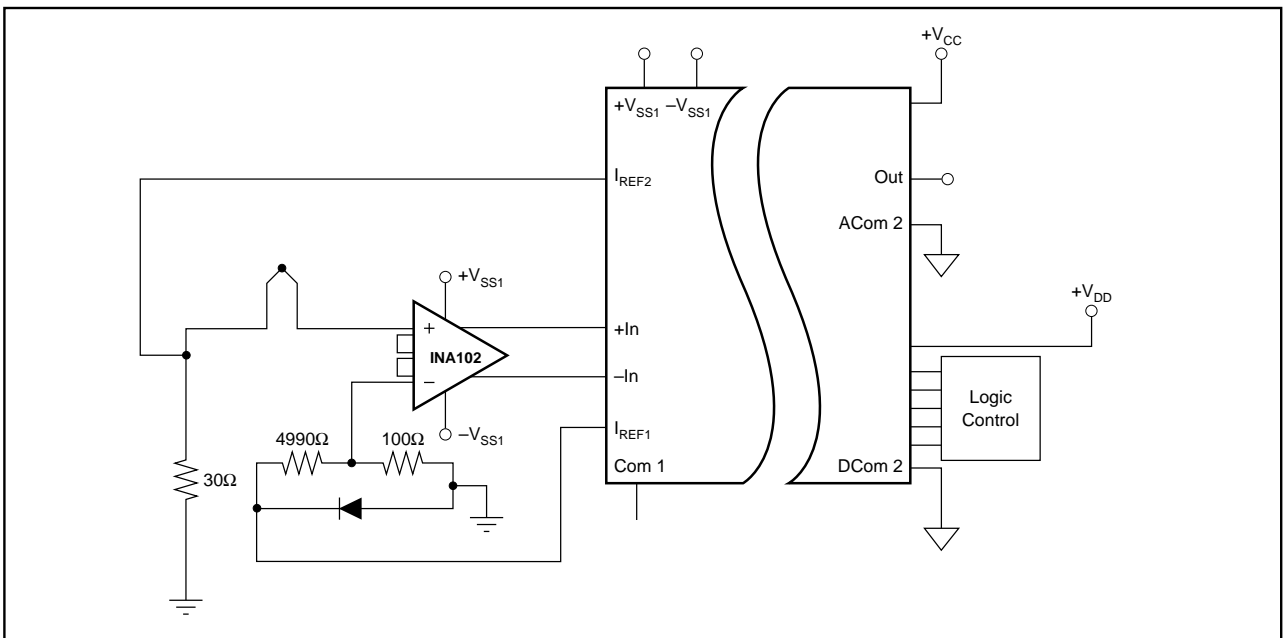

FIGURE 19. Thermocouple with Cold Junction Compensation.

The information provided herein is believed to be reliable; however, BURR-BROWN assumes no responsibility for inaccuracies or omissions. BURR-BROWN assumes no responsibility for the use of this information, and all use of such information shall be entirely at the user's own risk. Prices and specifications are subject to change without notice. No patent rights or licenses to any of the circuits described herein are implied or granted to any third party. BURR-BROWN does not authorize or warrant any BURR-BROWN product for use in life support devices and/or systems.



LittleDiode supplies new, hard to find or obsolete electronic components and semiconductors all over the world.

With over two million different components listed you are sure to find the part you need.

Feel free to visit us today at our online store:

LittleDiode.com

Looking forward to providing you with the best possible service.