

4K 2.5V Microwire® Serial EEPROM

FEATURES

- Single supply with operation down to 2.5V
- Low power CMOS technology
 - 1 mA active current (typical)
 - 1 µA standby current (maximum)
- 512 x 8 bit organization (93LC66A)
- 256 x 16 bit organization (93LC66B)
- Self-timed ERASE and WRITE cycles (including auto-erase)
- Automatic ERAL before WRAL
- Power on/off data protection circuitry
- Industry standard 3-wire serial interface
- Device status signal during ERASE/WRITE cycles
- Sequential READ function
- 1,000,000 E/W cycles guaranteed
- Data retention > 200 years
- 8-pin PDIP/SOIC and 8-pin TSSOP packages
- Available for the following temperature ranges:
 - Commercial (C): 0°C to +70°C
 - Industrial (I): -40°C to +85°C

BLOCK DIAGRAM

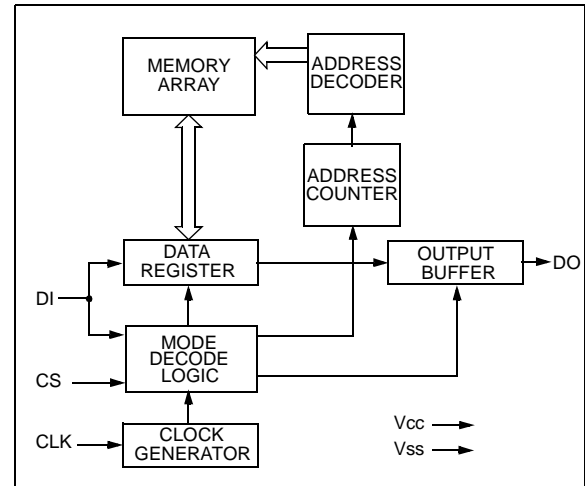

DESCRIPTION

The Microchip Technology Inc. 93LC66A/B are 4K-bit, low voltage serial Electrically Erasable PROMs. The device memory is configured as x8 (93LC66A) or x16 bits (93LC66B). Advanced CMOS technology makes these devices ideal for low power nonvolatile memory applications. The 93LC66A/B is available in standard 8-pin DIP, surface mount SOIC, and TSSOP packages. The 93LC66AX/BX are only offered in a 150-mil SOIC package.

PACKAGE TYPE

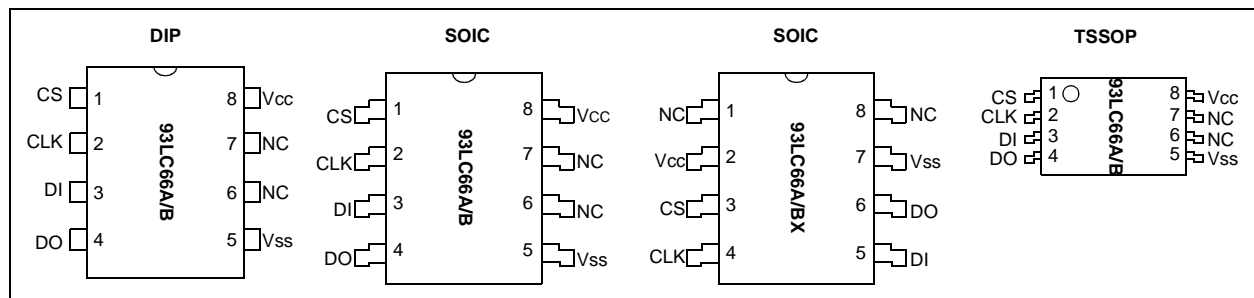

93LC66A/B

1.0 ELECTRICAL CHARACTERISTICS

1.1 Maximum Ratings*

V_{CC}7.0V
 All inputs and outputs w.r.t. V_{SS} -0.6V to V_{CC} +1.0V
 Storage temperature-65°C to +150°C
 Ambient temp. with power applied-65°C to +125°C
 Soldering temperature of leads (10 seconds)+300°C
 ESD protection on all pins4 kV

***Notice:** Stresses above those listed under "Maximum ratings" may cause permanent damage to the device. This is a stress rating only and functional operation of the device at those or any other conditions above those indicated in the operational listings of this specification is not implied. Exposure to maximum rating conditions for extended periods may affect device reliability.

TABLE 1-1 PIN FUNCTION TABLE

Name	Function
CS	Chip Select
CLK	Serial Data Clock
DI	Serial Data Input
DO	Serial Data Output
V _{SS}	Ground
NC	No Connect
V _{CC}	Power Supply

TABLE 1-2 DC AND AC ELECTRICAL CHARACTERISTICS

Parameter	Symbol	Min.	Max.	Units	Conditions
High level input voltage	V _{IH1}	2.0	V _{CC} +1	V	2.7V ≤ V _{CC} ≤ 6.0V (Note 2)
	V _{IH2}	0.7 V _{CC}	V _{CC} +1	V	V _{CC} < 2.7V
Low level input voltage	V _{IL1}	-0.3	0.8	V	V _{CC} > 2.7V (Note 2)
	V _{IL2}	-0.3	0.2 V _{CC}	V	V _{CC} < 2.7V
Low level output voltage	V _{OL1}	—	0.4	V	I _{OL} = 2.1 μA; V _{CC} = 4.5V
	V _{OL2}	—	0.2	V	I _{OL} = 100 μA; V _{CC} = V _{CC} Min.
High level output voltage	V _{OH1}	2.4	—	V	I _{OH} = -400 μA; V _{CC} = 4.5V
	V _{OH2}	V _{CC} -0.2	—	V	I _{OH} = -100 μA; V _{CC} = V _{CC} Min.
Input leakage current	I _{LI}	-10	10	μA	V _{IN} = V _{SS} to V _{CC}
Output leakage current	I _{LO}	-10	10	μA	V _{OUT} = V _{SS} to V _{CC}
Pin capacitance (all inputs/outputs)	C _{IN} , C _{OUT}	—	7	pF	V _{IN} /V _{OUT} = 0 V (Notes 1 & 2) T _{amb} = +25°C, F _{CLK} = 1 MHz
Operating current	I _{CC} read	—	1 500	mA μA	F _{CLK} = 2 MHz; V _{CC} = 6.0V F _{CLK} = 1 MHz; V _{CC} = 3.0V
	I _{CC} write	—	1.5	mA	
Standby current	I _{CCS}	—	1	μA	CS = V _{SS} ; DI = V _{SS}
Clock frequency	F _{CLK}	—	2	MHz	V _{CC} > 4.5V
		—	1	MHz	V _{CC} < 4.5V
Clock high time	T _{CKH}	250	—	ns	
Clock low time	T _{CKL}	250	—	ns	
Chip select setup time	T _{CSS}	50	—	ns	Relative to CLK
Chip select hold time	T _{CSH}	0	—	ns	Relative to CLK
Chip select low time	T _{CSL}	250	—	ns	
Data input setup time	T _{DIS}	100	—	ns	Relative to CLK
Data input hold time	T _{DIH}	100	—	ns	Relative to CLK
Data output delay time	T _{PD}	—	400	ns	C _L = 100 pF
Data output disable time	T _{CZ}	—	100	ns	C _L = 100 pF (Note 2)
Status valid time	T _{SV}	—	500	ns	C _L = 100 pF
Program cycle time	T _{WC}	—	6	ms	ERASE/WRITE mode
	T _{EC}	—	6	ms	ERAL mode
	T _{WL}	—	15	ms	WRAL mode
Endurance	—	1M	—	cycles	25°C, V _{CC} = 5.0V, Block Mode (Note 3)

Note 1: This parameter is tested at T_{amb} = 25°C and F_{clk} = 1 MHz.

Note 2: This parameter is periodically sampled and not 100% tested.

Note 3: This application is not tested but guaranteed by characterization. For endurance estimates in a specific application, please consult the Total Endurance Model which may be obtained on our website.

2.0 PIN DESCRIPTION

2.1 Chip Select (CS)

A high level selects the device; a low level deselects the device and forces it into standby mode. However, a programming cycle which is already in progress will be completed, regardless of the Chip Select (CS) input signal. If CS is brought low during a program cycle, the device will go into standby mode as soon as the programming cycle is completed.

CS must be low for 250 ns minimum (T_{CSL}) between consecutive instructions. If CS is low, the internal control logic is held in a RESET status.

2.2 Serial Clock (CLK)

The Serial Clock (CLK) is used to synchronize the communication between a master device and the 93LC66A/B. Opcode, address, and data bits are clocked in on the positive edge of CLK. Data bits are also clocked out on the positive edge of CLK.

CLK can be stopped anywhere in the transmission sequence (at high or low level) and can be continued anytime with respect to clock high time (T_{CKH}) and clock low time (T_{CKL}). This gives the controlling master freedom in preparing opcode, address, and data.

CLK is a "Don't Care" if CS is low (device deselected). If CS is high, but a START condition has not been detected, any number of clock cycles can be received by the device without changing its status (i.e., waiting for a START condition).

CLK cycles are not required during the self-timed WRITE (i.e., auto ERASE/WRITE) cycle.

After detection of a START condition the specified number of clock cycles (respectively low to high transitions of CLK) must be provided. These clock cycles are required to clock in all required opcode, address, and data bits before an instruction is executed (Table 2-1 and Table 2-2). CLK and DI then become don't care inputs waiting for a new START condition to be detected.

2.3 Data In (DI)

Data In (DI) is used to clock in a START bit, opcode, address, and data synchronously with the CLK input.

2.4 Data Out (DO)

Data Out (DO) is used in the READ mode to output data synchronously with the CLK input (T_{PD} after the positive edge of CLK).

This pin also provides READY/ $\overline{\text{BUSY}}$ status information during ERASE and WRITE cycles. READY/ $\overline{\text{BUSY}}$ status information is available on the DO pin if CS is brought high after being low for minimum chip select low time (T_{CSL}) and an ERASE or WRITE operation has been initiated.

The status signal is not available on DO, if CS is held low during the entire ERASE or WRITE cycle. In this case, DO is in the HIGH-Z mode. If status is checked after the ERASE/WRITE cycle, the data line will be high to indicate the device is ready.

TABLE 2-1 INSTRUCTION SET FOR 93LC66A

Instruction	SB	Opcode	Address	Data In	Data Out	Req. CLK Cycles
ERASE	1	11	A8 A7 A6 A5 A4 A3 A2 A1 A0	—	(RDY/ $\overline{\text{BSY}}$)	12
ERAL	1	00	1 0 X X X X X X X	—	(RDY/ $\overline{\text{BSY}}$)	12
EWDS	1	00	0 0 X X X X X X X	—	HIGH-Z	12
EWEN	1	00	1 1 X X X X X X X	—	HIGH-Z	12
READ	1	10	A8 A7 A6 A5 A4 A3 A2 A1 A0	—	D7 - D0	20
WRITE	1	01	A8 A7 A6 A5 A4 A3 A2 A1 A0	D7 - D0	(RDY/ $\overline{\text{BSY}}$)	20
WRAL	1	00	0 1 X X X X X X X	D7 - D0	(RDY/ $\overline{\text{BSY}}$)	20

TABLE 2-2 INSTRUCTION SET FOR 93LC66B

Instruction	SB	Opcode	Address	Data In	Data Out	Req. CLK Cycles
ERASE	1	11	A7 A6 A5 A4 A3 A2 A1 A0	—	(RDY/ $\overline{\text{BSY}}$)	11
ERAL	1	00	1 0 X X X X X X X	—	(RDY/ $\overline{\text{BSY}}$)	11
EWDS	1	00	0 0 X X X X X X X	—	HIGH-Z	11
EWEN	1	00	1 1 X X X X X X X	—	HIGH-Z	11
READ	1	10	A7 A6 A5 A4 A3 A2 A1 A0	—	D15 - D0	27
WRITE	1	01	A7 A6 A5 A4 A3 A2 A1 A0	D15 - D0	(RDY/ $\overline{\text{BSY}}$)	27
WRAL	1	00	0 1 X X X X X X X	D15 - D0	(RDY/ $\overline{\text{BSY}}$)	27

3.0 FUNCTIONAL DESCRIPTION

Instructions, addresses, and write data are clocked into the DI pin on the rising edge of the clock (CLK). The DO pin is normally held in a HIGH-Z state except when reading data from the device, or when checking the READY/BUSY status during a programming operation. The READY/BUSY status can be verified during an ERASE/WRITE operation by polling the DO pin; DO low indicates that programming is still in progress, while DO high indicates the device is ready. The DO will enter the HIGH-Z state on the falling edge of the CS.

3.1 START Condition

The START bit is detected by the device if CS and DI are both high with respect to the positive edge of CLK for the first time.

Before a START condition is detected, CS, CLK, and DI may change in any combination (except to that of a START condition), without resulting in any device operation (ERASE, ERAL, EWDS, EWEN, READ, WRITE, and WRAL). As soon as CS is high, the device is no longer in the standby mode.

An instruction following a START condition will only be executed if the required amount of opcodes, addresses, and data bits for any particular instruction is clocked in.

After execution of an instruction (i.e., clock in or out of the last required address or data bit) CLK and DI become don't care bits until a new START condition is detected.

3.2 Data In (DI) Data Out (DO)

It is possible to connect the Data In (DI) and Data Out (DO) pins together. However, with this configuration, if A0 is a logic-high level, it is possible for a "bus conflict" to occur during the "dummy zero" that precedes the READ operation. Under such a condition the voltage level seen at Data Out is undefined and will depend upon the relative impedances of Data Out and the signal source driving A0. The higher the current sourcing capability of A0, the higher the voltage at the Data Out pin.

3.3 Data Protection

During power-up, all programming modes of operation are inhibited until VCC has reached a level greater than 2.2V. During power-down, the source data protection circuitry acts to inhibit all programming modes when Vcc has fallen below 2.2V at nominal conditions.

The ERASE/WRITE Disable (EWDS) and ERASE/WRITE Enable (EWEN) commands give additional protection against accidentally programming during normal operation.

After power-up, the device is automatically in the EWDS mode. Therefore, an EWEN instruction must be performed before any ERASE or WRITE instruction can be executed.

FIGURE 3-1: SYNCHRONOUS DATA TIMING

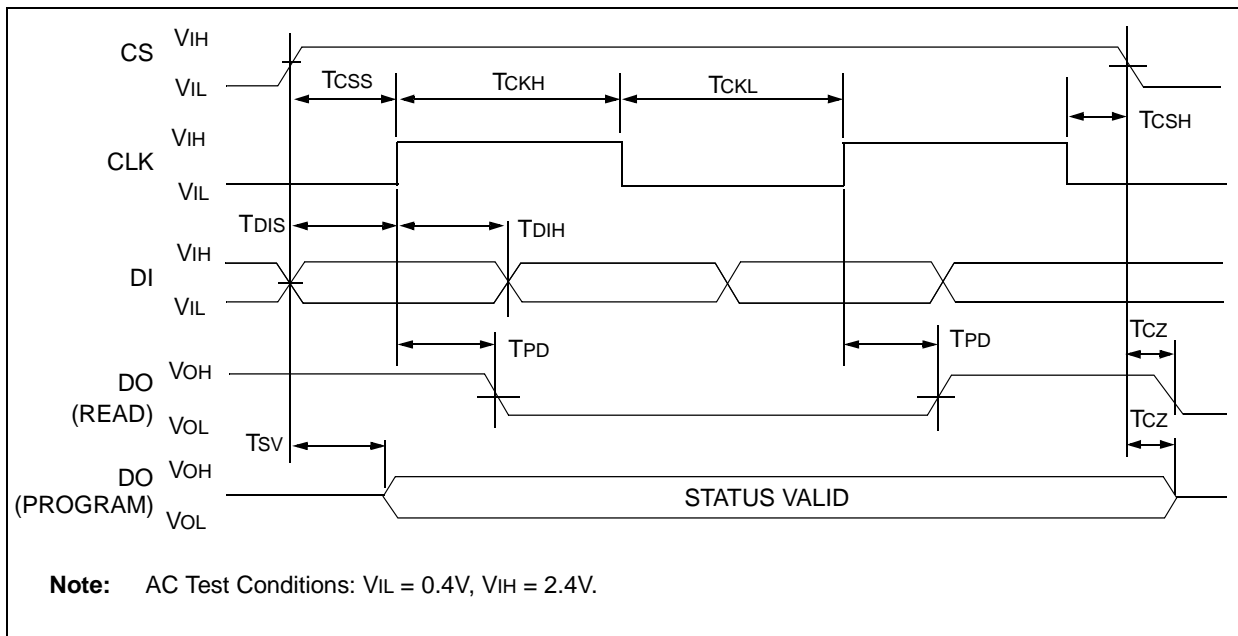

3.4 ERASE

The ERASE instruction forces all data bits of the specified address to the logical "1" state. CS is brought low following the loading of the last address bit. This falling edge of the CS pin initiates the self-timed programming cycle.

The DO pin indicates the READY/ $\overline{\text{BUSY}}$ status of the device if CS is brought high after a minimum of 250 ns low (T_{CSL}). DO at logical "0" indicates that programming is still in progress. DO at logical "1" indicates that the register at the specified address has been erased and the device is ready for another instruction.

3.5 Erase All (ERAL)

The Erase All (ERAL) instruction will erase the entire memory array to the logical "1" state. The ERAL cycle is identical to the ERASE cycle except for the different opcode. The ERAL cycle is completely self-timed and commences at the falling edge of the CS. Clocking of the CLK pin is not necessary after the device has entered the ERAL cycle.

The DO pin indicates the READY/ $\overline{\text{BUSY}}$ status of the device if CS is brought high after a minimum of 250 ns low (T_{CSL}) and before the entire ERAL cycle is complete.

FIGURE 3-2: ERASE TIMING

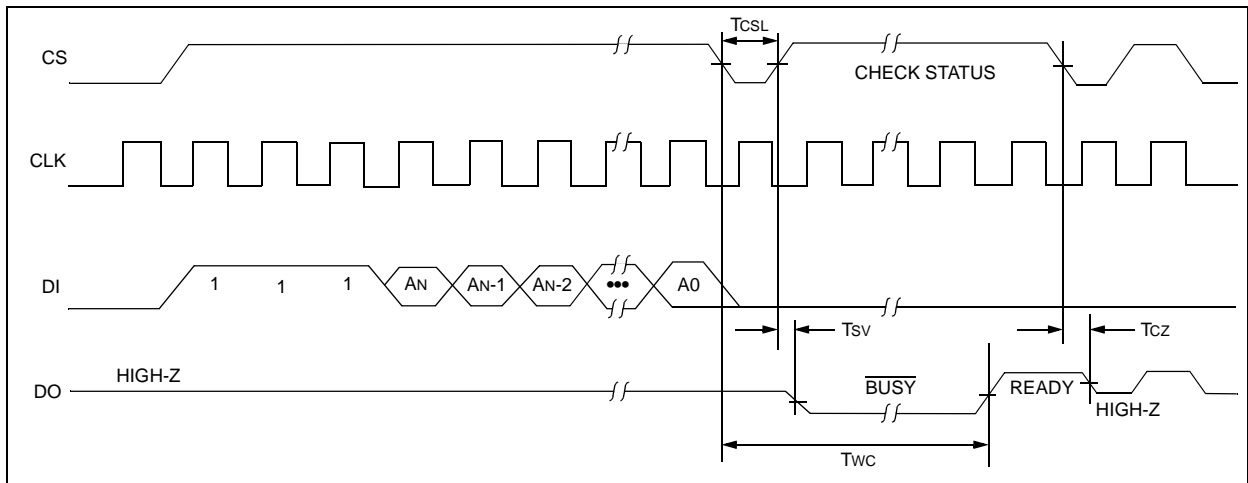
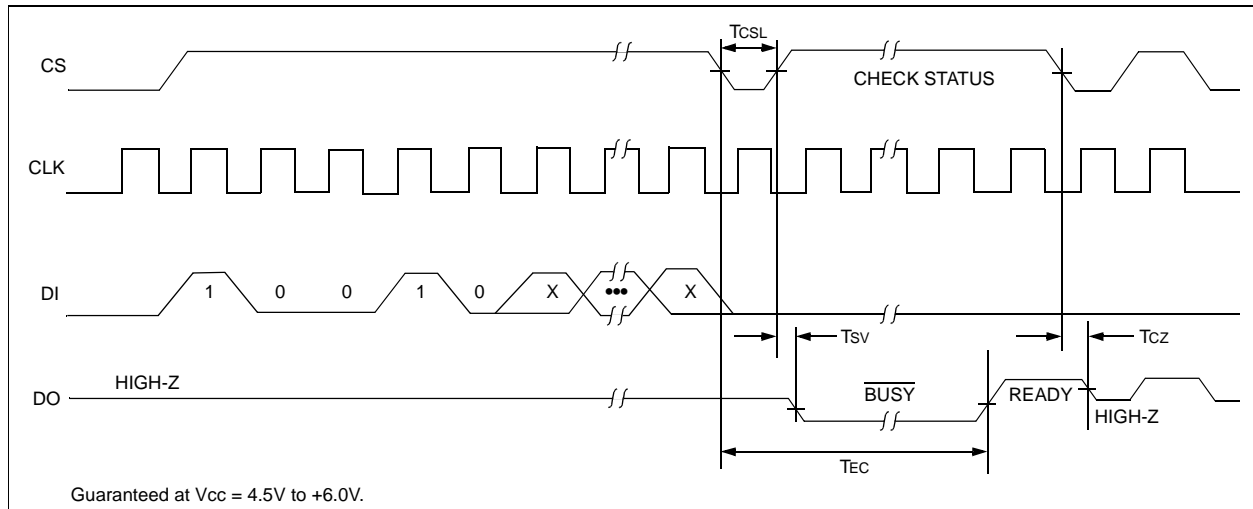

FIGURE 3-3: ERAL TIMING



93LC66A/B

3.6 ERASE/WRITE Disable and Enable (EWDS/EWEN)

The 93LC66A/B powers up in the ERASE/WRITE Disable (EWDS) state. All programming modes must be preceded by an ERASE/WRITE Enable (EWEN) instruction. Once the EWEN instruction is executed, programming remains enabled until an EWDS instruction is executed or Vcc is removed from the device. To protect against accidental data disturbance, the EWDS instruction can be used to disable all ERASE/WRITE functions and should follow all programming operations. Execution of a READ instruction is independent of both the EWDS and EWEN instructions.

3.7 READ

The READ instruction outputs the serial data of the addressed memory location on the DO pin. A dummy zero bit precedes the 8-bit (93LC66A) or 16-bit (93LC66B) output string. The output data bits will toggle on the rising edge of the CLK and are stable after the specified time delay (TPD). Sequential read is possible when CS is held high. The memory data will automatically cycle to the next register and output sequentially.

FIGURE 3-4: EWDS TIMING

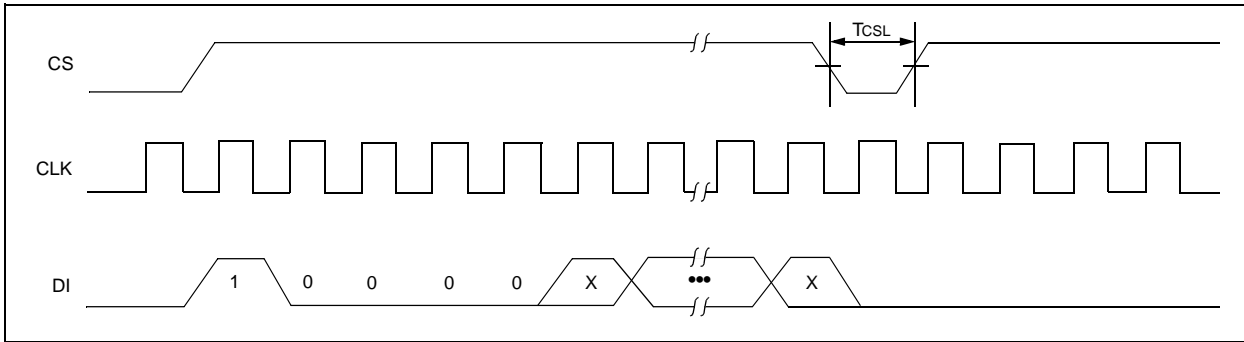

FIGURE 3-5: EWEN TIMING

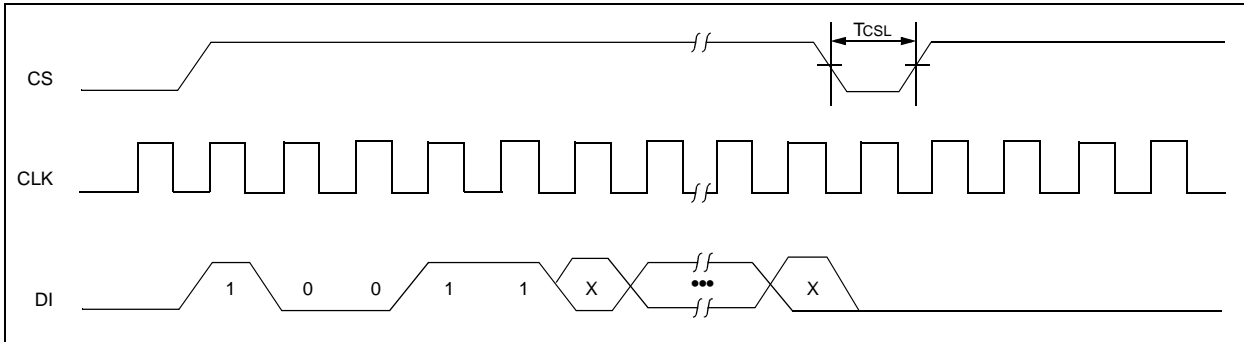
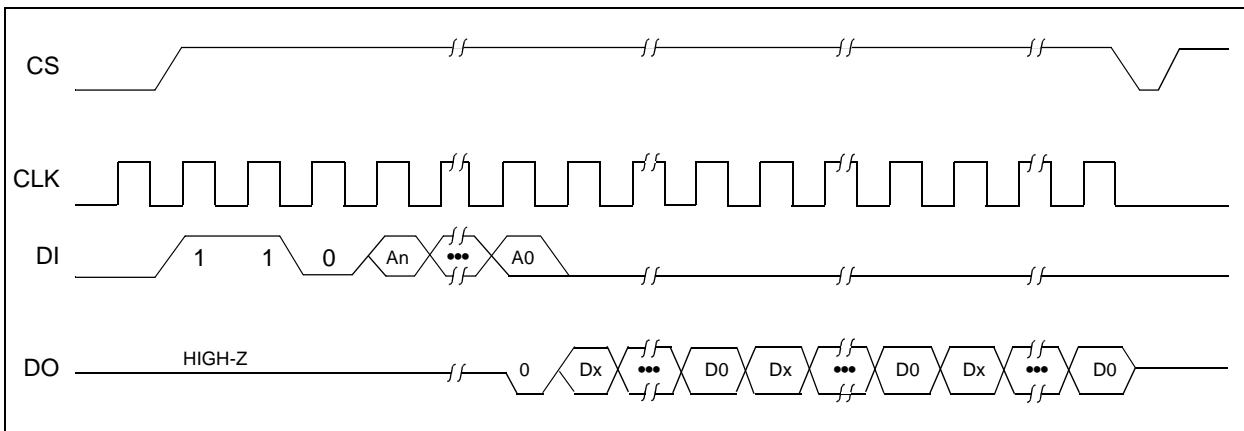

FIGURE 3-6: READ TIMING



3.8 WRITE

The WRITE instruction is followed by 8 bits (93LC66A) or 16 bits (93LC66B) of data which are written into the specified address. After the last data bit is put on the DI pin, the falling edge of CS initiates the self-timed auto-erase and programming cycle.

The DO pin indicates the $\overline{\text{READY}}/\overline{\text{BUSY}}$ status of the device, if CS is brought high after a minimum of 250 ns low (T_{CSL}) and before the entire write cycle is complete. DO at logical "0" indicates that programming is still in progress. DO at logical "1" indicates that the register at the specified address has been written with the data specified and the device is ready for another instruction.

3.9 Write All (WRAL)

The Write All (WRAL) instruction will write the entire memory array with the data specified in the command. The WRAL cycle is completely self-timed and commences at the falling edge of the CS. Clocking of the CLK pin is not necessary after the device has entered the WRAL cycle. The WRAL command does include an automatic ERAL cycle for the device. Therefore, the WRAL instruction does not require an ERAL instruction, but the chip must be in the EWEN status.

The DO pin indicates the $\overline{\text{READY}}/\overline{\text{BUSY}}$ status of the device if CS is brought high after a minimum of 250 ns low (T_{CSL}).

FIGURE 3-7: WRITE TIMING

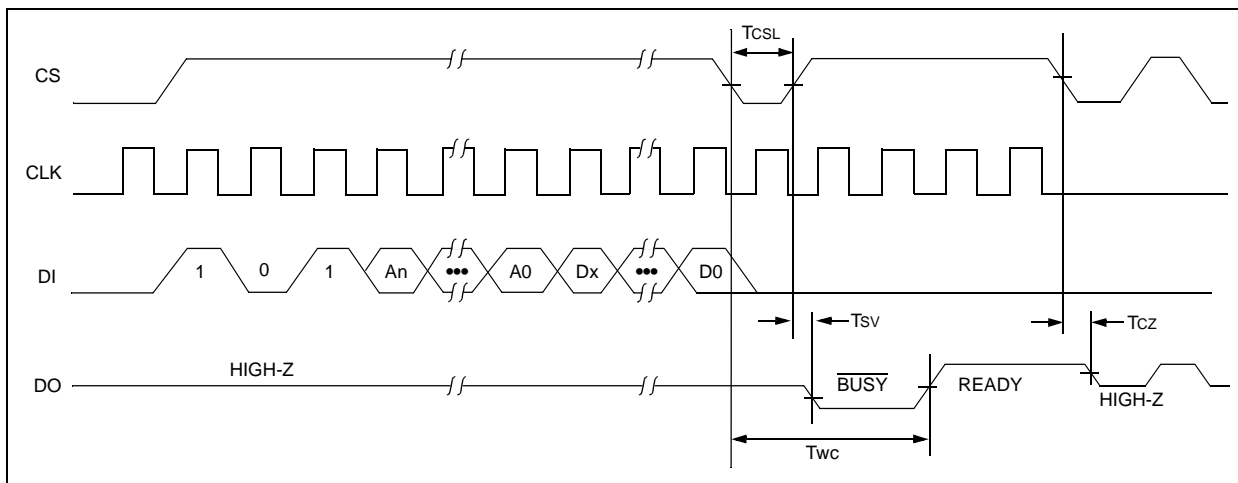
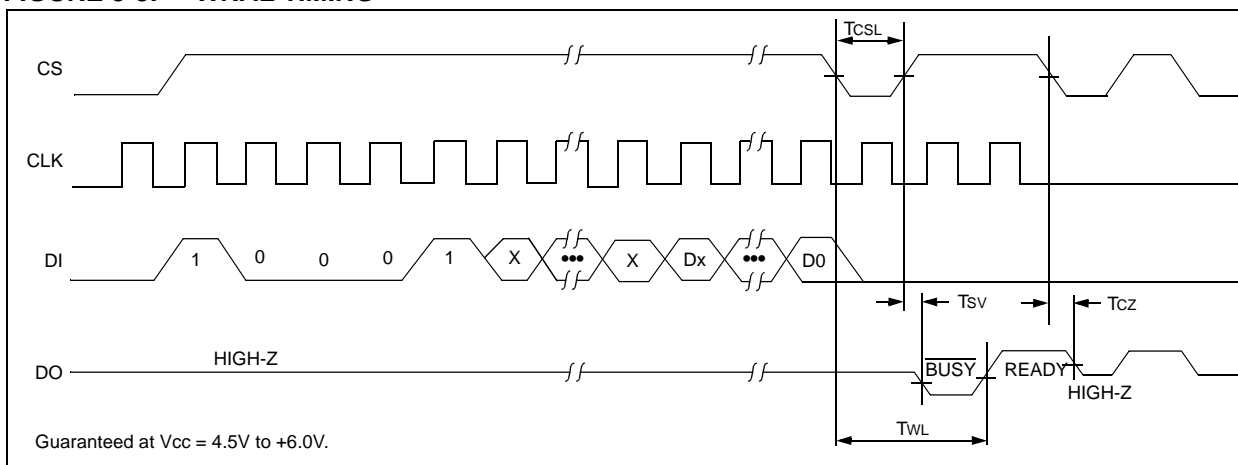

FIGURE 3-8: WRAL TIMING



93LC66A/B

NOTES:

NOTES:

93LC66A/B

NOTES:

93LC66A/B PRODUCT IDENTIFICATION SYSTEM

To order or obtain information, e.g., on pricing or delivery, refer to the factory or the listed sales office.

93LC66A/B — /P 	Package: P = Plastic DIP (300 mil Body), 8-lead SN = Plastic SOIC (150 mil Body), 8-lead SM = Plastic SOIC (208 mil Body), 8-lead ST = TSSOP, 8-lead
	Temperature Range: Blank = 0°C to +70°C I = -40°C to +85°C
	Device: 93LC66A 4K Microwire Serial EEPROM (x8) 93LC66AT 4K Microwire Serial EEPROM (x8) Tape and Reel 93LC66AX 4K Microwire Serial EEPROM (x8) in alternate pinout (SN only) 93LC66AXT 4K Microwire Serial EEPROM (x8) in alternate pinout, Tape and Reel (SN only) 93LC66B 4K Microwire Serial EEPROM (x16) 93LC66BT 4K Microwire Serial EEPROM (x16) Tape and Reel 93LC66BX 4K Microwire Serial EEPROM (x16) in alternate pinout (SN only) 93LC66BXT 4K Microwire Serial EEPROM (x16) in alternate pinout, Tape and Reel (SN only)

Sales and Support

Data Sheets

Products supported by a preliminary Data Sheet may have an errata sheet describing minor operational differences and recommended workarounds. To determine if an errata sheet exists for a particular device, please contact one of the following:

1. Your local Microchip sales office
2. The Microchip Corporate Literature Center U.S. FAX: (480) 792-7277
3. The Microchip Worldwide Site (www.microchip.com)

Please specify which device, revision of silicon and Data Sheet (include Literature #) you are using.

New Customer Notification System

Register on our web site (www.microchip.com/cn) to receive the most current information on our products.



WORLDWIDE SALES AND SERVICE

AMERICAS

Corporate Office

2355 West Chandler Blvd.
Chandler, AZ 85224-6199
Tel: 480-792-7200 Fax: 480-792-7277
Technical Support: 480-792-7627
Web Address: <http://www.microchip.com>

Rocky Mountain

2355 West Chandler Blvd.
Chandler, AZ 85224-6199
Tel: 480-692-7966 Fax: 480-792-7456

Atlanta

500 Sugar Mill Road, Suite 200B
Atlanta, GA 30350
Tel: 770-640-0034 Fax: 770-640-0307

Boston

2 Lan Drive, Suite 120
Westford, MA 01886
Tel: 978-692-3848 Fax: 978-692-3821

Chicago

333 Pierce Road, Suite 180
Itasca, IL 60143
Tel: 630-285-0071 Fax: 630-285-0075

Dallas

4570 Westgrove Drive, Suite 160
Addison, TX 75001
Tel: 972-818-7423 Fax: 972-818-2924

Dayton

Two Prestige Place, Suite 130
Miamisburg, OH 45342
Tel: 937-291-1654 Fax: 937-291-9175

Detroit

Tri-Atria Office Building
32255 Northwestern Highway, Suite 190
Farmington Hills, MI 48334
Tel: 248-538-2250 Fax: 248-538-2260

Los Angeles

18201 Von Karman, Suite 1090
Irvine, CA 92612
Tel: 949-263-1888 Fax: 949-263-1338

New York

150 Motor Parkway, Suite 202
Hauppauge, NY 11788
Tel: 631-273-5305 Fax: 631-273-5335

San Jose

Microchip Technology Inc.
2107 North First Street, Suite 590
San Jose, CA 95131
Tel: 408-436-7950 Fax: 408-436-7955

Toronto

6285 Northam Drive, Suite 108
Mississauga, Ontario L4V 1X5, Canada
Tel: 905-673-0699 Fax: 905-673-6509

ASIA/PACIFIC

China - Beijing

Microchip Technology Beijing Office
Unit 915
New China Hong Kong Manhattan Bldg.
No. 6 Chaoyangmen Beidajie
Beijing, 100027, No. China
Tel: 86-10-85282100 Fax: 86-10-85282104

China - Shanghai

Microchip Technology Shanghai Office
Room 701, Bldg. B
Far East International Plaza
No. 317 Xian Xia Road
Shanghai, 200051
Tel: 86-21-6275-5700 Fax: 86-21-6275-5060

Hong Kong

Microchip Asia Pacific
RM 2101, Tower 2, Metroplaza
223 Hing Fong Road
Kwai Fong, N.T., Hong Kong
Tel: 852-2401-1200 Fax: 852-2401-3431

India

Microchip Technology Inc.
India Liaison Office
Divyasree Chambers
1 Floor, Wing A (A3/A4)
No. 11, O'Shaughnessy Road
Bangalore, 560 025, India
Tel: 91-80-2290061 Fax: 91-80-2290062

Japan

Microchip Technology Intl. Inc.
Benex S-1 6F
3-18-20, Shinyokohama
Kohoku-Ku, Yokohama-shi
Kanagawa, 222-0033, Japan
Tel: 81-45-471-6166 Fax: 81-45-471-6122

Korea

Microchip Technology Korea
168-1, Youngbo Bldg. 3 Floor
Samsung-Dong, Kangnam-Ku
Seoul, Korea
Tel: 82-2-554-7200 Fax: 82-2-558-5934

ASIA/PACIFIC (continued)

Singapore

Microchip Technology Singapore Pte Ltd.
200 Middle Road
#07-02 Prime Centre
Singapore, 188980
Tel: 65-334-8870 Fax: 65-334-8850

Taiwan

Microchip Technology Taiwan
11F-3, No. 207
Tung Hua North Road
Taipei, 105, Taiwan
Tel: 886-2-2717-7175 Fax: 886-2-2545-0139

EUROPE

Denmark

Microchip Technology Denmark ApS
Regus Business Centre
Lautrup hofj 1-3
Ballerup DK-2750 Denmark
Tel: 45 4420 9895 Fax: 45 4420 9910

France

Arizona Microchip Technology SARL
Parc d'Activite du Moulin de Massy
43 Rue du Saule Trapu
Batiment A - 1er Etage
91300 Massy, France
Tel: 33-1-69-53-63-20 Fax: 33-1-69-30-90-79

Germany

Arizona Microchip Technology GmbH
Gustav-Heinemann Ring 125
D-81739 Munich, Germany
Tel: 49-89-627-144 0 Fax: 49-89-627-144-44

Italy

Arizona Microchip Technology SRL
Centro Direzionale Colleoni
Palazzo Taurus 1 V. Le Colleoni 1
20041 Agrate Brianza
Milan, Italy
Tel: 39-039-65791-1 Fax: 39-039-6899883

United Kingdom

Arizona Microchip Technology Ltd.
505 Eskdale Road
Winnersh Triangle
Wokingham
Berkshire, England RG41 5TU
Tel: 44 118 921 5869 Fax: 44-118 921-5820

10/01/00

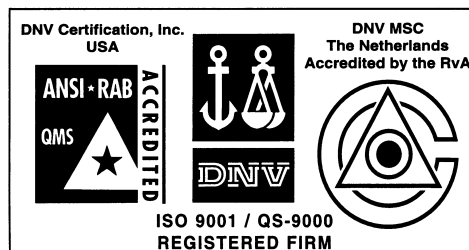

Microchip received QS-9000 quality system certification for its worldwide headquarters, design and wafer fabrication facilities in Chandler and Tempe, Arizona in July 1999. The Company's quality system processes and procedures are QS-9000 compliant for its PICmicro® 8-bit MCUs, KEELoc® code hopping devices, Serial EEPROMs and microperipheral products. In addition, Microchip's quality system for the design and manufacture of development systems is ISO 9001 certified.

All rights reserved. © 2000 Microchip Technology Incorporated. Printed in the USA. 12/00 Printed on recycled paper.

Information contained in this publication regarding device applications and the like is intended through suggestion only and may be superseded by updates. It is your responsibility to ensure that your application meets with your specifications. No representation or warranty is given and no liability is assumed by Microchip Technology Incorporated with respect to the accuracy or use of such information, or infringement of patents or other intellectual property rights arising from such use or otherwise. Use of Microchip's products as critical components in life support systems is not authorized except with express written approval by Microchip. No licenses are conveyed, implicitly or otherwise, except as maybe explicitly expressed herein, under any intellectual property rights. The Microchip logo and name are registered trademarks of Microchip Technology Inc. in the U.S.A. and other countries. All rights reserved. All other trademarks mentioned herein are the property of their respective companies.

This datasheet has been downloaded from:

www.DatasheetCatalog.com

Datasheets for electronic components.



LittleDiode supplies new, hard to find or obsolete electronic components and semiconductors all over the world.

With over two million different components listed you are sure to find the part you need.

Feel free to visit us today at our online store:

LittleDiode.com

Looking forward to providing you with the best possible service.