

AN7170

18W Audio Power Amplifier Circuit

■ Overview

The AN7170 is an integrated circuit manufactured by high voltage process designed for power amplifier of bus, track amplifier. Wide operating supply voltage range with output of 18W at 26.4V. It can be widely used for bus, truck amp., car stereo, home entertainment stereo set and TV sound multiplex output.

■ Features

- High output power : $P_O = 18W$
- High surge voltage : $V_{CC(surge)} = 60V$ (max.)
- Wide supply voltage range : $V_{CC(opr)} = 8 \sim 35V$
- Incorporating protection circuits (overvoltage, overcurrent, temperature, load short)
- Incorporating automatic operating point stabilizer circuit
- Low distortion, low 1/f noise

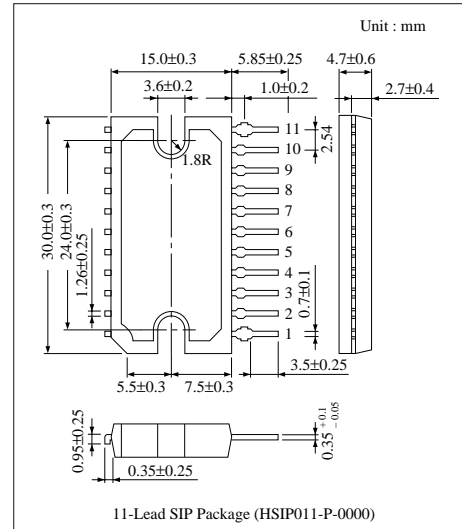

■ Block Diagram

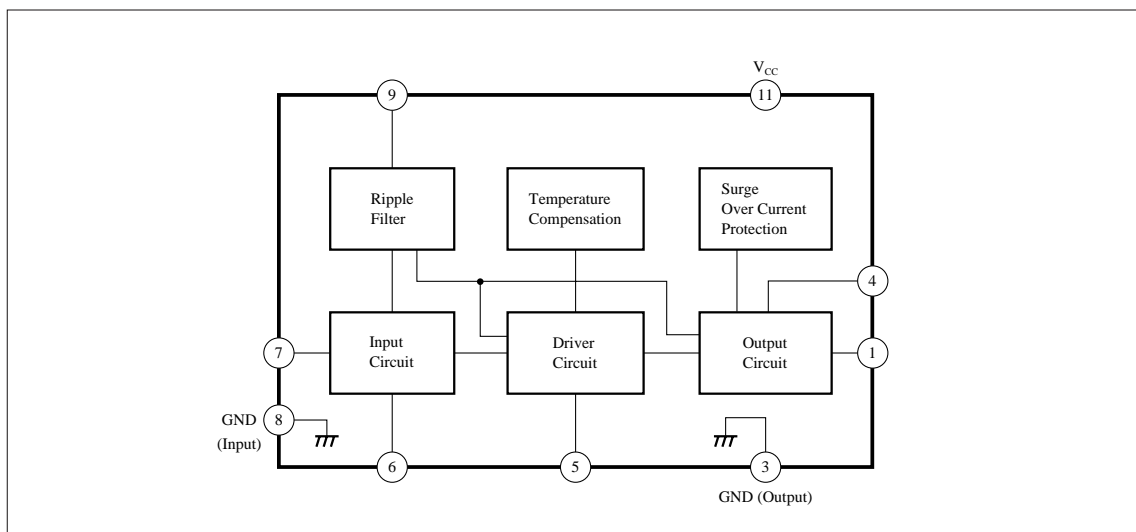

■ Absolute Maximum Ratings (Ta= 25°C)

Parameter	Symbol	Rating	Unit
Supply Voltage (at no signal)	V _{CC}	35	V
Supply Voltage (at operation)	V _{CC}	30	V
Peak Supply Voltage ^{Note 1)}	V _{CC(surge)}	60	V
Supply Current	I _{CC}	4	A
Power Dissipation ^{Note 2)}	P _D	31.25	W
Operating Ambient Temperature	T _{opr}	- 30 ~ + 75	°C
Storage Temperature	T _{stg}	- 55 ~ + 150	°C

Note 1) Pulse Voltage application t = 0.2s

Note 2) Ta = 25°C (θ_{j-c} = 4°C/W)

■ Electrical Characteristics (V_{CC}= 26.4V, f = 1kHz, Ta= 25°C)

Parameter	Symbol	Condition	min.	typ.	max.	Unit
(R_L= 8Ω)						
Quiescent Circuit Current	I _{CQ}	V _i = 0mV	40	75	160	mA
Voltage Gain	G _V	V _i = 3mV	51	53	55	dB
No Distortion Maximum Output	P _O	THD= 1%	8	9.5	—	W
		THD= 10%	10.5	12	—	W
Total Harmonic Distortion	THD	V _i = 3mV	—	0.1	0.7	%
Output Noise Voltage	V _{no}	R _g = 10kΩ, DIN A Filter	—	0.7	1.5	mV
Ripple Rejection Ratio	RR	V _i = 0mV, R _g = 0Ω	—	40	—	dB
Input Impedance	Z _i		—	30	—	kΩ
(R_L= 4Ω)						
No Distortion Maximum Output	P _O	THD= 1%	—	13	—	W
		THD= 10%	—	18	—	W

■ Pin Descriptions

Pin No.	Pin Name	Pin No.	Pin Name
1	Output	7	Input
2	NC	8	GND (Input)
3	GND (Output)	9	Ripple Filter
4	Bootstrap	10	NC
5	Phase Compensation	11	V _{CC}
6	Negative Feedback	—	—

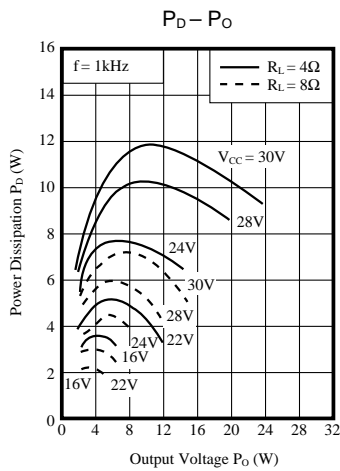
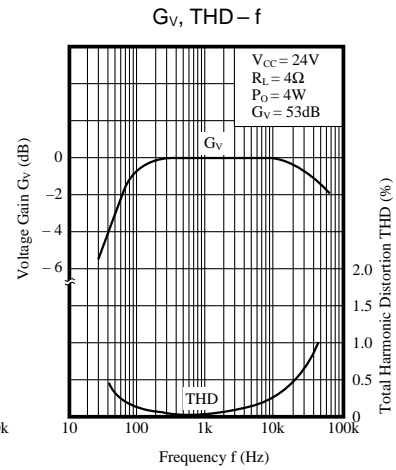
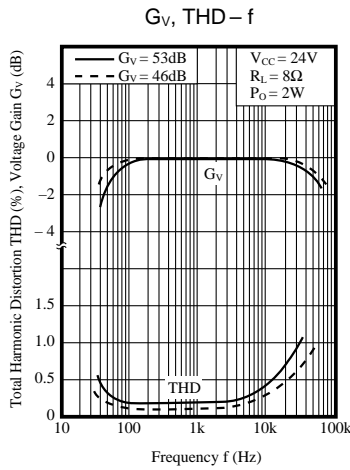
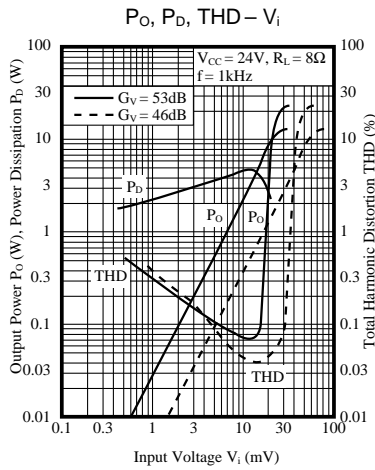
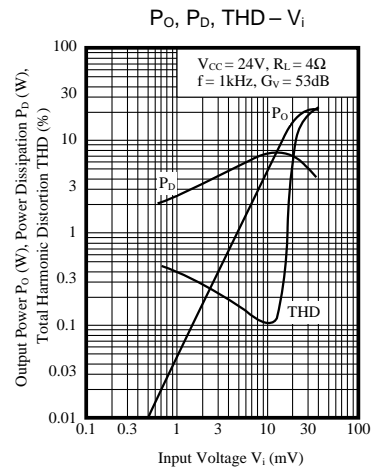
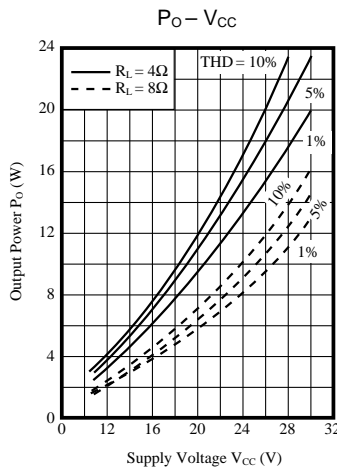
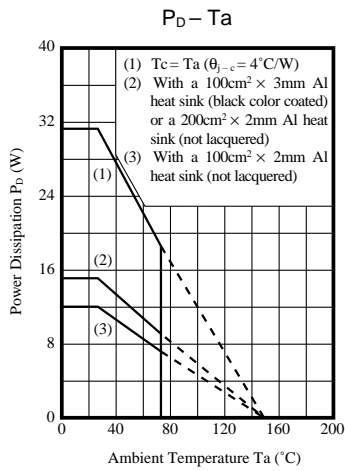

■ Application Circuit

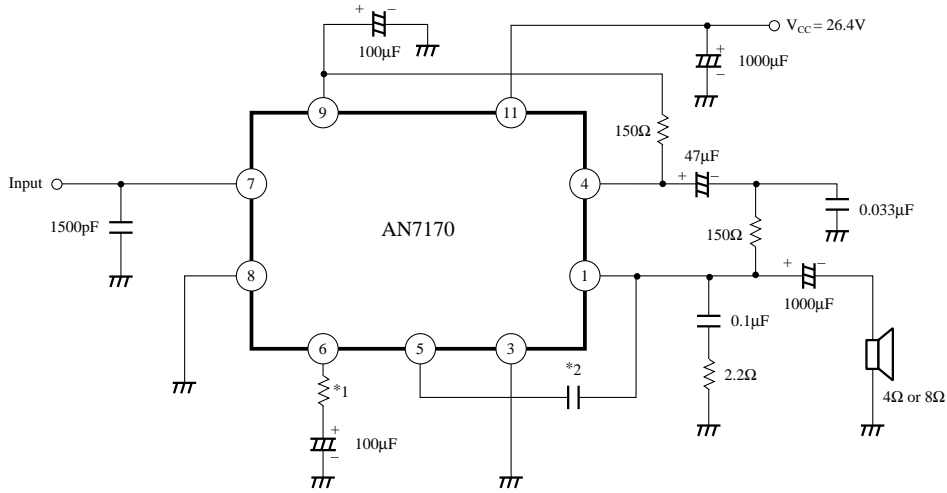

- *1. 82Ω at $G_V = 46\text{dB}$, $R = 0$ at $G_V = 53\text{dB}$
- *2. 12pF at $G_V = 46\text{dB}$, 8pF at $G_V = 53\text{dB}$
($C = 0$ is allowable for frequency characteristics adjustment in high band)

■ Printed Circuit Board Layout

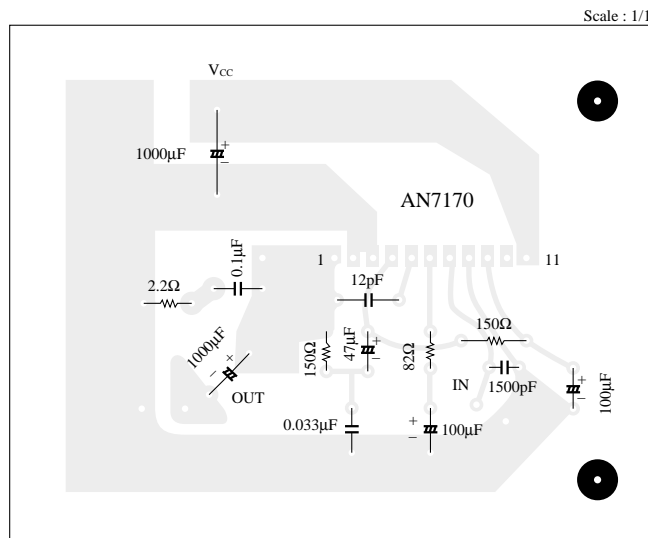



LittleDiode supplies new, hard to find or obsolete electronic components and semiconductors all over the world.

With over two million different components listed you are sure to find the part you need.

Feel free to visit us today at our online store:

LittleDiode.com

Looking forward to providing you with the best possible service.