

DS8641 Quad Unified Bus Transceiver

General Description

The DS8641 is a quad high speed drivers/receivers designed for use in bus organized data transmission systems interconnected by terminated 120Ω impedance lines. The external termination is intended to be a 180Ω resistor from the bus to the +5V logic supply together with a 390Ω resistor from the bus to ground. The bus can be terminated at one or both ends. Low bus pin current allows up to 27 driver/receiver pairs to utilize a common bus. The bus loading is unchanged when $V_{CC} = 0V$. The receivers incorporate tight thresholds for better bus noise immunity. One two-input NOR gate is included to disable all drivers in a package simultaneously.

Features

- 4 separate driver/receiver pairs per package
- Guaranteed minimum bus noise immunity of 0.6V, 1.1V typ
- Temperature insensitive receiver thresholds track bus logic levels
- $30\mu A$ typical bus terminal current with normal $V_{CC} = 0V$ and with $V_{CC} = 0V$
- Open collector driver output allows wire-OR connection
- High speed
- Series 74 TTL compatible driver and disable inputs and receiver outputs

Connection Diagram

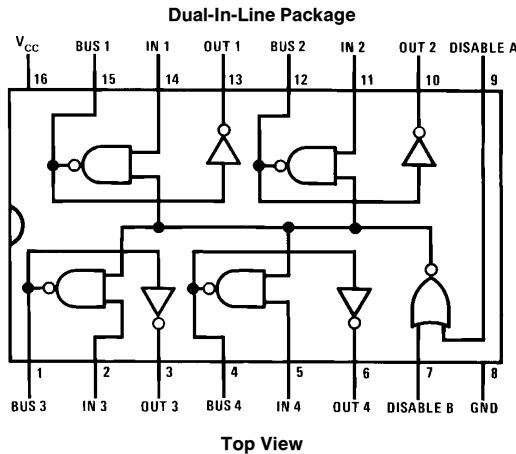

TL/F/5806-1

Order Number DS8641N
See NS Package Number N16A

Typical Application

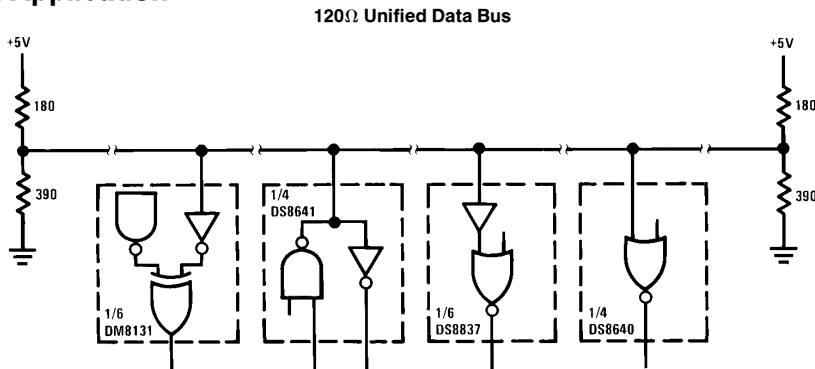

TL/F/5806-2

Absolute Maximum Ratings (Note 1)

If Military/Aerospace specified devices are required, please contact the National Semiconductor Sales Office/Distributors for availability and specifications.

Supply Voltage	7V
Input and Output Voltage	5.5V
Storage Temperature Range	-65°C to +150°C
Maximum Power Dissipation* at 25°C	
Cavity Package	1433 mW
Molded Package	1362 mW
Lead Temperature (Soldering, 4 seconds)	260°C

Operating Conditions

	Min	Max	Units
Supply Voltage, (V _{CC}) DS8641	4.75	5.25	V
Temperature Range, (T _A) DS8641	0	+70	°C

*Derate molded package 10.9 mW/°C above 25°C.

Electrical Characteristics

The following apply for V_{MIN} ≤ V_{CC} ≤ V_{MAX}, T_{MIN} ≤ T_A ≤ T_{MAX} unless otherwise specified (Notes 2 and 3)

Symbol	Parameter	Conditions	Min	Typ	Max	Units
DRIVER AND DISABLE INPUTS						
V _{IH}	Logical "1" Input Voltage		2.0			V
V _{IL}	Logical "0" Input Voltage				0.8	V
I _I	Logical "1" Input Current	V _{IN} = 5.5V			1	mA
I _{IH}	Logical "1" Input Current	V _{IN} = 2.4V			40	μA
I _{IL}	Logical "0" Input Current	V _{IN} = 0.4V			-1.6	mA
V _{CL}	Input Diode Clamp Voltage	I _{DIS} = -12 mA, I _{IN} = -12 mA, I _{BUS} = -12 mA, T _A = 25°C		-1	-1.5	V
DRIVER OUTPUT/RECEIVER INPUT						
V _{OLB}	Low Level Bus Voltage	V _{DIS} = 0.8V, V _{IN} = 2V, I _{BUS} = 50 mA		0.4	0.7	V
I _{IHB}	Maximum Bus Current	V _{IN} = 0.8V, V _{BUS} = 4V, V _{CC} = V _{MAX}		30	100	μA
I _{ILB}	Maximum Bus Current	V _{IN} = 0.8V, V _{BUS} = 4V, V _{CC} = 0V		2	100	μA
V _{IH}	High Level Receiver Threshold	V _{IND} = 0.8V, V _{OL} = 16 mA	1.70	1.50		V
V _{IL}	Low Level Receiver Threshold	V _{IND} = 0.8V, V _{OH} = -400 μA		1.50	1.30	V
RECEIVER OUTPUT						
V _{OH}	Logical "1" Output Voltage	V _{IN} = 0.8V, V _{BUS} = 0.5V, I _{OH} = -400 μA	2.4			V
V _{OL}	Logical "0" Output Voltage	V _{IN} = 0.8V, V _{BUS} = 4V, I _{OL} = 16 mA		0.25	0.4	V
I _{OS}	Output Short Circuit Current	V _{DIS} = 0.8V, V _{IN} = 0.8V, V _{BUS} = 0.5V, V _{OS} = 0V, V _{CC} = V _{MAX} , (Note 4)	-18		-55	mA
I _{CC}	Supply Current	V _{DIS} = 0V, V _{IN} = 2V, (per Package)		50	70	mA

Switching Characteristics $T_A = 25^\circ\text{C}$, $V_{CC} = 5\text{V}$, unless otherwise indicated

Symbol	Parameter	Conditions	Min	Typ	Max	Units
t_{PD}	Propagation Delays (Note 7)	(Note 5)				
	Disable to Bus "1"			19	30	ns
	Disable to Bus "0"			15	30	ns
	Driver Input to Bus "1"			17	25	ns
	Driver Input to Bus "0"		17	25	ns	
	Bus to Logical "1" Receiver Output	(Note 6)		20	30	ns
Bus to Logical "0" Receiver Output			18	30	ns	

Note 1: "Absolute Maximum Ratings" are those values beyond which the safety of the device cannot be guaranteed. They are not meant to imply that the devices should be operated at these limits. The table of "Electrical Characteristics" provides conditions for actual device operation.

Note 2: Unless otherwise specified min/max limits apply across the 0°C to $+70^\circ\text{C}$ range for the DS8641. All typical values are for $T_A = 25^\circ\text{C}$ and $V_{CC} = 5\text{V}$.

Note 3: All currents into device pins shown as positive, out of device pins as negative, all voltages referenced to ground unless otherwise noted. All values shown as max or min on absolute value basis.

Note 4: Only one output at a time should be shorted.

Note 5: 91Ω from bus pin to V_{CC} and 200Ω from bus pin to ground. $C_{LOAD} = 15\text{ pF}$ total. Measured from $V_{IN} = 1.5\text{V}$ to $V_{BUS} = 1.5\text{V}$, $V_{IN} = 0\text{V}$ to 3V pulse.

Note 6: Fan-out of 10 load, $C_{LOAD} = 15\text{ pF}$ total. Measured from $V_{IN} = 1.5\text{V}$ to $V_{OUT} = 1.5\text{V}$, $V_{IN} = 0\text{V}$ to 3V pulse.

Note 7: The following apply for $V_{CC} = 5\text{V}$, $T_A = 25^\circ\text{C}$ unless otherwise specified.

Physical Dimensions inches (millimeters) (Continued)

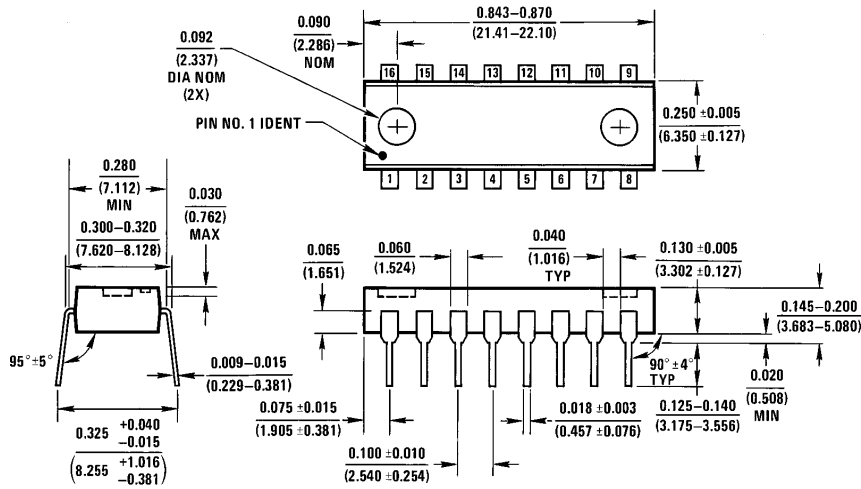

Molded Dual-In-Line Package (N)
Order Number DS8641N
NS Package Number N16A

N16A (REV E)

LIFE SUPPORT POLICY

NATIONAL'S PRODUCTS ARE NOT AUTHORIZED FOR USE AS CRITICAL COMPONENTS IN LIFE SUPPORT DEVICES OR SYSTEMS WITHOUT THE EXPRESS WRITTEN APPROVAL OF THE PRESIDENT OF NATIONAL SEMICONDUCTOR CORPORATION. As used herein:

1. Life support devices or systems are devices or systems which, (a) are intended for surgical implant into the body, or (b) support or sustain life, and whose failure to perform, when properly used in accordance with instructions for use provided in the labeling, can be reasonably expected to result in a significant injury to the user.
2. A critical component is any component of a life support device or system whose failure to perform can be reasonably expected to cause the failure of the life support device or system, or to affect its safety or effectiveness.



National Semiconductor Corporation
 1111 West Bardin Road
 Arlington, TX 76017
 Tel: 1(800) 272-9959
 Fax: 1(800) 737-7018

<http://www.national.com>

National Semiconductor Europe

Fax: +49 (0) 180-530 85 86
 Email: europe.support@nsc.com
 Deutsch Tel: +49 (0) 180-530 85 85
 English Tel: +49 (0) 180-532 78 32
 Français Tel: +49 (0) 180-532 93 58
 Italiano Tel: +49 (0) 180-534 16 80

National Semiconductor Hong Kong Ltd.

19th Floor, Straight Block,
 Ocean Centre, 5 Canton Rd.
 Tsimshatsui, Kowloon
 Hong Kong
 Tel: (852) 2737-1600
 Fax: (852) 2736-9960

National Semiconductor Japan Ltd.

Tel: 81-043-299-2308
 Fax: 81-043-299-2408

National does not assume any responsibility for use of any circuitry described, no circuit patent licenses are implied and National reserves the right at any time without notice to change said circuitry and specifications.

National Semiconductor was acquired by Texas Instruments.

http://www.ti.com/corp/docs/investor_relations/pr_09_23_2011_national_semiconductor.html

This file is the datasheet for the following electronic components:

DS8641 - <http://www.ti.com/product/ds8641?HQS=TI-null-null-dscatalog-df-pf-null-ww>



LittleDiode supplies new, hard to find or obsolete electronic components and semiconductors all over the world.

With over two million different components listed you are sure to find the part you need.

Feel free to visit us today at our online store:

LittleDiode.com

Looking forward to providing you with the best possible service.