

HA1394

Dual 6 to 8W Audio Power Amplifier

The HA1394 dual audio power amplifier is specifically designed for audio outputs in modular stereos and multiplex sound TV's. This amplifier can deliver 8.2W/channel when $V_{CC}=25V$, $R_L=8\Omega$ and THD=5%.

FEATURES

- Dual power amplifier; 7~8.2W per channel
- Low external components count (Capacitor: 11, Resistor: 6 per 2 channel)
- Wide supply voltage range: from 18 to 35V
- Low noise and low distortion
- Internal thermal protection.

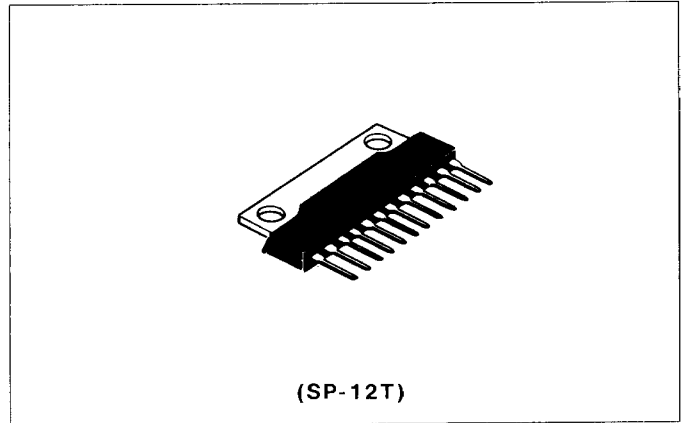

TYPICAL APPLICATION

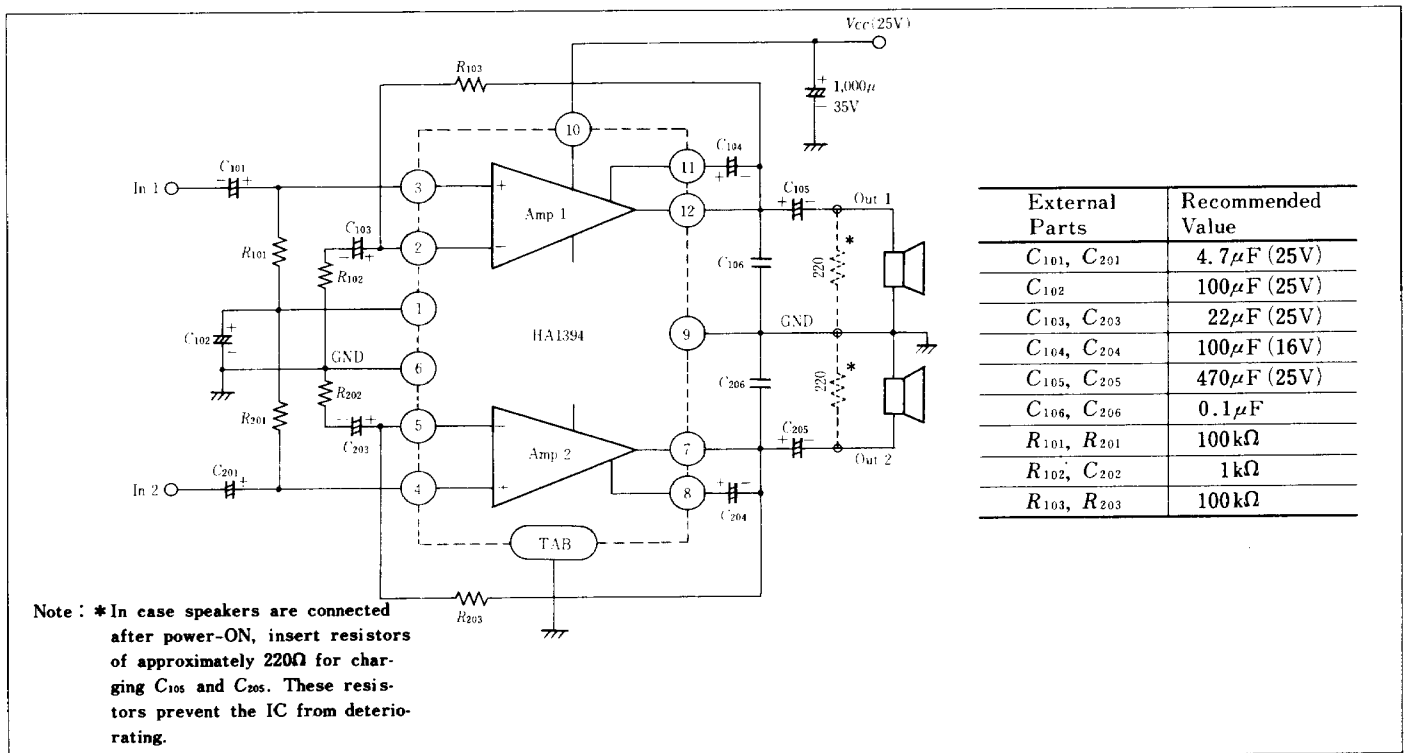

ABSOLUTE MAXIMUM RATINGS ($T_a=25^\circ C$)

Item	Symbol	Rating	Unit
Supply Voltage	V_{CC}	35	V
Output Current per channel	$I_{O(peak)}$	4.5	A
Power Dissipation *	P_T	15	W
Junction Temperature	T_j	150	°C
Operating Temperature	T_{opr}	-20 to +70	°C
Storage Temperature	T_{stg}	-55 to +125	°C

* Value at $T_c=90^\circ C$ (T_c : Temperature of IC Header)



■ ELECTRICAL CHARACTERISTICS ($V_{CC}=25V$, $R_L=8\Omega$, $T_a=25^\circ C$, 2-channel operation)

Item	Symbol	Test Condition	min	typ	max	Unit	
Quiescent Current	I_Q	$V_{in}=0$ (2-channel)	—	80	150	mA	
Voltage Gain	G_V	$f=1kHz$	—	40	—	dB	
Difference of Voltage Gain	ΔG_V	$f=1kHz$	—	—	1.5	dB	
Output Power per Channel	P_{out}	$R_L=8\Omega$, $THD=5\%$	7.0	8.2	—	W	
Total Harmonic Distortion	THD	$P_{out}=1W$, $f=1kHz$	—	0.04	0.8	%	
Noise Output	WBN	$R_s=10k\Omega$, $BW=20Hz$ to $20kHz$	—	0.22	1.0	mV	
Input Resistance	R_{in}	$f=1kHz$	—	100	—	k Ω	
Cross-Talk	$C.T$	$f=1kHz$, $R_s=600\Omega$	50	62	—	dB	
Supply Voltage Rejection Ratio	SVR	$f=100Hz$, $R_s=600\Omega$	45	57	—	dB	
Roll-off Frequency	f_L	$\Delta G_V=-3dB$ from $f=1kHz$ Ref.	Low	—	40	—	Hz
	f_H		High	—	80	—	kHz

■ PC-BOARD LAYOUT PATTERN

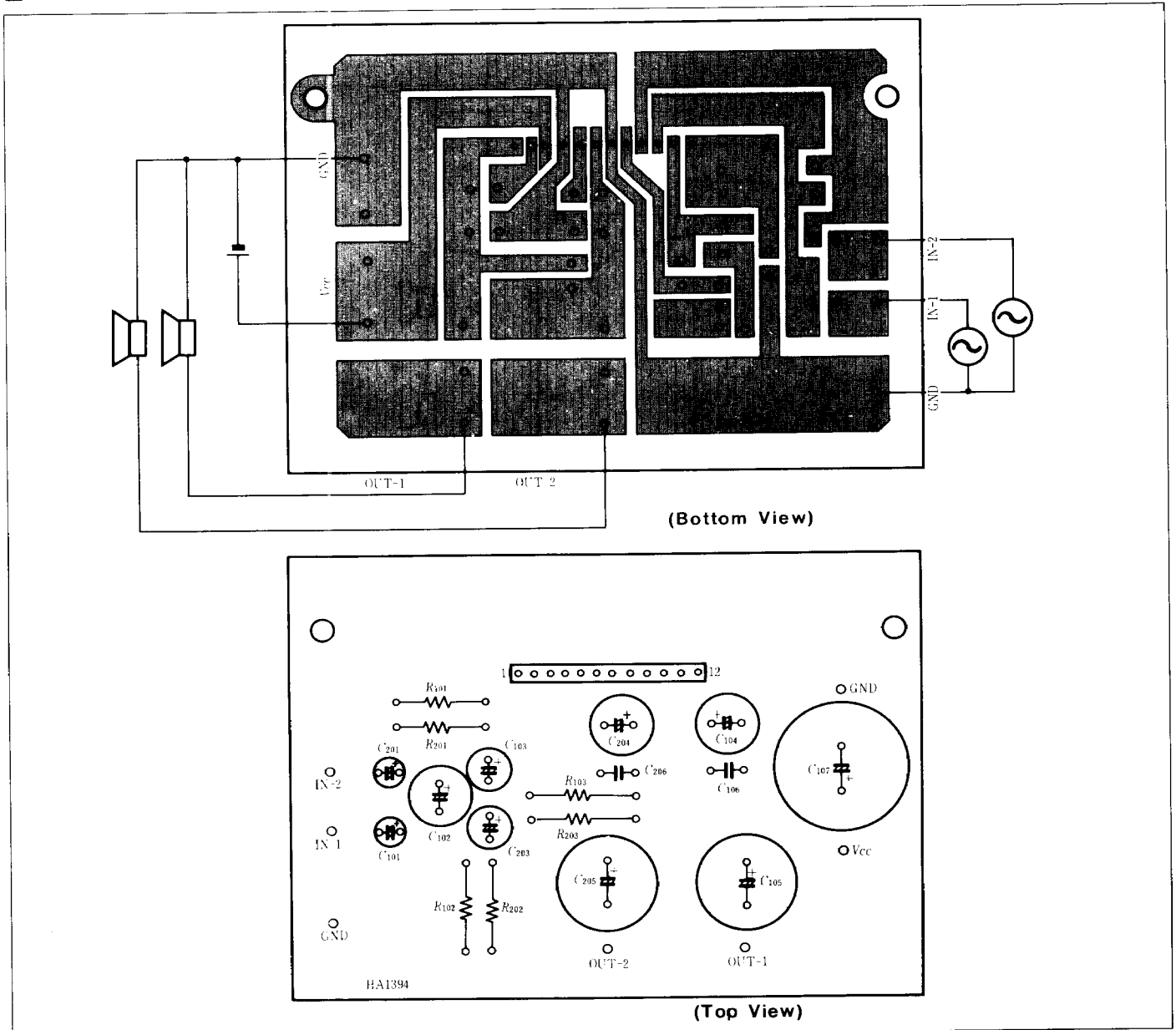

■ HEAT SINK

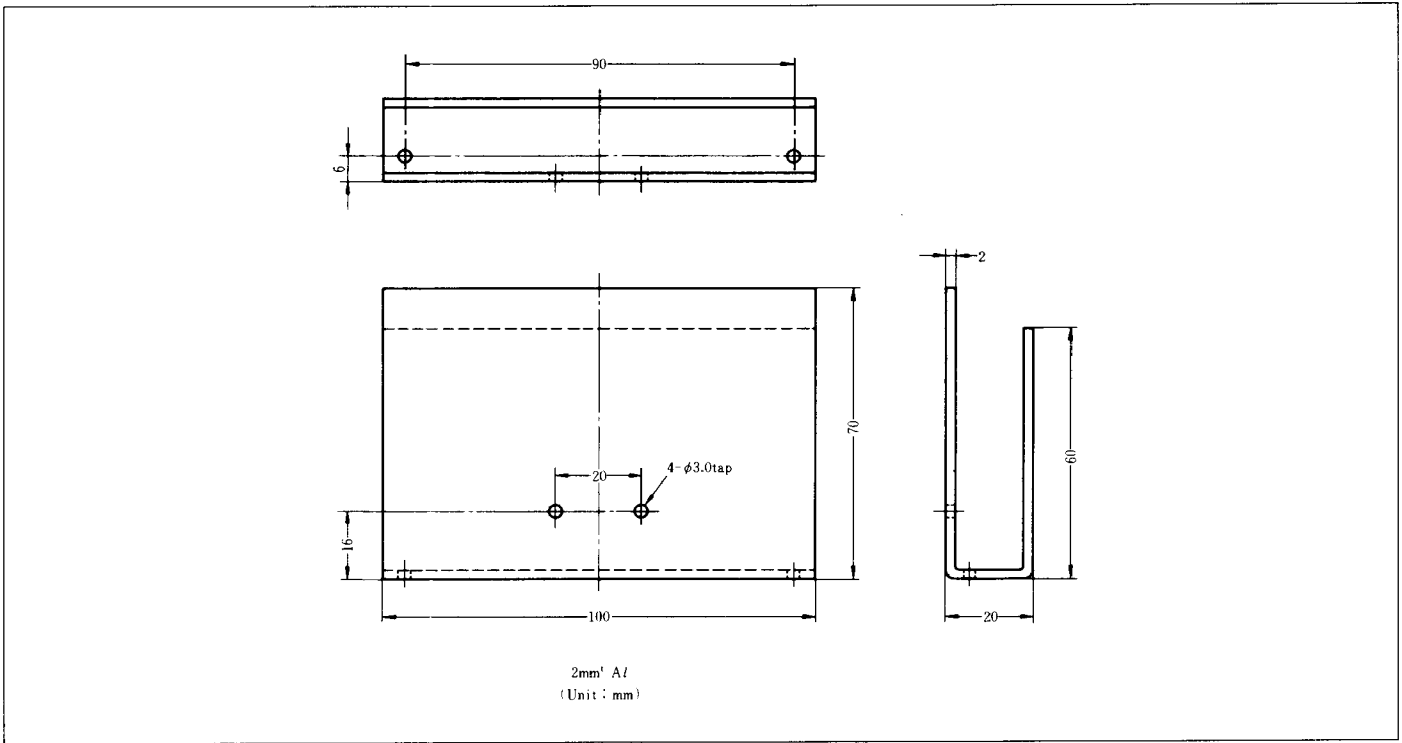

■ EXTERNAL COMPONENTS

Parts No.	Recommended Value	Purpose	Influence	
			Smaller than recommended value	Larger than recommended value
C ₁₀₁ C ₂₀₁	4.7μF (25V)	Input coupling	Increase of signal source resistance; Higher 1/f noise	—
C ₁₀₂	100μF (25V)	Supply voltage ripple rejection	Deterioration of supply voltage ripple rejection	More time required for some sound supply after power-ON
C ₁₀₃ C ₂₀₃	22μF (25V)	Feedback	Higher low frequency roll-off	Pop sound at switch-on
C ₁₀₄ C ₂₀₄	100μF (16V)	Bootstrap	Narrower power bandwidth	—
C ₁₀₅ C ₂₀₅	470μF (25V)	Output coupling	Higher low frequency roll-off	Values larger than 1000μF may cause IC deterioration
C ₁₀₆ C ₂₀₆	0.1μF	Frequency Stability	Causes oscillation	Increase current consumption at high frequency
R ₁₀₁ R ₂₀₁	100kΩ	DC bias for input pins 3 and 4; Determination of input resistance	Smaller input resistance	—
R ₁₀₂ R ₂₀₂	1kΩ	Determination of voltage gain*	—	—
R ₁₀₃ R ₂₀₃	100kΩ		Deviation of pins 7 and 12 voltages from the V _{CC} /2 (R ₁₀₃ /R ₂₀₃ values should be the same as R ₁₀₁ /R ₂₀₁ .)	

Note : * $G_v = 20 \log \left(\frac{R_{102} + R_{103}}{R_{102}} \right)$ (dB)



OUTPUT POWER VS. SUPPLY VOLTAGE (1)

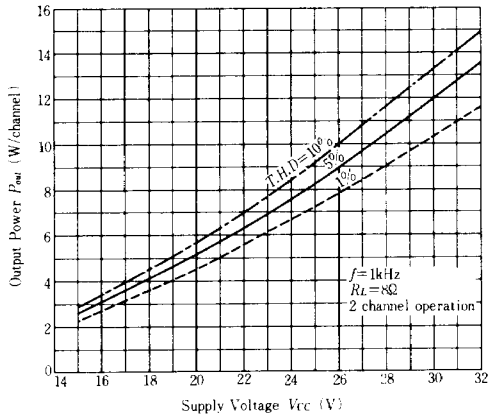

OUTPUT POWER VS. SUPPLY VOLTAGE (2)

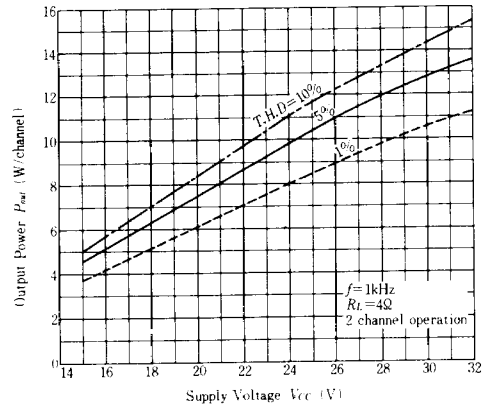

OUTPUT POWER VS. FREQUENCY

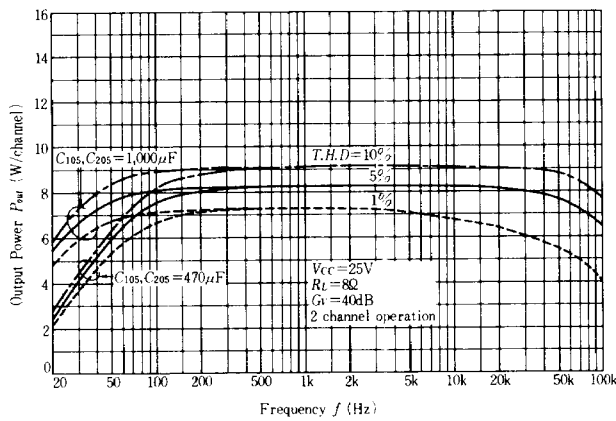

TOTAL HARMONIC DISTORTION VS. OUTPUT POWER

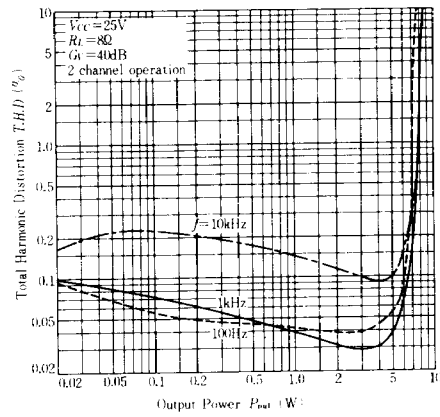

TOTAL HARMONIC DISTORTION VS. FREQUENCY

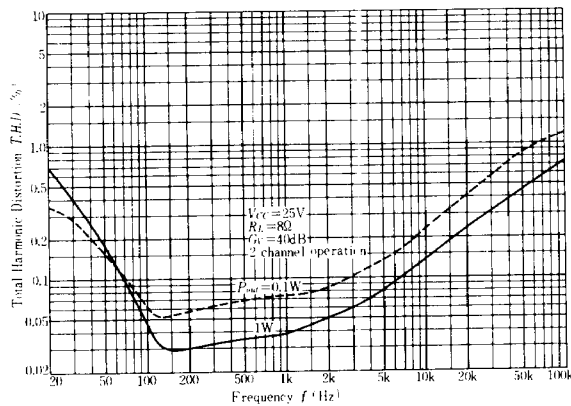

CROSS-TALK VS. FREQUENCY

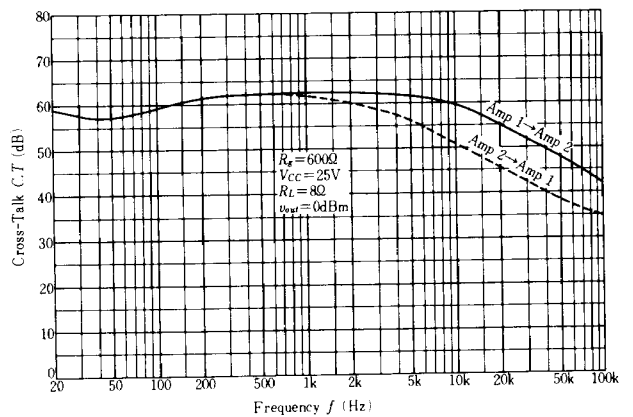

SUPPLY VOLTAGE REJECTION RATIO VS. RIPPLE FREQUENCY

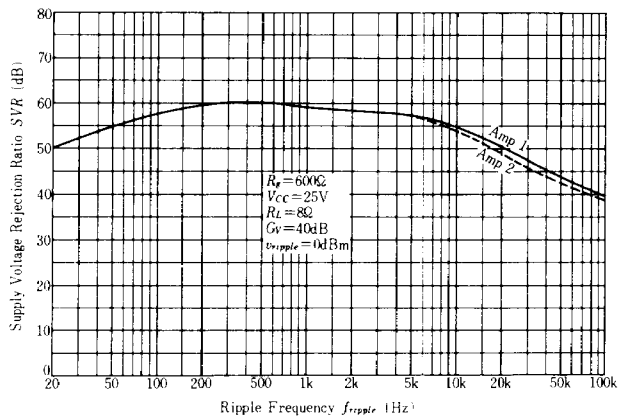

OUTPUT NOISE VOLTAGE VS. SIGNAL SOURCE RESISTANCE

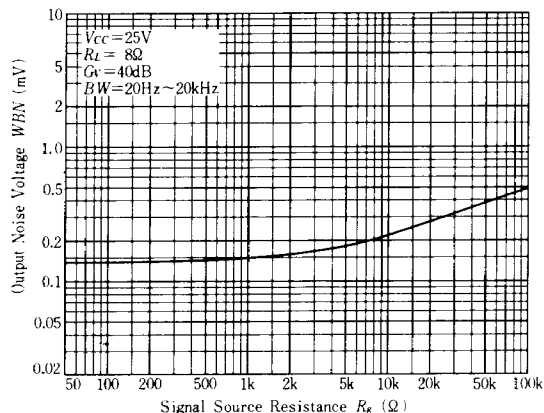

CROSS-TALK VS. SIGNAL SOURCE RESISTANCE

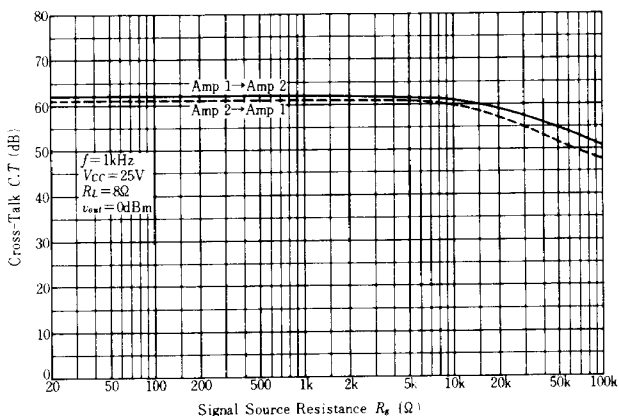

SUPPLY VOLTAGE REJECTION RATIO VS. SIGNAL SOURCE RESISTANCE

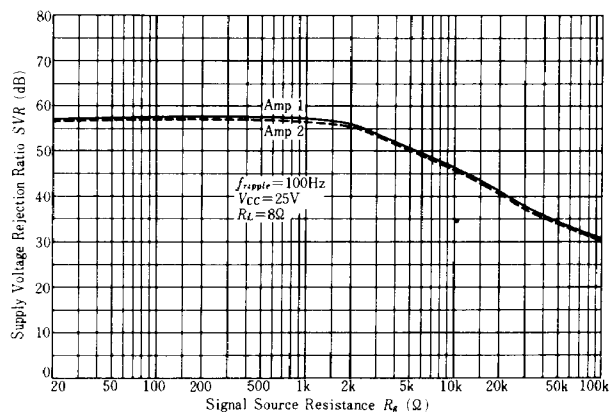

POWER DISSIPATION VS. OUTPUT POWER

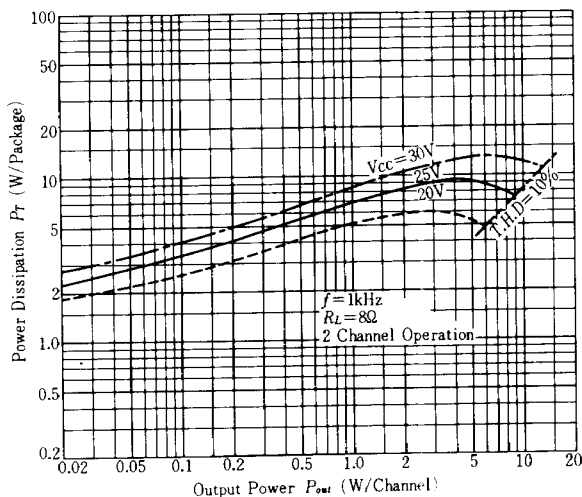

QUIESCENT CURRENT VS. SUPPLY VOLTAGE

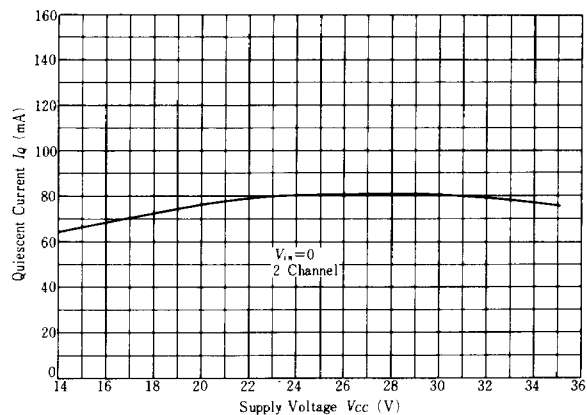

■CIRCUIT EXAMPLE – NF Tone Control

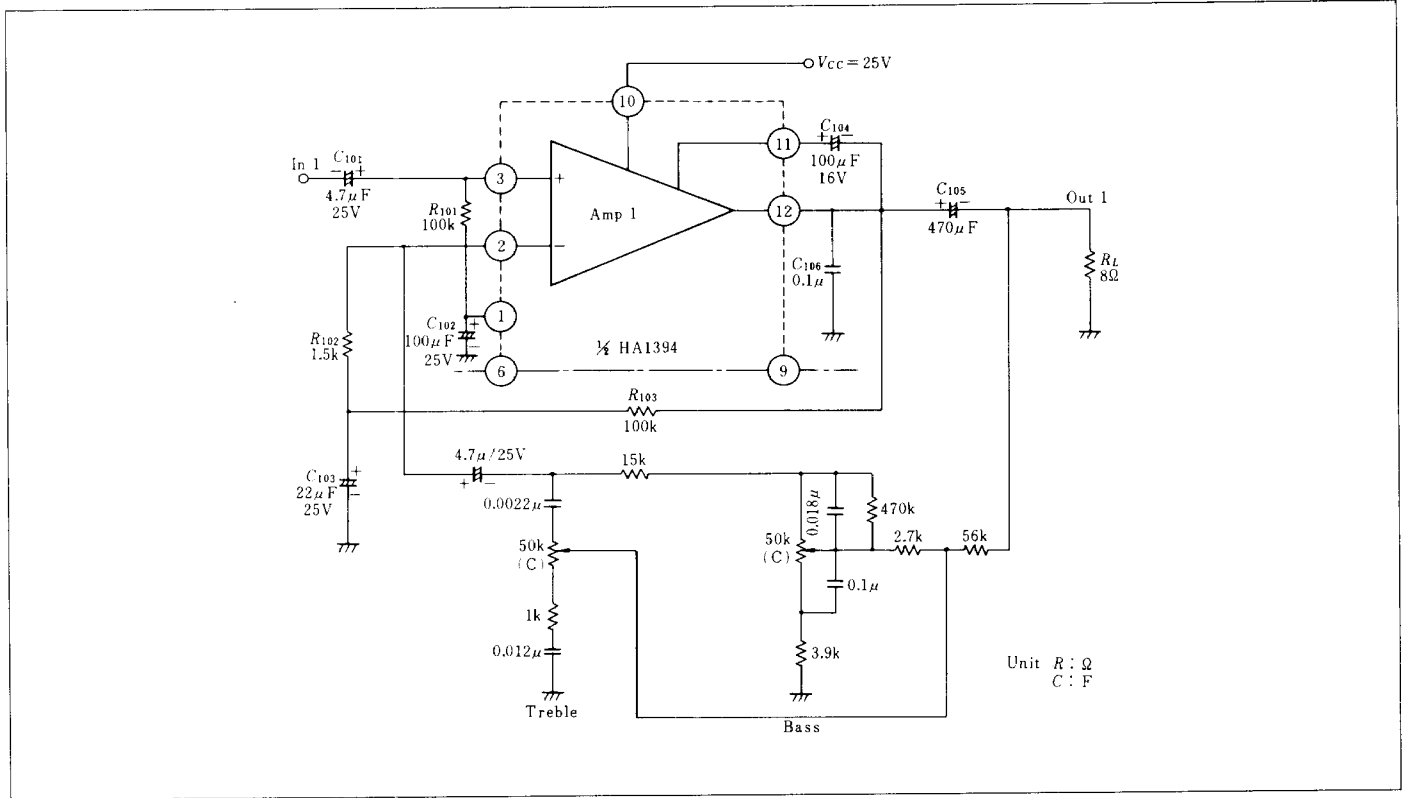

VOLTAGE GAIN VS. FREQUENCY

